



PRONAR SP. Z O.O.

17-210 NAREW, UL. MICKIEWICZA 101A, WOJ. PODLASKIE

PHONE: +48 085 681 63 29

+48 085 681 64 29

+48 085 681 63 81

+48 085 681 63 82

FAX: +48 085 681 63 83

+48 085 682 71 10

www.pronar.pl

OPERATOR MANUAL

TRAILED SWEEPER

PRONAR ZMC3.1

TRANSLATION OF THE ORIGINAL COPY OF THE MANUAL

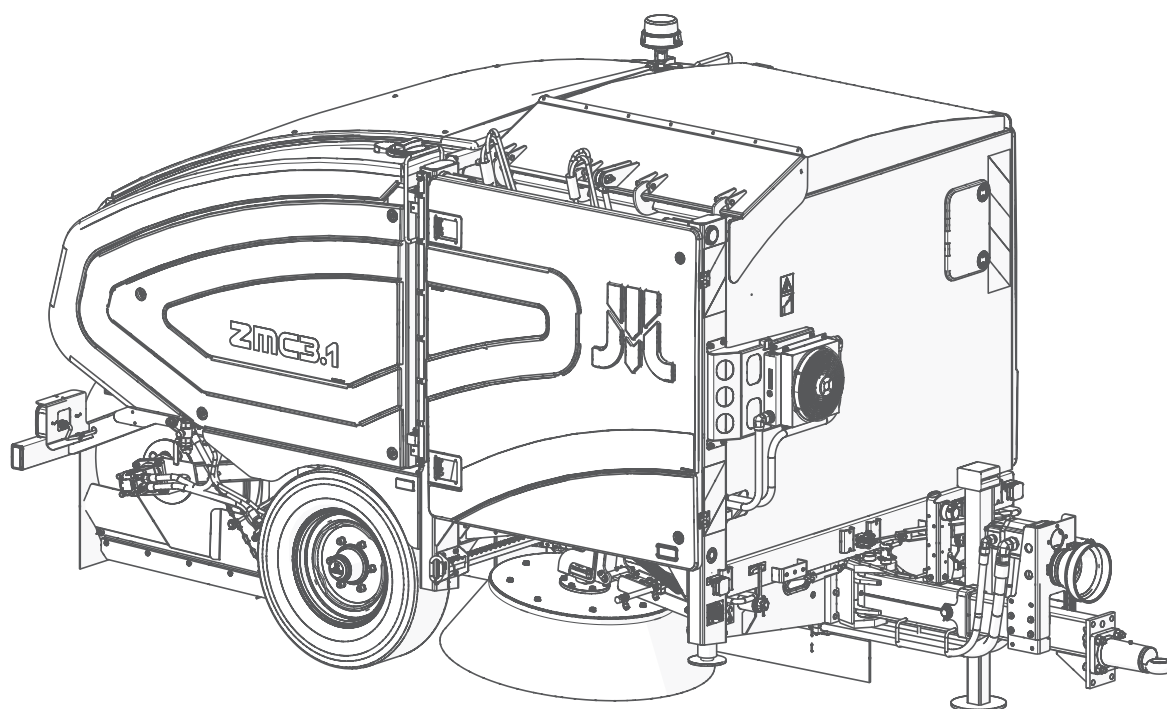

REVISION 2A

04-2020

PUBLICATION NO.: 588.01.UM



TABLE OF CONTENTS

INTRODUCTION

INTRODUCTION	2
SYMBOLS APPEARING IN THIS OPERATOR MANUAL	3
DIRECTIONS USED IN THIS OPERATOR MANUAL	4
INSPECT THE MACHINE UPON DELIVERY	5
FIRST START-UP OF THE MACHINE	6

BASIC INFORMATION

1.1 IDENTIFICATION	1.2
1.2 INTENDED USE	1.4
1.3 REQUIREMENTS	1.5
1.4 EQUIPMENT	1.6
1.5 TERMS & CONDITIONS OF WARRANTY	1.7
1.6 TRANSPORT	1.8
1.7 ENVIRONMENTAL RISK	1.11
1.8 WITHDRAWAL FROM USE	1.12

SAFETY ADVICE

2.1 BASIC SAFETY RULES	2.2
2.2 SAFETY WHEN HITCHING THE MACHINE	2.3
2.3 MACHINE OPERATION	2.4
2.4 TRANSPORTING THE MACHINE	2.5
2.5 SAFETY RULES WHEN MAINTAINING HYDRAULIC SYSTEM AND PNEUMATIC SYSTEM	2.6
2.6 SAFE MAINTENANCE PRINCIPLES	2.7
2.7 DRIVING ON PUBLIC ROADS	2.9
2.8 TYRES	2.11
2.9 OPERATING PTO SHAFT.	2.12
2.10 DESCRIPTION OF RESIDUAL RISK	2.14
2.11 INFORMATION AND WARNING DECALS	2.16

DESIGN AND OPERATION

3.1 TECHNICAL SPECIFICATION	3.2
3.2 HYDRAULIC SYSTEM	3.3
3.3 SWEEP SYSTEM	3.6
3.4 SPRAY SYSTEM	3.7
3.5 CONVEYOR AND WASTE CONTAINER	3.8
3.6 BRAKE SYSTEM	3.9
3.7 ELECTRICAL SYSTEM	3.12

CONTROL PANEL

4.1 CONTROL PANEL	4.2
4.2 LCD PANEL	4.4
4.3 LCD PANEL MENU	4.5

CORRECT USE

5.1	PREPARE FOR WORK	5.2
5.2	TECHNICAL INSPECTION	5.4
5.3	CONNECT THE MACHINE TO THE CARRIER VEHICLE (TRACTOR)	5.6
5.4	SWEEPER OPERATION	5.14
5.5	DRIVING ON PUBLIC ROADS	5.29
5.6	STOP THE MACHINE - EMERGENCY MODE	5.31
5.7	AUDIBLE ALARM	5.32
5.8	UNHITCH THE MACHINE FROM THE CARRIER VEHICLE	5.33

MAINTENANCE

6.1	SERVICE INTERLOCK	6.2
6.2	ADJUST THE SWEEPING UNIT AND CONVEYOR	6.3
6.3	REPLACE BRUSHES AND CONVEYOR COMPONENTS	6.7
6.4	HYDRAULIC SYSTEM MAINTENANCE	6.10
6.5	MULTIPLIER GEAR BOX MAINTENANCE	6.15
6.6	SPRAY SYSTEM SERVICE	6.16
6.7	ELECTRICAL SYSTEM MAINTENANCE	6.18
6.8	BRAKE ADJUSTMENT	6.19
6.9	PNEUMATIC SYSTEM MAINTENANCE	6.21
6.10	CHECK AND ADJUST WHEEL AXLE BEARINGS	6.24
6.11	WHEEL MAINTENANCE	6.25
6.12	LUBRICATION	6.27
6.13	CENTRAL LUBRICATION (OPTION)	6.33
6.14	STORAGE	6.34
6.15	TIGHTEN BOLT CONNECTIONS	6.35
6.16	TROUBLESHOOTING	6.36



PRONAR Sp. z o.o.

ul. Mickiewicza 101 A
17-210 Narew, Polska

tel./fax (+48 85) 681 63 29, 681 63 81, 681 63 82,
681 63 84, 681 64 29

fax (+48 85) 681 63 83

http://www.pronar.pl

e-mail: pronar@pronar.pl

CE DECLARATION OF CONFORMITY OF THE MACHINERY

PRONAR Sp. z o.o. declares with full responsibility, that the machine:

Description and identification of the machinery	
Generic denomination and function:	Trailed sweeper
Type:	ZMC3.1
Model:	—
Serial number:	
Commercial name:	Trailed sweeper PRONAR ZMC3.1

to which this declaration relates, fulfills all the relevant provisions of the Directive **2006/42/EC** of The European Parliament and of The Council of 17 May 2006 on machinery, and amending Directive 95/16/EC (Official Journal of the EU, L 157/24 of 09.06.2006).

The person authorized to compile the technical file is the Head of Research and Development Department at PRONAR Sp. z o.o., 17-210 Narew, ul. Mickiewicza 101A, Poland.

This declaration relates exclusively to the machinery in the state in which it was placed on the market, and excludes components which are added and/or operations carried out subsequently by the final user.

Narew, the 2020-07-27

Place and date

PRONAR Spółka z o.o.
17-210 Narew ul. Mickiewicza 101A
Tel. (85) 681 63 29, 682 72 54
Fax: (85) 681 63 83
NIP 543-02-00-939, KRS 0000139188
BDO 000014169

Z-CIA DYREKTORA
d/s technicznych
członek zarządu

Roman Świątek

Full name of the empowered person
position, signature

INTRODUCTION

INTRODUCTION

Information in this document is current at date of publication. As a result of improvements, some numerical values and illustrations contained in this publication may not correspond to the actual specification of the machine supplied to the user. The manufacturer reserves the right to introduce design changes in machines produced that facilitate and improve the quality of machine operation, without making minor amendments to this Operator Manual.

This Operator Manual is an integral part of the machine documentation. Before using the machine, the user must carefully read

this Operator Manual and observe all recommendations. This guarantees safe operation and ensures failure-free work of the machine. The machine is designed to meet obligatory standards, documents and legal regulations currently in force.

If the information in this Operator Manual needs clarification, refer for assistance to the sale point where the machine was purchased or to the Manufacturer.

It is recommended that the serial number of the machine is inscribed in the spaces below after purchase of the machine.

This Operator Manual contains important safety and operating instructions for the machine. The Operator Manual should be kept near the machine so that it is accessible to authorized operators.

Keep this manual for future reference. If the Operator Manual is lost or damaged, contact the seller or the manufacturer for a copy.

The Operator Manual is intended for the end user. For this reason, some required maintenance activities are listed in the inspection tables but the procedure is not described in this Operator Manual. To perform these activities, call the manufacturer's authorized service centre.

U.10.1.EN

SYMBOLS APPEARING IN THIS OPERATOR MANUAL

DANGER

Information, descriptions of danger and precautions as well as recommendations and prohibitions associated with the safety of use are marked in the text with the sign **DANGER**. Failure to observe the instructions may endanger the machine operator's or other person's health or life.

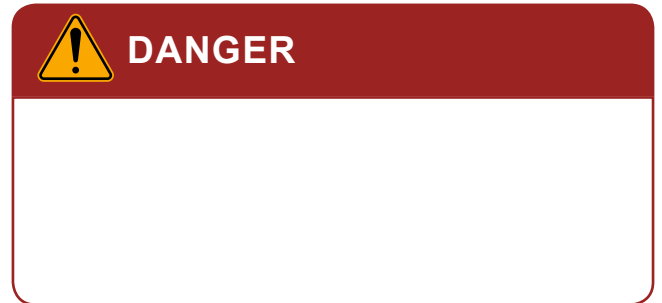

IMPORTANT

Vital information and instructions that must be observed are highlighted by a border and accompanied by the text: **IMPORTANT**. Failure to observe the instructions may lead to damage to the machine as a result of improper operation, adjustment or use.

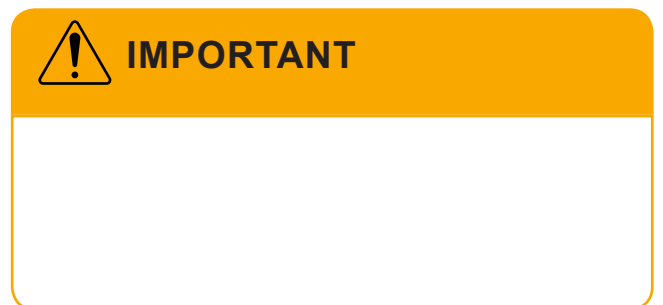

TIP

Additional tips included in the Operator Manual describe useful advice for the machine operation and are marked with the sign **TIP**.



U.02.1.EN

DIRECTIONS USED IN THIS OPERATOR MANUAL

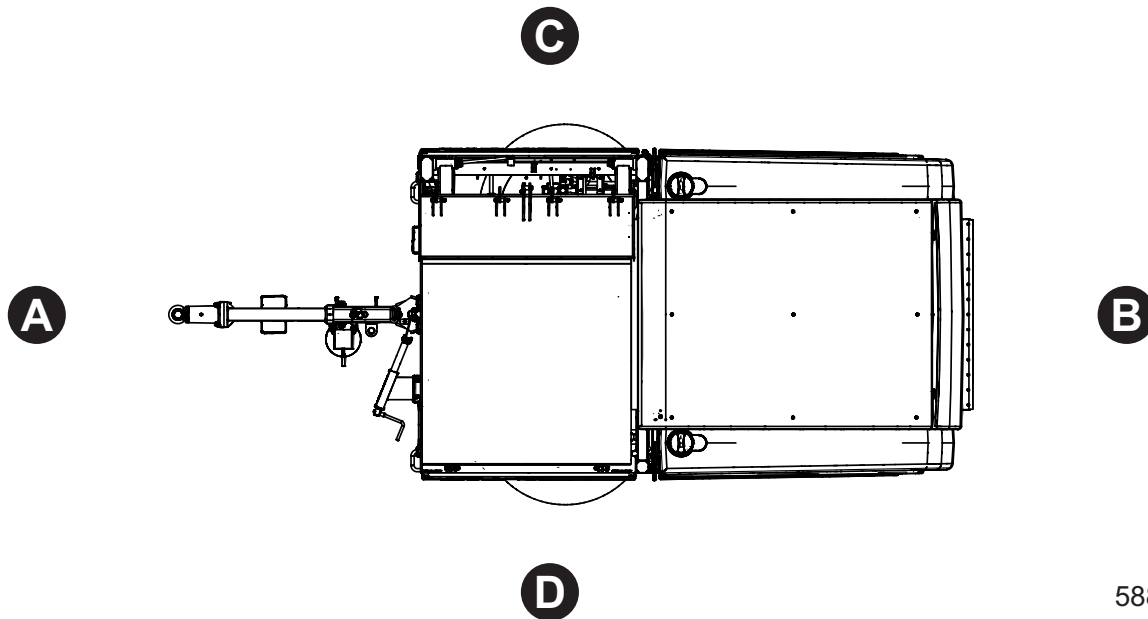

588-U.01-1

Rysunek 1.1 Directions used with reference to the machine

(A) front (B) rear (C) right side (D) left side

Left side – side to the left hand of the operator facing in the direction of machine's forward travel.

Right side – side to the right hand of the operator facing in the direction of machine's forward travel.

Rotation to the right – clockwise rotation of a mechanism (the operator is facing the mechanism).

Rotation to the left – counterclockwise rotation of a mechanism (the operator is facing the mechanism).

U.03.1.EN

INSPECT THE MACHINE UPON DELIVERY

The manufacturer guarantees that the machine is fully operational and has been checked according to quality control procedures and is ready for use. This does not release the user from an obligation to check the machine's condition after delivery and before first use. The machine is delivered to the user completely assembled. Detailed information concerning the machine hand-over are included in the WARRANTY BOOK.

INSPECTION RECOMMENDATIONS

- Check completeness of the machine according to order (standard and optional equipment).
- Check the machine for missing parts or damage resulting from wrong transport of the machine to its destination (crushing, piercing, bending or breaking of parts etc.).
- Check technical condition of covers and protection devices.
- Check condition of paint coating; check the machine for traces of corrosion.
- Check technical condition of tyres and tyre pressure.

TIP

Releasing the machine to the buyer involves a detailed visual inspection and verification of the machine operation, as well as instructions for the buyer on the basic principles of operation.

The trailer is operated for the first time in the presence of the Seller.

- Check if the nuts and bolts fixing the wheels are properly tightened.
- Check technical condition of drawbar eye and if correctly installed.
- Check technical condition of elastic hydraulic lines.
- Check technical condition of pneumatic conduits.
- Check that there are no hydraulic oil leaks.
- Check the electric lamps of the machine.
- Check electrical controls (panel, harness).
- Check hydraulic cylinders for leaks of hydraulic oil.

Discovered defects should be notified directly to the seller in order to remove them.

U.11.2.EN

FIRST START-UP OF THE MACHINE



IMPORTANT

During the first use, the machine is checked in the presence of the Seller. The Seller is obliged to conduct the training in safe and correct operation of the trailer.

Training by the seller does not release the user from the obligation to read this manual in advance and follow the instructions in it.



IMPORTANT

After the first 3 hours of machine operation, check and, if necessary, adjust the tension of the conveyor belts according to the section „ADJUSTING THE SWEEPING UNIT AND CONVEYOR”

Before you start using the machine, you should familiarize yourself with its design, principle of operation, available equipment and operation and, above all, with safety rules.

PROCEDURE

- The user must read this Operator Manual and observe all the recommendations contained in it.
- Adjust the height of the drawbar to the tractor hitch.
- Perform the daily inspection of the machine in accordance with the guidelines in the inspection schedule.
- Check all the machine lubrication points, lubricate if necessary according to the recommendations in the lubrication schedule.
- Check correct tightening of bolt and nut connections (in particular connections of suspension system, drawbar eye and wheels).
- Ensure that pneumatic, hydraulic and

electric connections in agricultural tractor are according to the requirements, if not the machine should not be hitched to the carrier vehicle.

If all the above checks have been performed and there is no doubt as to the good technical condition of the machine, it can be connected to tractor.

Start tractor, inspect individual systems and conduct test start-up of machine and make test drive without loading. It is recommended that the inspection is conducted by two people, one of which should always remain in the tractor cab. Test start should be conducted according to the sequence shown below.

- Connect the machine to the appropriate hitch on the agricultural tractor.
- Connect the brake system and electrical system lines (see „5.3 HITTING TO TRACTOR”).
- Turn on individual lights, check the operation of the electrical system.
- Connect the PTO shaft to the tractor

Power take-off shaft.

- Start and check the operation of the hydraulic system and all functions of the machine (see „5.4 SWEEPER OPERATION“).
- When moving off check if the main brakes operate correctly.
- Perform test drive. Check the machine's braking efficiency while driving.
- Stop tractor and turn off the engine, immobilise the tractor and the machine with parking brake.

If during test run worrying symptoms occur such as:

- excessive noise and abnormal sounds originating from the rubbing of moving elements,
- leakage and pressure drop in braking system,



DANGER

Careless and incorrect use and operation of the machine, and failure to follow instructions in this Operator Manual is dangerous to your life and health. The machine must never be used by unauthorised persons, including children, and people under the influence of alcohol or other abusive substances. Non-compliance with the safety rules of this Operator's Manual can be dangerous to the health and life of the operator and others.

- incorrect operation of hydraulic and / or pneumatic cylinders,
- other faults,

stop operating the trailer and do not operate it until the malfunction is corrected. If a fault cannot be rectified or the repair could void the warranty, please contact retailer for additional clarifications or to perform the repair.

After completion of test drive check tightness of wheel nuts.

2.6.588.02.1.EN

SECTION 1

BASIC INFORMATION

1.1 IDENTIFICATION

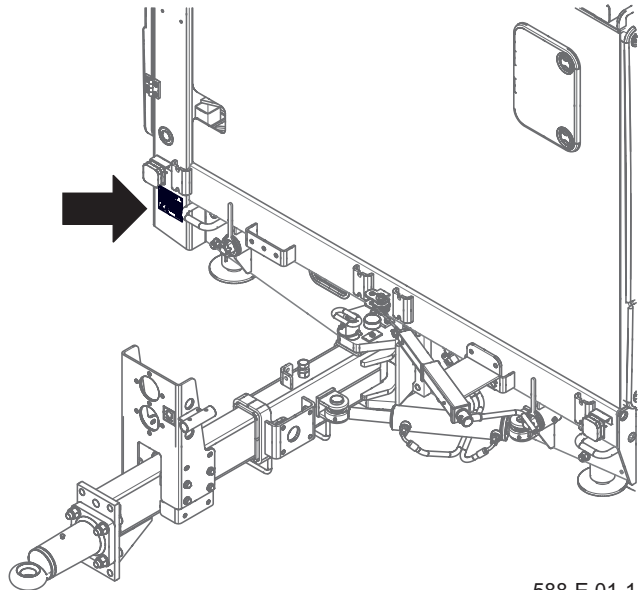
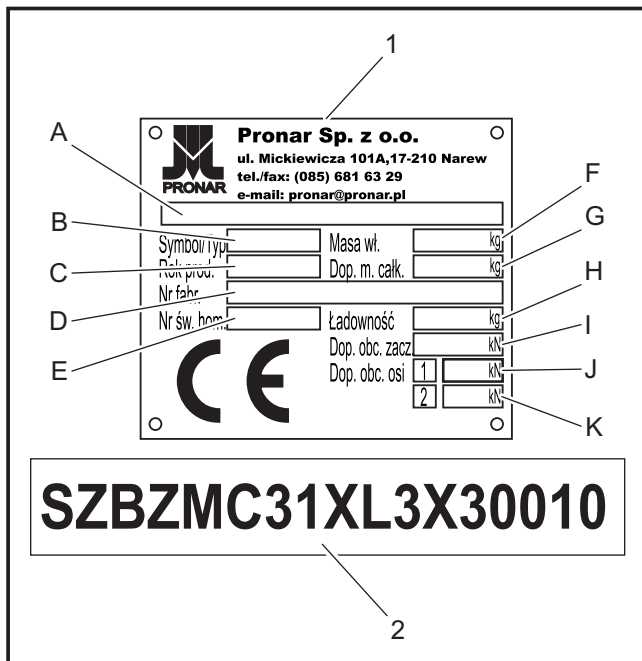

588-E.01-1

Figure 1.1 Machine identification

(1) nameplate

(2) the VIN of the machine



Table 1.1. Markings on nameplate

The machine is marked with a nameplate (1) on the right-hand front wall beam and a serial number (2) is stamped under the nameplate. The meaning of the individual items found on the nameplate are presented in table (1.1). Record the serial number in the upper box.

LP.	Meaning
A	General description and purpose
B	Symbol /Machine type
C	Year of manufacture
D	VIN
E	Official certificate number
F	Tare weight
G	Maximum gross weight
H	Carrying capacity
I	Permissible hitching system load
J	Permissible axle 1 load
K	Permissible second axle load - not applicable

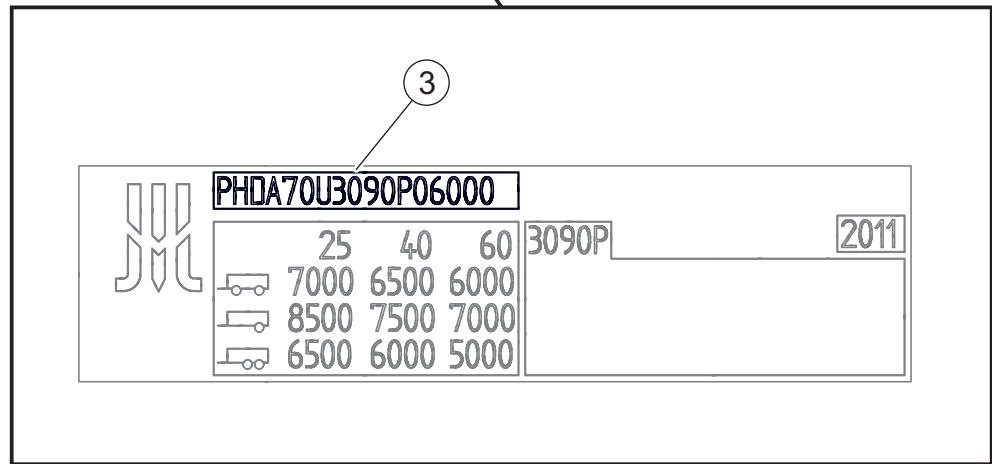
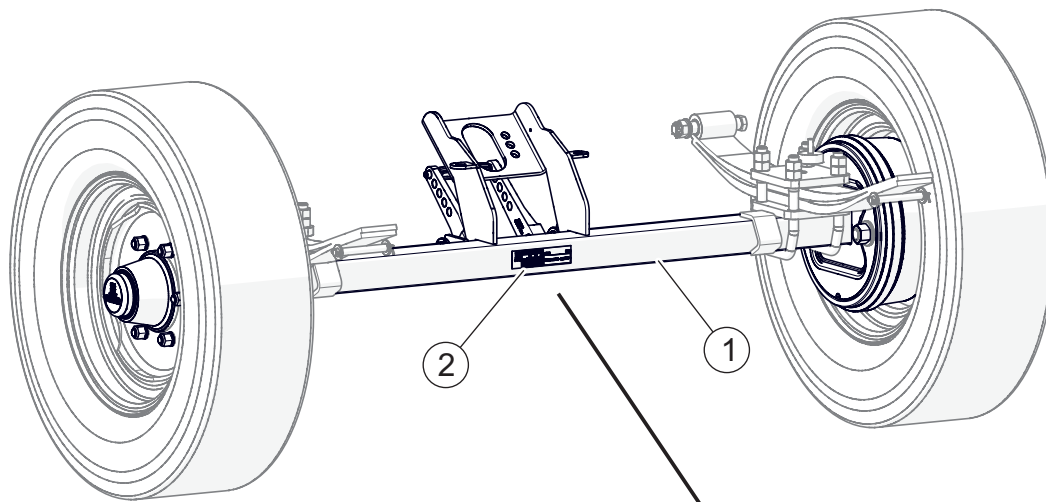

588-E.02-1

Figure 1.2 Axle identification
 (1) wheel axle (2) name plate (3) axle serial number

The serial number of the axle and its type are stamped onto the nameplate secured to the axle profile – figure (1.2).

After purchasing the machine, it is recommended to enter the serial number of the axle in the box below.

--	--	--	--	--	--	--	--	--	--	--	--	--	--	--	--	--	--	--	--

E.2.6.588.01.1.EN

1.2 INTENDED USE

PRONAR ZMC3.1 sweeper is used for sweeping hard-surfaced streets (cobblestone, asphalt, concrete) and large areas such as yards, parking spaces, warehouse areas. The side brush also allows you to sweep gutters, sewer bays and paved strips behind the curb. Using the machine for other purposes will be regarded as contrary to intended use.

The sweeper is designed for operation with agricultural tractors and other carrier vehicles that meet the requirements presented in Table 1.2.

Using it as intended also involves all actions connected with the safe and proper operation and maintenance of the machine. Due to the above, the user is obliged to:

- carefully read the *Operator Manual* and the *Warranty Book* and follow instructions in these documents,
- understand the machine operating principle and how to operate it safely and correctly,
- adhere to the established maintenance and adjustment plans,
- comply with general safety regulations while working,
- prevent accidents,



DANGER

The machine must not be used for purposes other than those for which it is intended, in particular for transporting people and animals.



IMPORTANT

The transport speed of the machine must not exceed the maximum design speed of 40 km/h (20 km/h if there is no official approval).

- comply with the road traffic regulations and transport regulations in force in the given country, in which the machine is used,
- carefully read the carrier vehicle's Operator Manual and comply with its recommendations.
- only hitch the machine to an agricultural tractor which meets all the Manufacturer's requirements.

The machine may only be used by persons, who:

- are familiar with the contents of this publication and with the contents of the carrying vehicle Operator Manual,
- have been trained in the machine operation and work safety,
- have the required authorisation to drive and are familiar with the road traffic regulations and transport regulations.

E.2.6.588.02.1.EN

1.3 REQUIREMENTS

Table 1.2. Carrier vehicle requirement

Contents	Unit	Requirements
Brake system connection sockets		
Double line pneumatic system	-	according to ISO 1728
Single line pneumatic system	-	according to ISO 1728
Hydraulic system	-	according to ISO 72411
Nominal pressure of the brake system*		
pneumatic,	bar	6
Hydraulic system	bar	160
Electrical system		
Electrical system voltage	V	12
Connection socket	-	7-pole, ISO 1724
Tractor hitches		
Minimum vertical load capacity of hitch	kg	1,700
Lower transport hitch*	-	non-rotating, fork type, Piton Fix or hook, located under the PTO shaft
– drawbar eye diameter	mm	50
- hitch height from the ground	mm	285 - 505
Upper transport hitch*	-	rotary , located above the PTO shaft
– drawbar eye diameter	mm	40
- hitch height from the ground	mm	745 - 1,055
power take-off shaft		
Type	-	Type 1 according to ISO 500 Ø35 mm, 6 splines
Rotation speed	rpm	540
Rotation direction	-	right, looking at the face of the PTO shaft
Other requirements		
Minimum power demand for the tractor PTO	kW / hp	35/47.5

* -depending on the machine assembly version

1.4 EQUIPMENT

The sweeper equipment includes:

- Operator Manual
- Warranty Book
- control panel
- 7-pole connection lead.

Additional (optional) equipment:

- vibrator system (facilitates waste container emptying),
- working lights (illuminate the operating zone of the side brushes),
- warning lights (additional 2 flashing light at the rear),
- spraying beam (to be mounted on the tractor front three-point linkage),
- hydraulic tilt of the left brush (controlled from the operator's cabin),
- right side brush (additional brush pulled out on the right side),

- washer (lance with cable and winding drum),
- electric nozzle switching (for conveyor and left brush),
- spray nozzle pressure control system (controlled from operator panel),
- extension of the chute (extends the chute by 200 mm),
- wheel chocks,
- step (additional, on the left side),
- water gauge (additional, on the left side),
- PTO shaft (6 splines, working range $L = 710-1180$ mm measured from the cross to the cross, $M = 540$ Nm),
- spare wheel 235/75R17.5 (not mounted on the machine),
- license plate bracket (with lighting).

E.2.6.588.04.1.EN

1.5 TERMS & CONDITIONS OF WARRANTY

PRONAR Sp. z o.o. Narew guarantees the reliable operation of the machine when it is used according to its intended purpose as described in the *Operator Manual*. The repair period is specified in the *Warranty Book*.

The warranty does not cover those parts and sub-assemblies of the machine which are subject to wear in normal usage conditions, regardless of the warranty period.

- slides , brushes, scrapers
- rubber shields
- filters , bearings
- bulbs , fuses, relays
- conveyor driving and idler wheels
- conveyor belts, etc.

The warranty service only applies to such cases as: mechanical damage which is not the user's fault, factory defects of parts, etc.

In the event of damage arising from:

- mechanical damage which is the user's fault, damage caused by road accidents;
- inappropriate use, adjustment or maintenance, use of the machine for purposes other than those for which it is intended;

TIP

Demand that the seller carefully and accurately fills out the Warranty Book and warranty repair coupons. A missing date of purchase or sale point stamp may make the user ineligible for any warranty repair or refund.

- use of damaged machine;
- repairs carried out by unauthorised persons, repairs carried out improperly;
- making unauthorised alterations to machine design;

the user will lose the right to warranty service.

The user is obliged to report immediately on noticing any wear in the paint coating or traces of corrosion, and to have the faults rectified whether they are covered by the warranty or not.

For detailed Terms & Conditions of Warranty, please refer to the *Warranty Book* attached to each newly purchased machine. Modification of the machine without the written consent of the Manufacturer is prohibited. In particular, do NOT weld, drill holes in, cut or heat the main structural elements of the machine which have a direct impact on the machine operation safety.

E.2.6.588.05.1.EN

1.6 TRANSPORT

The machine is prepared for sale completely assembled and does not require packing. Packing is only required for the machine's technical documentation, operator control panel and any extra accessories. The machine is delivered to the user either transported on a vehicle or independently (towed), after being attached to a tractor.

SHIPPING BY ROAD

Loading and unloading of the machine from vehicle shall be conducted using loading ramp with the aid of an agricultural tractor. During work, adhere to the general principles of occupational health and safety (OHS) applicable to reloading work. Persons operating reloading equipment must have the qualifications required to operate these machines. The machine must be properly hitched to the tractor according to the requirements specified in this Operator's Manual. The machine braking system must be started and checked before driving off or onto ramp.

The machine should be attached firmly to the platform of the vehicle using straps or chains fitted with a tightening mechanism. Securing elements should be attached to the transport catches designed for this purpose (FIGURE 1.3). The transport lugs



DANGER

When shipped by road on a motor vehicle the machine must be mounted on the vehicle's platform in accordance with the safety requirements and regulations.

Vehicle driver should be especially careful when driving. This is due to the vehicle's centre of gravity shifting upwards when the machine is loaded.

Use only certified and technically reliable securing measures. Carefully read the manufacturer's instructions for the securing measures.

are located on the frame. The machine has four attachment points to the load box. Side shield covers should be additionally secured against opening with belts wrapped around the machine.

Chocks or other objects without sharp edges should be placed under the machine wheels to prevent it from rolling. Wheel blocks must be secured to the load box of the vehicle in a manner preventing their movement.

Use certified and technically reliable securing measures. Worn straps, cracked securing catches, bent or corroded hooks as well as elements damaged in a different way may be unsuitable for use. Carefully read the information stated in the Operator Manual for the given securing measure. The number of securing elements (cables, straps, chains, stays etc.) and the force

necessary for their tensioning depend on a number of factors, including weight of the machine, carrying vehicle design, ground speed and other conditions. For this reason it is impossible to define the securing plan precisely.

To secure the machine optimally on the load box, support the drawbar with a wooden block. A correctly secured machine does not change its position with regard to the transporting vehicle. The securing elements must be selected according to the guidelines of the Manufacturer of these elements. In case of doubt apply a greater number of securing straps in order to secure the load. If necessary, cover the sharp edges of the machine in order to protect the securing elements from tearing or breaking during transport.

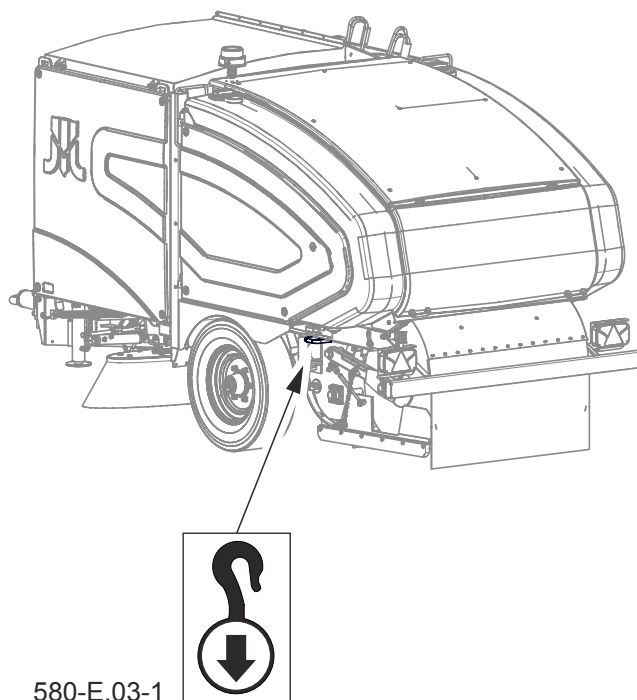

Figure 1.3 An attachment point for transport.



DANGER

Incorrect use of securing measures may cause an accident.



IMPORTANT

Do NOT secure lifting slings or any types of securing elements to hydraulic and electrical system components and fragile elements of the machine (e.g. shields, conduits)

During reloading work, take special care not to damage any accessories or paint finish.

TRAILER TRANSPORTED BY THE USER

In the event you independently transport the purchased machine, you must read the *Operator Manual* and adhere to its instructions. Independent transport involves towing the machine to destination with

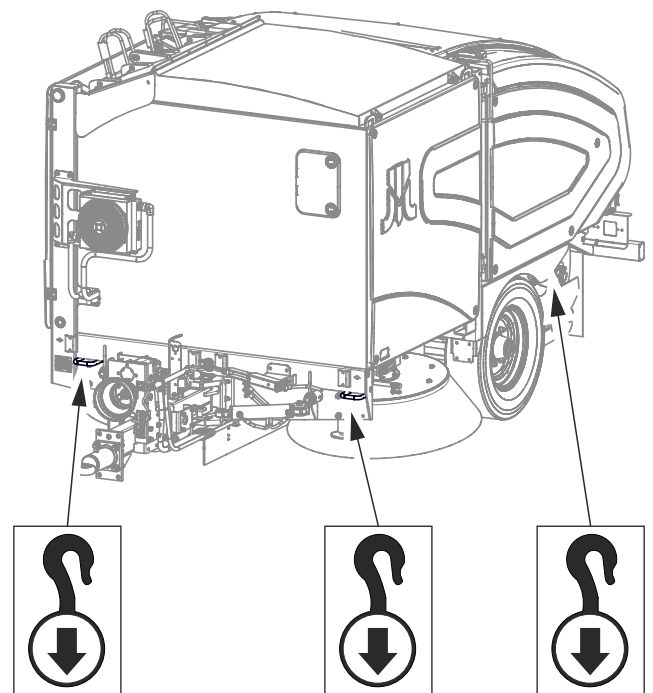

own towing vehicle such as an agricultural tractor. During transport adjust ground speed to the prevailing road conditions.

TIP

Depending on the version, centre of gravity varies in the ± 100 mm range.

**IMPORTANT**

The transport speed of the machine must not exceed the maximum design speed of 40 km/h (20 km/h if there is no official approval).

**DANGER**

When transporting independently, the user must carefully read this Operator Manual and observe all its instructions.

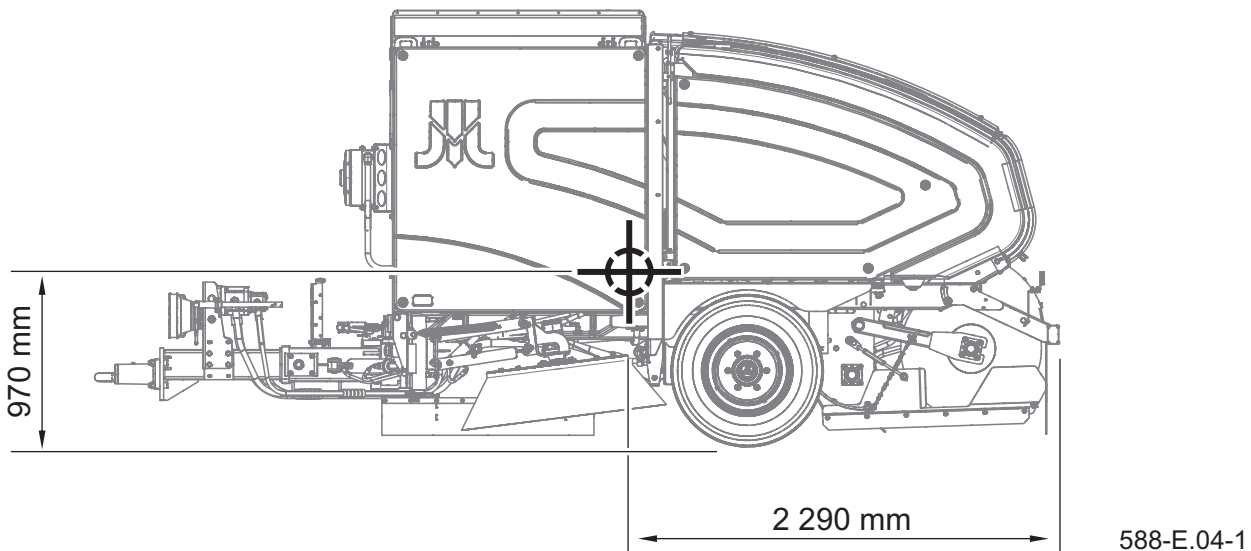

Figure 1.4 Centre of gravity
Machine with an empty water tank

E.2.6.588.06.1.EN

1.7 ENVIRONMENTAL RISK

A hydraulic oil leak constitutes a direct threat to the natural environment owing to its limited biodegradability. Maintenance and repair work which involves the risk of an oil leak should be performed in the rooms with oil resistant surface. In the event of oil leaking into the environment, first of all contain the source of the leak, and then collect the leaked oil using available means. Remaining oil should be collected using sorbents, or by mixing the oil with sand, sawdust or other absorbent materials. The oil contaminations, once gathered up, should be kept in a sealed, marked, hydrocarbon resistant container, and then passed on to the appropriate oil waste recycling centre. The container should be kept away from heat sources, flammable materials and food. Oil which has been used up or is unsuitable for further use owing to loss of its



IMPORTANT

Waste oil should only be taken to the appropriate facility dealing with the re-use of this type of waste. Do NOT dispose of or pour oil into sewerage drains or water reservoirs.



DANGER

Do not store oil waste in containers for food. Used oil should be stored in containers resistant to action of hydrocarbons.

TIP

The hydraulic system of the machine is filled with L-HL32 Lotos hydraulic oil.

properties should be stored in its original packaging in the conditions described above. Waste code: 13 01 10 (hydraulic oil). Detailed information on hydraulic oils can be found in the Material Safety Data Sheets.

E.3.4.622.08.1.EN

1.8 WITHDRAWAL FROM USE

Should you decide to withdraw the machine from use, comply with the regulations in force in the given country regarding withdrawal from use and recycling of machines withdrawn from use.

Before proceeding to dismantle machine, oil shall be completely removed from hydraulic system.

When spare parts are changed, worn out or damaged parts should be taken to a collection point for recyclable raw materials.



DANGER

During dismantling, use the appropriate tools, equipment (overhead crane, crane or hoist etc.) and use personal protection equipment, i.e. protective clothing, footwear, gloves and eye protection etc.

Avoid contact of skin with oil. Do not allow used hydraulic oil to spill.

Used oil and also rubber and plastic elements should be taken to the appropriate facilities dealing with the recycling of this type of waste.

E.3.4.622.09.1.EN

SECTION 2

SAFETY ADVICE

2.1 BASIC SAFETY RULES

- Before use, the user must carefully read this Operator Manual and the *Warranty Book*. When operating the machine, follow all instructions in these documents.
- The machine must never be used by persons who are not authorised to drive carrier vehicle, including children, and people under the influence of alcohol or other drugs.
- If the information in this Operator Manual is difficult to understand, contact the seller who runs the authorised technical service on behalf of the Manufacturer, or contact the Manufacturer directly.
- Careless and incorrect use and operation of the machine and also failure to follow the instructions of this Operator Manual may pose risk to the health and life of bystanders and/or machine operator.
- The user is obliged to learn about the design, operation and how to safely use the machine.
- The user is obliged to know the functions of all control elements of the machine. Do not start the machine without the knowledge of its functions.
- Be aware of the residual risk. Use caution when operating this machine and follow all relevant safety instructions.
- The machine must not be used for purposes other than those for which it is intended. Anyone who uses the machine other than the way intended takes full responsibility for himself for any consequences of this use. Use of the machine for purposes other than those for which it is intended by the Manufacturer may invalidate the guarantee.
- Before using the machine always check whether it is properly prepared for work, especially in terms of safety.

F.2.6.588.01.1.EN

2.2 SAFETY WHEN HITCHING THE MACHINE

- Do NOT hitch machine to tractor, if it does not meet the requirements of the Manufacturer (minimal tractor power demand, type of hitch, compatible connectors, etc) - see section *REQUIREMENTS*.
- Before hitching slurry tanker to tractor check that both machines are in good technical condition.
- While hitching the machine to the tractor, use the appropriate hitch. After completed hitching of the machines check that the hitch is properly secured. Carefully read the carrier vehicle Operator Manual. If the carrying vehicle is equipped with an automatic hitch, make certain that the coupling operation is completed.
- To hitch the machine to carrier vehicle use only genuine pins and safeguards.
- Be especially careful when hitching and unhitching the machine.
- When hitching, there must be nobody between the machine and the carrier vehicle.
- The machine must not be moved when the parking stand is extended and rests on the ground. If moved there is a risk of damage to the parking stand.
- Do not disconnect the sweeper from the tractor if the waste container is raised.
- The machine unhitched from carrier vehicle must be immobilised with parking brake. If the machine is positioned on a slope or elevation it should be additionally secured against moving by placing chocks under the machine's wheels.

F.2.6.588.02.1.EN

2.3 MACHINE OPERATION

- Before starting the carrier vehicle with connected machine make sure the PTO drive is not engaged, otherwise it can lead to uncontrolled operation of the machine.
- Each time the machine is used, always ensure that all the safety guards are closed, in good condition and in place.
- Before starting the machine, make sure that there are no bystanders (especially children) or animals in danger zone and inside the machine. The machine operator is obliged to ensure proper visibility of the machine and the working area.
- During machine operation do not occupy a different position than that of the operator in the tractor cab. Do NOT leave the cab, when the machine is in operation.
- Do NOT stand within the machine's working zone and also between the carrier vehicle and the machine when the carrier vehicle's engine is working.
- Do not approach rotating brushes.
- Empty the waste container on level, sufficiently hard ground, otherwise the machine may tip over.
- Before lifting the tank, make sure there are no bystanders near the machine.
- Waste container may be raised only when the machine is parked. Ensure that the stabilizing supports have been extended.
- Keep a safe distance from electric power lines while emptying the waste container.
- Do NOT leave the waste container in raised position if service interlocks are not installed.

F.2.6.588.03.1.EN

2.4 TRANSPORTING THE MACHINE

- Before driving on public roads, check operation of indicator lights.
- While driving on public roads the machine shall be marked with a warning triangle distinguishing slow-moving vehicles. The warning triangle should be attached to the rear of the machine.
- When driving on public roads, observe all road traffic regulations in force in the country, in which the machine is used.
- Do not exceed the maximum speed resulting from road conditions and design restrictions. Adjust speed to the prevailing road conditions and other limitations arising from road traffic regulations.
- Do not exceed maximum design speed.
- Do NOT leave machine raised and unsecured while the tractor is parked.
- Do NOT travel with raised or open waste container.
- During transport, the pivoting drawbar should be set straight ahead.
- Do NOT transport people, animals and other objects on the machine
- Reckless driving and excessive speed may cause accidents.

F.2.6.588.04.1.EN

2.5 SAFETY RULES WHEN MAINTAINING HYDRAULIC SYSTEM AND PNEUMATIC SYSTEM

- When operating, the hydraulic and pneumatic systems are under high pressure.
- Regularly check the technical condition of the hydraulic lines and connections. Do NOT use the machine with leaky system.
- In the event of malfunction of the hydraulic or pneumatic system, do not use the machine until the malfunction is corrected.
- In the event of injuries being caused by pressurised hydraulic oil, contact a doctor immediately. Hydraulic oil may find its way under the skin and cause infections. In the event of contact of oil with eye, rinse with large quantity of water and in the event of the occurrence of irritation consult a doctor. In the event of contact of oil with skin wash the area of contact with water and soap. Do NOT apply organic solvents (petrol, kerosene).
- Use the hydraulic oil recommended by the Manufacturer.
- After changing the hydraulic oil, the used oil should be properly disposed of. Used oil or deteriorated oil should be stored in original containers or replacement containers resistant to hydrocarbons. Replacement containers must be clearly marked and appropriately stored.
- Do not store hydraulic oil in packaging designed for storing food or foodstuffs.
- Rubber hydraulic lines must be replaced every 4 years regardless of their technical condition.

F.2.6.588.05.1.EN

2.6 SAFE MAINTENANCE PRINCIPLES

- During the warranty period, any repairs may only be carried out by warranty service authorised by the Manufacturer. After the expiry of the warranty period it is recommended that possible repairs to the machine be performed by specialised workshops.
- In the event of any fault or damage, do not use the machine until the fault has been corrected.
- When servicing, use appropriate, close-fitting protective clothing, gloves, shoes, glasses and the correct tools.
- Any modification to the machine frees the manufacturer from any responsibility for damage or detriment to health which may arise as a result.
- Regularly check the condition of nut and bolt connections, in particular connections of drawbar eye and wheel nuts.
- Service inspections should be carried out according to the frequency specified in this Operator Manual.
- Before beginning repair work on hydraulic or pneumatic systems reduce oil or air pressure completely.
- Servicing and repair work should be carried out in line with the general principles of workplace health and safety. In the event of injury, the wound must be immediately cleaned and disinfected. In the event of more serious injuries, seek a doctor's advice.
- Repair, maintenance and cleaning work should be carried out with the carrier vehicle engine turned off and the ignition key removed. The carrying vehicle and the machine should be secured using parking brake and in addition chocks should be placed beneath machine's wheel. Ensure that unauthorised persons do not have access to the carrier vehicle cab.
- During maintenance or repair work, the machine may be unhitched from the carrying vehicle, but it must be secured with chocks and parking brake.
- Should it be necessary to change individual parts, use only those parts indicated by the Manufacturer. Non-adherence to these requirements may put the user and other people's health and life at risk, and also damage the machine and invalidate the warranty.
- In the event of work requiring the machine to be raised, use properly

certified hydraulic or mechanical lifts for this purpose. After lifting the machine, stable and durable supports must also be used. Do NOT carry out work under a machine, which has only been raised with the lift jack.

- The machine must not be supported using fragile elements (bricks or concrete blocks).
- After completing work associated with lubrication, remove excess oil or grease. The machine should be kept clean and tidy.
- Do NOT perform any independent repairs of hydraulic, pneumatic and electric components. In the event of damage to these elements, repair should be entrusted to an authorised service point or elements should be replaced with new ones.
- Do NOT install additional appliances or fittings not according to the specifications defined by the Manufacturer.
- The machine may only be towed when axles and wheels, lighting system and brakes are reliable.

F.2.6.588.06.1.EN

2.7 DRIVING ON PUBLIC ROADS

- When driving on public roads, observe all road traffic regulations in force in the country, in which the machine is used.
- Do not exceed the maximum speed resulting from road conditions and design restrictions. Adjust speed to the prevailing road conditions and other limitations arising from road traffic regulations.
- Chocks should be placed only under one wheel (one in front of the wheel, the other behind the wheel).
- The machine must NOT be left unsecured. When not connected to the tractor, the machine must be immobilised with parking brake and protected against rolling with chocks or other objects without sharp edges placed under the wheels.
- Before driving make sure that the machine is properly hitched to the carrying vehicle, especially if coupling bolts are secure.
- The vertical load carried by the drawbar eye of the machine affects the steering of the carrying vehicle.
- Do NOT drive when tank is raised.
- Before using the machine always check its technical condition, especially in terms of safety. In particular, check the technical condition of the hitch system, the axle system, the brake system, indicator lights and the connective elements of the hydraulic and electrical systems.
- Before driving off check that the parking brake is released.
- The machine is designed to operate on slopes up to 5°. Driving on steeper slopes may cause the machine to overturn due to loss of stability.
- While driving on public roads the machine and the carrying vehicle must be fitted with a certified or authorised reflective warning triangle.
- Periodically drain water from the air tank in pneumatic system. During frosts, freezing water may cause damage to pneumatic system components.
- Reckless driving and excessive speed may cause accidents.
- Prolonged driving across steep ground may lead to loss of braking efficiency.
- During reversing one should use the assistance of another person. During manoeuvring the assistant must stay at a safe distance from the danger

zone and be visible all the time to the tractor driver.

- Do NOT park the machine on slope.

F.2.6.588.07.1.EN

2.8 TYRES

- When working with tyres, the machine should be immobilised with parking brake and secured against rolling by placing chocks under wheel. Wheel may be taken off the machine axle when the machine is not loaded.
- Repair work on the wheels or tyres should be carried out by persons trained and entitled to do so. This work should be carried out using appropriate tools.
- Inspect tightness of wheel nuts after the first use of the machine, every 2 - 3 hours during first month of work and then every 30 hours of use. The inspection should be repeated individually if a wheel has been removed from the wheel axle. Wheel nuts should be tightened according to recommendations provided in sections: *TECHNICAL MAINTENANCE / WHEEL ASSEMBLY AND DISASSEMBLY, PERIODIC INSPECTIONS / INSPECT BOLT CONNECTIONS.*
- Avoid potholes, sudden manoeuvres or high speeds when turning.
- Check the tyre pressure regularly. Air pressure in tyres should be also checked during the whole day of intensive work. At high temperature and pressure, reduce load or speed. Do not release air from warm tyres to adjust the pressure or the tyres will be underinflated when temperatures return to normal.
- Protect tyre valves using suitable caps to avoid soiling.



IMPORTANT

Tire type: 235/75R17.5 T, TL, 143/141 J, TL.
Correct tire pressure: 7 ± 1 bar

F.2.6.588.08.1.EN

2.9 OPERATING PTO SHAFT.

- Before using the machine, carefully read the PTO shaft Operator Manual and follow all instructions.
- The machine may only be connected to the carrier vehicle by appropriately selected PTO shaft recommended by the Manufacturer.
- The drive shaft must be equipped with a cover. Do NOT use the shaft with damaged or missing guards. Each time the machine is used, always ensure that all the safety guards are in good condition and in place. Damaged or incomplete sub-assemblies must be exchanged for original new ones.
- The PTO shaft has markings on the casing, indicating which end of the shaft shall be connected to the carrying vehicle.
- Never use a damaged PTO shaft, it may cause an accident. A damaged shaft must be repaired or replaced.
- Disconnect the shaft drive each time when it is not necessary to drive the machine, or when the carrier vehicle and the machine are positioned at an unsuitable angle with regard to each other.
- The chains preventing the shaft cover from turning while the shaft is working, shall be secured to a fixed element of machine structure.
- Do NOT use the securing chains to support the shaft while the machine is parked or when transporting the machine.
- After connecting shaft, ensure that it is correctly and safely connected to the carrier vehicle and to the machine.
- Before starting the PTO drive, make sure that there are no bystanders (especially children) in the danger zone. The machine operator is obliged to ensure proper visibility of the working area.
- Before starting the PTO shaft, adjust its length according to the Operator Manual of the PTO shaft. If the shaft is too long, the shaft may be damaged at the headlands.
- Before starting PTO shaft, make certain that the PTO rotation direction is correct.
- During use, do not exceed the permissible rotational speed of the PTO shaft. Do not overload the PTO shaft and the machine.
- Before connecting or disconnecting the shaft, turn off the carrying vehicle

engine and remove the key from the ignition. Immobilise the vehicle with parking brake.

- During transport, the shaft must be stored in the horizontal position to avoid damage to safety guards or other protection elements.
- Do NOT wear loose clothing, straps or whatever that may become wrapped round the rotating drive shaft. Contact with rotating PTO shaft may cause severe injuries.
- Do NOT go over and under the shaft or stand on it equally during work as also when the machine is parked.
- When working in limited visibility conditions, use the carrying vehicle forward working lights to illuminate the articulated shaft and its vicinity.
- During shaft operation telescopic pipes must overlap by at least one third of their length.

F.2.6.588.09.1.EN

2.10 DESCRIPTION OF RESIDUAL RISK

Pronar Sp. z o. o. in Narew has made every effort to eliminate the risk of accidents. There is, however, a certain residual risk, which could lead to an accident, and this is connected mainly with the actions described below:

- using the machine for purposes other than those for which it is intended,
- being between the carrier vehicle and the machine while the engine is running and when the machine is being hitched,
- being on the machine when it operates,
- being near moving elements of the machine,
- operating the machine with removed or faulty safety guards,
- risk of trapping persons or animals inside the waste container,
- failure to keep a safe distance from dangerous areas during loading, disconnecting, connecting or unloading,
- operation of the machine by unauthorised persons or persons under the influence of alcohol or other intoxicating substances,
- making modifications to the machine without the consent of the Manufacturer,
- cleaning, maintenance and technical inspection while the machine is running,
- presence of persons or animals in areas invisible from the driver's position,
- risk of trapping persons or animals inside the waste container,
- oil leaks and sudden movement of elements resulting from line cracking,
- exceeding permissible ground speed.

The residual risk may be kept to a minimum by following the recommendations below:

- operate the machine in prudent and unhurried manner,
- reasonably apply all the remarks and recommendations stated in the Operator Manual,
- maintain a safe distance from prohibited or dangerous places
- carry out repairs and maintenance work in line with operating safety rules,
- repair and maintenance work should be carried out by persons trained to do so,
- use close fitting protective clothing and appropriate tools,
- ensure unauthorised persons have no access to the machine, especially

- children,
- a ban on being on the machine when it is operating,
- assistance of other persons while

manoeuvring the machine, due to limited visibility from the driver's position.

F.2.6.588.10.1.EN

2.11 INFORMATION AND WARNING DECALS

The machine is labelled with the information and warning decals mentioned in table 2.1. The arrangement of symbols is presented in (Figure 2.1). Throughout the machine use, you must ensure that any warning messages and information decals located on the machine are clear and legible. If any are destroyed or damaged, they must be replaced with new. Information and warning decals may be purchased directly from the Manufacturer or your

PRONAR dealer.

Part numbers of information decals are given in table (2.1) and in *Spare Parts List*. New assemblies, changed during repair, must be labelled once again with the appropriate safety signs. During machine cleaning do not use solvents, which may damage the coating of information decals and do not subject them to strong water jets.

F.2.6.588.11.1.EN

Table 2.1. Information and warning decals

LP.	Description	Catalog number
1	Warning decal. Danger caused by materials thrown out by the machine. Keep a safe distance from the operating machine.	12N-15000008
2	Warning decal. Pressurised liquid. Keep a safe distance from the operating machine.	12N-15000009
3	Warning decal. Engage service interlocks before entering the danger zone	100N-07000004
4	Warning decal. Before starting work, carefully read the Operator Manual.	35N-27000007
5	Warning decal. Do not reach into crushing space if elements may move. Danger of crushing hands or fingers.	35N-27000008
6	Information decal. An attachment point for transport.	35N-27000009
7	Warning decal. Danger of crushing to feet. Keep a safe distance.	117N-00000007

LP.	Description	Catalog number
8	Information decal. Water inlet marking	130N-36000005
9	Warning decal. Keep a safe distance from electric power lines. Danger of electric shock.	130N-36000008
10	Front outline marking	344N-97000001L
11	Brush tilt scale	344N-97000004
12	Rear clearance markings	R1F TYP 1 DIN11030
13	Information decal.	187N-00000033
14	Rear clearance markings	588N-18000007 588N-18000006
15	Front outline marking	588N-18000008
16	Decorative side decals	588N-18000001L 588N-18000001P 588N-18000002 588N-18000003 588N-18000004 588N-18000005
17	Information decal. PTO speed	344N-97000002
18	Information decal. PTO rotation direction	242N-96000004
19	Side clearance markings	344N-97000001L 344N-97000001P

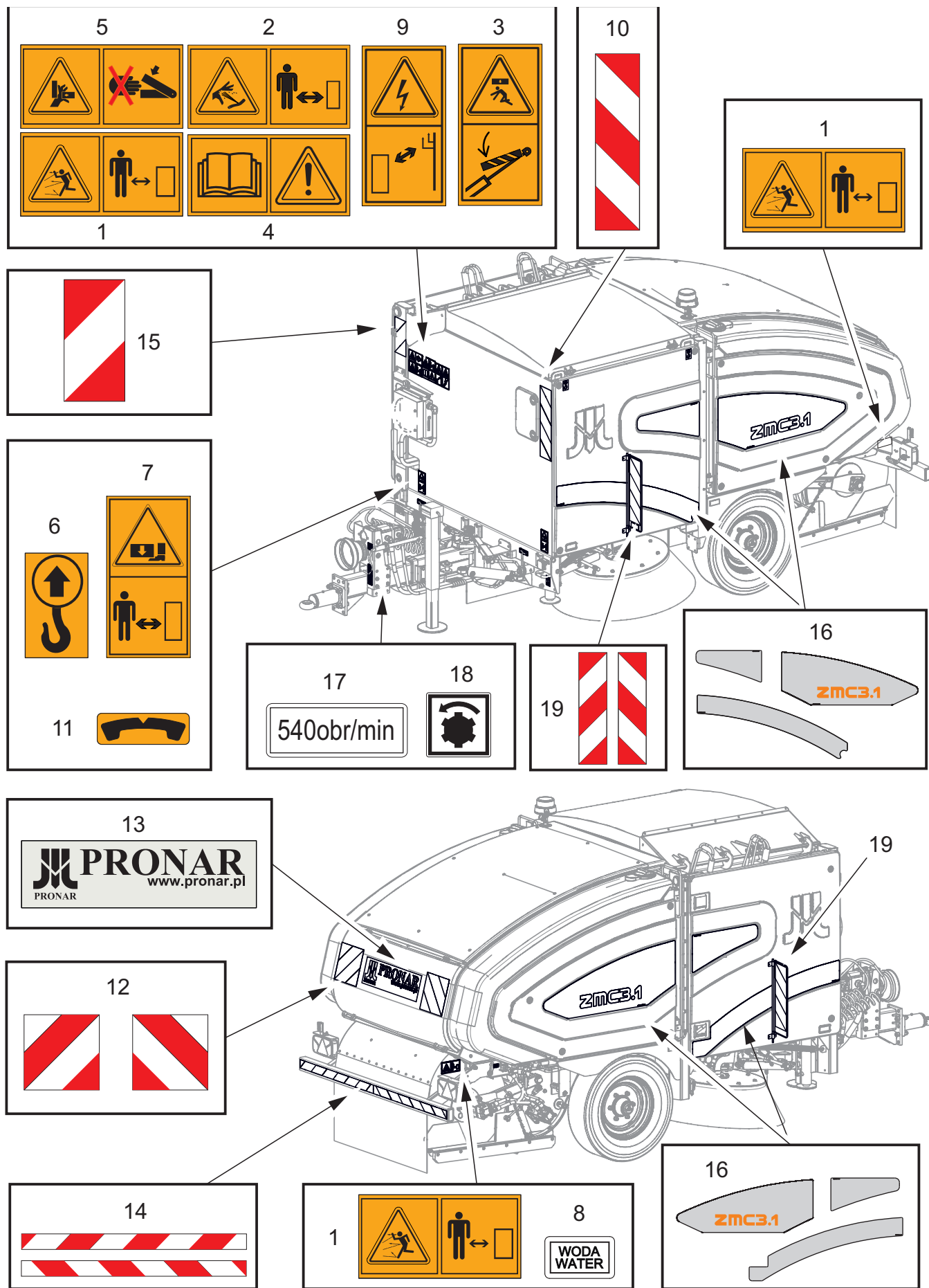

588-F.02-2

Figure 2.1 Locations of information and warning decals

SECTION 3

DESIGN AND OPERATION

3.1 TECHNICAL SPECIFICATION

Table 3.1. Standard equipment specification

Contents	Unit	
Technical specification		
Sweeping width - without side brush - with side brush	mm	2,400 - 2,700 3,100
Working speed*	km/h	1-20
Transport speed	km/h	40 / 25 (no certificate)
Waste container capacity	m ³	3
Machine drive	-	Power take-off shaft (PTO)
Control	-	control panel in the operator's cabin
Tare weight	kg	3,300
Maximum gross weight (DMC)	kg	7,000
Hydraulic system		
Oil tank capacity	dm ³	190
Nominal pressure in the system	MPa	16
Type of oil	-	L-HL46
Sweep unit		
Rotary disc brushes (2 items)	mm	d=760, D=1 100, H=260
Roller brush (1 item)	mm	D=750, L=1 100
Spray system		
Water tank cubic capacity	dm ³	1,120
Maximum spray pressure	bar	10
Dimensions		
Length with a lower drawbar with top drawbar	mm mm	5,140 4,980- 5,100
Width	mm	2,100
Height	mm	2,410
Emptying height	mm	2,200
Height with a raised tank	mm	4,420

* - speed depends on the amount of dirt

Level of noise emitted by the sweeper does not exceed 70 dB(A)

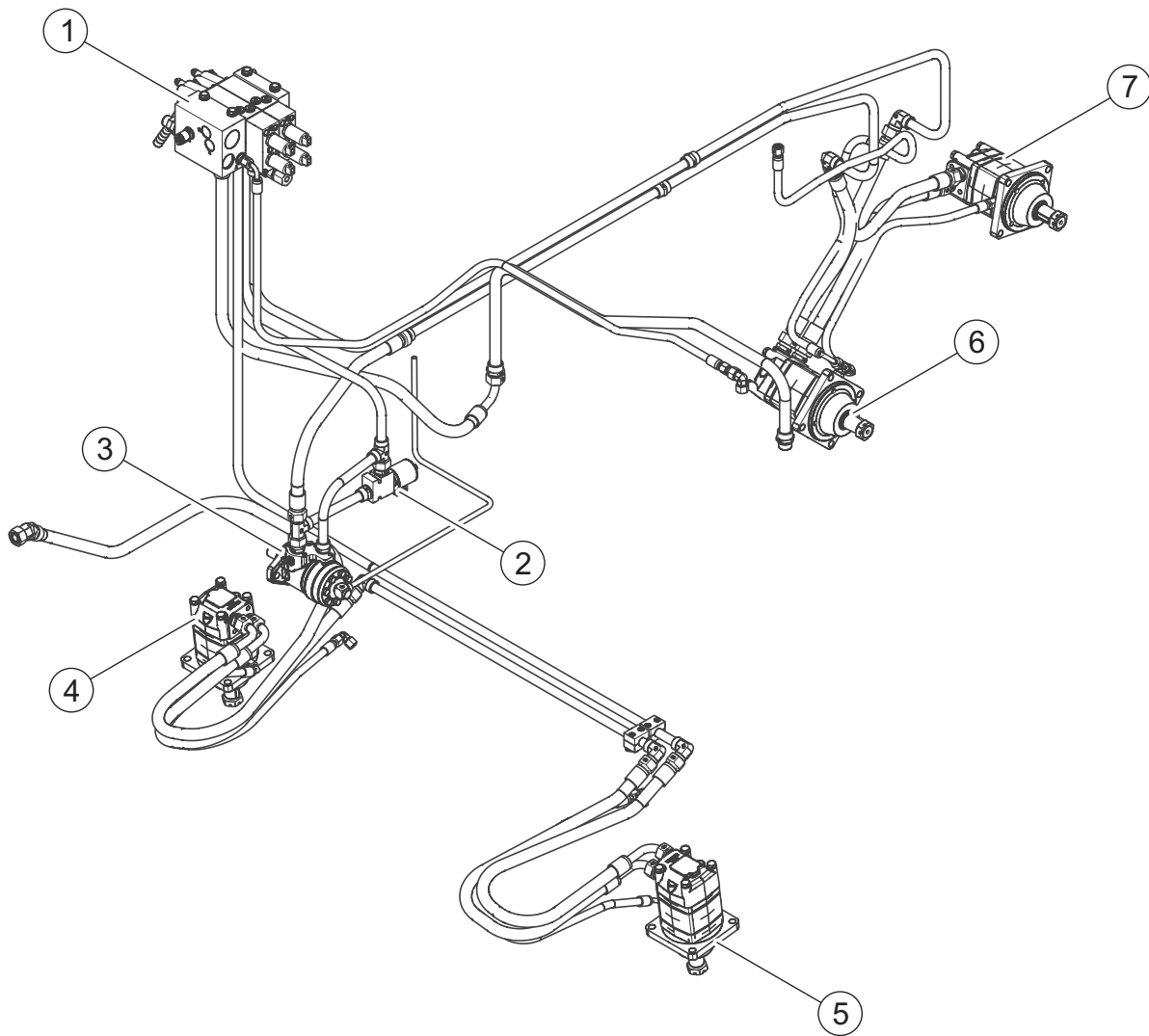

588-G.03-1

Figure 3.2 Drive hydraulic system

(1) manifold (2) solenoid valve

(4) right brush drive hydraulic motor

(6) conveyor drive hydraulic motor

(3) water pump drive hydraulic motor

(5) left brush drive hydraulic motor

(7) cylinder brush drive hydraulic motor

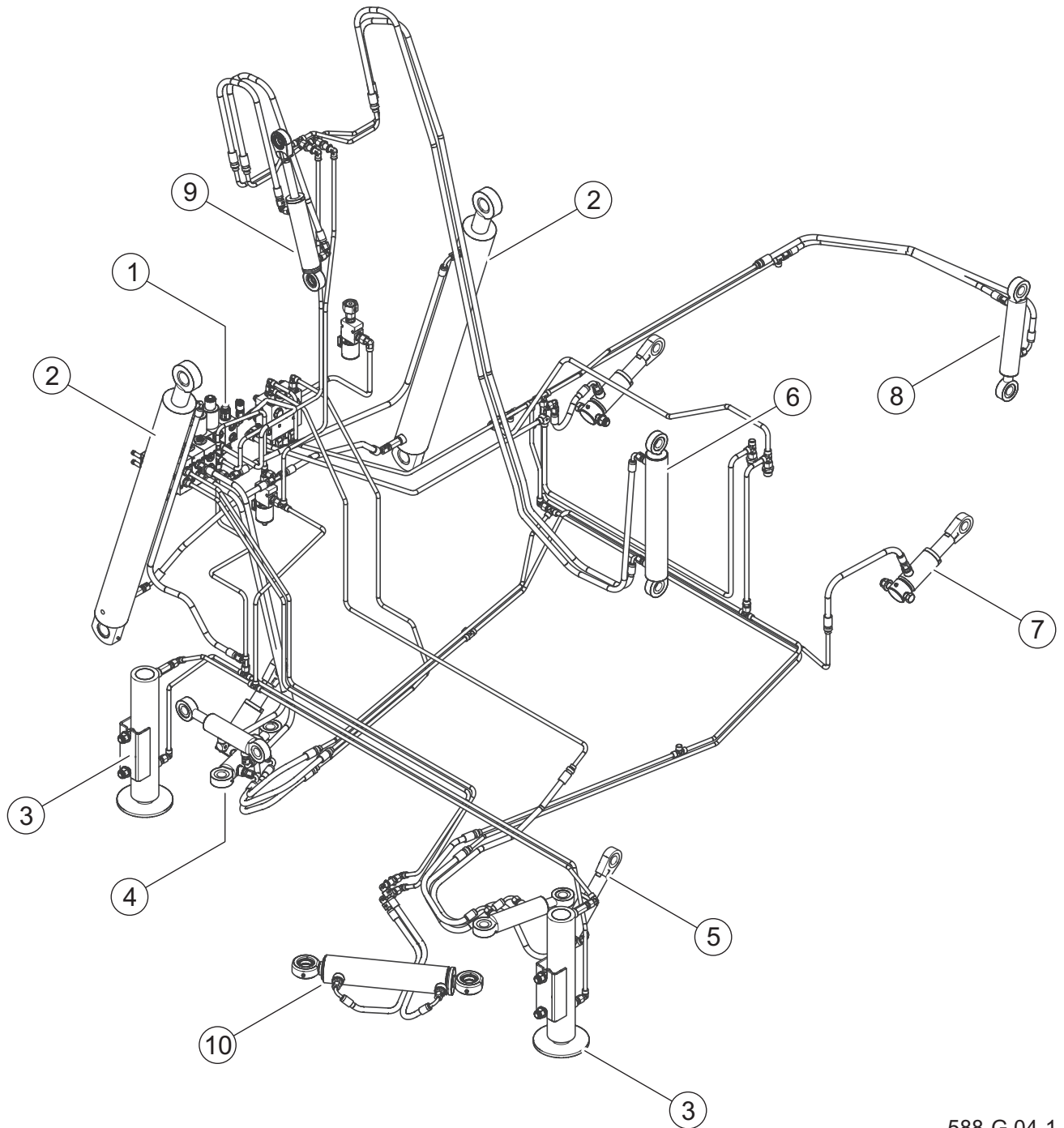

588-G.04-1

Figure 3.3 Control hydraulic system

- | | | |
|---------------------------------|--------------------------------------|-----------------------------------|
| (1) hydraulic divider | (2) waste container lifting cylinder | (3) support leg cylinder |
| (4) side brush tilting cylinder | (5) side brush lifting cylinder | (6) waste container side cylinder |
| (7) conveyor cylinder | (8) roller brush lifting cylinder | (9) container cover cylinder |
| (10) drawbar tilt cylinder | | |

G.2.6.588.02.1.EN

3.3 SWEEP SYSTEM

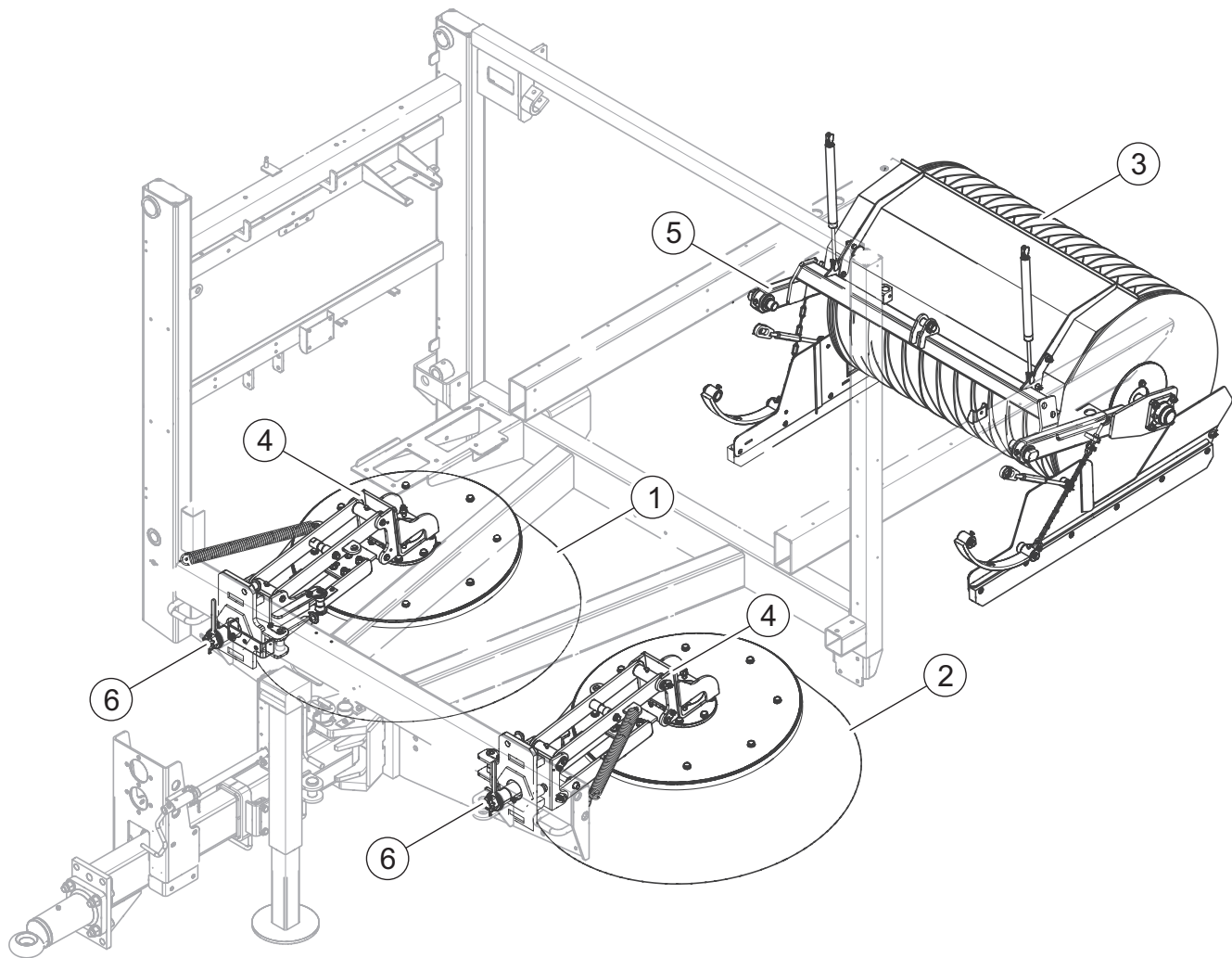

588-G.05-1

Figure 3.4 Sweep system

(1) right rotary disc brush

(2) left rotary disc brush

(3) roller brush

(4) rotary disc brush arm

(5) roller brush bracket

(6) brush tilt indicator

G.2.6.588.03.1.EN

3.4 SPRAY SYSTEM

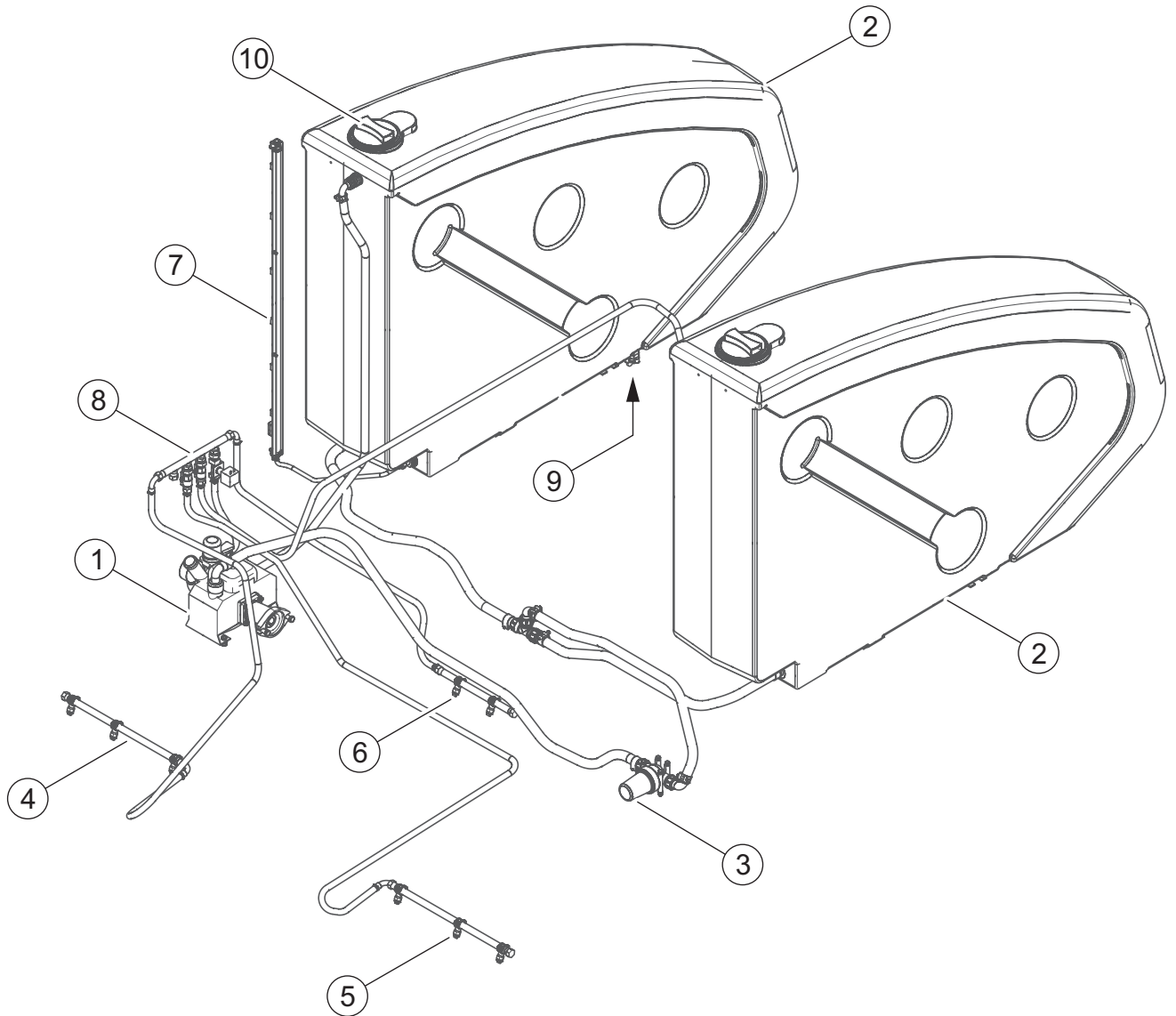

588-G.06-1

Figure 3.5 Spray system

- | | | | |
|--------------------------|---|---------------------------|---------------------------|
| (1) pump | (2) water tank | (3) filter | (4) right brush spray bar |
| (5) left brush spray bar | (6) roller brush spray bar | (7) water level indicator | |
| (8) valves | (9) drain valve with filling connection | (10) filler plug | |

G.2.6.588.04.1.EN

3.5 CONVEYOR AND WASTE CONTAINER

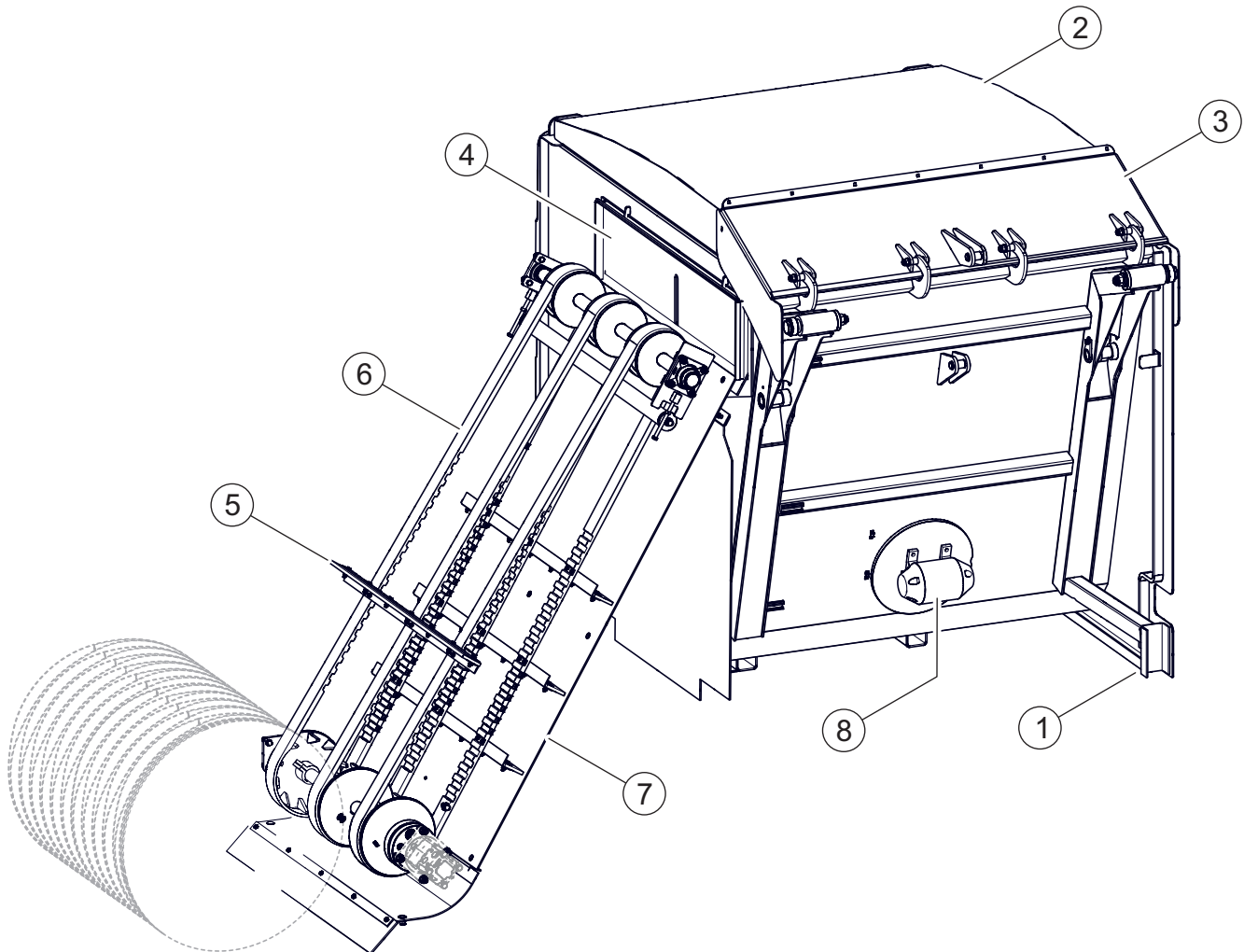

588-G.07-1

Figure 3.6 Conveyor and waste container

(1) waste container

(2) cover

(3) cover

(4) damper

(5) scraper

(6) belt

(7) skid plate

(8) vibrator (option)

G.2.6.588.05.1.EN

3.6 BRAKE SYSTEM

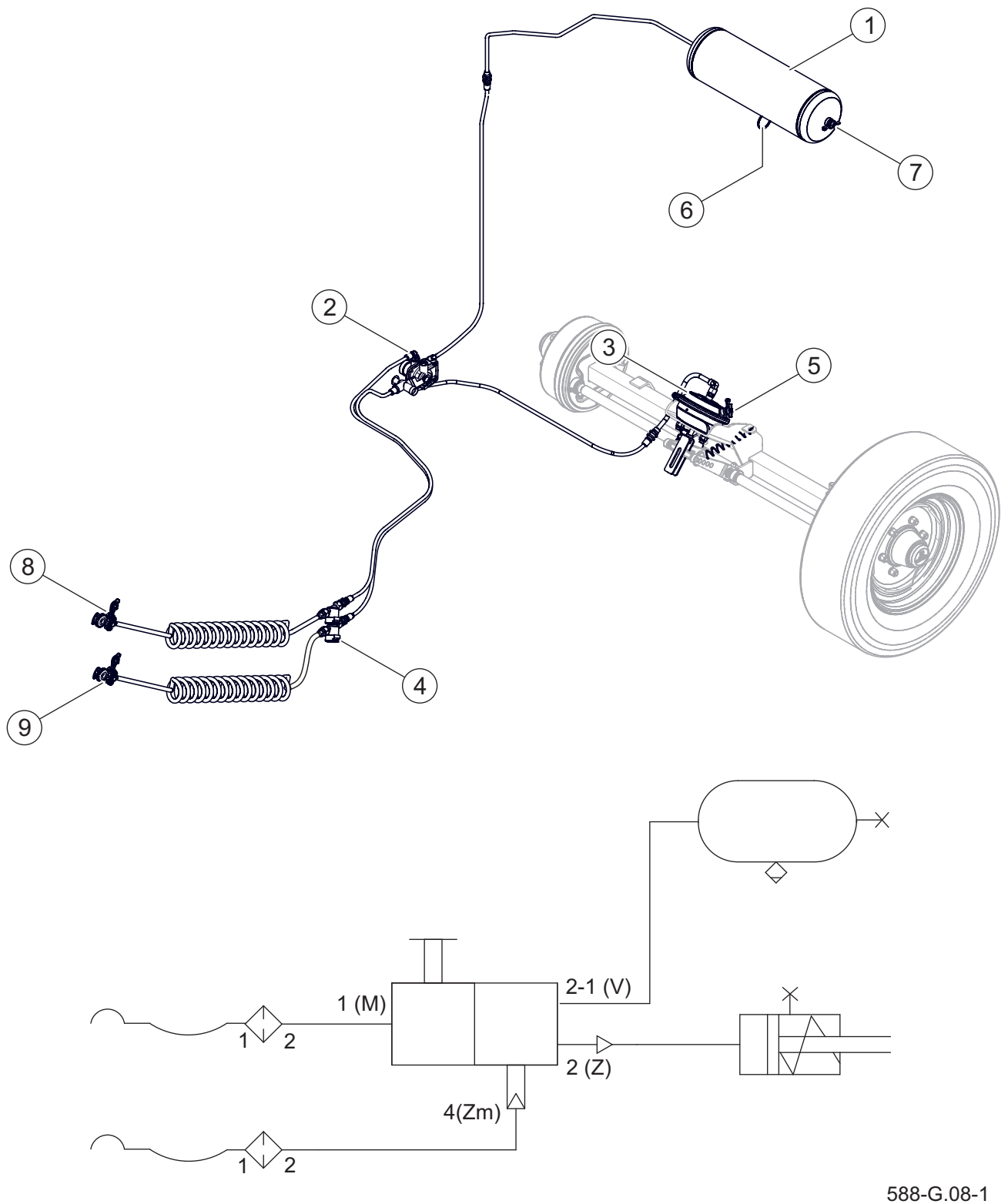

588-G.08-1

Figure 3.7 Pneumatic double-line braking system

- | | | |
|----------------------------------|---------------------------------|------------------------|
| (1) air tank | (2) control valve | (3) pneumatic cylinder |
| (4) air filter | (5) cylinder control connection | (6) drain valve |
| (7) container control connection | (8) "yellow" connector | (9) "red" connector |

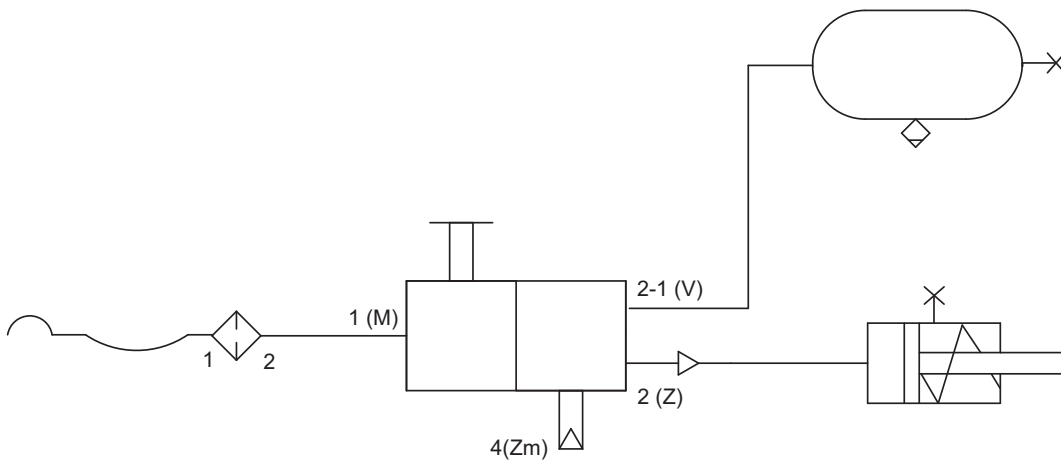
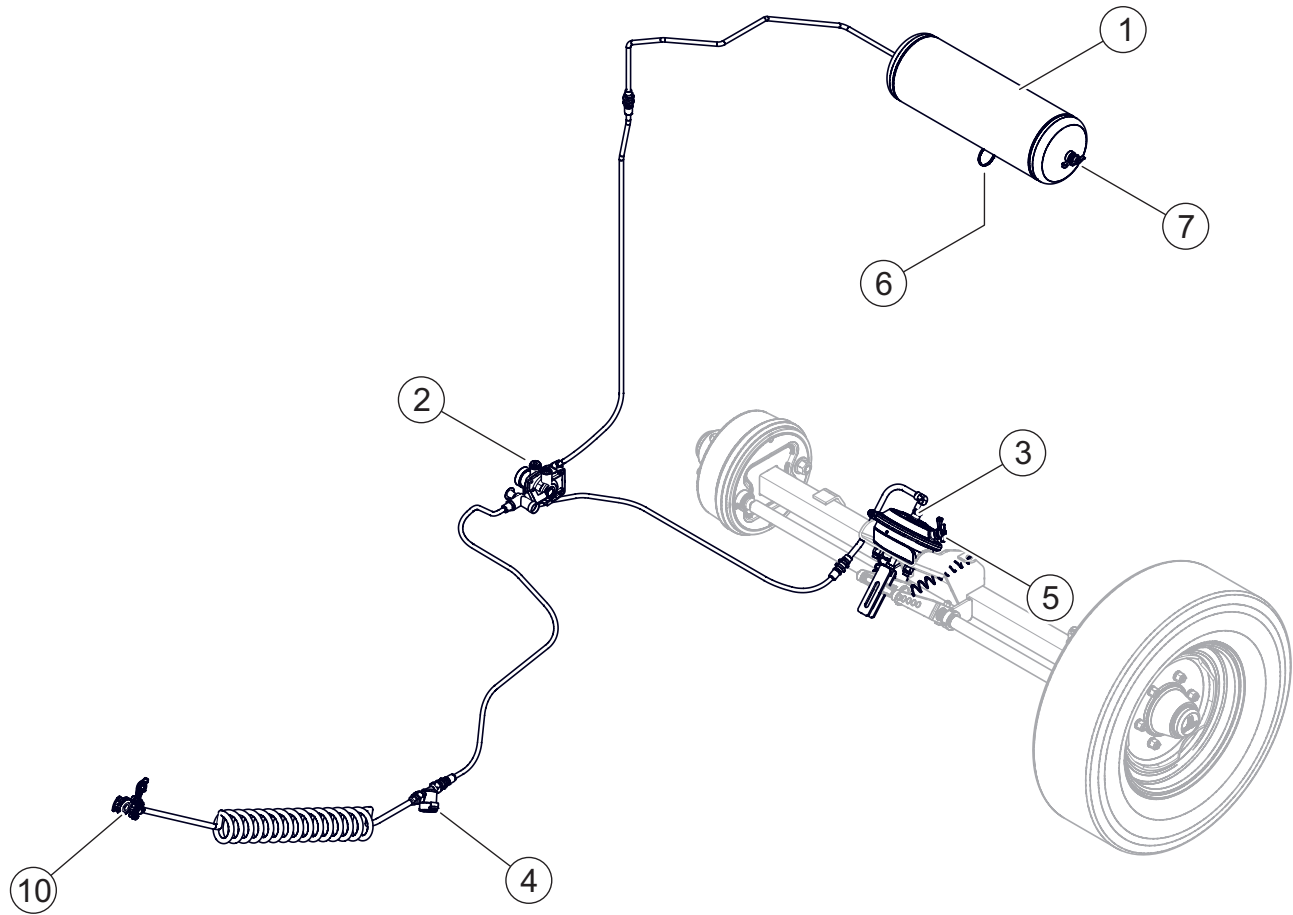

588-G.09-1

Figure 3.8 Single line pneumatic break system,

- | | | |
|----------------------------------|---------------------------------|------------------------|
| (1) air tank | (2) control valve | (3) pneumatic cylinder |
| (4) air filter | (5) cylinder control connection | (6) drain valve |
| (7) container control connection | (10) "black" connector | |

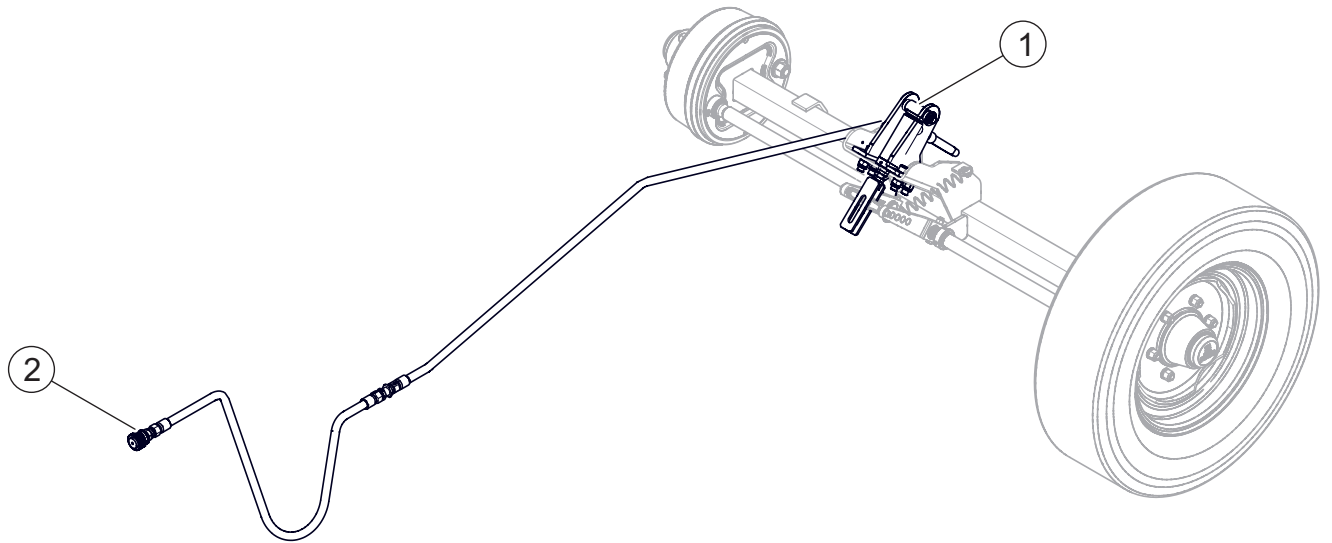

588-G.10-1

Figure 3.9 Hydraulic brake system (option)

(1) hydraulic cylinder

(2) quick coupler

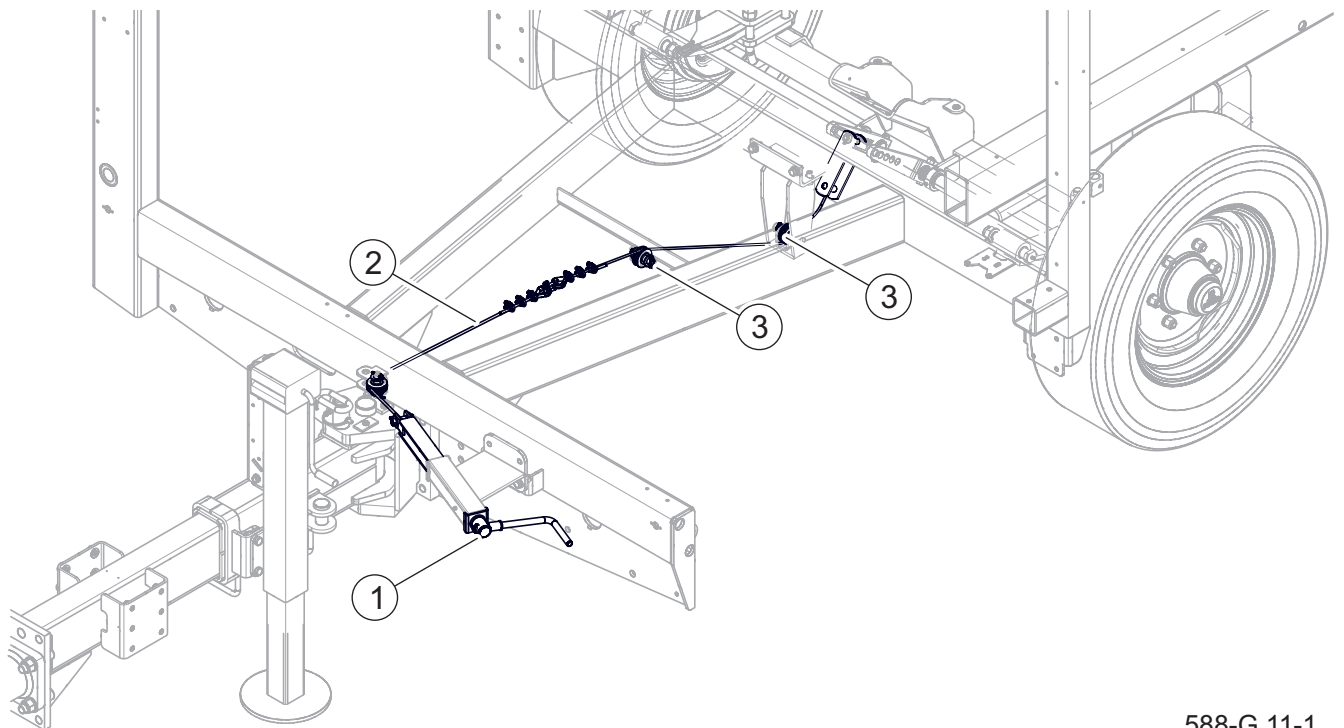

588-G.11-1

Figure 3.10 Parking brake

(1) brake crank mechanism

(2) cable

(3) guiding roller

SECTION 4

CONTROL PANEL

4.1 CONTROL PANEL

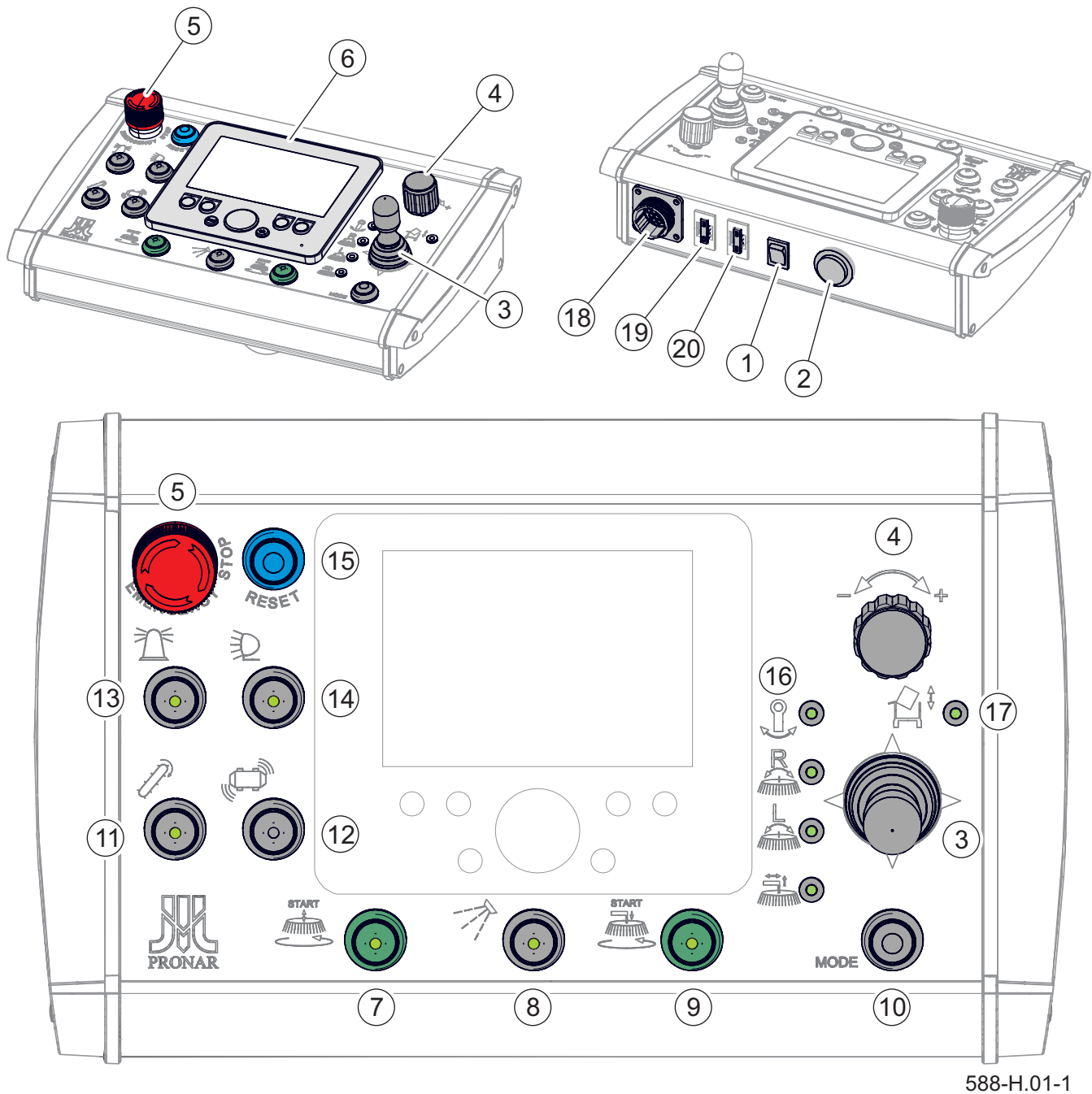













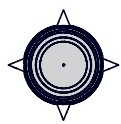

588-H.01-1

Figure 4.1 Control panel design
 The description of symbols in the figure is presented in Table 4.1

At the top of the control panel (Figure 4.1) there is an LCD display, function buttons, a knob for changing settings, an emergency stop button, and a joystick. On the back of the panel there is a power switch,

an acoustic signal, fuses and a socket for connecting the control cable. The individual elements of the panel are described in Table 4.1.

Table 4.1 Description of the control panel components (Figure 4.1)

LP	Symbol	Description	LP	Symbol	Description
1	-	Main switch of control panel and display	12		Waste container vibrator ON button (optional)
2	-	Audio signal (buzzer)	13		Warning lights on / off button
3		Multi-function joystick lever. The functions are selected with the "MODE" button (10) and indicated by the indicator (17) or one of the indicators (16)	14		Work area lighting on / off button (optional)
4		Settings adjustment knob. + increase value - decrease value	15		RESET button
5		Emergency STOP button	16		Tilt drawbar control indicator
6		LCD display	16		Right rotary disc brush tilt control indicator (option)
7		Sweeping unit brush up/down button	16		Left rotary disc brush tilt control indicator (option)
8		Spray system on / off button	16		Right side brush control indicator (option)
9		Right side brush up / down button (optional)	17		Waste container up / down indicator.
10		Joystick lever function selector button (3). The selected function is indicated by the appropriate indicator (16) or (17).	18	-	Control harness socket
11		Conveyor reverse motion on / off button.	19		Display fuse 2A

4.2 LCD PANEL

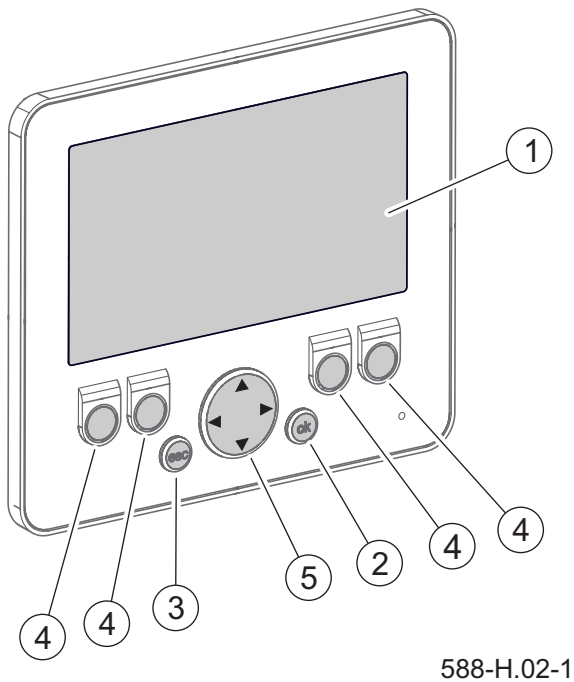







Figure 4.2 LCD panel

- (1) LCD
- (2) ESC button (exit)
- (3) OK button (confirm)
- (4) function buttons
- (5) navigation arrow keys (up, down, right, left)

The LCD panel (Figure 4.2) consists of a colour display (1) which displays information about the machine's operating setting, as well as alarm and warning conditions. Below the display there are function buttons (4) which are activated depending on the content displayed. Navigation arrow keys (5) are used to navigate the menu area and the selection is

Table 4.2 Panel controls

	ESC button (exit / cancel)
	OK button (confirm the selection)
	UP arrow key
	DOWN arrow key
	RIGHT arrow key
	LEFT arrow key

confirmed by pressing the OK button (2). Press the (3) ESC (exit) button to cancel the selection and exit to the main screen. In the lower right corner of the LCD panel there is a light indicating the operation.

When the control panel power supply is turned on, a short intro with the machine graphics and the software loading progress bar are displayed on the LCD display, and then the operator screen is launched. Press the ESC button to go to the main screen.

H.2.6.588.02.1.EN

4.3 LCD PANEL MENU

MAIN SCREEN

The operator screen starts automatically when the control panel is started.

Press the ESC button on the LCD panel to go to the main screen.

Using the arrow keys and the OK button you can go to the four menu options (1) from the main screen (Figure 4.3). Navigating between menu options is possible only from the main screen. Possible directions (3) for navigating in the menu are displayed at the bottom of the screen. The arrow keys below the display are used to

navigate through the menu. Press the ESC (exit) button to go from another screen to the main screen.

At the very top of the main screen there is an information bar (2) on which icons of the machine's components operation as well as alarm and warning notifications are displayed. The information bar is shown on every menu screen because it displays the most important information related to the operation of the machine.

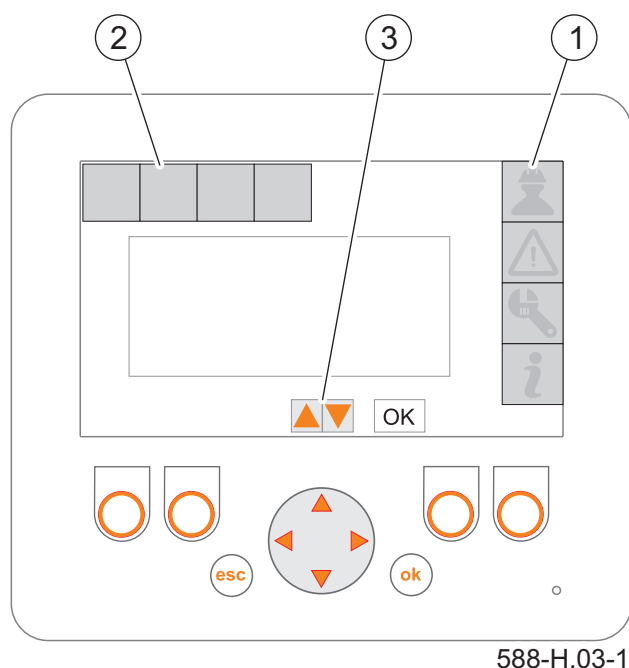

Figure 4.3 Main screen

(1) menu icons

(2) upper information bar

(3) directions for navigating through the menu

Table 4.3 HOME menu icons

	Operator screen
	Alarms screen
	Settings screen.
	Information screen
	Navigate the menu

OPERATOR SCREEN



The operator screen (Figure 4.4) starts automatically when the control panel is started and can be used to change machine settings and monitor operation. There is an information bar at the top of the operator screen.

There are counters (1) in the centre of the screen informing about the sweeping time and machine operation time.

Information on the operation of such

components as warning lights, the working area light, vibrator, fan is displayed on the central information bar (2). Active icons of the central bar (2) are highlighted in green.

On both sides of the screen there are vertical indicators (3, 4, 5) for changing the machine settings. To select an indicator, press the suitable function key (F1, F2, F3, F4) located under it. The selected setting will be highlighted in blue and it will be possible to change it using the arrow keys (7) below the screen or the knob (8)

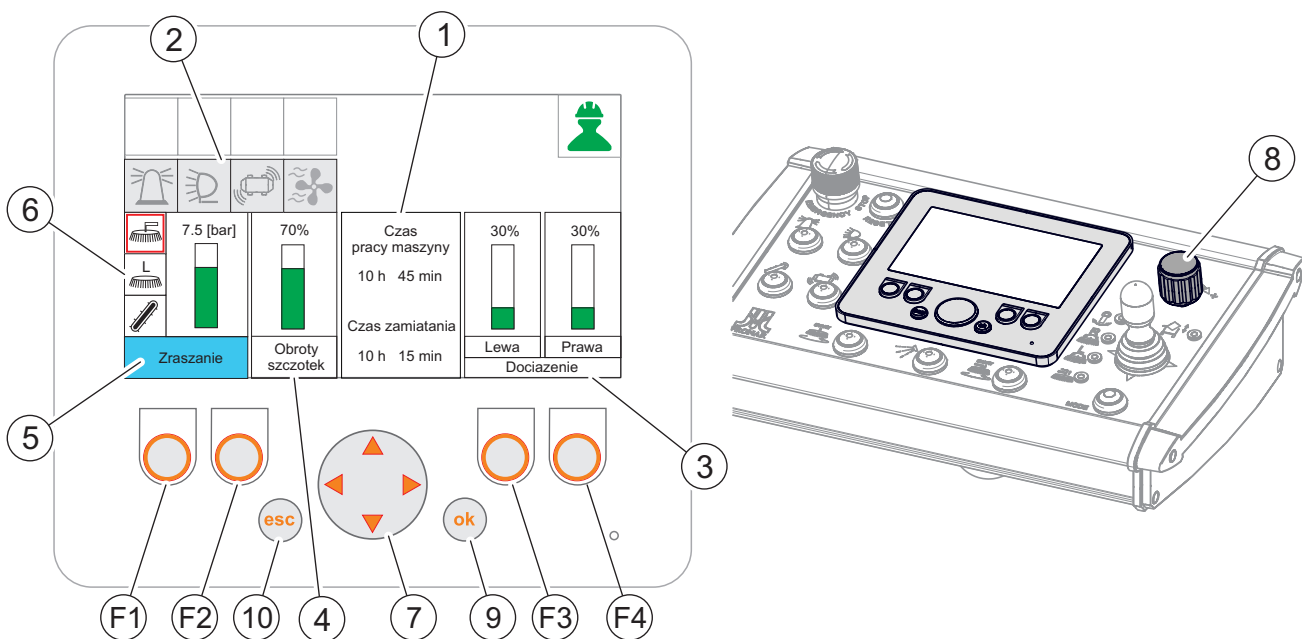

588-H.04-1

Figure 4.4 Operator screen

- (1) counters
- (2) information bar
- (3) rotary disc brush load indicator
- (4) brush rotation indicator
- (5) spray pressure indicator (option)
- (6) spray functions (optional)
- (7) arrow keys
- (8) settings adjust knob
- (9) OK button (confirm)
- (10) ESC button (exit)
- (F1) spray indicator function key
- (F2) brush rotation indicator function key
- (F3) left disc brush load indicator function key
- (F4) right disc brush load indicator function key

on the control panel.

The indicator (3) allows you to change the load of the right and left rotary disc brushes independently. You can make changes using the arrow key button (7) up / down or the knob (8). As the number on the indicator increases, the pressure of the brush on the ground increases.







The indicator (4) can be used to change the rotational speed of the rotary disc brushes. You can make changes using the arrow key button (7) up / down or the knob (8). Increasing the number on the indicator increases the rotational speed.

The sweeper can be equipped with two spraying options:

- water pressure adjustment from the control panel using the indicator (5).
- electric, independent switching of spraying nozzles of the conveyor and the left rotary disc brush.

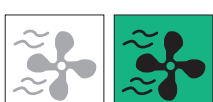
To enable the spraying options (6), select the SPRAYING button (5) by pressing the function button (F1), then use the arrow key (7) to highlight the selected icon with the red frame and confirm by pressing the

Table 4.4 Operator screen icons

	Warning lighting <i>active- green</i>
	Working zone lights <i>active- green</i>
	Waste container vibrator <i>active- green</i>
	Oil cooler fan. (starts up automatically above 55°C) <i>active- green</i>
	Side brush spray (option) <i>active- white</i>
	Left rotary disc brush spray <i>active- white</i>
	Conveyor spray <i>active- white</i>

OK button (9).

In a sweeper with an additional side brush (option), it is possible to switch on spraying on the operator's screen.

The active spray unit are highlighted in white.

ALARMS SCREEN



On the alarm screen (Figure 4.5) there are notifications about problems in the machine operation. If an alarm or warning occurs, the LCD will automatically switch to the alarm screen. If an alarm is active, an appropriate icon will be displayed on the top bar and in the alarm menu. To view alarms and warnings, press the left arrow key (7) and highlight the selected element with a red frame. Additional information (e.g. number of occurrences, duration) will be displayed below the selected item. To navigate through the menu of the alarm screen, use the right / left arrow keys. Use the right / left arrow keys to navigate through the screen pages. If the icon is red, it means that the fault is active. The number of occurrences and the duration of

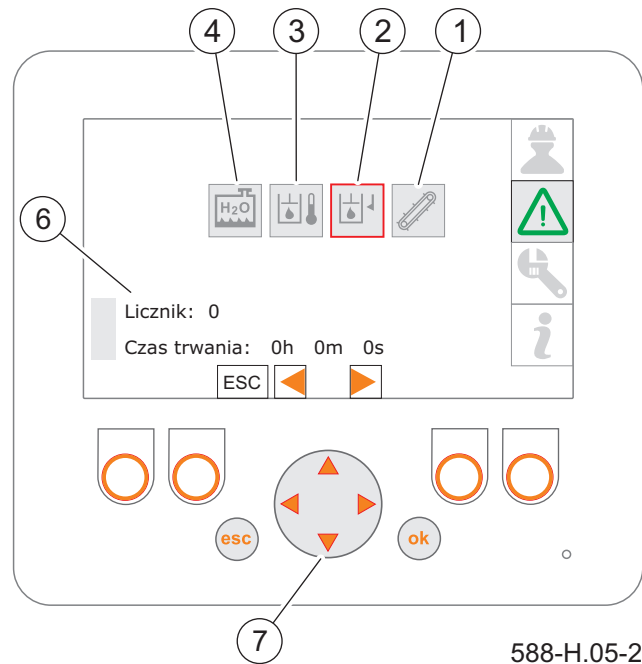

588-H.05-2

Figure 4.5 Alarms screen

- (1) conveyor belt blocked
- (2) low oil level
- (3) high oil temperature
- (4) low water level
- (6) additional information
- (7) arrow key

each alarm and warning are counted and stored. These values are non-erasable.

SETTINGS SCREEN



On the settings screen (Figure 4.6) you can change the display language (1), adjust the LCD brightness (2), reset the temporary sweeping timer (3) and activate the pressure washer (3) (optional). Use the arrow keys to navigate the screen. To select the required function, highlight it in blue with the arrow key and press the OK button.

To change the display language, highlight the LANGUAGE item (1) on the settings screen (Figure 4.6) and confirm with OK. In the LANGUAGE SELECTION window (Figure 4.7), use the right / left arrow key

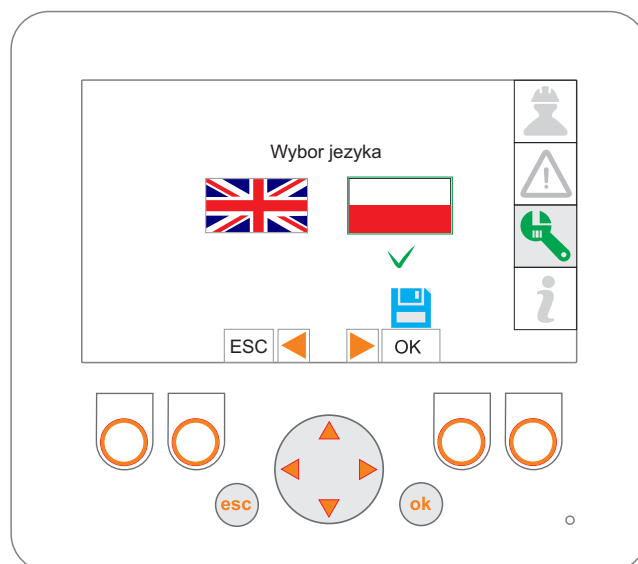

588-H.07-1

Figure 4.7 Change the language to highlight the country's flag and confirm with OK. Press the ESC button to return to the previous screen.

The screen brightness (Figure 4.8) can

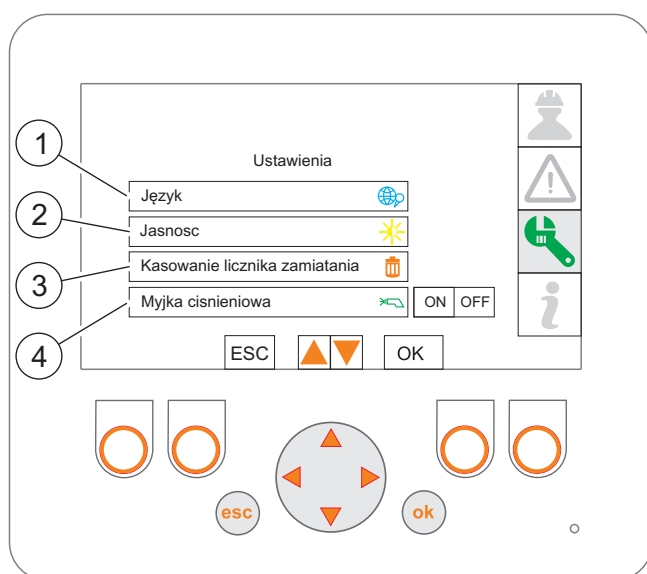

588-H.06-1

Figure 4.6 Settings screen.
 (1) change the menu language
 (2) change the LCD brightness
 (3) reset the temporary counter
 (4) activate the pressure washer (option)

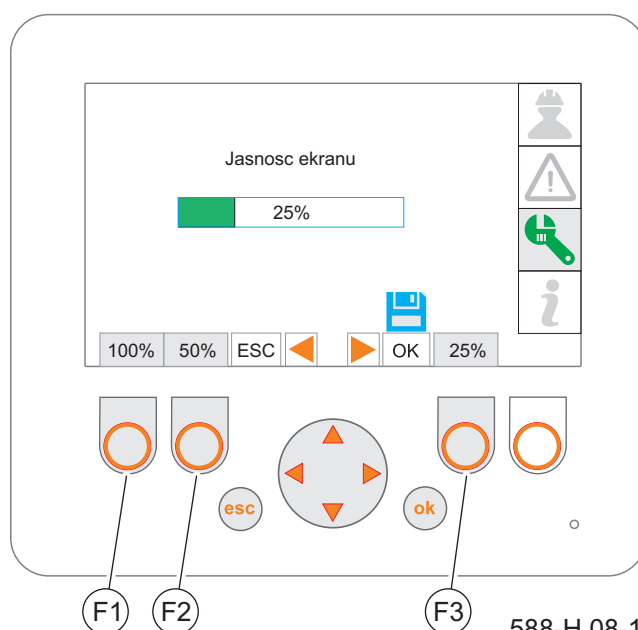

588-H.08-1

Figure 4.8 Settings screen. Screen brightness
 (F1) set display brightness to 100%
 (F2) set display brightness to 50%
 (F3) set display brightness to 25%

be changed in steps (25%, 50%, 100%) using the F1, F2, F3 function buttons or smoothly with the right / left arrow key by changing the value by 1%. Confirm the set brightness with the OK button.

To enable the pressure washer, select PRESSURE WASHER from the menu on the settings screen (Figure 4.9), select the ON option with the arrow key and confirm your choice with the OK button.

The icon (2) with the washer symbol highlighted in white will be displayed on the upper bar of the operator panel. After activation, the washer can be started by pressing the button on the machine.

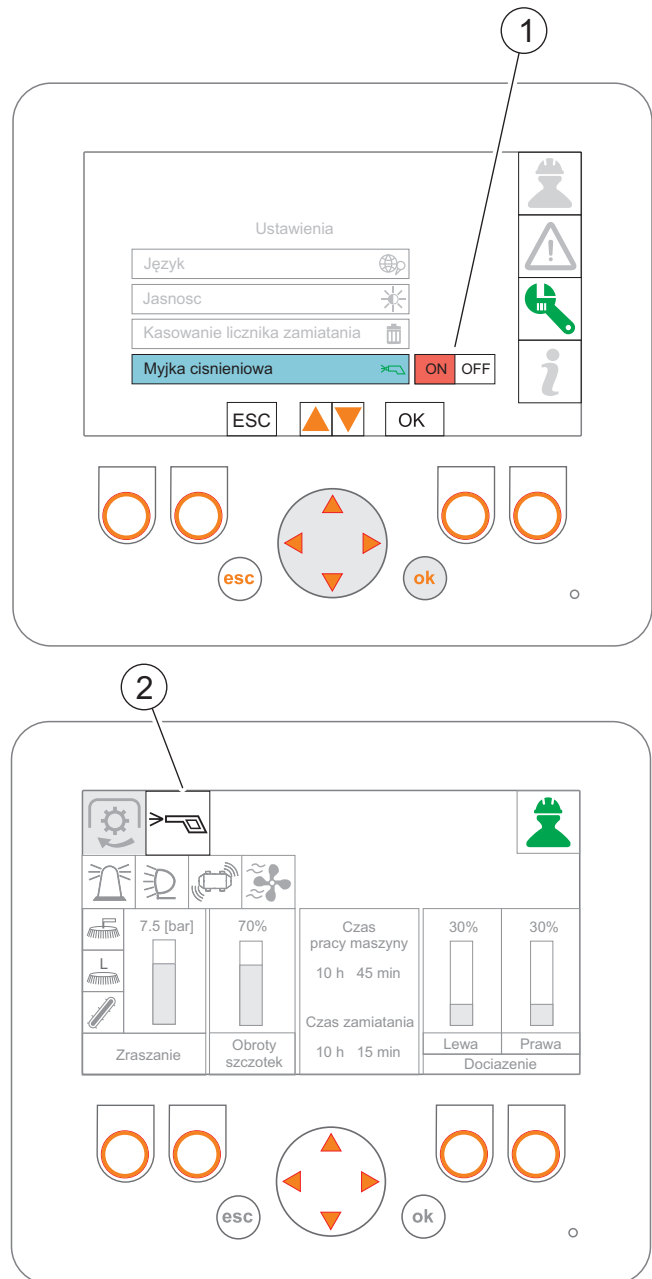

588-H.09-1

Figure 4.9 Active the pressure washer
 (1) pressure washer ON / OFF switch
 (2) active washer icon (white)

INFORMATION SCREEN

In the INPUT / OUTPUT menu on the information screen, a list of input and output signals with the current operating status is displayed (Figure 4.11). The bottom of the screen shows the current page number and the total number of pages (3). Use the right / left arrow key to navigate to the next pages.

The PROGRAMME INFORMATION menu (Figure 4.12) displays detailed information about the PLC and LCD firmware.

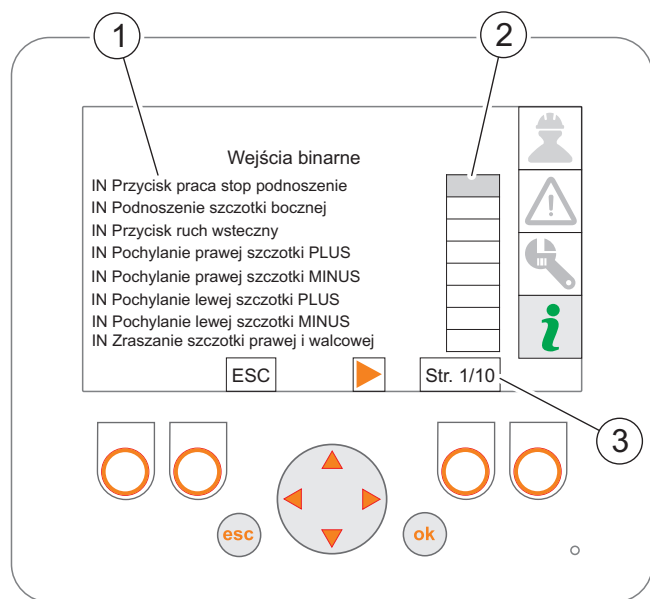

588-H.11-1

Figure 4.11 Information screen Inputs / Outputs

- (1) list of input and output signals
- (2) signal status
- (3) menu page number / total number of pages

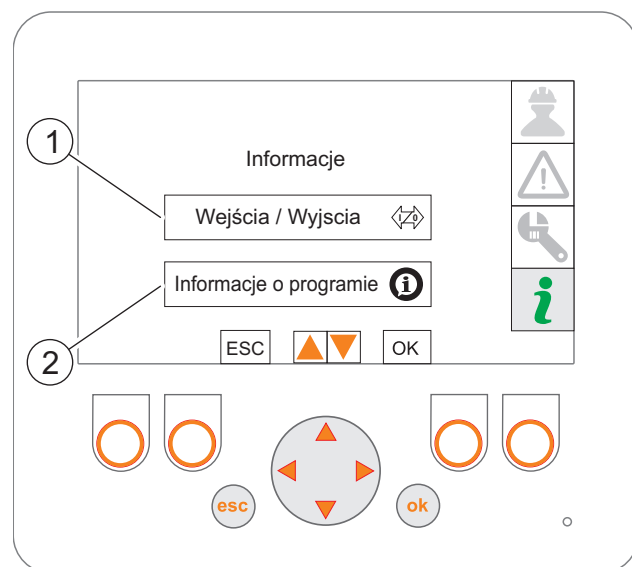

588-H.10-1

Figure 4.10 Information screen Main menu
(1) controller inputs / outputs
(2) software version info













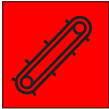





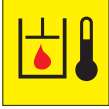

588-H.12-1

Figure 4.12 Information screen Programme info

- (1) list of input and output signals
- (2) signal status
- (3) menu page number / total number of pages

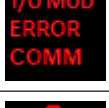
4.4 ALARMS AND WARNINGS

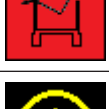
Table 4.5 Alarm screen icons

	Alarm. Red. Conveyor belt blocked. (Oil pressure over 85 bar)		Warning. Yellow Left cover open
	Alarm. Red. Low level of hydraulic oil in the tank.		Warning. Yellow Right cover open
	Alarm. Red. High oil temperature (above 75°C)		Warning. Yellow Back cover open
	Warning. Yellow High oil temperature (70°C-75°C)		Warning. Yellow Right and back covers open
	Warning. Yellow Low tank water level (pressure washer off)		Warning. Yellow left and rear covers open
	Machine emergency stop		Warning. Yellow right and left covers open
	Controller communication failure		Warning. Yellow All covers open
	I/O module communication failure		
	Alarm has occurred. Red.		
	Warning occurred. Yellow		
	Alarm. Red. Waste container raised		
	Output failure. Yellow		

SECTION 5

CORRECT USE

5.1 PREPARE FOR WORK



DANGER

Before using the machine, the user must carefully read this Operator Manual. Careless and incorrect use and operation of the machine, and failure to follow instructions in this Operator Manual is dangerous to your life and health.

The manufacturer guarantees that the machine is fully operational and has been checked according to quality control procedures and is ready for use. This does not release the user from an obligation to check the machine's condition after delivery and before first use. The machine is delivered to the user completely assembled and does not require any additional assembly operations, except for the control panel, which must be connected to the machine and to the carrier vehicle battery. Prior to connecting to the carrier



DANGER

The machine must never be used by persons, who are not authorised to drive agricultural tractors (carrier vehicles), including children and people under the influence of alcohol or other drugs. Non-compliance with the safety rules of this Operator Manual can be dangerous to the health and life of the operator and others.



DANGER

Before starting the machine, ensure that there are no bystanders in the danger zone.



IMPORTANT

Before using the machine always check its technical condition. In particular, check the technical condition of the suspension system, drive system, protective covers and lighting (direction indicators, stop lamps, parking lights), condition of the blades and their mounting.

Check the tension of the conveyor belts, the technical condition and inclination of the scrapers, the condition of the flexible clutch and any contamination.



IMPORTANT

Before starting work, check all lubrication points and lubricate the machine if necessary.

vehicle (tractor), machine operator must verify the machine technical condition.

In order to do this:

- the user must carefully read this Operator Manual and observe all recommendations, understand the design and the principle of machine operation,
- make sure that the machine's linkage is compatible with that of the carrier vehicle (tractor),
- make sure that power take-off shaft is compatible, e.g. tip type, RPM, rotation direction,
- make sure that the telescopic articulated shaft (PTO) can be connected to the tractor (the shaft should be compatible with the tractor in terms of

length, type, strength, etc. - see the manufacturer's operating manual),

- check technical condition of the breaking and electrical system,
- inspect machine's individual components for mechanical damage resulting from incorrect transport (dents, piercing, bent or broken components),
- check technical condition of the brushes and their mounting,
- check the technical condition of the suspension system components, guards and safety pins and if mounting is correct,
- check all lubrication points, lubricate the machine if necessary.

If all the above checks have been performed and there is no doubt as to the machine's good technical condition, it can be connected to carrier vehicle, started and all its individual systems checked. In order to do this:



DANGER

When starting machine for the first time as well as after servicing the hydraulic system, extreme caution should be exercised because the aerated hydraulic system causes accelerated movement of the powered components.

- check and adjust the height of drawbar to the carrier vehicle hitch,
- check and adjust the height of the multiplier gear box,
- hitch the machine to carrier vehicle (see 4.3 HITCHING TO CARRIER VEHICLE),
- after connecting the electrical system, control panel and brake system lines, check the correct operation of individual machine systems and check the hydraulic system for tightness.

In the event of a disruption in the operation of the machine immediately discontinue its use, find and remove the fault. If a fault cannot be rectified or the repair could void the warranty, please contact the Manufacturer for additional clarifications.

I.2.6.588.02.1.EN

5.2 TECHNICAL INSPECTION

Table 5.1 Review categories

Category	Description	Responsible	Frequency of execution
A	Daily review	Operator	Every day before first start-up or every 10 hours of continuous shift work
B	Maintenance	Operator	Periodic inspections are performed every 50 hours of machine operation. A daily inspection should be performed each time before this inspection.
C	Maintenance	Operator	Inspection performed periodically every 3 months. Daily inspections and inspections every 50 hours should be performed before this inspection.
D	Maintenance	Operator	Inspection performed periodically every 6 months. Before performing this inspection, a daily inspection should be performed, as well as every 50 hours and every 3 months of machine use.
E	Maintenance	Operator	Periodic inspections are performed every 12 months or 500 hours of machine operation (whichever comes first). Before this inspection, perform a daily inspection, every 50 hours, every 3 months, and every 6 months of machine operation.
F	Maintenance	Service ⁽¹⁾	Inspection every 4 years of trailer use.

⁽¹⁾ - post-warranty service

Table 5.2 Technical inspection schedule

Description of activities	A	B	C	D	E	F
Checking the technical condition of protective covers and warning stickers	•					
Check the tension of the conveyor belts. Condition of scrapers, flexible coupling, contamination build-up, skew	•					
Inspection of the sweeping unit (technical condition and setting of brushes and sliders)	•					
Oil level in the multiplier gear box	•					
Oil level in the hydraulic system tank	•					
Checking the air pressure in the tires and the technical condition of the tires	•					
Air tank drainage	•					
Inspection of electrical, hydraulic and pneumatic connection plugs and sockets.	•					
Checking the operation of the electrical and braking systems.	•					
Checking the water level in the sprinkler system tank.	•					
Checking the oil level in the sprinkler system pump	•					
Technical condition of the telescopic articulated shaft, covers and safety chains	•					
Hydraulic system inspection		•				
Checking the tightening of the road wheels		•				
Cleaning the air filters of the pneumatic system			•			
Checking and adjusting wheel bearing clearance				•		
Tightening torques for screw connections				•		
Changing the oil in the multiplier gear box					•	
Wymiana oleju i filtrów układu hydraulicznego					•	
Changing the oil and filters of the hydraulic system						•
Lubrication	According to the point: <i>LUBRICATION</i>					

5.3 CONNECT THE MACHINE TO THE CARRIER VEHICLE (TRACTOR)

ADAPT THE DRAWBAR TO THE LOWER HITCH OF THE CARRIER VEHICLE

The .0 sweeper may be hitched to agricultural tractor or another carrier vehicle that meets the requirements presented in Table 1.1. Requirements for carrier



DANGER

Use only genuine pins and safeguards to hitch the machine to the carrier vehicle.

vehicle.

For optimum operation, the sweeper frame should be positioned horizontally during operation. To do this, the machine's

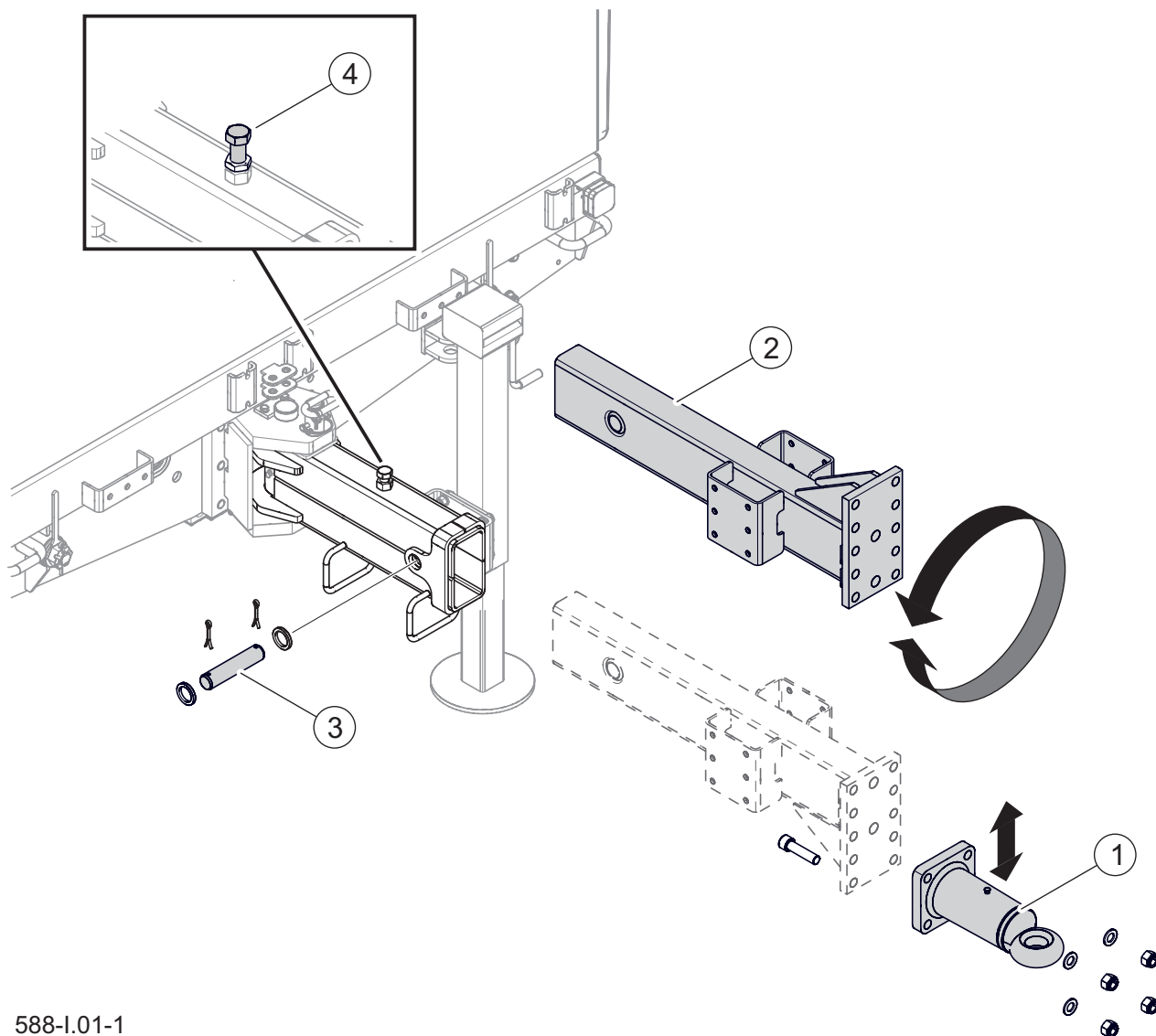

588-l.01-1

Figure 5.1 Adapt the machine to the lower hitch of the carrier vehicle

(1) rotating drawbar eye (2) drawbar (3) pin (4) compression bolt

drawbar should be positioned properly. If the machine is adapted to be connected with the lower hitch of the carrying vehicle, change the tie rod (1) fastening holes in order to change the height of the drawbar (Figure 5.1). After sliding out from the guide, the drawbar (2) can be rotated to achieve a larger adjustment range of the drawbar eye (1) height. To do this, remove the pin (3), loosen the clamping bolt (4), pull the drawbar out of the guide, turn it and fix it in the guide. Secure the drawbar with the bolt (3) and tighten the clamping bolt (4).

The rotating drawbar eye height (measured from the ground) can be adjusted within the range of 285 - 505 mm, by steps of 60 mm. (Figure 5.1). The height of the multiplier gear box shaft driven from the carrier's PTO can be adjusted by changing the mounting of the bracket on the drawbar or the multiplier gear box position.

ADAPT THE DRAWBAR TO THE UPPER HITCH OF THE CARRIER VEHICLE

Machines equipped with a drawbar to connect to the upper hitch of the carrier

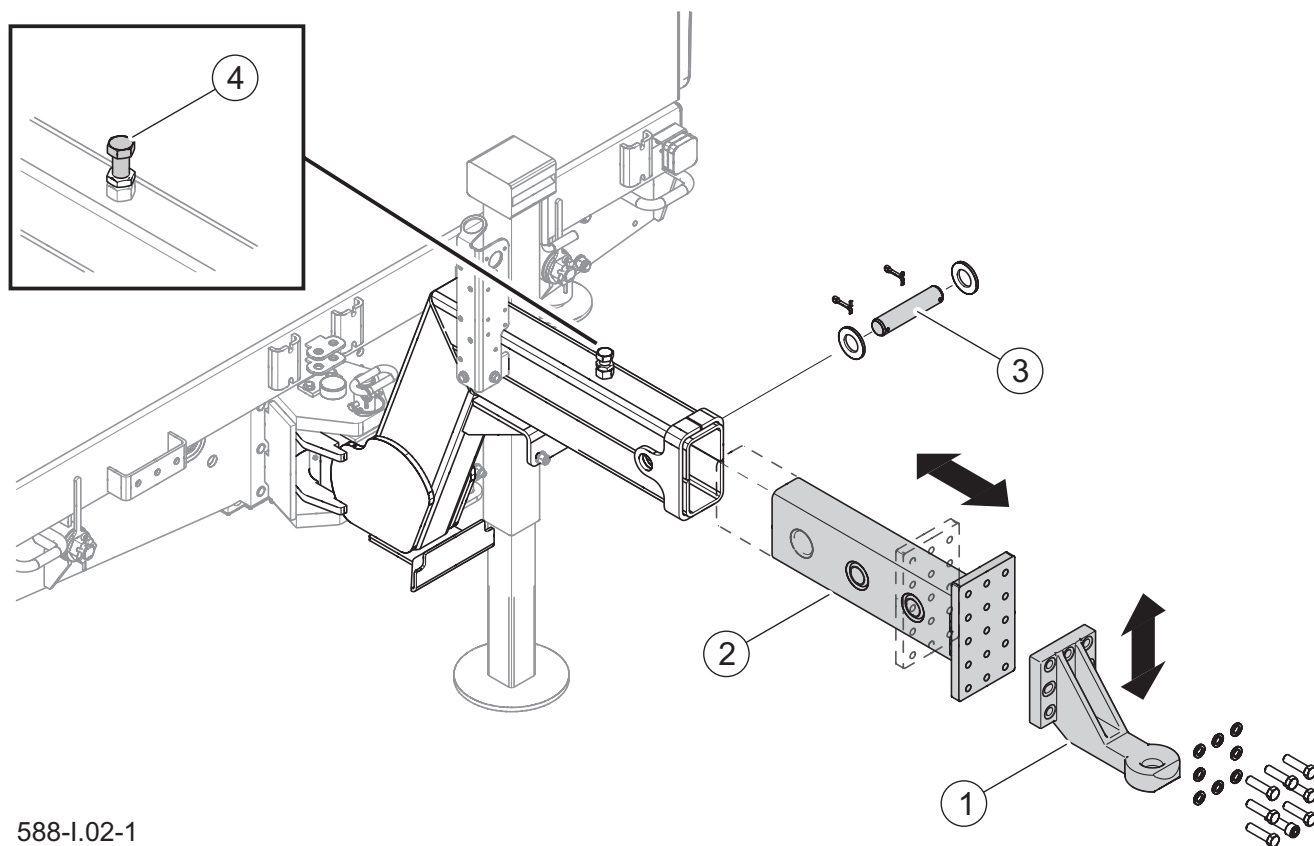

588-I.02-1

Figure 5.2 Adapt the machine to the upper hitch of the carrier vehicle
 (1) fixed drawbar eye (2) drawbar (3) pin (4) compression bolt

(Figure 5.2) additionally have the option to adjust the hitch length by 150 mm. In order to adjust the hitch length, loosen the clamping bolt (4), remove the pin (3), slide in or slide out the drawbar (2) and relock the drawbar with clamping bolt (4) and pin (3).

In order to adjust the height of sweeper drawbar (Figure 5.2), change the drawbar eye (1) fixing holes. By turning the drawbar eye, a greater range of adjustment can be obtained.

The fixed drawbar eye height (measured from the ground) can be adjusted within the range of 745 - 1055 mm, by steps of 55 mm. (Figure 5.2)



DANGER

When hitching, there must be nobody between the machine and the carrier vehicle. When hitching the machine, the tractor unit driver must exercise due caution and make sure that nobody is present in the hazard zone.

CONNECT THE MACHINE TO THE CARRIER VEHICLE HITCH

The machine can be connected to the carrier vehicle, if all the connections and the vehicle's hitch comply with the requirements of the machine manufacturer.

Ensure sufficient visibility during hitching.

In order to connect the sweeper with the carrier vehicle, perform the following steps:

- Using the adjustable support (Figure 5.3) set the drawbar eye at such a height that it is possible to connect

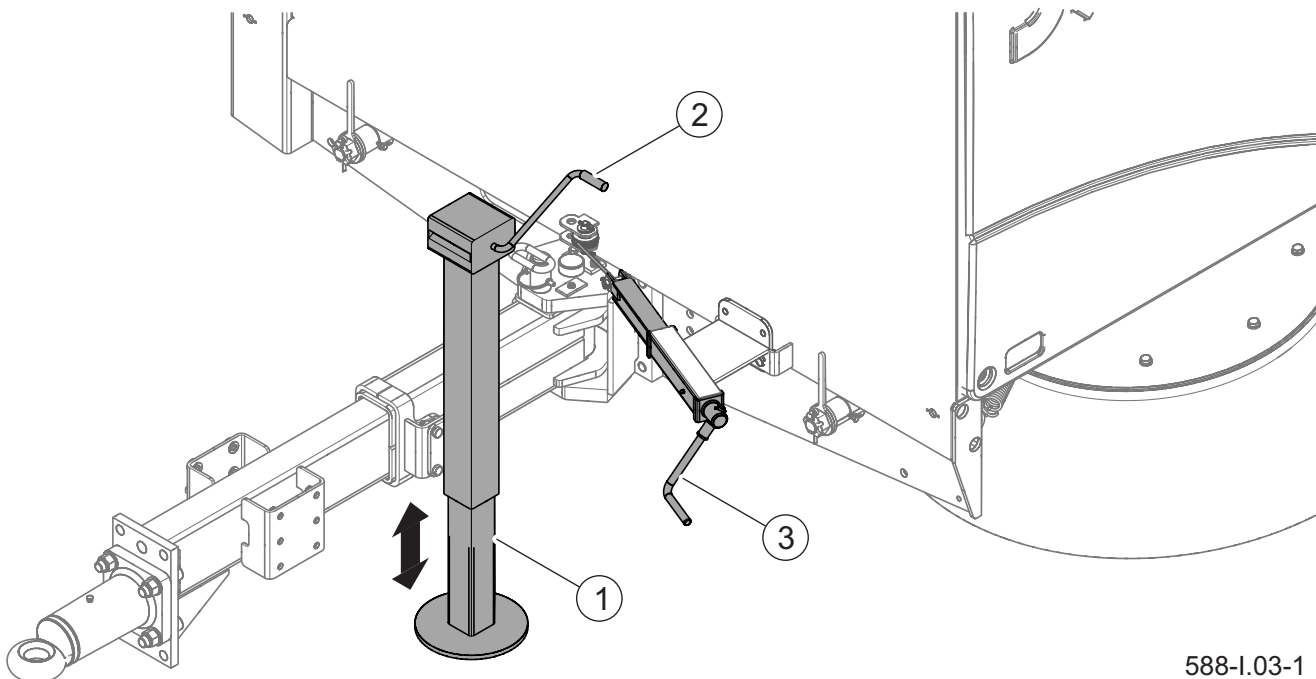

588-I.03-1

Figure 5.3 Parking stand and parking brake
 (1) parking stand (2) parking stand height adjustment crank
 (3) parking brake mechanism

the machines.

- While carrier vehicle is in reverse, connect drawbar eye to the hitch and check if the connection is secure.
- The carrier vehicle's engine is turned off Apply the parking brake. Ensure that unauthorised persons do not have access to the vehicle cab.
- Connect the PTO shaft and cables.
- Fully raise the parking stand and release the parking brake (Figure 5.3).



IMPORTANT

Parking stand must be maximally raised during machine operation and travel.

CONNECTING PTO SHAFT

The machine may only be connected to the carrier vehicle by means of a proper PTO shaft. Use PTO shaft recommended by the Manufacturer.

Connect the shaft to the machine as instructed by the shaft manufacturer. Secure the chains preventing the shaft cover from turning to a fixed structural element. After

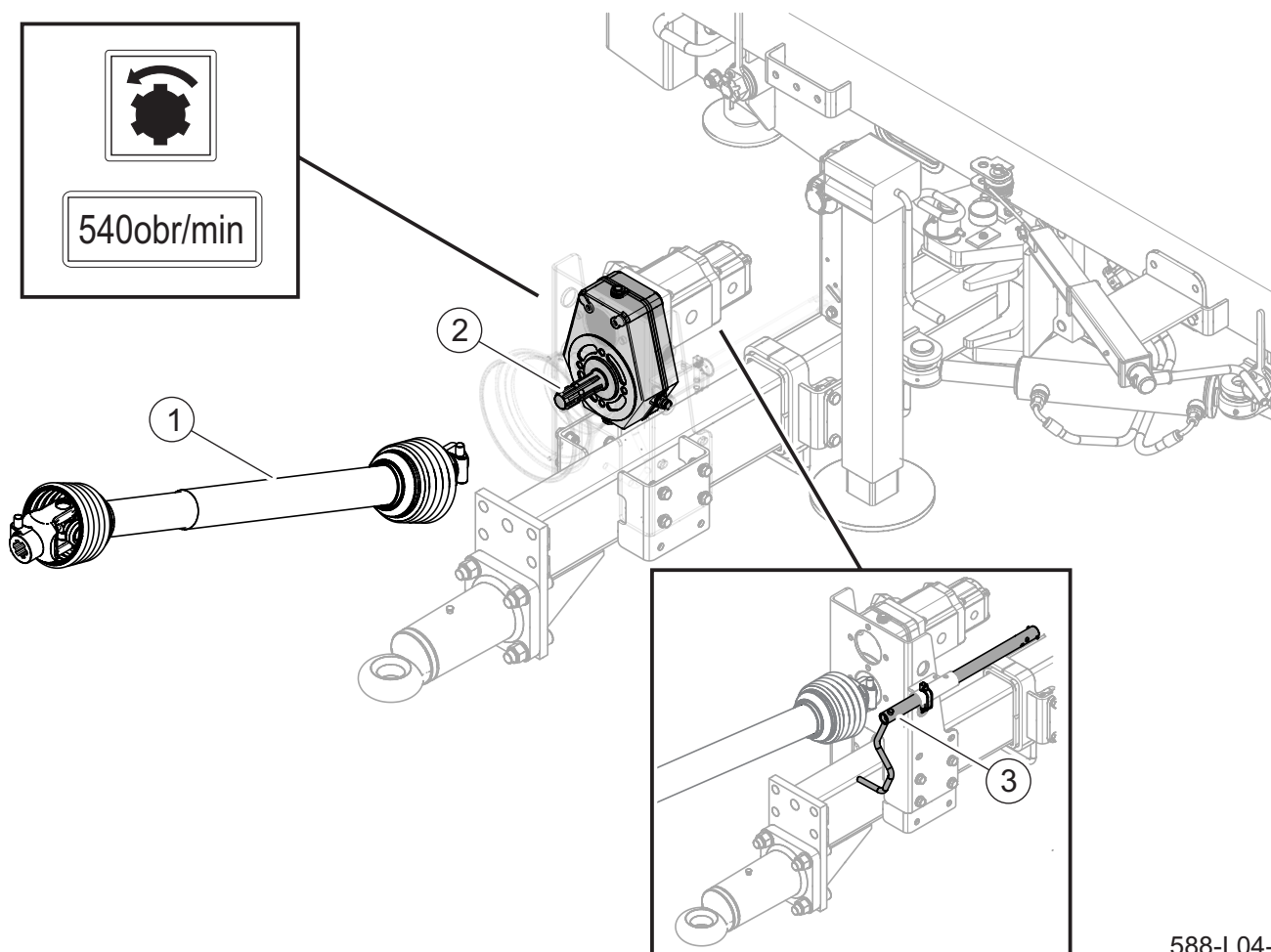

588-I.04-1

Figure 5.4 Connecting PTO shaft

(1) PTO shaft
position

(2) a multiplier gear box

(3) the shaft hanger in the working

**DANGER**

Before connecting PTO shaft, turn off the vehicle's engine and remove key from ignition. Ensure that unauthorised persons do not have access to the carrier vehicle cab.

TIP

The proper alignment of the PTO shaft of the implement carrier (tractor) with the shaft of the machine's drive system significantly extends the life of the drive shaft.

**IMPORTANT**

Before connecting the PTO shaft, the user should read the PTO shaft Operator Manual provided by the Manufacturer.

connecting the shaft to the machine, the hanger (3) should be folded for operation and secured with a cotter pin (Figure 5.4) In the sweeper adapted to be connected with the lower hitch of the carrier, you can adjust the height of the multiplier gear box position in relation to the drawbar in order to obtain the smallest possible working angles of the PTO.

Depending on the version, the sweeper can be equipped with a 2-line air brake, single line air brake (option) or a hydraulic brake (option).

Connections and connecting lines of the pneumatic braking system (Figure 5.5) are made of coloured plastic. The colours of

CONNECT THE BRAKE SYSTEM

Figure 5.5 Connect the brake system

(A) double-line system

(B) single-line system

(1) "yellow" connector

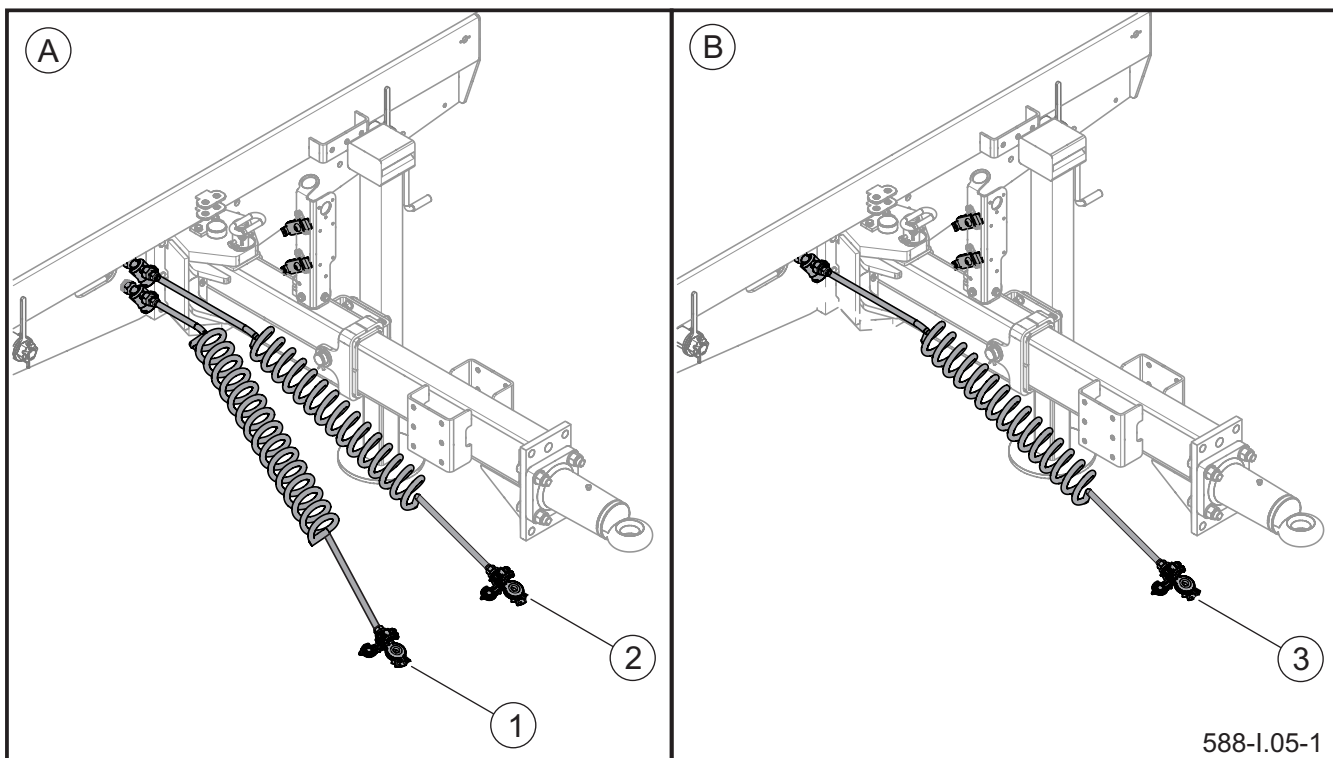
(2) "red" connector

(3) "black" connector



IMPORTANT

Before you connect the systems, carefully read the Operator Manual of the carrier vehicle and observe all manufacturer's recommendations

these elements correspond to the colours of the connection sockets in the carrier vehicle.

Reduce residual pressure in the system prior to connecting the hydraulic brake system (option).

CONNECT THE ELECTRICAL SYSTEM

Place the control panel (Figure 5.6) in the operator cab in an easily accessible place.

The panel can be attached to the windshield with the appropriate holder, which is included with the machine. Mount the holder to the glass in such a way that two of the three suction cups are at the top.

Connect the fused (6) red wire of the power cord to the positive vehicle battery

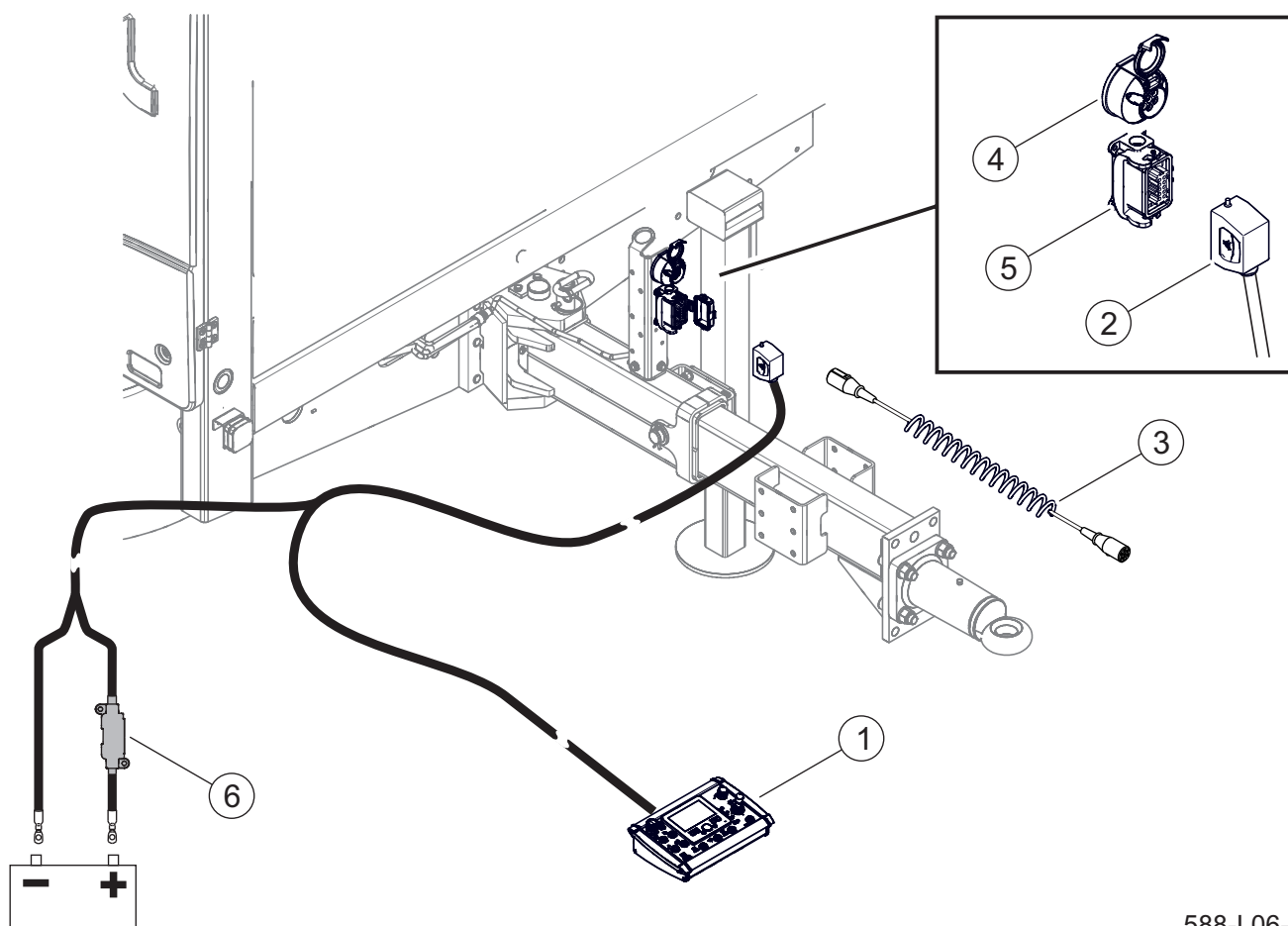

588-I.06-1

Figure 5.6 Connect the electrical system

- (1) control panel
- (4) 7-pin socket

- (2) control plug
- (5) control socket

- (3) connection cable
- (6) MIDIVAL 70A fuse

! IMPORTANT

Connection wires and lines should be routed in such a way that they do not get caught in the moving parts of the machine and the carrier and are not exposed to kinking or cutting during turning.

terminal (+) and black wire to the negative battery terminal (-). Connect plug (2) to socket (5) on the machine drawbar. The power harness has a MIDIVAL 70A fuse (6) located on the power wire.

Connect the road lighting system cable (3) to the 7-pin socket (4) on the machine drawbar and to the carrier vehicle. After

! DANGER

Do NOT travel with machine which has unreliable brake, lighting or signalling system.

connecting the cable to the control panel, turn on the power of the panel and check the operation of the road lighting.

DRAWBAR SWIVEL LOCK

Before starting work with the sweeper, make sure that the drawbar turning interlock is unlocked (B) (Figure 5.7). Lock pin (1) should be secured with a cotter pin (2) in the upper hole (A). Drawbar turning

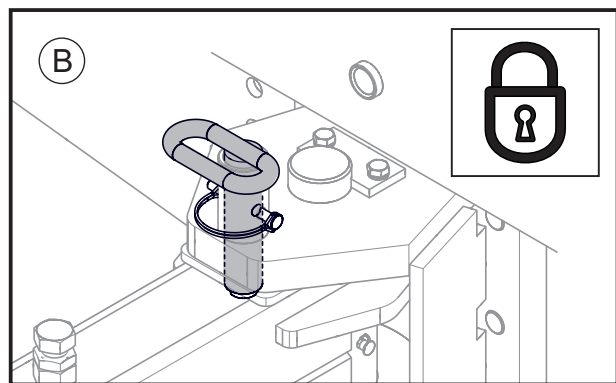
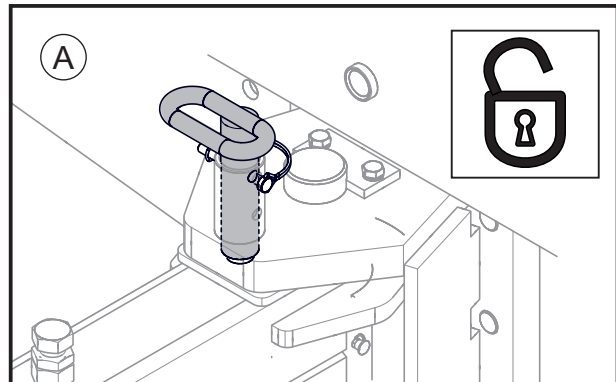
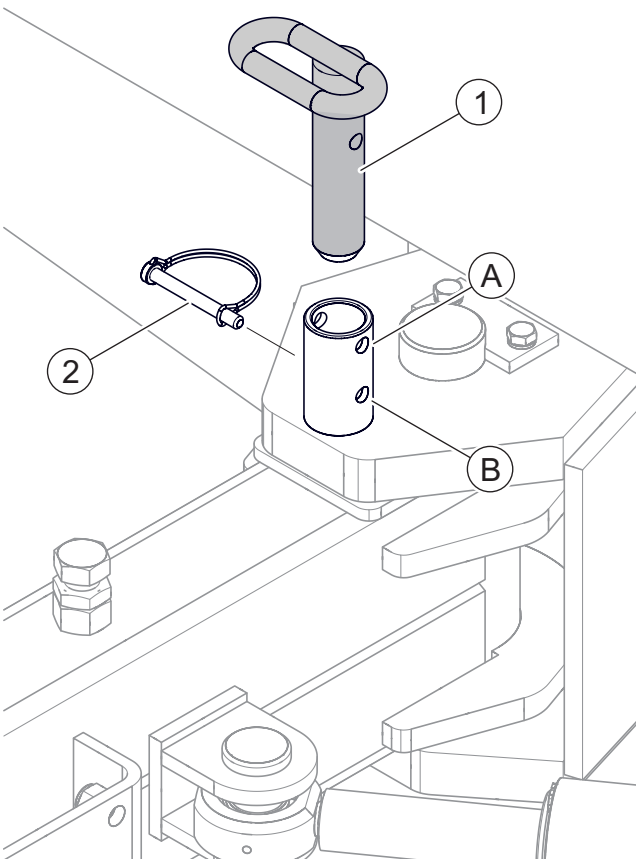

588-I.07-1

Figure 5.7 Drawbar swivel lock
 (1) lock pin (2) cotter pin
 (A) drawbar unlocked (B) drawbar locked

interlock (B) is used during transport or when the machine is parked.

**IMPORTANT**

While operating the sweeper, the drawbar swivel lock should be unlocked.

I.2.6.588.03.1.EN

5.4 SWEEPER OPERATION

FILL THE WATER TANK

The sweeper is equipped with two inter-connected water tanks. You can fill water tanks (1) of the spray system through one



IMPORTANT

If there is a risk that temperatures drop below 0°C, drain water from the tank, conduits, filter and pump.

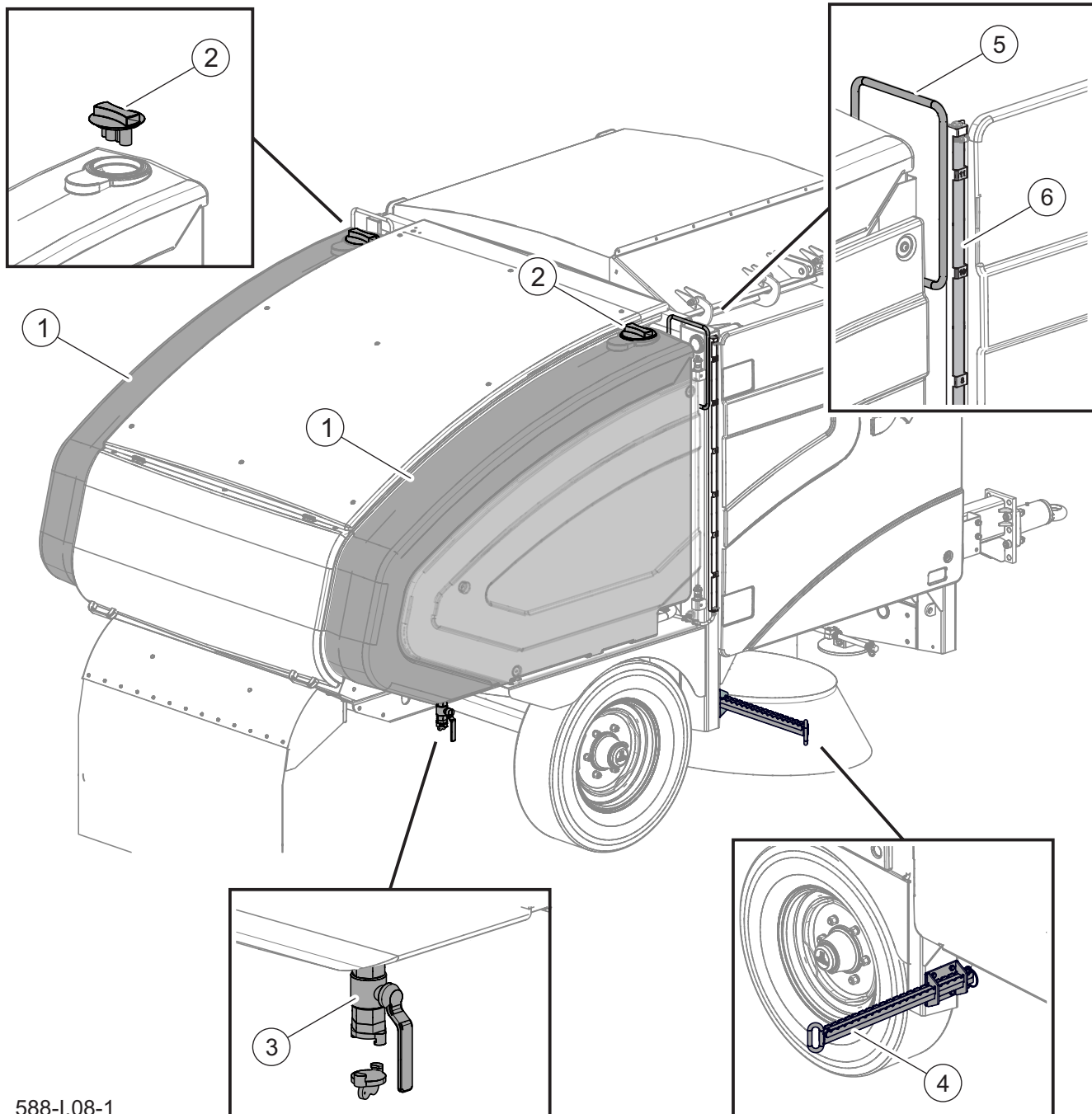

588-I.08-1

Figure 5.8 Fill the water tanks

(1) water tank
(4) foot

(2) filler plug
(5) bracket

(3) claw coupling with valve
(6) water gauge

of the filling openings secured with plugs (2) located in the upper part of the water tank (FIGURE 5.8) or from the water supply pipe using a claw coupling with a valve (3). The valve (3) is also used to drain the tanks. There is an extendable step (4) and a handle (5) to facilitate access to the filler plug. During machine operation, check the water level in the tank using a water gauge (6). If there is no water in the tank, turn off the spray system.

STARTING THE MACHINE

To start the sweeper:

- Turn on the control panel using the switch (1) located on the back of the panel (Figure 5.9).

After software start-up, the operator screen will be displayed on the LCD.

- Start the power take-off (PTO) drive in the carrier vehicle and set the appropriate rotation speed.

Yellow icon (2) on the LCD indicates that the PTO drive is

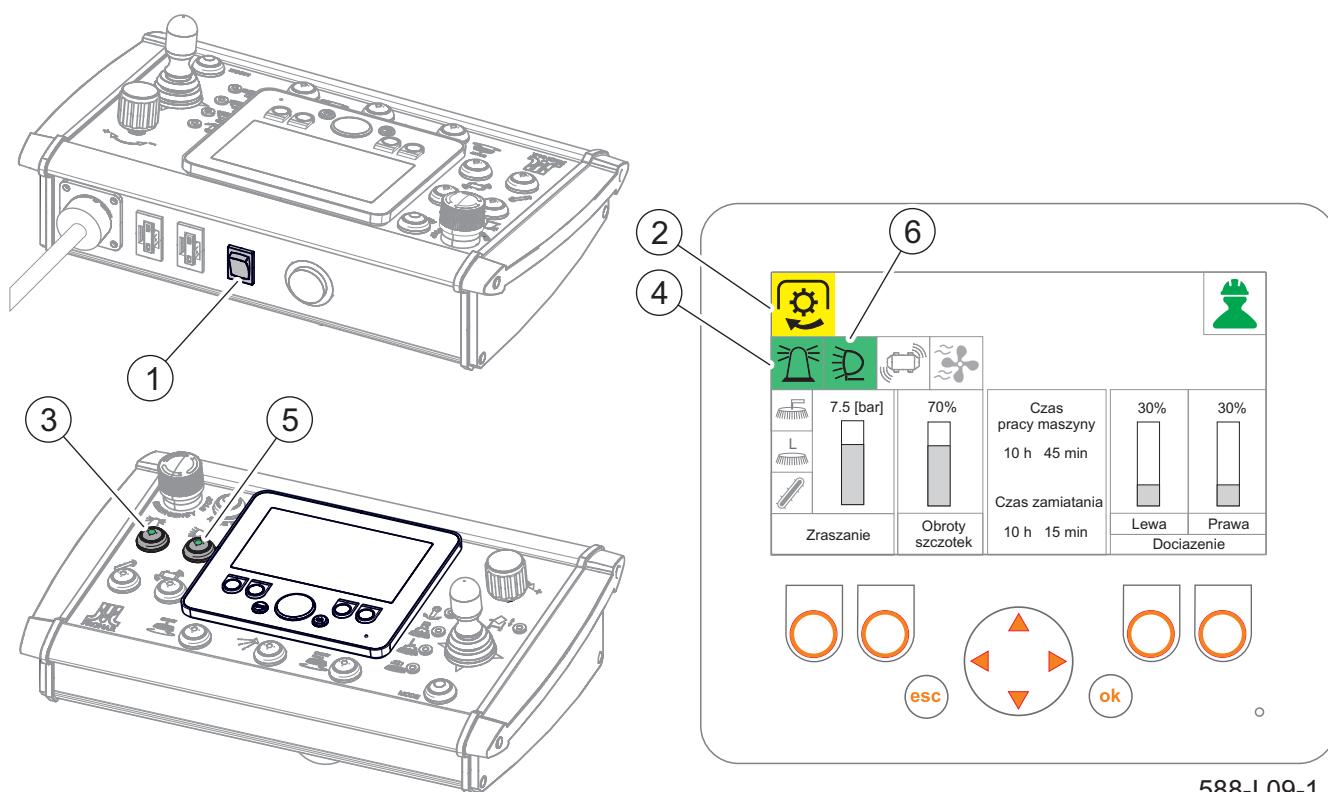

588-I.09-1

Figure 5.9 Starting the machine

- (1) control panel switch (2) active hydraulic drive icon (3) warning light switch
 (4) warning light operate icon (5) work area lighting switch (option)
 (6) work area lighting on icon

detected.

- Turn on the warning light with the button (3) on the control panel (Figure 5.9).

The button (3) on the control panel and the icon (4) on the LCD will be highlighted in green.

- If necessary, turn on the work area lighting (option) using the button (5) on the control panel.

Light illuminating the rotary disc brushes will be turned on. The icon (6) on the LCD screen and the button (5) on the operator panel will be highlighted in green.

SWEEPING

To start sweeping:

- Press the button (1) on the control panel (Figure 5.10). The roller brush, conveyor and rotary disc brushes drive will be activated.

When you switch on sweeping, the button (1) will be highlighted in green. The icon (2) will appear on the LCD screen.

- If necessary, start the side brush (option) with the button (3).

See side brush control (option)

- To raise the sweeping unit while the machine is operating, press the

DANGER

Before engaging PTO drive, make sure that there are no bystanders, especially children, near the machine.

IMPORTANT

Reversing the sweeper with brushes lowered is prohibited.

TIP

Sweeping cannot be started if the conveyor is in reverse mode, the pressure washer (optional) is operating or the waste container is raised.

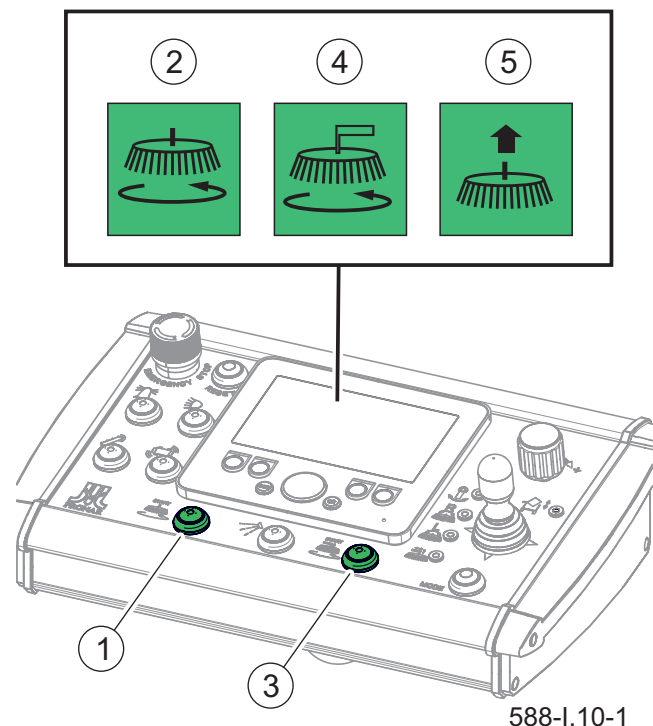

Figure 5.10 Sweeping
 (1) sweep on switch
 (2) sweep on icon
 (3) side brush on button (option)
 (4) side brush on icon
 (5) sweeping unit raise icon

sweeping switch (1) and hold it for 3 seconds (Figure 5.10)

Raising the sweeping mechanism is indicated by the icon (5) on the LCD.

**DANGER**

During machine operation do not occupy a different position than that of the operator in the tractor cab. Do NOT leave the cab, when the machine is in operation.

Do NOT stay between the carrier and the machine. The operator must NOT approach the machine until the rotating components come to a full stop.

TIP

Depending on degree of contamination of surface, adjust ground speed during sweeping and set proper rotation speed of brushes.

Reduce ground speed if amount of contaminants to be swept increases.

Adjust pressure of brushes to force of adhesion of contaminants to the surface cleaned.

SPRAYING

In the event of heavy dust, turn on the spray system with the button (1) on the control panel. (Figure 5.11)

The activation of the spray system is indicated by the icon (2) on the LCD and the illumination of the button (1) on the control panel.

The conveyor and left disc brush spray system can be independently turned on or off. In the basic version (see Figure 5.12) this is done with water valves located under the machine right cover (Figure 5.12).

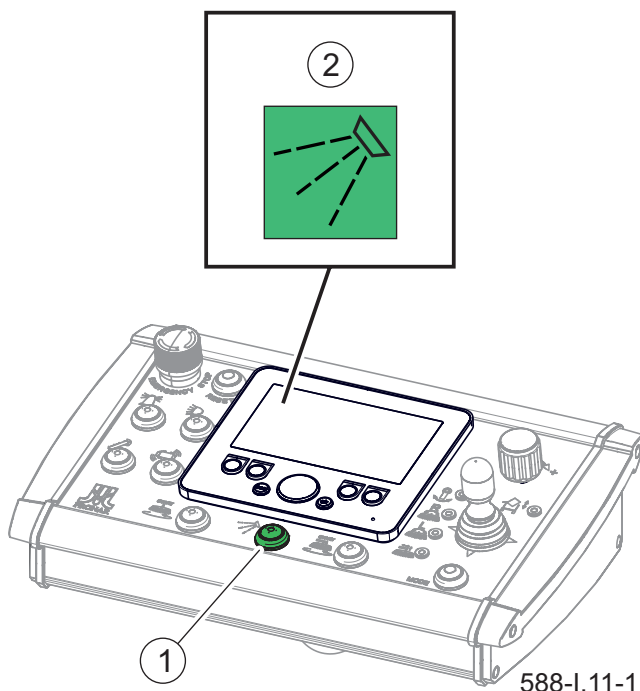
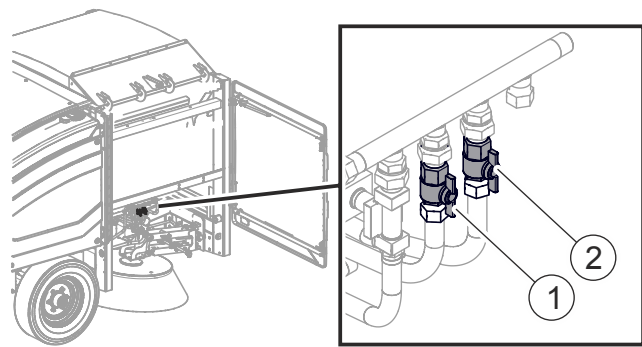

Figure 5.11 Turn on spray
(1) spray on / off switch
(2) spray on icon



588-I.22-1

Figure 5.12 Spray valves

(1) left brush spray valve
(2) conveyor spray valve

TIP

Spraying can only be started when sweeping is turned on.

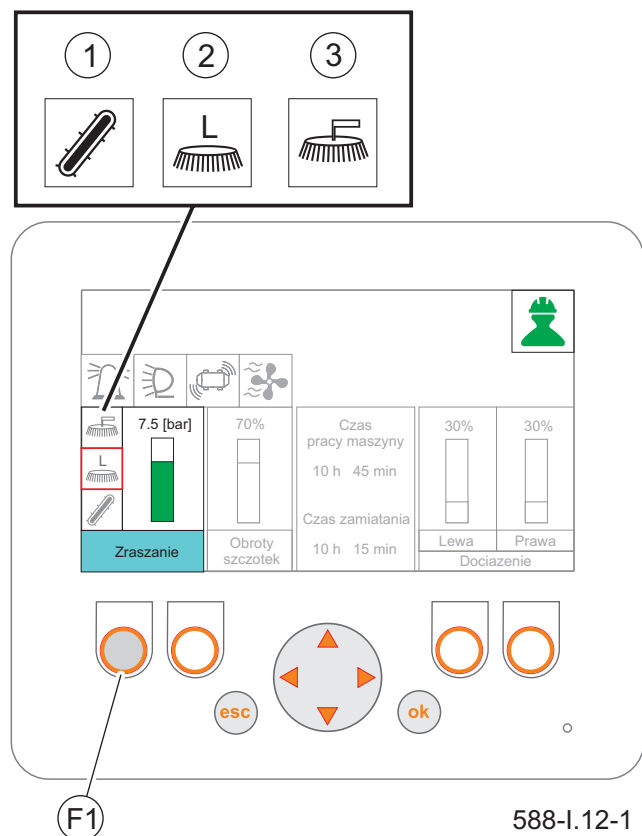

588-I.12-1

Figure 5.13 Spray control (option)

(F1) spray control function button (1) conveyor spray (option)

(2) left rotary disc brush spray (option)

(3) side brush spray (optional)

In the optional version spraying is controlled electrically (Figure 5.13):

- conveyor spray,
- left disc brush spray,
- side brush spray,
- water pressure adjustment (Figure 5.14).

The individual spray nozzles are turned on the operator LCD. Use the (F1) button to select the SPRAY indicator and then use the arrow keys to highlight the appropriate icons next to the spraying indicator and confirm with the OK button.

White icons on the LCD panel indicate the activation of individual spray circuits.

To turn off the spray system completely, press the button (1) on the control panel (Figure 5.11).

The water pressure (option) is controlled on the operator panel (Figure 5.14). After selecting the SPRAY indicator with the function button (F1), you can change the pressure value using the up / down arrow key or the knob (2) on the control panel.

To turn off the spray system completely, press the button (1) on the control panel (Figure 5.11).

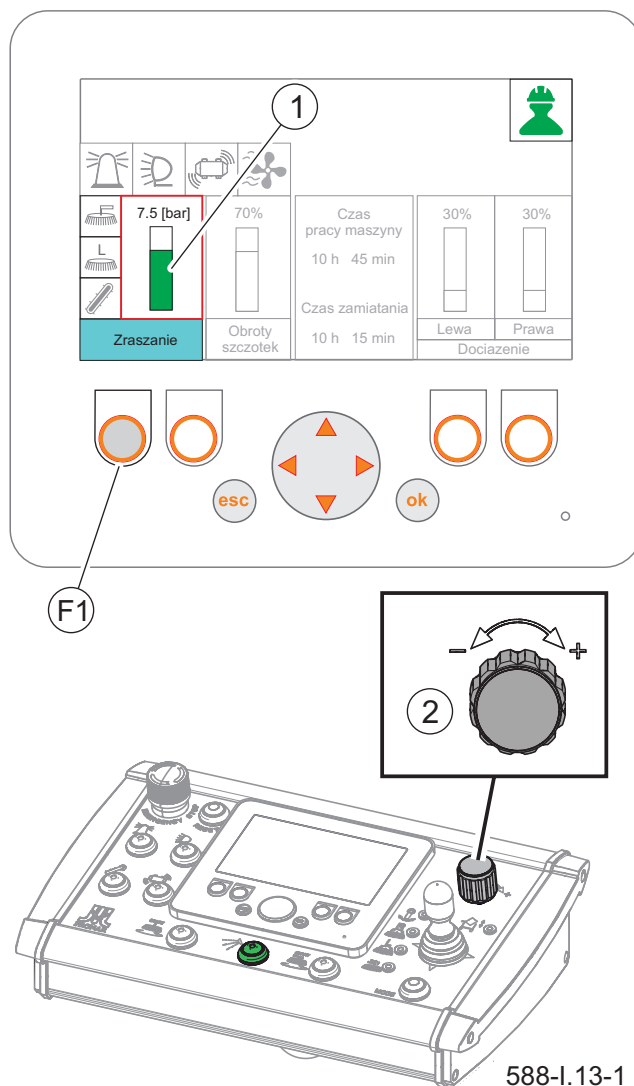

Figure 5.14 Adjust water pressure (option)
 (F1) spray control function button
 (1) spray pressure indicator
 (2) settings adjust knob

TIP

Adjust water pressure only when the spraying is turned on, otherwise the correct pressure value will not be displayed.

ADJUST BRUSH SPEED

The rotational speed of both rotary disc brushes can be adjusted simultaneously. You can adjust the rotational speed of disc brushes on the LCD panel operator screen, when you select the BRUSH ROTATION indicator with the F2 function button. Make the adjustment using the up / down arrow key or the knob (2) on the control panel.

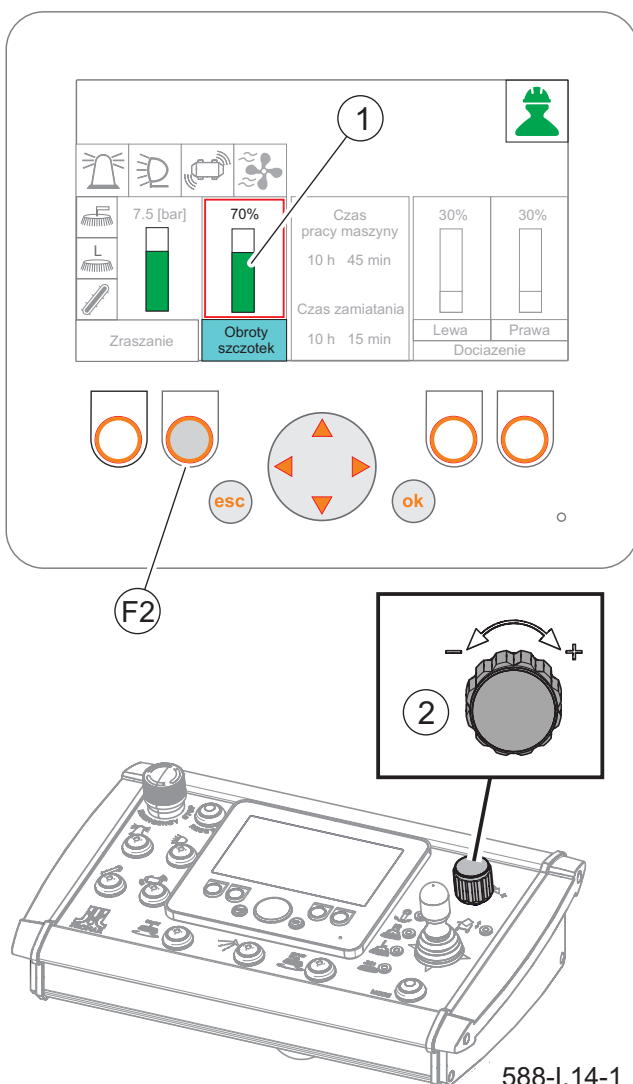

Figure 5.15 Adjust the brush rotation speed
(F2) spray control function button
(1) brush rotation indicator
(2) settings adjust knob

Increasing the number on the indicator increases the rotational speed.

ROTARY DISC BRUSH TILT

You can adjust the right brush and left brush (option) lateral tilt on control panel in operator cab. Figure 5.16)

To adjust the right disc brush tilt:

- Press the MODE button (2) to switch the multi-function lever (1) to the control of the right disc brush.

The selected function is indicated by indicator (3).

- To tilt the right brush to the right, push the multi-function lever (1) to the right.

The brush movement is indicated by icon (5) on the LCD.

- To tilt the right brush to the left, push the multi-function lever (1) to the left.

The brush movement is indicated by icon (6) on the LCD.

When tilting the left hydraulically adjustable brush (option), use the MODE button (2) to switch the multifunction lever (1) to control the left disc brush.

The selected function is indicated by indicator (4).

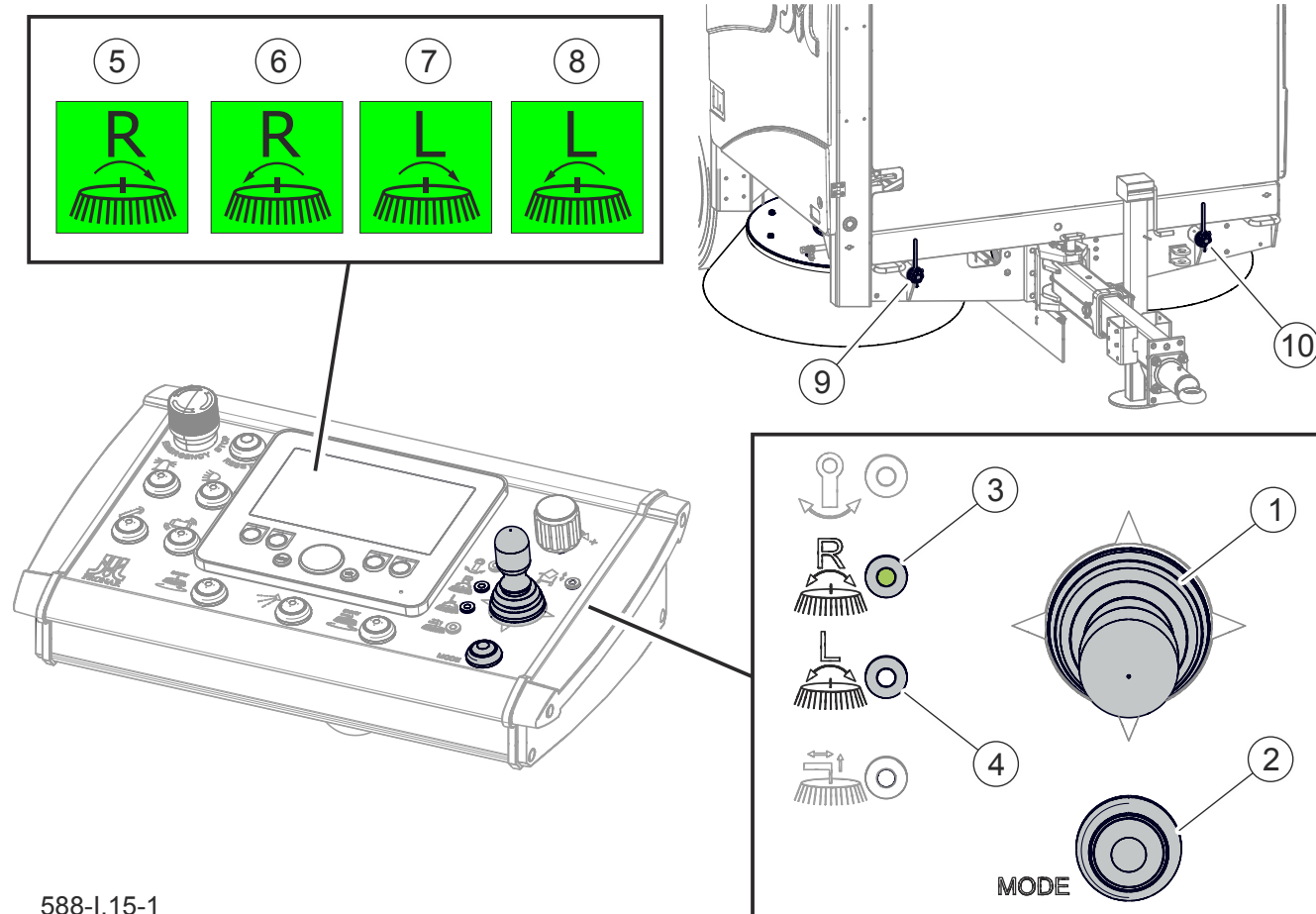

588-I.15-1

Figure 5.16 Tilt rotary disc brushes

- (1) multifunction lever
- (2) Multi-function lever mode button
- (3) Right brush tilt control function select light
- (4) Left brush tilt control function select light
- (5) right brush tilt right icon
- (6) right brush tilt left icon
- (7) left brush tilt right icon
- (8) left brush tilt left icon
- (9) right brush tilt indicator
- (10) left brush tilt indicator

The control method is the same as for the right brush.

Indicators (9) and (10) on the front section of the machine frame show the current transverse tilt of the brushes. (Figure 5.16).

SIDE BRUSH CONTROL (OPTION)

In the sweeper, optionally equipped with a retractable side brush (Figure 5.17), you can control the brush operation using the control panel as follows:

- Start the sweeping (see *SWEEPING*)
- Press the (4) button on the control panel to start and lower the side brush to the working position.

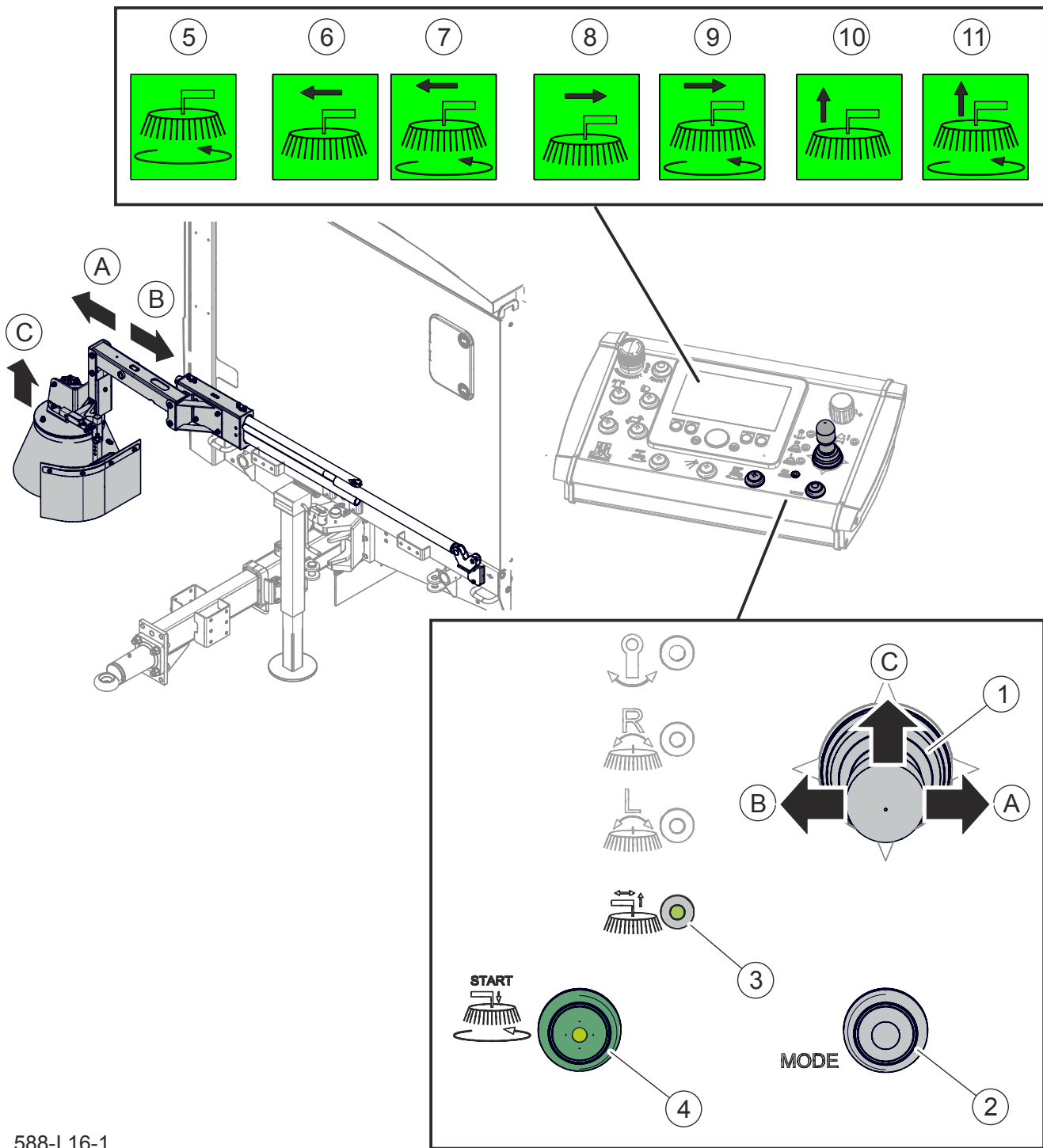

588-I.16-1

Figure 5.17 Side brush control (option)

- (1) multifunction lever
- (2) Multi-function lever mode button
- (3) Side brush control function select indicator light
- (4) brush lower and sweep on buttons
- (5) sweep on icon
- (6) brush arm extend icon
- (7) brush arm extend icon - sweeping
- (8) side brush retract icon
- (9) brush arm retract icon - sweeping
- (10) brush raise icon
- (11) brush raise icon - sweeping
- (A) brush arm extend
- (B) brush arm retract
- (C) raise brush

The multi-function lever (1) will be in side brush control mode and the indicator (3) on the panel will light up. The icon (5) will appear on the LCD screen.

Use the multi-function lever (1) to control the side brush arm (Figure 5.17).

Side brush movement is indicated by an icon (6-11) on the LCD.

When the side brush is raised while sweeping and then the multi-function lever is released, the brush is automatically lowered to the working position.

When sweeping is off, raise the side broom to transport position by shifting the multifunction lever (1) to position (C). The brush will remain in the raised position.

While sweeping with the side brush, you can use the (2) MODE button to select other control modes of the multifunction lever (e.g. drawbar control, tilting the rotary disc brush).

CONVEYOR AND ROLLER BRUSH REVERSE MOTION

Reverse motion of the conveyor and roller brush is activated by pressing and holding the button (1) on the operator panel (Figure 5.18).

Reverse motion of the conveyor is indicated by the icon (2) on

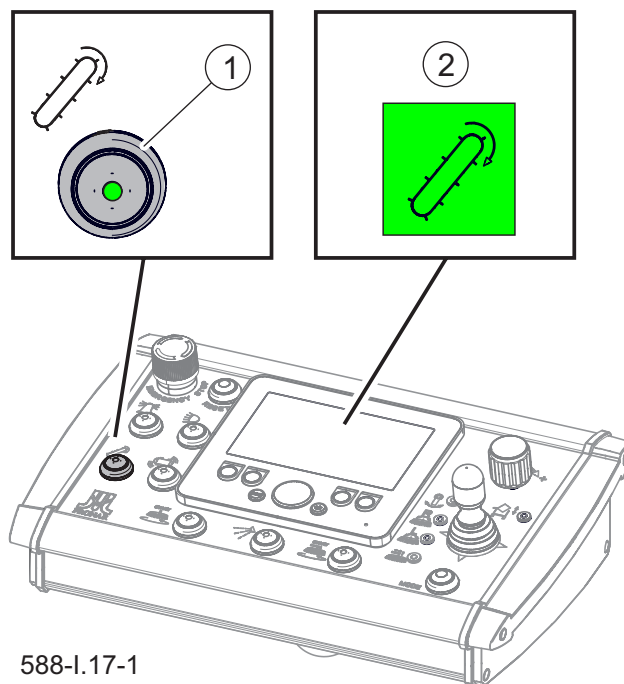

588-I.17-1

Figure 5.18 Conveyor and roller brush reverse motion

(1) conveyor and roller brush reverse motion on button (2) reverse motion icon

the LCD and the backlight of the button (1) on the control panel (Figure 5.18).

The reverse will not work if the sweeping, lifting, pressure washer is on or the waste container is being unloaded.

SWIVEL DRAWBAR CONTROL

TIP

Conveyor reverse motion does not work while sweeping, raising, and pressure washer is on, or the waste container is being emptied.

In order to enable the control of the sweeper tilting drawbar, the drawbar must be unlocked.

see DRAWBAR SWIVEL LOCK

Switch the multi-function lever (1) mode to sweeper swivel drawbar control (Figure 4.19) by pressing the (2) MODE button on the control panel until the indicator (3) lights up. By tilting the lever (1) to the right / left, tilt the drawbar in the required direction. The drawbar tilt is indicated by the icon (4), (5) on the LCD (Figure 5.19).

The drawbar is set in tilted position if sweeping has to be done near building walls, kerbs, etc. Thanks to such hitch position, the sweeper path can be shifted to the right with regard to the vehicle's path. Thanks to adjustable sweeper tilting drawbar, the sweeper can accurately

follow the vehicle, particularly when sweeping on turns, around columns, posts and benches.

EMPTY THE WASTE CONTAINER

The sweeper enables unloading directly onto the trailer load box or onto a stock pile. The waste container can be emptied only after the carrier has completely stopped (the PTO drive must be engaged)

To empty the waste container (Figure 5.20):

- Place the sweeper in the unloading area on a stable and flat surface.
- Press the MODE button (2) on the control panel for 3 seconds to switch the multi-function lever (1) to the

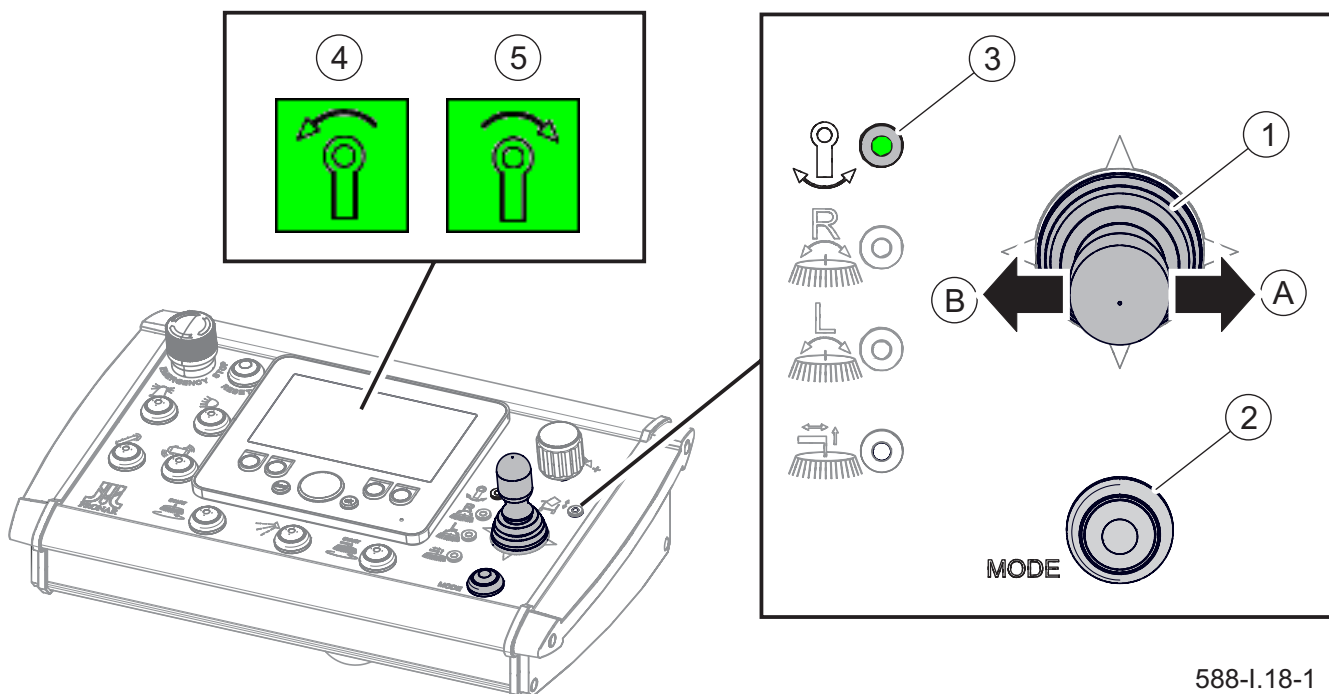

588-I.18-1

Figure 5.19 Swivel drawbar control

- (1) multifunction lever (2) Multi-function lever mode button
 (3) drawbar swivel control function indicator (4) drawbar swivel left icon
 (5) drawbar swivel right icon (A) drawbar swivel right (B) drawbar swivel left

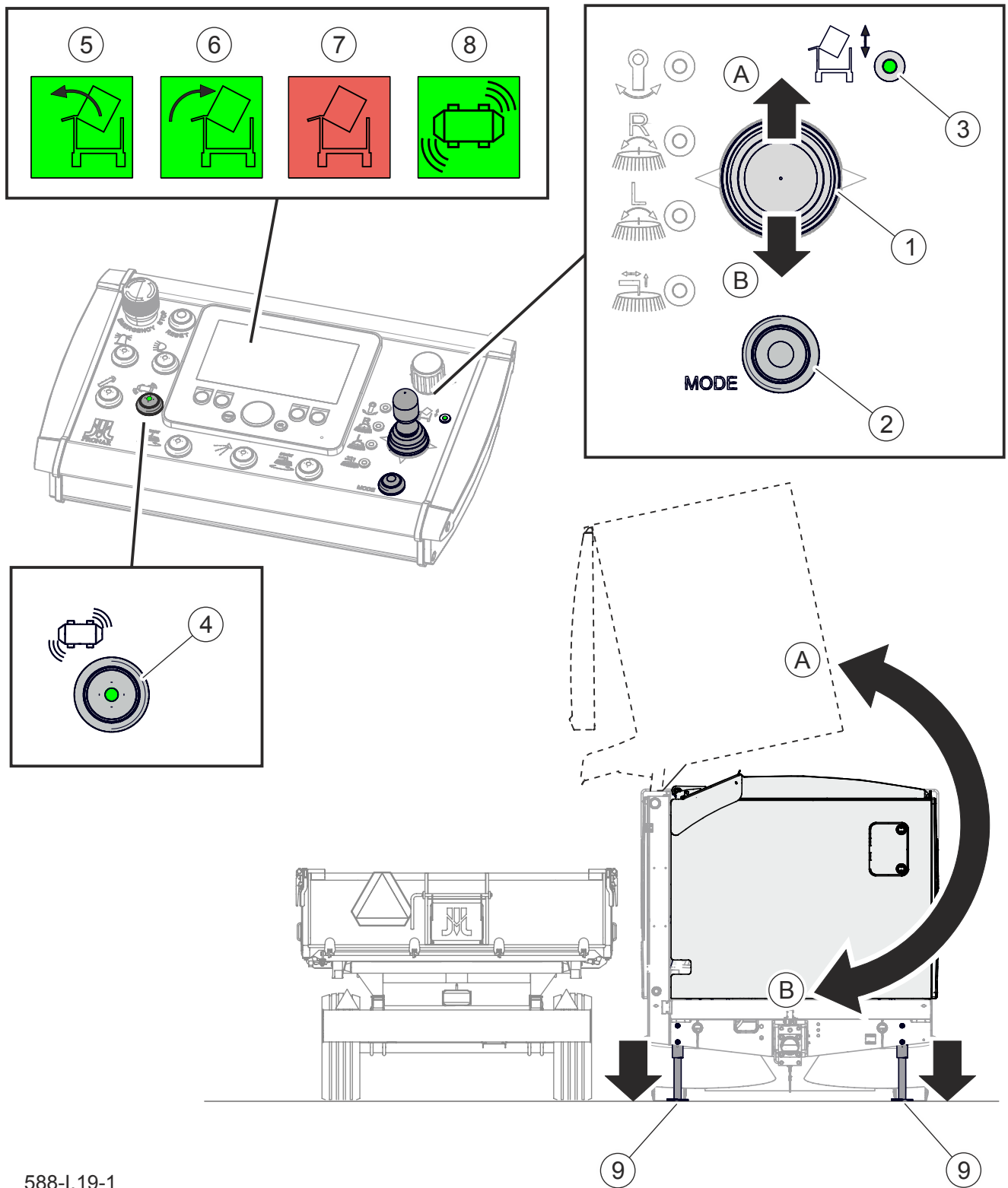

588-I.19-1

Figure 5.20 Empty the waste container

- (1) multifunction lever
- (2) Multi-function lever mode button
- (3) tank control function indicator
- (4) vibrator activate button
- (5) tank raise icon
- (6) tank lower icon
- (7) tank raised warning icon
- (8) vibrator on icon
- (9) hydraulic support
- (A) raise the tank
- (B) lower the tank

waste container discharge control.

An indicator (3) next to the multi-function lever on the control panel will illuminate.

- Move the multi-function lever (1) to position (A) and keep it pressed until the waste container is fully raised.

Raising the tank is indicated by the icon (5) on the LCD and a beep.

While unloading the waste container (Figure 5.20), hydraulic supports (10) are lowered and warning beep is sounded.

In order to facilitate discharging waste from the tank, the vibrator (option) can be activated by means of (4) button on the control panel.

After unloading waste, switch the vibrator off.

You can use the pressure washer (optional) supplied with the machine to clean the waste container.

see PRESSURE WASHER

To lower the waste container (Figure 5.20) to the working position, shift the multi-function lever (1) to position (B) and hold it until the waste container is completely lowered and the hydraulic supports (9) are raised.

Lowering the tank is indicated by the icon (5) on the LCD and a beep.



IMPORTANT

After completing the unloading and lowering the waste container, make sure that the hydraulic supports have been raised.

Until the waste container is completely lowered, the warning icon (7) will appear on the display.

PRESSURE WASHER (OPTION)

The pressure washer (Figure 5.21) is disabled by default and must be activated in the SETTINGS SCREEN display menu before use.

see LCD PANEL MENU

When you activate the pressure washer, the display will show the white icon (3) and the button (2) on the washer support (Figure 5.21) will start flashing yellow - the washer is ready to use.

To remove the washer lance from the housing, unlock the fastening clasp. By pulling the pressure washer line, unwind it from the drum to the required length.

The washer hose drum locks automatically in the desired position.

To start washing:

- Press the button (2) on the washer drum support.

The button will illuminate green.

- Direct the washer lance in the desired direction and press the trigger on the lance handle.

The pressure washer operation is indicated by the green icon (3) on the LCD and the pressure washer button (2) is illuminated green.

TIP
The washer cannot operate during sweeping, reverse conveyor operation, raising and when the water level in the tank is low.

! DANGER
The pressure washer works under high pressure. Danger of body injury. Do NOT direct the water jet towards bystanders and live electrical devices

! IMPORTANT
When you activate the washer on with the button (2) and do not use the lance, the washer pump can operate for no longer than 3 minutes. Otherwise, the water pump may overheat.

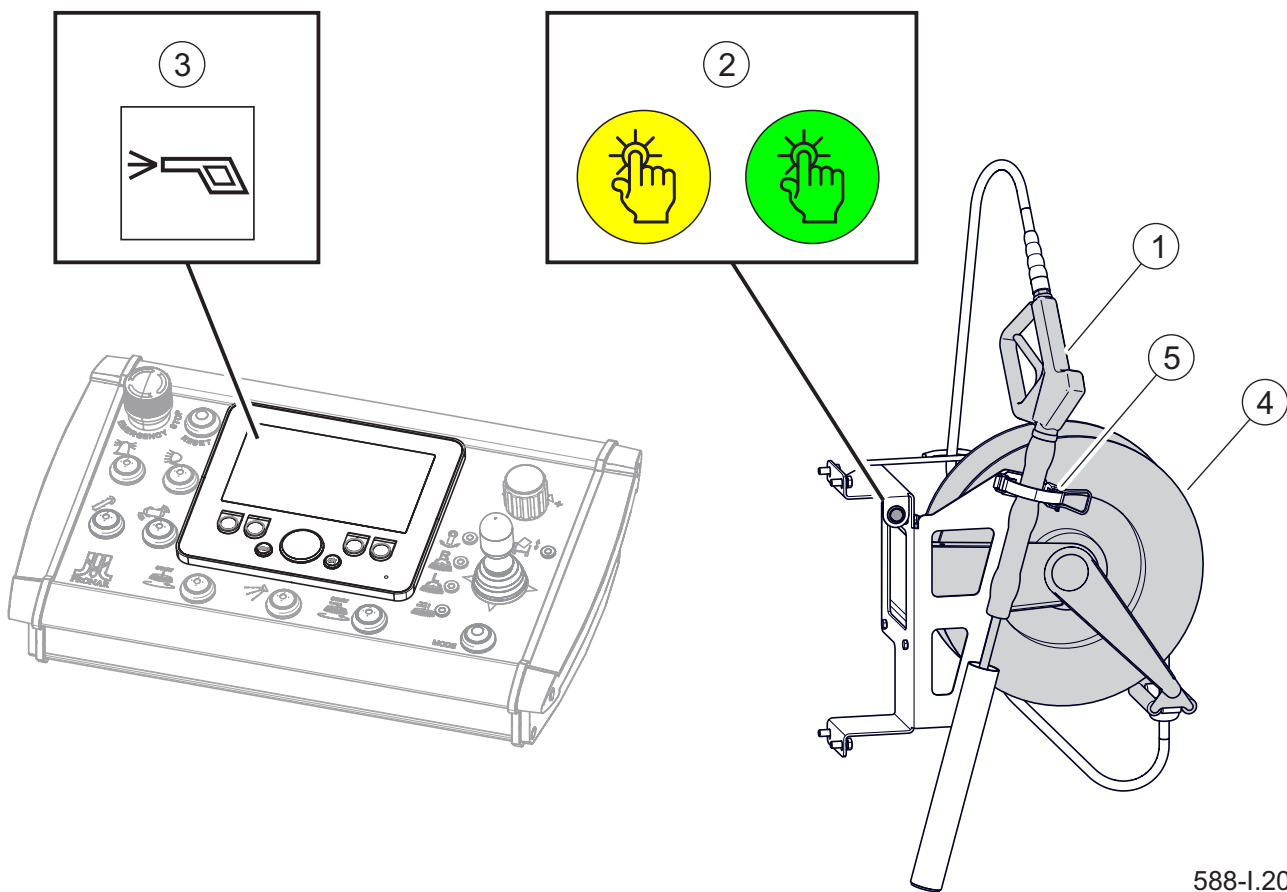

588-I.20-1

Figure 5.21 Pressure washer

- (1) lance
- (2) washer switch - illuminated in yellow and green
- (3) active washer icon - white
- (4) line drum
- (5) fastening clasp

WORKING WITH A TELESCOPIC PTO SHAFT

When aggregating the machine with a tractor and during operation, the user should be aware of the risks and dependencies presented below and is obliged to follow the rules given.

Too large or unequal angles of connection of the telescopic articulated shaft with the carrier and the machine (different on two crosses) cause increased noise and vibrations, which in turn may lead to damage to the shaft or the machine.

Recommendations:

1. Adjust the tractor hitch length (if possible).
2. Set the carrier PTO and the machine PTO to the same height as possible (if possible).
3. Avoiding sharp turns when operating the machine. Reduce the PTO speed when maneuvering around curves. Disengage



IMPORTANT

The permissible operating angle of a shaft with single joints is (for SIPMA, WEASLER shafts):

25° – for continuous operation

45° – for intermittent operation

Note: Shafts from other manufacturers may have different recommended operating angles, which are specified in the operating instructions included with the shaft.

TIP

In trailed machines, different working angles of the two crosses result from different (not equal) distances between the drawbar eye and PTO of the carrier and the drawbar eye and PTO of the machine.

the PTO drive when turning.

4. Disengage the PTO drive whenever power is not required or when the tractor and machine are at an unfavorable angle to each other.

Following the above guidelines will significantly extend the life of the PTO shaft and the machine's drive system.

I.2.6.588.05.1.EN

5.5 DRIVING ON PUBLIC ROADS

When driving on public roads, respect the road traffic regulations, exercise caution and prudence. If sweeping with the sweeper is done near pavements special attention should be paid to the bystanders likely to be near the working machine. Listed below are the key guidelines for driving the tractor and trailer combination.

- Make sure that the sweeper is correctly attached to the vehicle and the hitch is properly secured.
- Before moving off make sure that there are no bystanders, especially children, near the machine. Ensure that the driver has sufficient visibility.
- Do not exceed the design speed and maximum speed allowed by road traffic regulations. The towing speed should be adapted to the current road conditions, load carried by the machine, road surface conditions and other relevant conditions.
- While operating the sweeper, turn the orange beacon light (included in the machine equipment).
- Avoid ruts, depressions, ditches or driving on roadside slopes. Driving across such obstacles could cause the machine and the carrier vehicle to suddenly tilt. Driving near ditches or canals is dangerous as there is a risk of the wheels sliding down the slope or the slope collapsing.
- During transport, the sweeper tilting drawbar should be set straight and locked in this position.
- When driving, avoid sharp turns especially on slopes.
- Please note that the braking distance of tractor and sweeper combination is substantially increased at higher speeds and loads carried in the sweeper.
- Speed must be sufficiently reduced before making a turn or driving on an uneven road or a slope.
- Lower the waste container after emptying. Do NOT drive with raised waste container and extended supports.
- When not connected to the carrier vehicle, the sweeper must be immobilised using parking brake and possibly also with chocks or other objects without sharp edges placed under the front and back wheels. Do NOT leave unsecured machine. In the event of machine malfunction, pull over on the hard shoulder avoiding any risk to other road users and position reflective warning triangle according to

traffic regulations.

- While driving on public roads the sweeper must be fitted with a certified or authorised reflective warning triangle. When driving, comply with all road traffic regulations, indicate an intention to turn using indicator lamps, keep all road lights and indicator lights clean at all times and ensure they are in good condition. Any damaged or lost lamps or indicator lights must be immediately repaired or replaced.

- Reversing the sweeper with brushes lowered is prohibited.

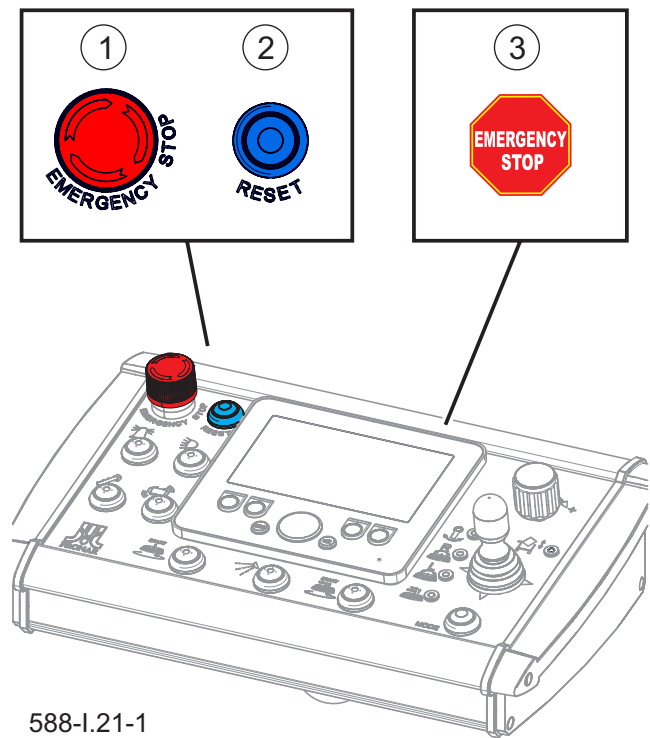

588-I.21-1

Figure 5.22 Emergency stop
(1) emergency stop button (red)
(2) RESET button (blue)
(2) EMERGENCY STOP icon (red)

I.2.6.588.05.1.EN

5.6 STOP THE MACHINE - EMERGENCY MODE

The machine may be stopped in emergency mode only if life or health of persons near the machine is endangered or there is a risk of serious damage.

Otherwise, stop the machine in correct sequence, turning off individual systems on the control panel.

To stop the machine in emergency mode (Figure 5.22) , press the red *EMERGENCY STOP* button (1) on the control panel as far as it will go. The button will remain pressed.

Emergency mode is indicated by the (3) EMERGENCY STOP icon and a beep.

To disable emergency mode, turn the emergency stop button (1) clockwise and then press the RESET button (2) on the control panel.

Before restarting the machine, make sure that its operation does not pose a threat to bystanders and that possible problems have been eliminated.

I.2.6.588.06.1.EN

5.7 AUDIBLE ALARM

An alarm siren installed in the sweeper generates audible alarm in the following cases:

- The waste container is being emptied or lowered.

Intermittent beep every second.

- Tank low water level warning.

3 short beeps.

The buzzer in the control panel generates an acoustic signal when:

- An alarm has been detected.
- A warning has been detected.
- EMERGENCY STOP pressed.

3 short beeps.

I.2.6.588.07.1.EN

5.8 UNHITCH THE MACHINE FROM THE CARRIER VEHICLE

In order to disconnect the machine from the carrier vehicle, proceed as follows:

- After stopping the carrier vehicle, turn off all enabled functions on the sweeper control panel.
- Disengage PTO drive.
- Immobilise the machine with parking brake.
- Disconnect the control panel cable, lighting system cable and secure in the carrier vehicle.
- Disconnect pneumatic socket plugs from the carrier vehicle and place them on brackets on the sweeper drawbar.
- Disconnect the quick coupler of the hydraulic brake system (option) from the carrier vehicle and place it in the bracket on the sweeper drawbar.
- Disconnect the PTO shaft from the carrier vehicle and hang it on a hanger on the sweeper drawbar.
- Lower the parking stand.
- Disconnect the sweeper drawbar from the hitch and drive the carrier vehicle away.

I.2.6.588.08.1.EN

SECTION 6

MAINTENANCE

6.1 SERVICE INTERLOCK

Service interlock (Figure 6.1) is used to lock the waste container in raised position. Use service interlock during adjustments, servicing or repair of the machine. Service interlock is included in the sweeper equipment and is attached to the waste container, on the right side of the machine. (Figure 6.1)

In order to use the service interlock (Figure 6.1):

- Open the side cover and remove the lock.
- Raise the waste container as far as it will go.

see *SWEEPER OPERATION*



DANGER

Turn off the machine and install service interlocks before performing any maintenance, adjustment and repair activities near the raised waste container.

- *EMPTY THE WASTE CONTAINER*

- Disengage the machine drive.
- Place the lock (1) on the piston rod of the waste container lifting cylinder while standing on the right side of the machine.
- Install cotter pins (2).
- Lower the container until the interlock engages.

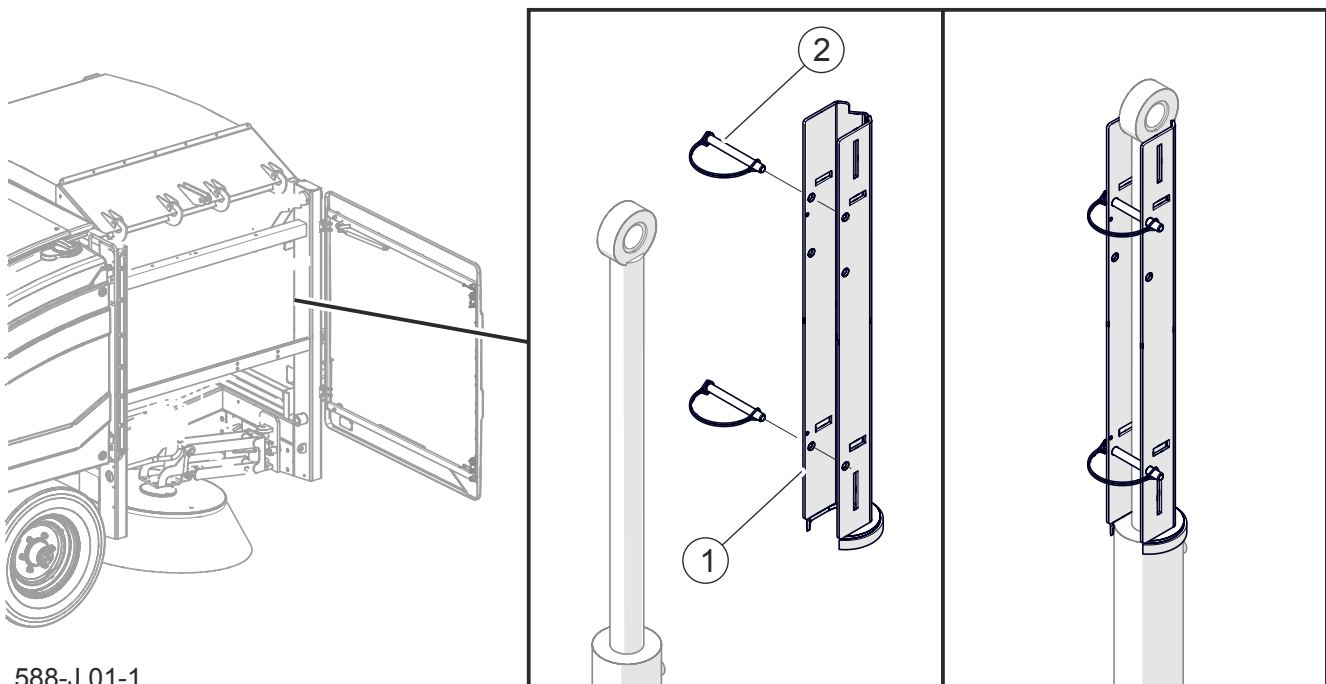

588-J.01-1

Figure 6.1 Service interlock

(1) service lock

(2) securing pin

J.2.6.588.01.1.EN

6.2 ADJUST THE SWEEPING UNIT AND CONVEYOR

ADJUST ROTARY DISC BRUSHES

Correctly positioned brush should touch the surface only with a section of its circumference in such a manner as to ensure that waste is directed to the inside of the sweeper. Adjustment of longitudinal and lateral tilt affects the rotary disc brush setting. Make certain that waste is not swept outside the machine. If necessary, adjust the sweep unit.

On a sweeper equipped with a brush hydraulic tilt control (optional), adjustment is made via the control panel from the operator's position.

see *SWEEPER OPERATION*

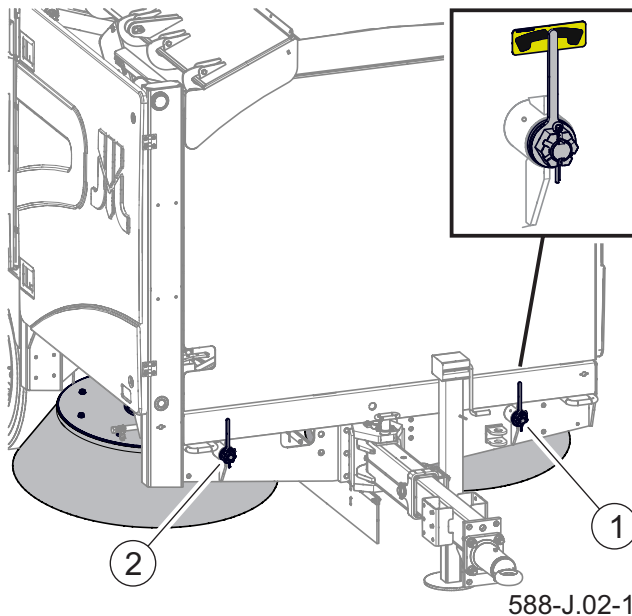

Figure 6.2 Tilt indicators of rotary disc brushes

(1) left brush tilt indicator
(2) right brush tilt indicator

- ROTARY DISC BRUSH TILT

Indicators (Figure 6.2) on the front section of the machine frame show the current transverse tilt of the brushes.

In the sweepers with mechanical adjustment of the left brush (Figure 6.3), lateral inclination of the brush is adjusted by means of a tensioner (1). Before the adjustment, loosen lock nut (2) and then, set proper brush tilt by turning the tensioner. After adjustment, tighten lock nut (2).

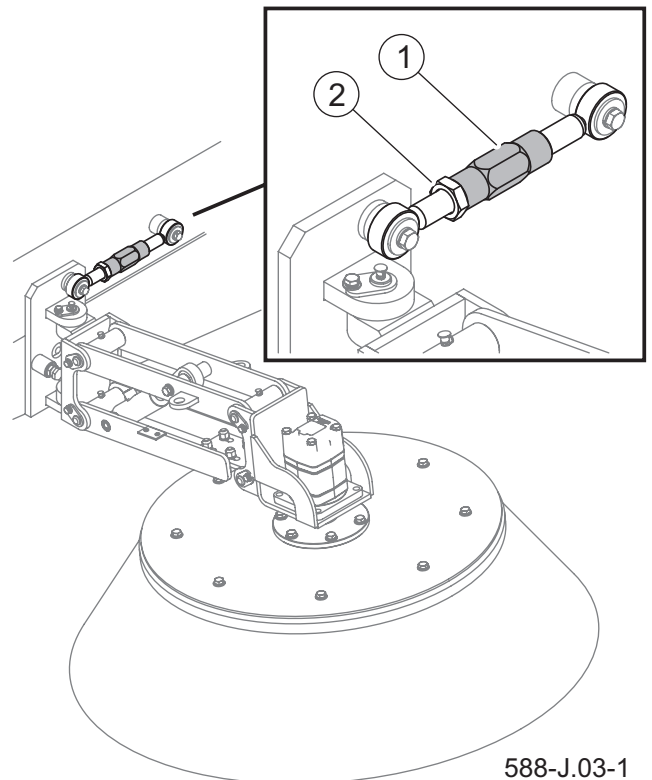

Figure 6.3 Mechanical transverse tilt adjustment

(1) rigging nut (2) lock nut

To adjust the longitudinal tilt (Figure 6.4), loosen the bolt nuts (1) then move the brush head (2) forward or backward. Longitudinal inclination of the right and left brush is set in the same manner. After adjustment, tighten nuts of bolts (1).

During sweeper operation, the disk brushes (Figure 6.5) swivel out of the machine. Range of horizontal movement of brushes is limited with bumper (1). Each of the roller brushes has two end stops. In order to change position of bumpers (1), loosen lock nut (2) and then, screw in or screw out the bumper (1). after adjustment,

tighten lock nut (2). Right brush and left brush can be set depending on a required sweeping width.

ADJUST SLIDES

There are sliders on both sides of the roller brush. (Figure 6.6). Position of slides with regard to the ground as well as their technical condition should be checked periodically. Slide should be positioned in such a manner as to slightly touch surface cleaned. Slide (1) suspension height is set by means of chain tensioner (2). If

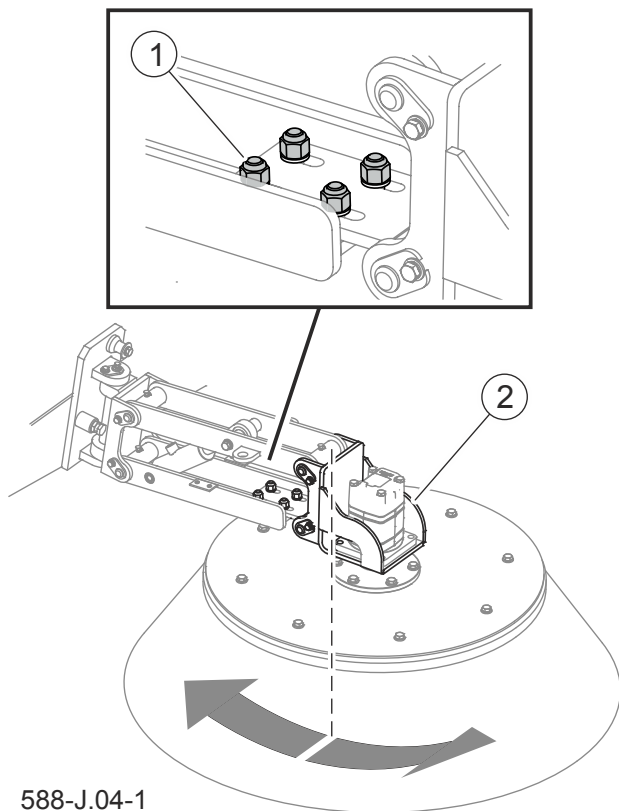

Figure 6.4 Adjust longitudinal tilt
(1) fixing bolts (2) brush head

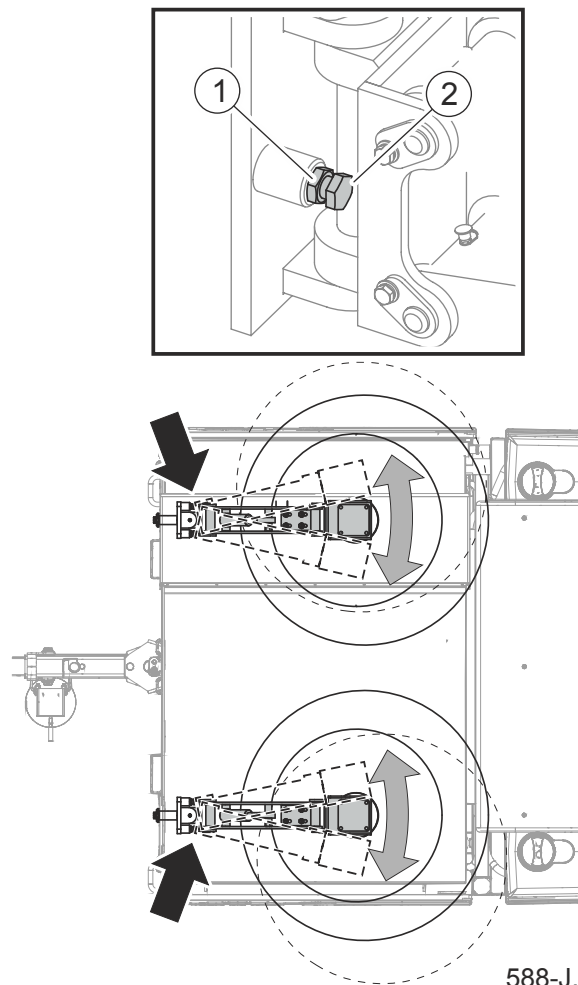

Figure 6.5 Side swing adjustment
(1) bumper (2) lock nut

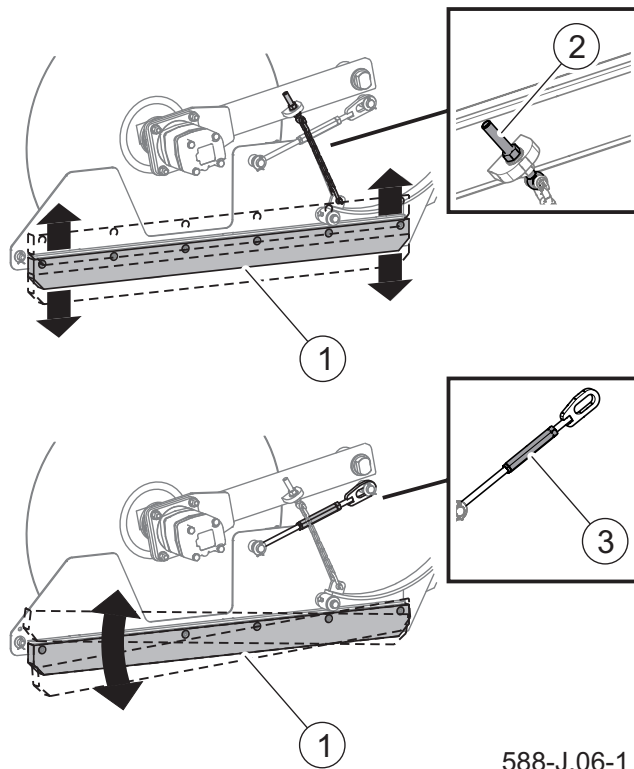

Figure 6.6 Slides adjustment
 (1) slide (Part No. 344N-06030001)
 (2) tensioner
 (3) turnbuckle

the range of tensioner (2) is insufficient, shorten the chain by changing position of shackles. Slide inclination is set by means of double ended bolt (3). Slide should be set in parallel to the surface cleaned. Positions of the slides on the right and left sides of the brush should be the same.

ADJUST CONVEYOR BELTS

Conveyor belts are tensioned on both sides of the conveyor (Figure 6.7). On both sides of the conveyor, loosen the lock nuts (4) and nuts (2) of the bearing mounting bolts. Move the tensioning shaft (1) with the tensioner bolt (3). This operation should be performed to the same extent on both sides of the conveyor.

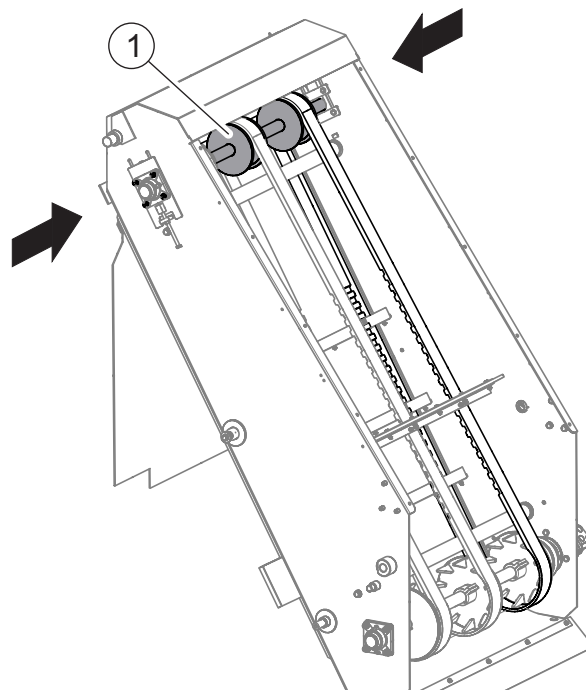
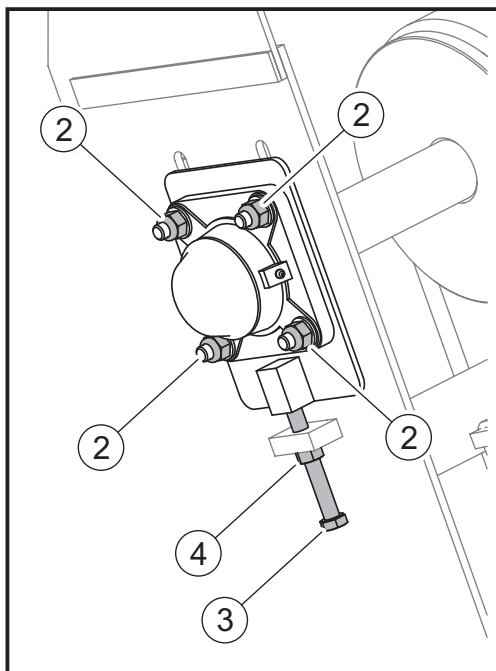

Figure 6.7 Tightening the elevator belts
 (1) tension roller
 (2) shaft bearing nuts
 (3) tensioner bolt
 (4) lock nut

588-J.07-1

Under a force of 160 N, the deflection of the belt should amount to 40-50 mm in the middle of its length. After adjusting both sides of the conveyor, tighten the locknuts (4) and nuts (2) securing the tensioning roller bearings (1).

TIP

When adjusting the conveyor belts, keep the tensioning and drive rollers parallel. Check that the scrapers are evenly aligned and that the belt tooth on the drive pulley has not skipped

J.2.6.588.03.1.EN

6.3 REPLACE BRUSHES AND CONVEYOR COMPONENTS

REPLACE ROTARY DISC BRUSHES

The sweeper is equipped with two identical disk brushes. Depending on your needs, you can use brushes with the following hardness:

- hard brush (100.A473)
- soft brush (344N-07000003)
- medium brush (344N-07000004)

The rotary disc brushes (Figure 6.8) can be replaced as follows:

- undo the nuts (3) of the bolts securing the brush (1) on the disc,
- Attach the new brush to the disc using bolts (2), nuts (3) and washers (4).



DANGER

Before inspection and replacement of brushes, turn off the machine drive, turn off the tractor engine and the control panel and ensure that unauthorised persons have no access to the vehicle cab.

TIP

Technical condition of the brushes should be checked periodically. Excessively worn brushes must be replaced with new ones.

TIP

Excessive pressure of brush on the surface increases wear of brush.

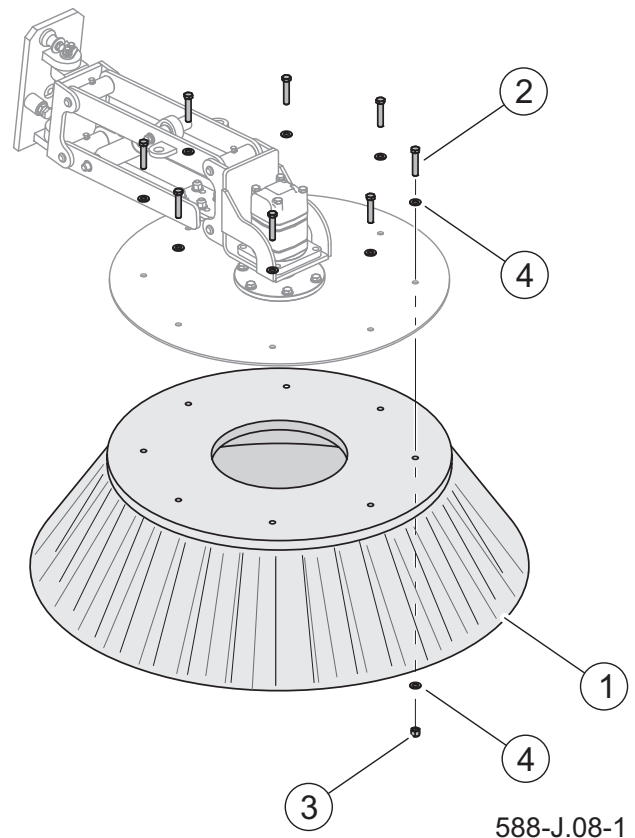

Figure 6.8 Replacement of disk brushes

- (1) rotary disc brush (2) bolt
(3) nut (4) washer

REPLACE THE ROLLER BRUSH

To remove the roller brush (Figure 6.9):

- On the left side of the brush, undo and remove bolts that fix the bearing

to the brush bracket.

- Remove the housing with bearing (5).
- Pull out the brush with the axle to the left.

Table 6.1. Roller brush types (Figure 6.9)

LP	Name	Part number	Number of items
Hard roller brush			
1	straight ring brush (plastic 2x3mm)	588N-00000002-01	6
2	curved ring brush (wire 0,7mm)	588N-00000001	28
Soft roller brush			
1	straight ring brush (plastic 2x3mm)	588N-00000002-01	6
2	curved ring brush (plastic 2x3mm)	588N-00000001-01	28

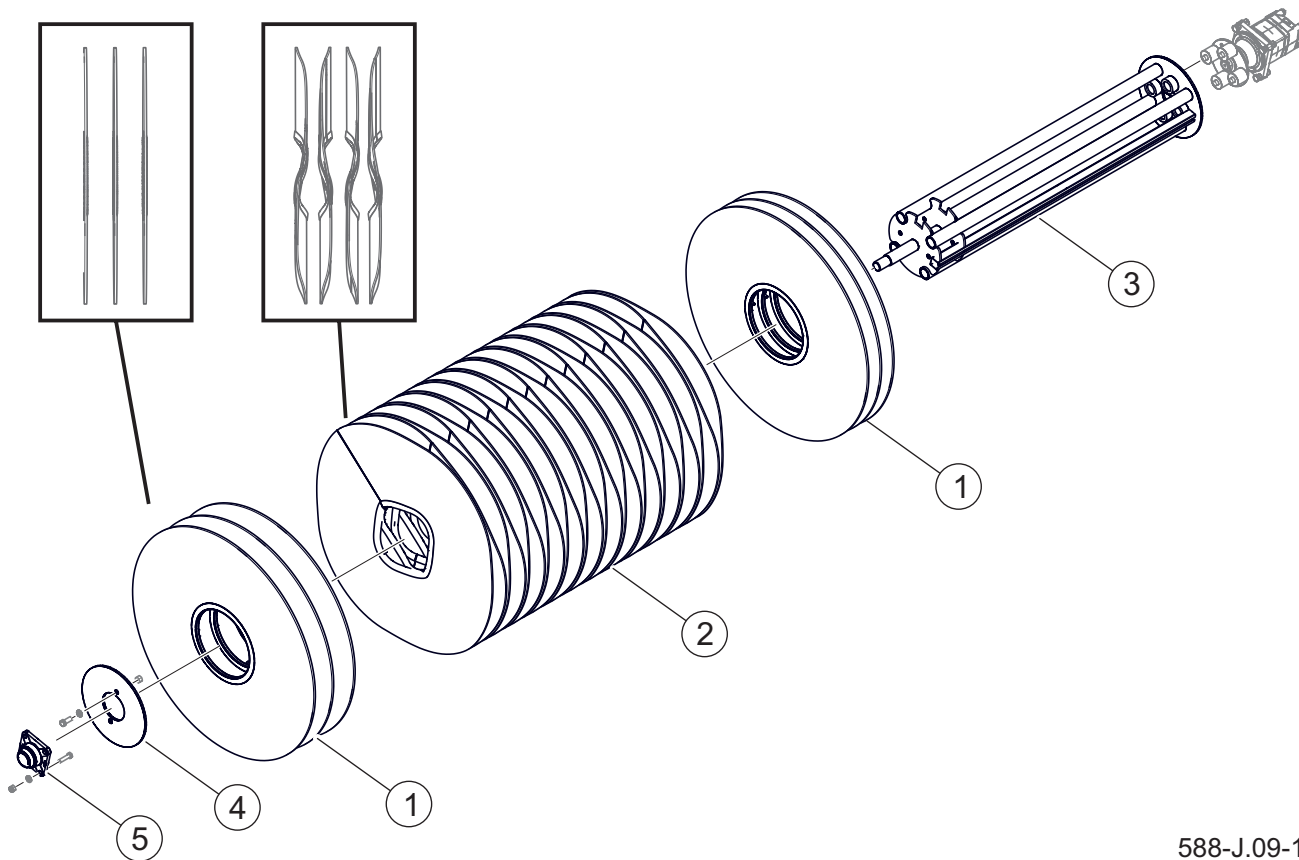

588-J.09-1

Figure 6.9 Replace the roller brush

(1) straight ring brush (2) curved ring brush (3) axle (4) clamp (5) housing with bearing

- Remove the clamp (4).
- Remove the housing with bearing (5) from the axle and remove the clamp (4).
- Remove the worn brush segments from the axle and install the new brush segments in the correct order.
- Reassemble in reverse order.

REPLACE CONVEYOR SCRAPERS

The technical condition of belts and conveyor scrapers should be checked periodically (Figure 6.10). Excessively worn or damaged blades must be replaced.

TIP

The sweeper is equipped with 13 scrapers (part number 344N-05090003)

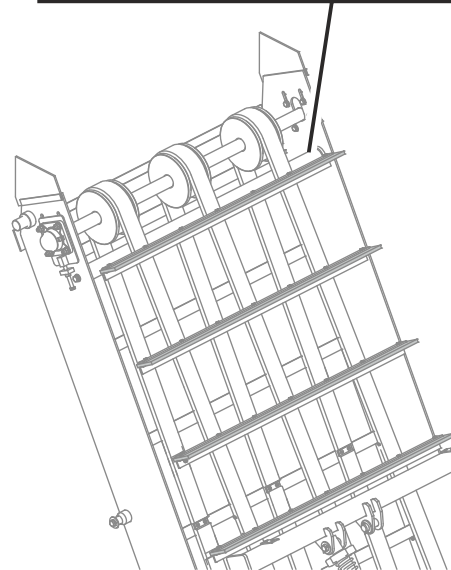
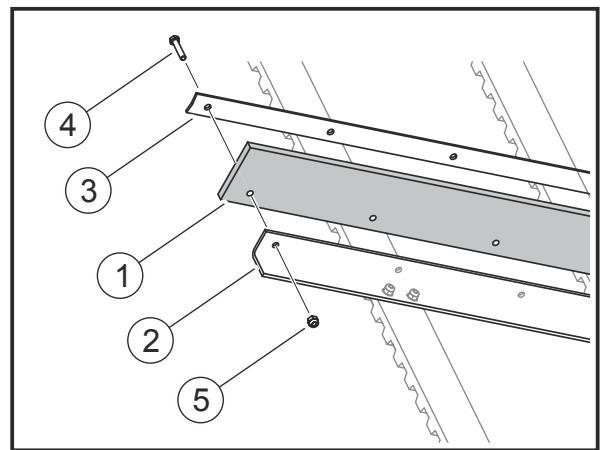

588-J.10-1

Figure 6.10 Conveyor scrapers

(1) scraper

(2) clamp

(3) strip

(4) bolt

(5) nut

J.2.6.588.03.1.EN

6.4 HYDRAULIC SYSTEM MAINTENANCE

Hydraulic system maintenance duties:

- check oil level in the hydraulic system tank,
- check tightness of cylinders and hydraulic connections,
- check the technical condition of lines;
- periodical replacement of filters,
- periodical changing of oil in the hydraulic system tank.

The sweeper hydraulic system should be completely tight. Checking tightness of the hydraulic system involves connecting the sweeper with the tractor and activating the hydraulic system. If an oil leak is found on hydraulic connections, tighten the connections. If this does not remedy the problem, replace the lines and connection components. If oil leak occurs beyond connection, the leaking conduit of the system should be changed. Always exchange each mechanically damaged component. In the event of confirmation of damage to hydraulic motors, they must be repaired or replaced.

Because of its composition, the oil is not classified as a dangerous substance, however long-term action on the skin or eyes may cause irritation. In the event of contact of oil with skin wash the place of contact with water and soap. Do NOT



DANGER

Before commencing whatever work on hydraulic system reduce the residual pressure in the system.

apply organic solvents (petrol, kerosene). Contaminated clothing should be changed to prevent access of oil to skin. In the event of contact of oil with eye, rinse with large quantity of water and in the event of the occurrence of irritation consult a doctor. Hydraulic oil in normal conditions is not harmful to the respiratory tract. A hazard only occurs when oil is strongly atomised (oil vapour), or in the case of fire during which toxic compounds may be released. The hydraulic system must be tight. Minimum leaks are permissible with symptoms of "sweating", however in the event of noticing leaks in the form of "droplets" stop using the machine until faults are remedied.



DANGER

During work on hydraulic system, use the appropriate personal protection equipment i.e. protective clothing, footwear, gloves and eye protection. Avoid contact of skin with oil.



IMPORTANT

Hydraulic lines should be replaced every four years.

**DANGER**

Oil fires should be quenched with carbon dioxide (CO₂), foam or extinguisher steam.
Do NOT use water for fire extinguishing!

Spilt oil should be immediately collected and placed in a marked tight container. Used oil should be taken to the appropriate facility dealing with recycling or regeneration of oils.

HYDRAULIC OIL TANK

Should it be necessary to change hydraulic oil for another oil, check the recommendations of the oil Manufacturer. If it is recommended to flush the system with the appropriate preparation, then comply with these recommendations. Make sure that the chemicals used for this purpose do not damage the materials of the hydraulic system.

Periodically check oil level on the oil level gauge (3).

Low oil level is indicated by the icon (4) on the LCD (Figure 6.11)

Before changing oil, start the machine and wait until oil gets slightly warmer.

To change oil (Figure 6.12):

- prepare a pan for used oil,
- unscrew filler plug (1),
- unscrew drain plugs (2) on the bottom of the tank and drain oil to previously prepared container,

**DANGER**

Do not repair hydraulic system on your own. All hydraulic system repairs must be performed only by suitably qualified personnel.

**IMPORTANT**

Before starting work, visually inspect the hydraulic system components.

**DANGER**

Activities connected with maintenance of hydraulic system (inspection, replacing and adding oil, replacing filters) should be carried out only when the machine is switched off.

During maintenance work concerning the machine, „EMERGENCY STOP” button on the control panel should be depressed.

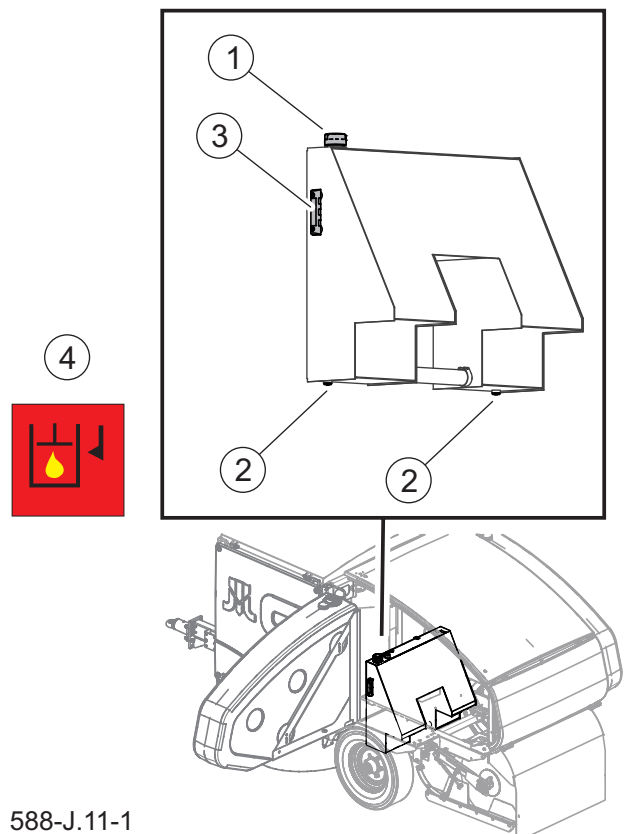

588-J.11-1

Figure 6.11 Check oil level

(1) filler plug

(3) oil level indicator

warning icon

(2) drain plug

(4) low oil level

TIP

The hydraulic system is filled with 190L (litres) of L-HL46 hydraulic oil.

**DANGER**

The machine with a leaking hydraulic system must NOT be used.

The condition of hydraulic systems should be inspected regularly while using the machine.

The hydraulic system is under high pressure when operating.

Regularly check the technical condition of the hydraulic lines and connections.

Use the hydraulic oil recommended by the Manufacturer. Never mix two types of oil.

TIP

Oil in the hydraulic system tank should be replaced every 500 engine working hours or once a year, whichever occurs first.

- tighten drain plugs (2), fill tank with oil and tighten filler plug (2),
- check the oil level on the tank oil indicator (3).

When changing the oil, the pressure filters and the return filter must be replaced. The hydraulic system is vented automatically during machine operation.

INLET FILTER

Inlet filter (1) is located inside inlet opening and should be inspected and cleaned periodically. Open the rear left-hand cover to gain access to the inlet filter (Figure 6.11). Unscrew cap (2), take out mesh filter cartridge (1) and clean in washing agent.

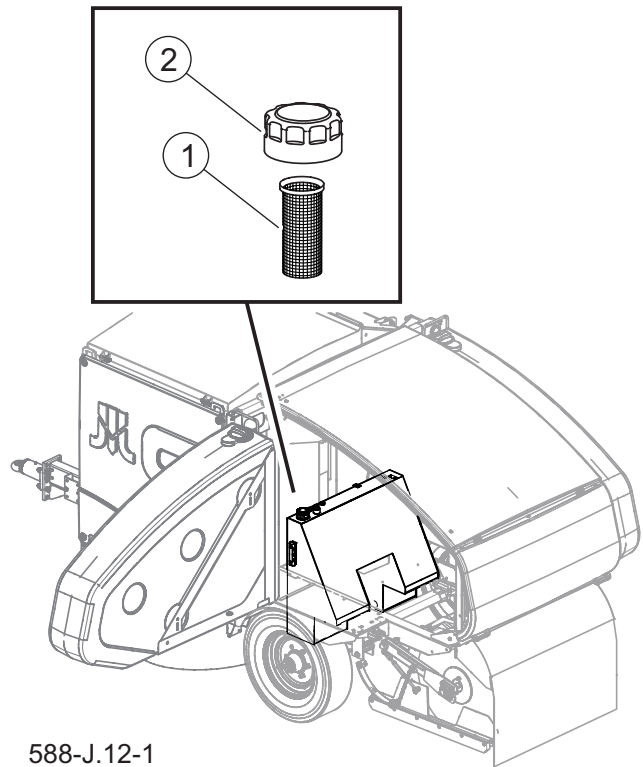

588-J.12-1

Figure 6.12 Inlet filter

(1) filter mesh cartridge (2) filler plug

PRESSURE FILTER

The machine's hydraulic system features two pressure oil filters (Figure 6.13, Figure 6.14) fitted with an indicator (2). If filter element is contaminated, the indicator changes its colour to red. Within the scope of hydraulic system maintenance, check the indicator (2) and replace filter element (1), if necessary.

TIP

Pressure filters of the hydraulic system are equipped with replaceable filter cartridges.

Filter cartridge of pressure oil filter should be replaced when the indicator located on the filter indicates filter contamination. The indicator should be checked after oil has reached its working temperature.

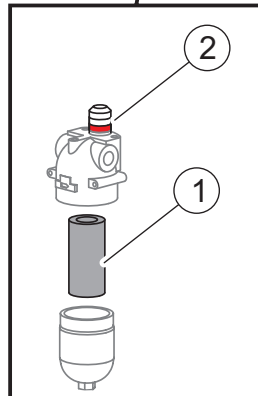
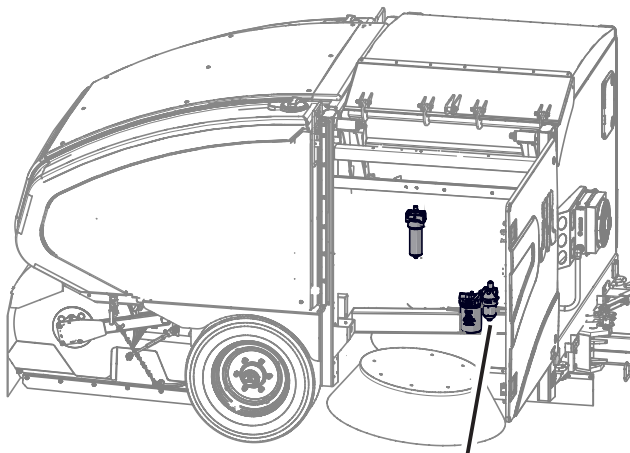

588-J.13-1

Figure 6.13 Pressure filter 2
(1) filter cartridge (CCH 301 FD1)
(2) contamination indicator

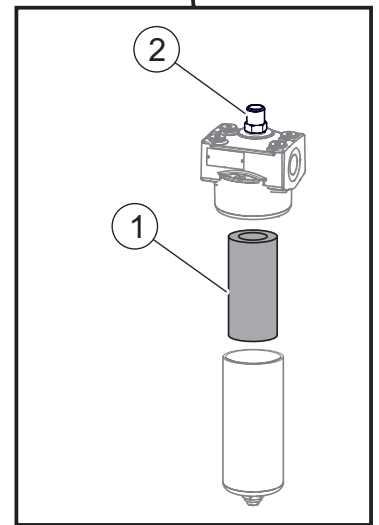
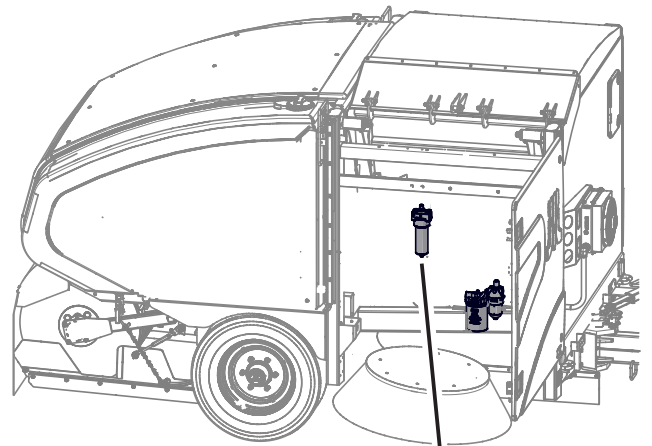

588-J.14-1

Figure 6.14 Pressure filter 1
(1) cartridge (944431Q or SE-030-G-05-B/X)
(2) filter contamination indicator

RETURN FILTER

Return filter (Figure 6.14) of hydraulic system is equipped with indicator (2). If filter is contaminated, the indicator changes its colour to red. Within the scope of hydraulic system maintenance, check the indicator and replace filter (1), if necessary. Before installing a new filter, oil the gasket surface. Screw in filter by hand, without use of any tools.

TIP

There is a replaceable return oil filter in the hydraulic system. Filter cartridge designation: MXR9550 or SFC-5710-E (*depending on filter model*) Return oil filter should be replaced when the indicator (1) located on the filter indicates filter contamination. The indicator should be checked after oil has reached its working temperature. After replacing the filter, tighten it by hand without the use of tools.

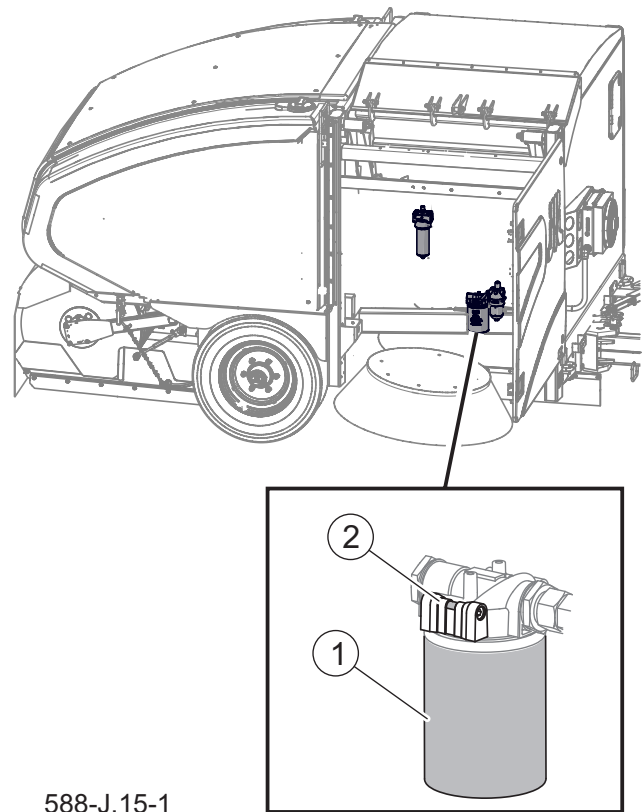

588-J.15-1

Figure 6.15 Return filter

- (1) cartridge (No. MXR9550 or SFC-5710-E)
- (2) filter contamination indicator

J.2.6.588.04.1.EN

6.5 MULTIPLIER GEAR BOX MAINTENANCE

Each time before starting work, check oil level in the multiplier gear box. To do this, place the machines horizontally. The correct oil level should reach the half of the sight glass on the multiplier gear box housing.

Operating the transmission with insufficient amount of oil or without oil may cause permanent damage.

Only add or change oil when the machine is disconnected from the carrier vehicle.

To change oil in multiplier gear box (Figure 6.16):

- prepare a pan for used oil,
- unscrew filler plug with air vent (1),
- unscrew the drain plug (2), drain the oil into a pan and screw in the drain plug,
- pour new oil through plug opening (1) to the level visible in the inspection opening (3),
- screw in the filler plug (1).

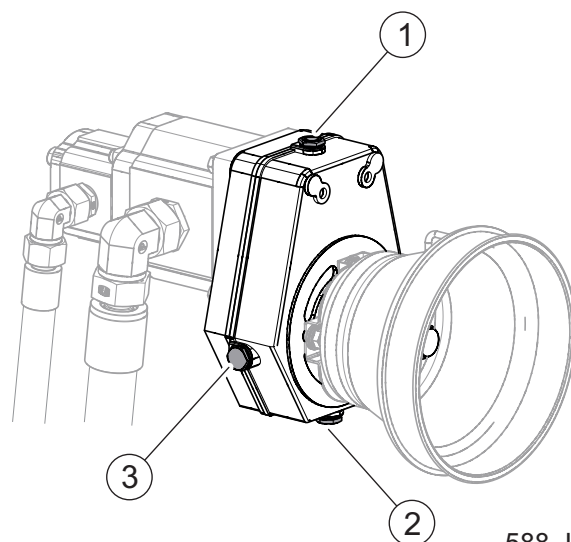

588-J.16-1

Figure 6.16 multiplier gear box

(1) filler plug with breather

(2) drain plug

(3) oil level sight glass

TIP

Oil in the multiplier gear box should be replaced every 500 working hours or once a year, whichever occurs first.

The multiplier gear box is lubricated with 0.5 litre of oil of SAE 90 class.

J.2.6.588.05.1.EN

6.6 SPRAY SYSTEM SERVICE

Spray system maintenance involves periodic inspection of water system, cleaning of water filters and checking oil level in water pump.

TIP

If there is a risk of freezing temperature during storage, the spray system should be emptied of water (especially the pump, filter and nozzles).

SPRAY NOZZLES

Before first use, check spray nozzle operation, especially the setting of spray nozzles. Periodically confirm that spray nozzles are not clogged and filters are clean (Figure 6.17). There is a strainer in the spray nozzle. In order to clean the strainer, dismantle nut with spray nozzle. Rinse the strainer or blow it with compressed air. Check spray nozzle for obstruction. Check technical condition of spray nozzles and, if necessary, replace damaged elements.

WATER FILTER

In the spray system there is a filter (1) which catches mechanical contaminants. In order to clean water filter (Figure 6.18), unscrew housing (2) and remove the strainer (1) and wash it with water or blow with compressed air. Install cartridge, tighten housing elements and check tightness of

TIP

Water filters are recommended to be cleaned at least once a year. Frequency of filter cleaning depends on amount and size of water contamination.

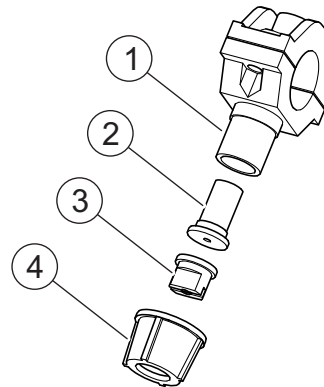

588-J.17-1

Figure 6.17 Spray nozzles

- | | |
|------------------|-----------------------|
| (1) housing | (2) filter with valve |
| (3) spray nozzle | (4) nut |

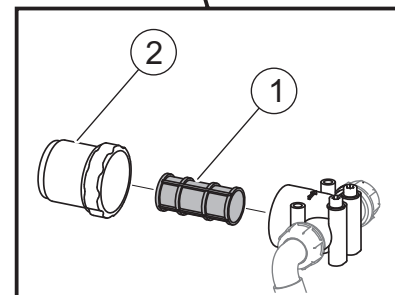
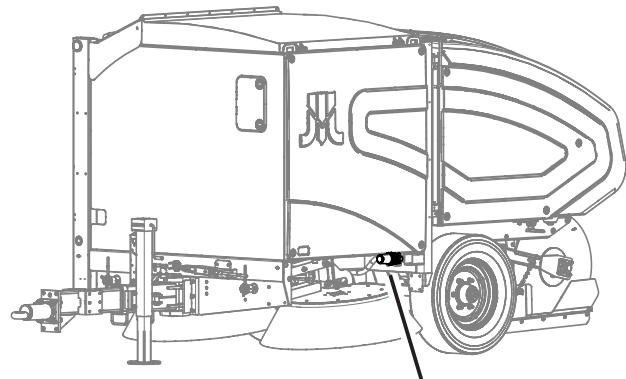

588-J.18-1

Figure 6.18 Water filter

- | | |
|---------------------------|-------------|
| (1) filter mesh cartridge | (2) housing |
|---------------------------|-------------|

connection.

WATER PUMP

Level of oil in the water pump lubrication system should be checked periodically. With the machine turned off, the oil level (Figure 6.19) in the water pump should be between the "min" and "max" marks visible on the filler neck.

EMPTY THE SPRAY SYSTEM

If there is a risk of freezing temperature during storage, the spray system should be emptied of water (especially the pump, filter and nozzles). Drain the system in the following order:

- Drain the water tanks by opening the valve and drain plug.
- Remove the water filter cup.
- Remove the spray nozzles and check valves.
- Disconnect the hoses from the pump (suction, overflow and pressure).
- Start spraying for 30 seconds to remove water from the pump, then turn off for about a minute and run it again for 30 seconds.
- Reassemble the system.

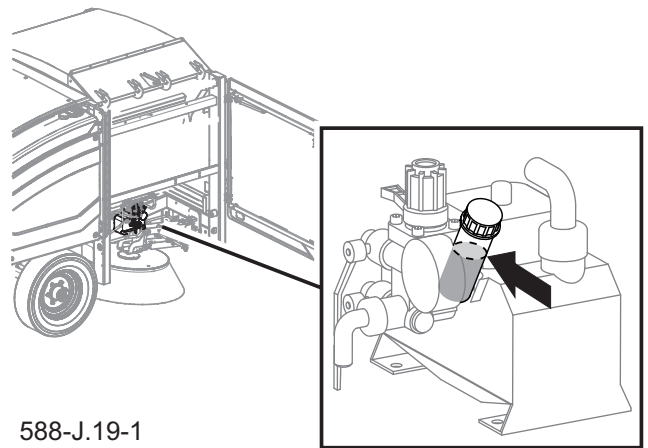

588-J.19-1

Figure 6.19 Oil level in the water pump

TIP

Water pump lubrication system is filled with mineral oil of SAE 10W40 or 15W30 class for gasoline engines.



DANGER

Turn off the machine before you check the oil level in the water pump lubrication system and change the pump operation settings.



IMPORTANT

Maximum water pressure during spray system operation must not exceed 10 bar.

J.2.6.588.06.1.EN

6.7 ELECTRICAL SYSTEM MAINTENANCE



DANGER

Do not independently repair electrical system, except items described in chapter ELECTRICAL SYSTEM MAINTENANCE. All electrical system repairs must be performed only by suitably qualified personnel.

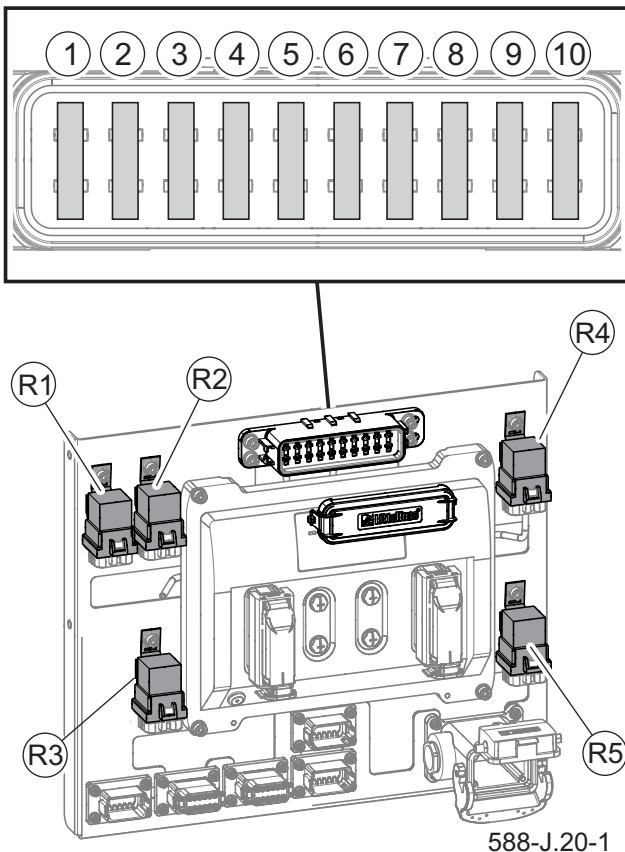

Figure 6.20 Sweeper fuses and relays

(R1) power relay

(R2) vibrator relay

(R3) fan relay

(R4) water pressure control relay

(R5) water pressure control relay

(1) 10A fan fuse

(2) 2A controller fuse

(3-7) 15A controller fuse

(8) 10A sensors fuse

(9) 2A controller fuse

(10) 20A vibrator fuse

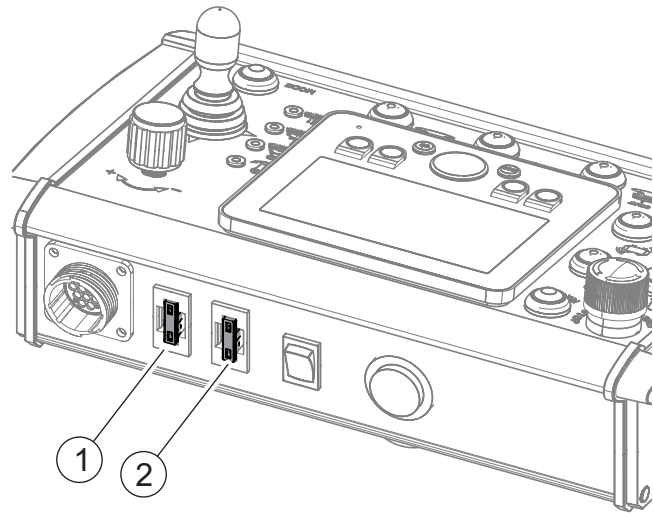

588-J.21-1

Figure 6.21 Control panel fuses

(1) LCD fuse -2A

(2) CAN controller -10A fuse

Electrical system maintenance is conducted during the periodical inspection of the control and lighting system operation. The electrical system fuse is located on the right side of the sweeper above the controller (Figure 6.20). The fuses can be accessed after opening the right front cover.

The UNIVAL fuses of the CAN controller and the LCD are located on the rear casing of the control panel (Figure 6.21).

There is a MIDIVAL 70A fuse on the power cable that connects to the positive terminal of the carrier's battery.

List of bulbs		
Lamp name	Part number	Type of bulb
TAIL LAMP, RIGHT	2VA998232-287	P21W P21/5W
TAIL LAMP, LEFT	2VA998232-277	P21W P21/5W

6.8 BRAKE ADJUSTMENT

ADJUST THE MAIN BRAKE

Brakes adjustment is necessary when:

- as a result of wear of brake shoe linings between lining and drum there is excessive slack and reduced braking effectiveness,
- wheel brakes do not brake evenly or simultaneously.

If brakes are correctly adjusted, braking of machine road wheel takes place simultaneously.

Brakes (Figure 6.22) adjustment involves changing setting of axle shaft expander arm (1) in relation to expander shaft (2). To do this, place expander arm on the end of the multisplined shaft in the correct direction:

- in direction of hydraulic cylinder - if brake brakes too late,
- in direction from hydraulic cylinder - brake brakes too early.

Adjustment should be conducted separately for each wheel.

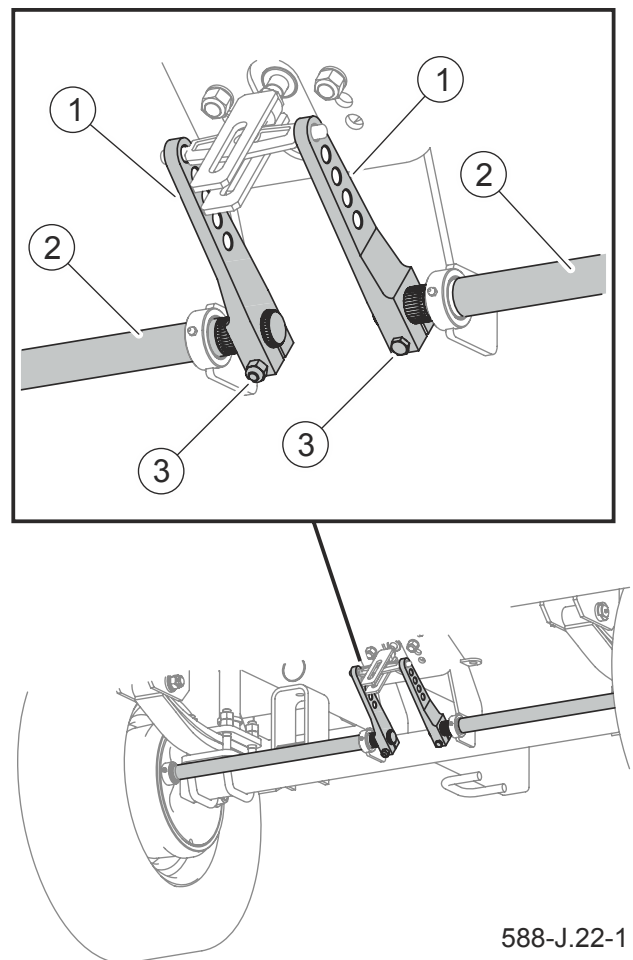

588-J.22-1

Figure 6.22 Brakes adjustment

(1) expander arm (2) expander shaft (3) compression bolt

After proper brake adjustment, at full braking the expanders' arms should create the angle of 90° with the pneumatic cylinder piston.

ADJUST THE PARKING BRAKE

Adjustment of parking brake should be conducted in the event of:

- stretching of cable,
- loosening of parking brake cable clamps,
- after adjustment of main brake,
- after repairs in main brake system,
- after repairs of parking brake system.

Before commencing adjustment make certain that the main brake is functioning properly.

- place chocks under the wheel,
- fully unscrew the bolt of the brake crank mechanism (1),
- loosen nuts (5) of clamps,
- tighten cable and tighten nuts.

The length of the parking brake cable should be adjusted so that the cable is not tight when the working and parking brake

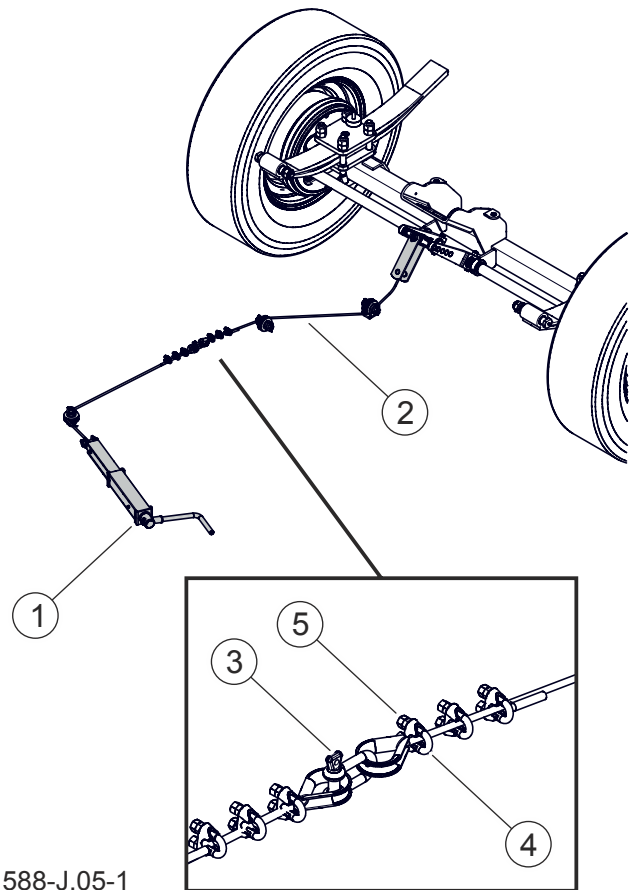

588-J.05-1

Figure 6.23 Brakes adjustment

- | | |
|---------------------|--------------------|
| (1) crank mechanism | (2) cable |
| (3) shackle | (4) U-shaped clamp |
| (5) nuts | |

are completely released.

J.2.6.588.08.1.EN

6.9 PNEUMATIC SYSTEM MAINTENANCE

The user responsibilities relating to the operation of the pneumatic system:

- cleaning the air filters,
- cleaning and maintaining pneumatic conduit connections,
- Drain water from air tank, clean the valve,
- check air tightness of pneumatic system.

As a part of sweeper maintenance, conduct inspection of pneumatic system leaktightness, paying particular attention to all places of connection. Tightness of the system should be checked at nominal pressure in the system.

If lines, seals or other system elements are damaged, compressed air will escape in these damaged places with a characteristic hiss. It is recommended to use preparations commercially available designed to facilitate detecting air leaks. Small leaks may be exposed by covering checked elements with washing fluid or other foaming preparations, which will not react aggressively with system components. Damaged components should be replaced or repaired. If leaks appear at connections then tighten the connections. If air continues to escape, replace connection components or seals with new ones.



DANGER

Works related to the repair, replacement or regeneration of pneumatic system components (cylinder, lines, control valve, etc.) should be entrusted to specialized service points.

During tightness inspection attention should additionally be given to technical condition and degree of cleanness of the system components. Contact of pneumatic conduits, seals etc. with oil, grease, petrol etc. may cause damage and accelerate the ageing process. Bent, permanently deformed, cut or worn conduits should be replaced.

AIR TANK

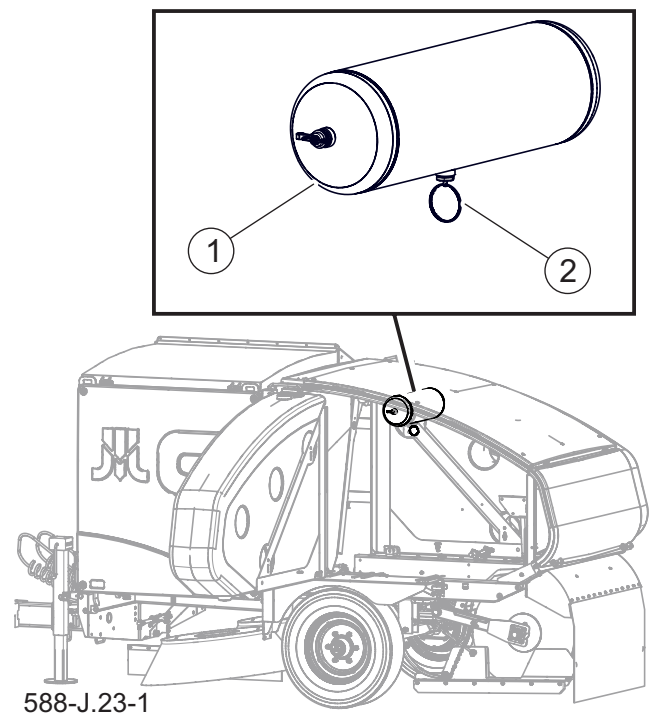

Figure 6.24 Air tank

(1) air tank

(2) drain valve

Condensation collecting as water should be removed from air tank periodically. (Figure 6.24) In order to do this open out drain valve placed in lower part of tank. The compressed air in the tank causes the removal of water to the exterior. Released valve stem should automatically close and stop flow of air from the tank. In the event, that the valve stem resists returning to its setting, then the whole drain valve must be unscrewed and cleaned, or replaced (if it is damaged).

AIR FILTER

Depending on the operating conditions, but not less frequently than once every three months, remove and clean the air filter cartridges located in the pneumatic system connection lines. Filter elements are used many times and are not subject to change unless they are mechanically damaged.

In order to clean the filter cartridge:

- Reduce pressure in supply conduit.
- Pull out the securing latch holding the filter cover.

The cover will be pushed out by a spring located in the filter housing.

The filter element and the filter body should be carefully washed out and blown through with compressed air. Install in reverse order.

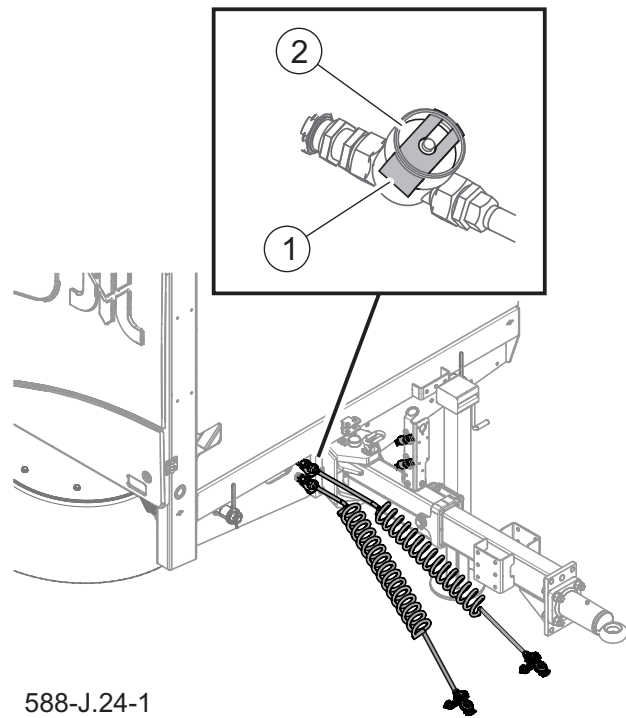

588-J.24-1

Figure 6.25 Air filter

(1) damper

(2) filter cover



DANGER

Before proceeding to dismantle filter, reduce pressure in supply conduit. While dismantling the filter slide gate, hold the cover with the other hand. Stand away from filter cover vertical direction.

TIP

The insert and the air filter body should be cleaned at least every 3 months of machine use.

PNEUMATIC CONNECTIONS

Pneumatic system connections must be inspected on regularly during use of machine and if necessary cleaned of all contamination. Pay attention to the technical condition of security covers and rubber seals. If these elements are damaged they should be replaced. Contact of the seals with fuel, lubricants being petroleum

derivatives, paints etc., causes rapid ageing of the material from which they are made. Before the winter period, it is recommended to preserve seal with special preparations. (e.g. silicone preparations). Each time before connection of the machine inspect technical condition and cleanness of contacts and sockets

in carrier vehicle. If necessary, clean or repair the connection sockets.

TIP

Connection should be inspected every time before connecting machine to carrier vehicle. During connection make sure that socket is not damaged and is maintained in the due cleanliness.

J.2.9.588.09.1.EN

6.10 CHECK AND ADJUST WHEEL AXLE BEARINGS

In newly purchased machine, after covering a distance of 100 km, while during further use – after 6 months of vehicle use check and adjust wheel axle bearings when needed. Worn or damaged bearing should be replaced. Check the bearing play follows:

- Connect the sweeper with the carrier vehicle, brake the carrier vehicle.
- Place chocks under the sweeper wheel. Lift the wheels one by one with a suitable jack. The lifting jack should be placed under the axle on one side of the machine, alternately for each wheel.
- Check bearing play and re-adjust if necessary.

Adjust wheel axle bearings (Figure 6.26) as follows:

- Remove the hub cover and take out the cotter pin.
- Turning the wheel simultaneously tighten castellated nut until the wheel comes to a stop.
- Unscrew nut by $\frac{1}{3}$ of a turn until the nearest cotter pin groove aligns with opening in wheel stub axle.
- Secure castellated nut with cotter pin and mount hub cap. The wheel



IMPORTANT

Bearing replacement, lubrication and repairs of the axle system should be performed by specialized service points.

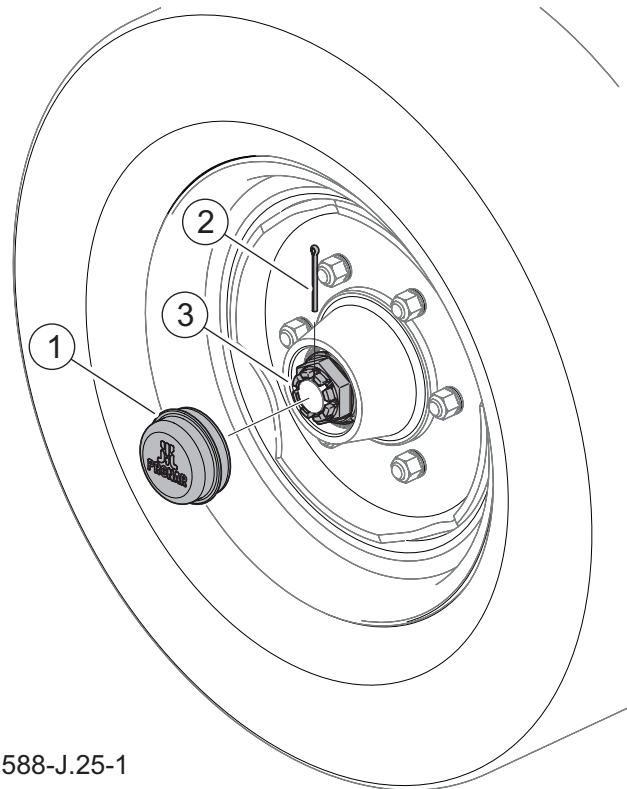

588-J.25-1

Figure 6.26 Adjust axle bearings

(1) hub cover

(2) cotter pin

(3) castellated nut

should turn smoothly without faltering or detectable resistance not originating from abrasion of brake shoes in brake drum.

Inspect and adjust wheel axle bearings may be carried out only when the waste container is empty.

6.11 WHEEL MAINTENANCE

REMOVE WHEEL

- Place chocks under the wheel that will not be dismantled.
- Ensure that machine is immobilised when wheel is being removed.
- Loosen wheel nuts.
- Place lifting jack and lift rotary rake.
- Dismount wheel.

INSTALL WHEEL

- Clean the wheel axle pins as well as the seating surfaces and nuts of any contamination.
- Do not grease thread of nuts and pins.
- Check condition of pins and nuts, if necessary replace them.
- Place wheel on hub, tighten nuts so that wheel rim tightly fits the hub.

Lower the machine, tighten nuts according to recommended torque and given sequence.

TIGHTENING NUTS

Nuts should be tightened gradually diagonally, (in several stages, until obtaining the required tightening torque) using a torque spanner.

Check tightening of half axle wheel nuts:

- after the first use of the trailer,
- after first day of work,
- at regular intervals (50 h).



IMPORTANT

If you use hydraulic jacks, use additional mechanical supports.

TIP

Tighten the wheel nuts with a torque of 270-290 Nm

The inspection should be repeated individually if a wheel has been removed from the wheel axle.

The greatest precision is achieved using a torque spanner. Before commencing work, ensure that correct tightening torque value is set.

CHECK AIR PRESSURE IN TYRES, TECHNICAL CONDITION OF TYRES AND STEEL RIMS

Tyre pressure should be checked each time after changing spare wheel and not less than every month. In the event of intensive use, air pressure in tyres should be checked more frequently. Check tyres before you drive off when tyres are not warm, or after the machine has been parked for an extended period.

While checking pressure pay attention to technical condition of wheels and tyres.

Look carefully at tyre sides and check the condition of tread.

In case of mechanical damage consult the nearest tyre service and check whether the tyre defect requires tyre replacement.

Wheels should be inspected with regard to distortion, breaking of material, breaking of welds, corrosion, especially in the area of welds and contact with tyre.

Proper technical condition and appropriate maintenance of wheels significantly extends the life of these components and ensures appropriate level of safety to machine users.

Check air pressure in tyres and visual inspection of steel wheels:

- at regular intervals (100h),
- if needed.

TIP

Tyre pressure 7 ± 1 bar

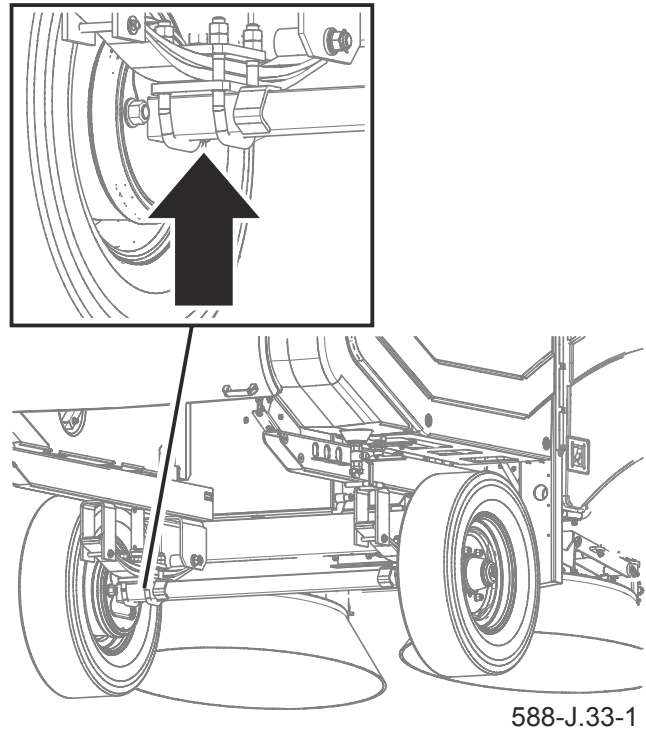

Figure 6.27 Lifting jack support point

J.2.6.586.11.1.EN

6.12 LUBRICATION

Lubricate the machine using a grease gun, filled with LT-43-PN/C-96134 grease. Clean the lubrication points before lubricating. Remove and wipe off excess oil or grease. Additionally, the PTO shaft must be lubricated in accordance with the operator manual provided by the shaft manufacturer.

Before lubricating, secure the machine against unintentional starting up.

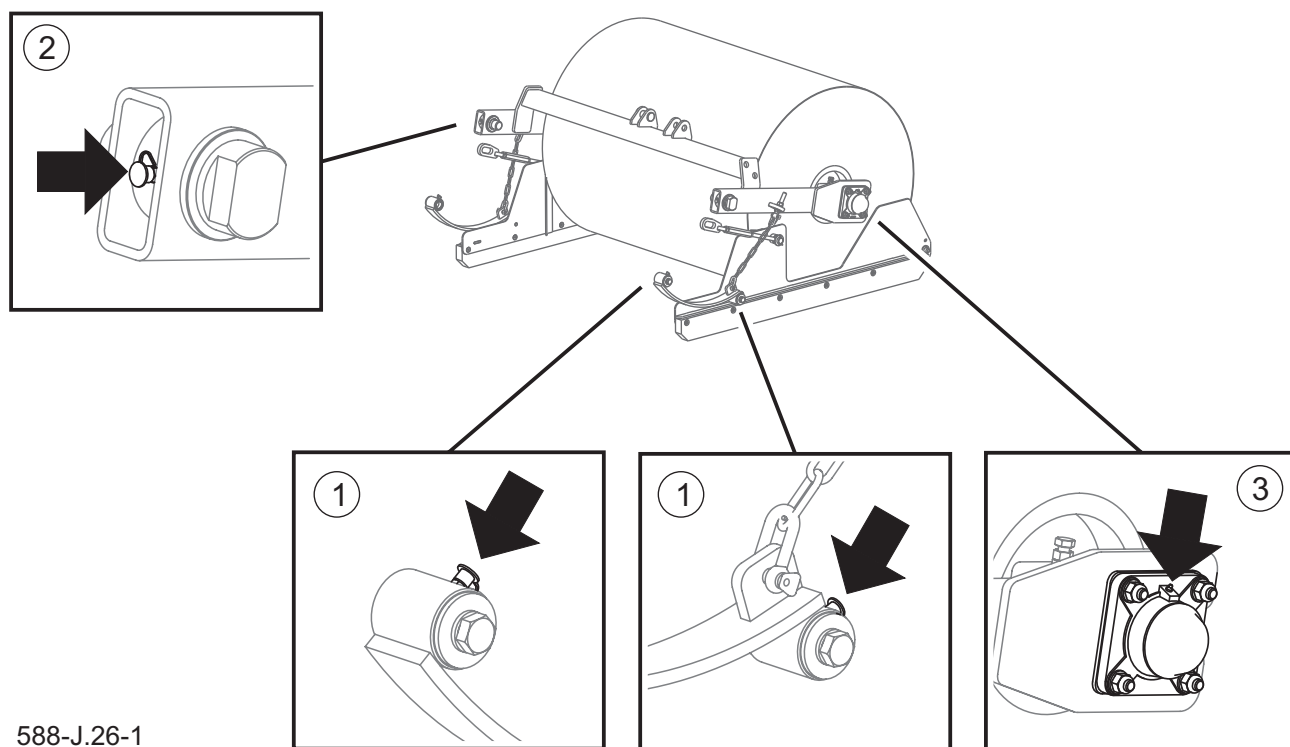

588-J.26-1

Figure 6.28 Roller brush lubrication

(1) cover support sleeves (2) Sleeves of brush frame (3) roller brush bearing

Item	Name	Number of points	Type of lubricant	Frequency grease
1	Front pin of brush rising mechanism	2	grease	25 hours
2	Rear pin of brush rising mechanism	2		
3	Brush arm tilt pin	2		

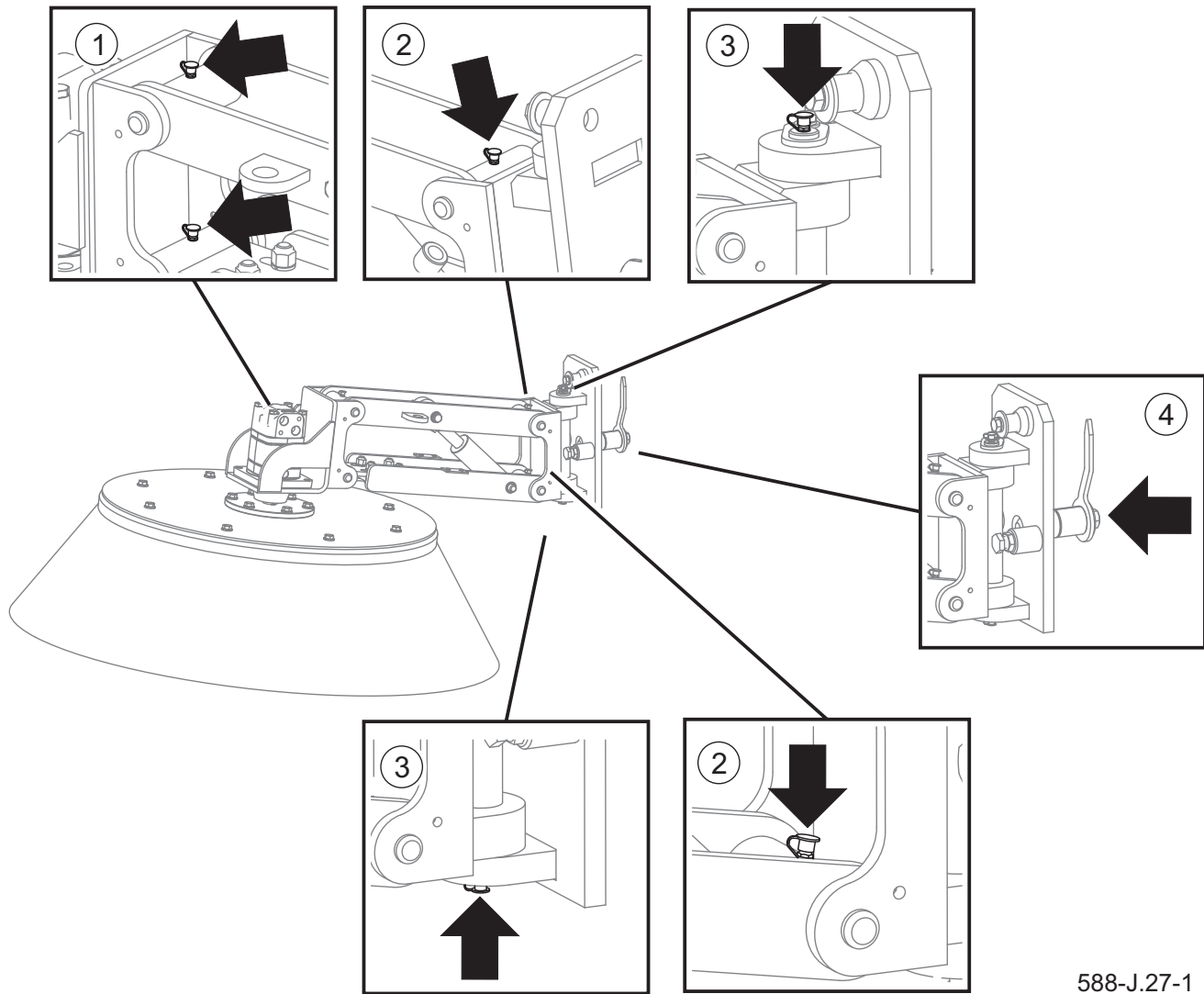

588-J.27-1

Figure 6.29 Lubricate the rotary disc brush mechanisms

(1) (2) lifting mechanism pins

(3) brush arm rotation pin

(4) brush arm tilting axis

Item	Name	Number of points	Type of lubricant	Frequency grease
1	Front pin of brush rising mechanism	2	grease	25 hours
2	Rear pin of brush rising mechanism	2		
3	Arm swing pin	2		
4	Arm tilt axis	1		

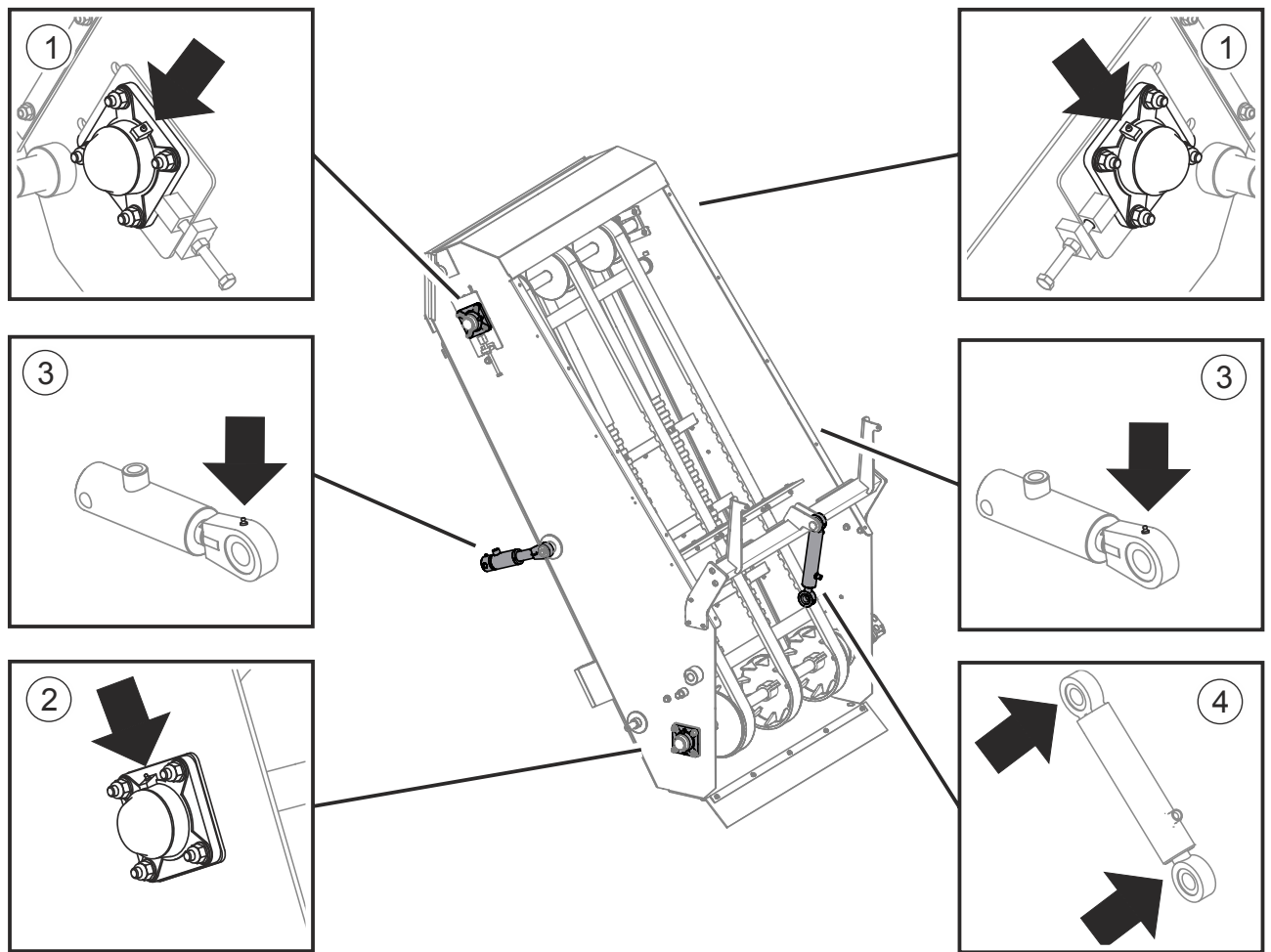

588-J.28-1

Figure 6.30 Conveyor lubrication

- (1) upper roller bearing (2) drive roller bearing (3) conveyor cylinder
 (4) roller brush lifting cylinder

Item	Name	Number of points	Type of lubricant	Frequency grease
1	Upper shaft bearing	2	grease	25 hours
2	Drive shaft bearing	1		
3	Conveyor cylinder	2		50 hours
4	Roller brush rising cylinder	2		

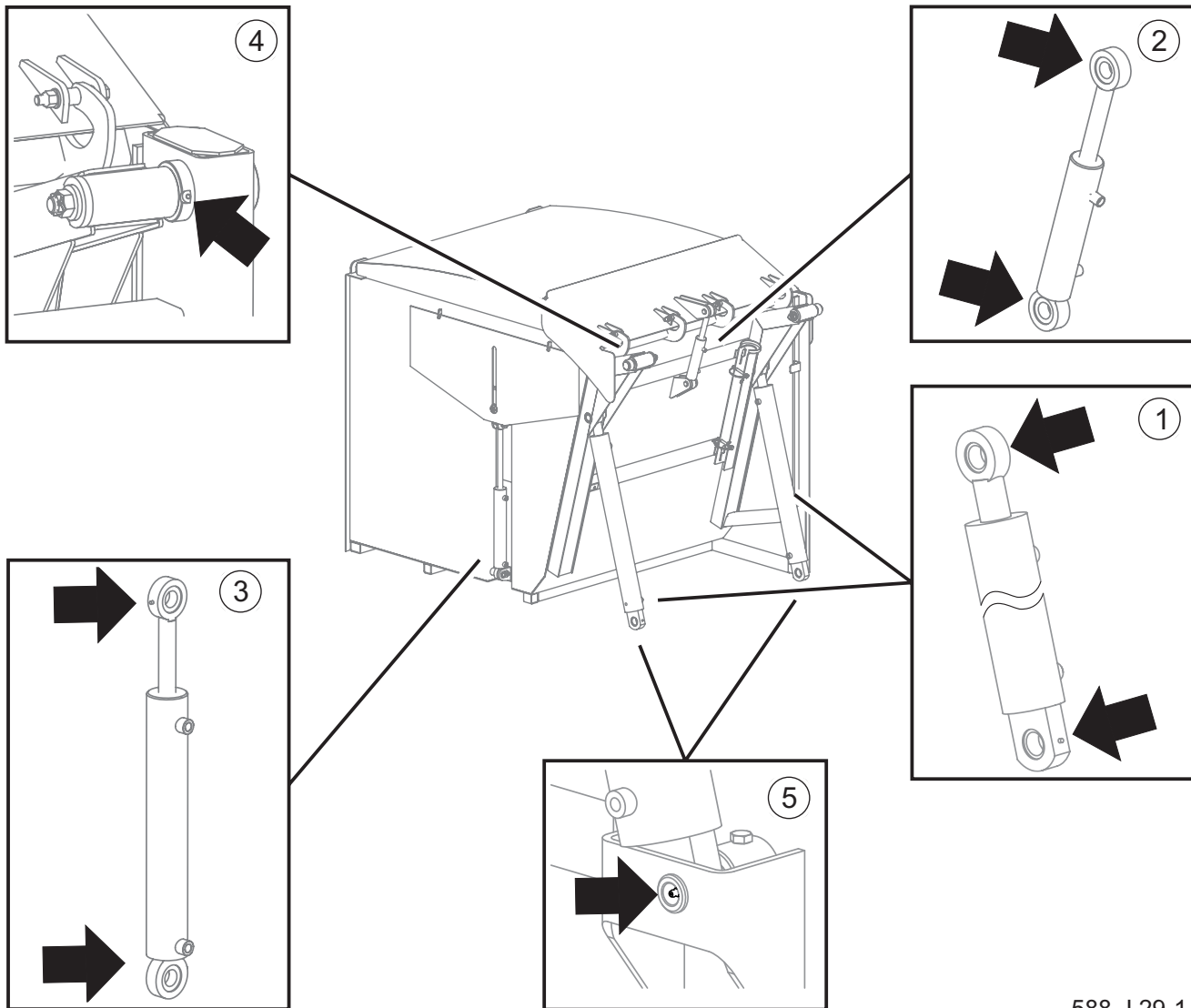

588-J.29-1

Figure 6.31 Lubrication of the container mechanism

(1) container tipping cylinder

(2) cover cylinder

(3) slide gate cylinder

(4) container tipping pin

(5) lower pin of the container tipping cylinder

Item	Name	Number of points	Type of lubricant	Frequency grease
1	Waste container tipping cylinder	4	grease	25 hours
2	Gate cylinder	2		
3	Slide gate cylinder	2		
4	Waste container tipping pin	2		
5	Lower pin of waste container tipping cylinder	2		

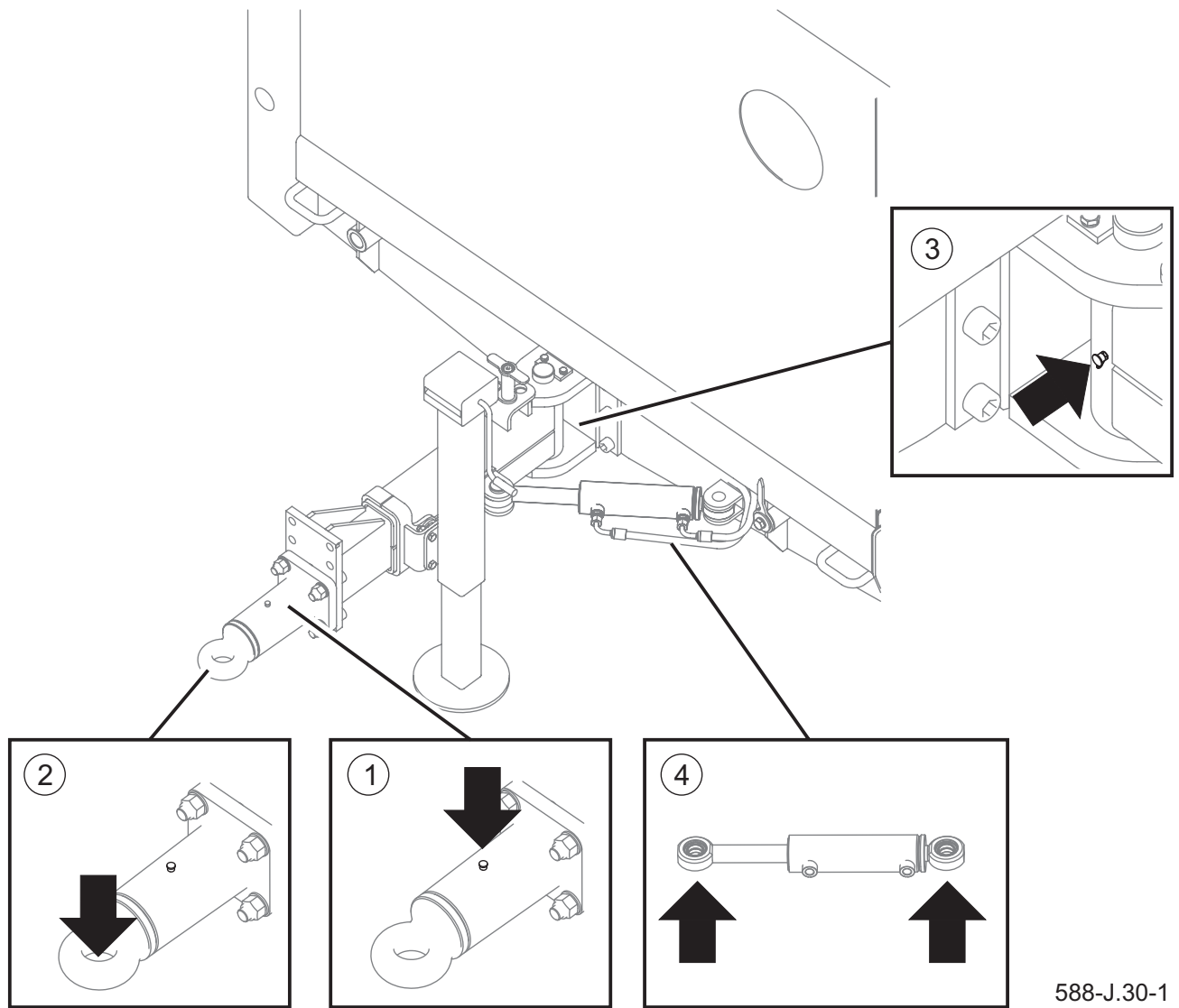

588-J.30-1

Figure 6.32 Lubricate the drawbar

- (1) drawbar eye rotation bushing (2) drawbar eye (3) drawbar swivel sleeve
 (4) drawbar swivel cylinder

Item	Name	Number of points	Type of lubricant	Frequency grease
1	Drawbar eye turning sleeve	1	grease	50 hours
2	Drawbar eye	1		
3	Drawbar turning sleeve	1		
4	Drawbar turning cylinder	2		

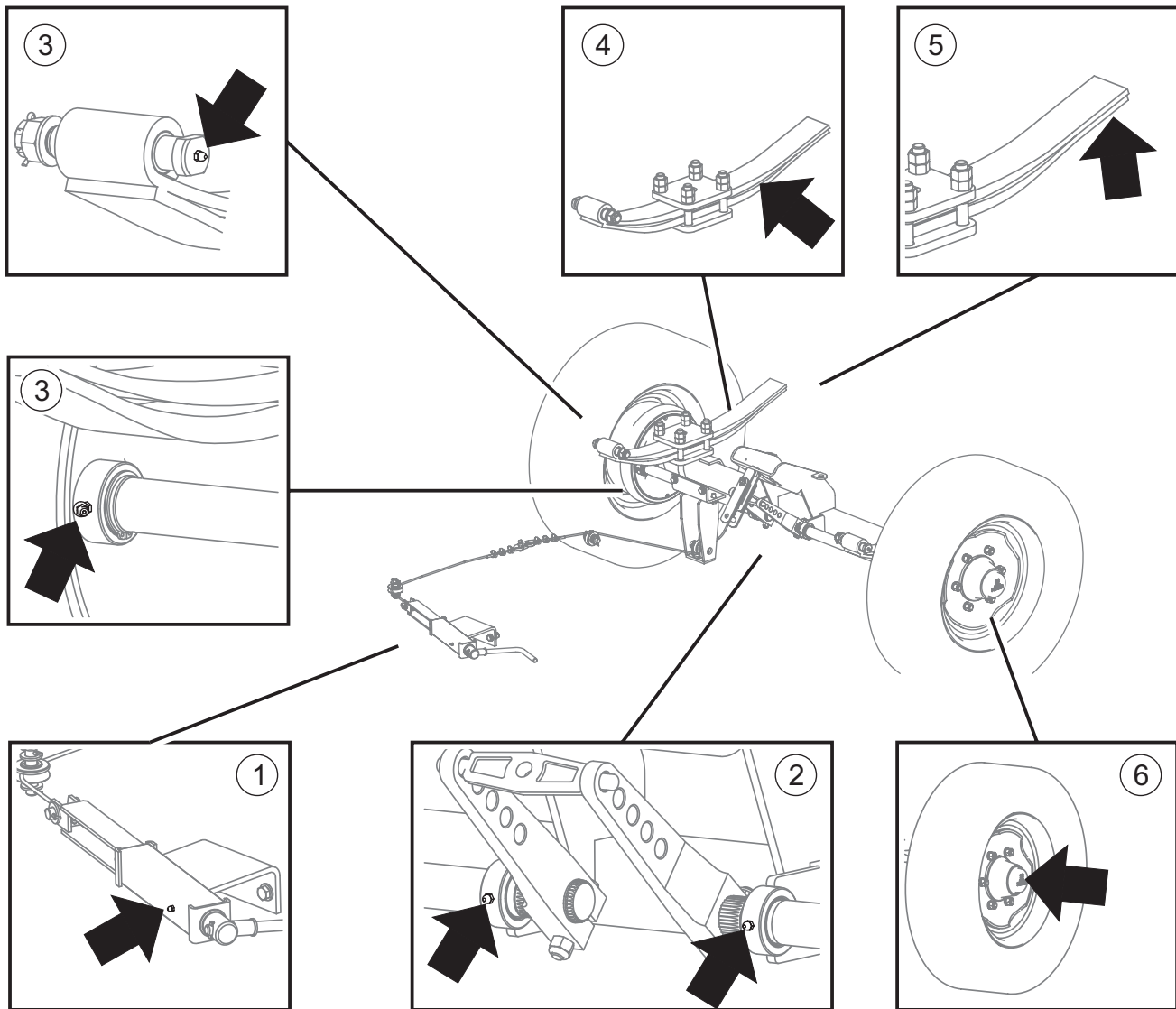

588-J.31-1

Figure 6.33 Lubricate brakes and axle system

(1) parking brake mechanism

(2) expander shaft bushings

(3) leaf spring absorber pin

(4) Leaf spring

(5) leaf spring sliding surface

(6) wheel bearings

Item	Name	Number of points	Type of lubricant	lubrication frequency
1	Parking brake mechanism	1	grease	6 months
2	Expander shaft sleeves	4		3 months
3	Leaf spring absorber pin	2		3 months
4	Leaf spring	2	anticorrosion preparation in aerosol	3 months
5	Spring sliding surface	2	grease	3 months
6	Wheel bearings	2		2 years

J.2.6.588.12.1.EN

6.13 CENTRAL LUBRICATION (OPTION)

The central lubrication system consists of the lubricating pump installed together with the grease tank and the main conduit supplying grease to individual receivers. The pump works cyclically according to the programmed intervals of pausing and grease pumping. The pump, through the eccentric shaft, moves the plunger of the pumping element that sucks grease in from the tank and then pumps it through the conduits to the manifolds located on the machine.

During operation, the pump must be perfectly clean. Small contaminations may cause damage to the pump and/or system components. Remember! If the tank has been emptied completely, it must work for

about 10 minutes after refilling to reach its full capacity. Clean the pump and the system components using only clean petrol.

Every day before starting the machine, check the fill level in the tank. If necessary, add grease.

Once a week, check whether grease is correctly supplied to the distributors and individual lubrication points.

The settings of the automatic lubrication pump are selected by the Manufacturer for specific working conditions of the machine and they must not be changed.

EP2 grease (NLGI2) should be used for the central lubrication system.

J.2.6.588.13.1.EN

6.14 STORAGE

After finishing work, machine should be thoroughly cleaned and washed with water jet. While washing do not direct a strong water jet at information and warning decals, bearings, hydraulic or pneumatic cylinders, electrical equipment. In the event of damage to the lacquer coating clean those places from rust and dirt, degrease and then paint with paint maintaining uniform colour and even thickness of protective coating. Until the time of touch-up painting, the damaged place may be covered with a thin layer of grease or anti-corrosion preparation. Tyres should undergo conservation maintenance at least twice a year using the appropriate preparations designed for this purpose. Wheels and tyres should be previously carefully washed and dried. During longer storage of unused machine it is recommended that every 2 to 3 weeks the machine may be moved a bit so that the place of contact of tyres with ground is changed.

It is recommended to keep the machine in a closed or roofed building.

If there is a risk that temperatures drop below 0°C, drain water from the spray system.



IMPORTANT

While washing do not direct a strong water or steam jet at information and warning decals, bearings, hydraulic lines or electrical wires.

TIP

Annually before the winter period unscrew and clean drain valve.

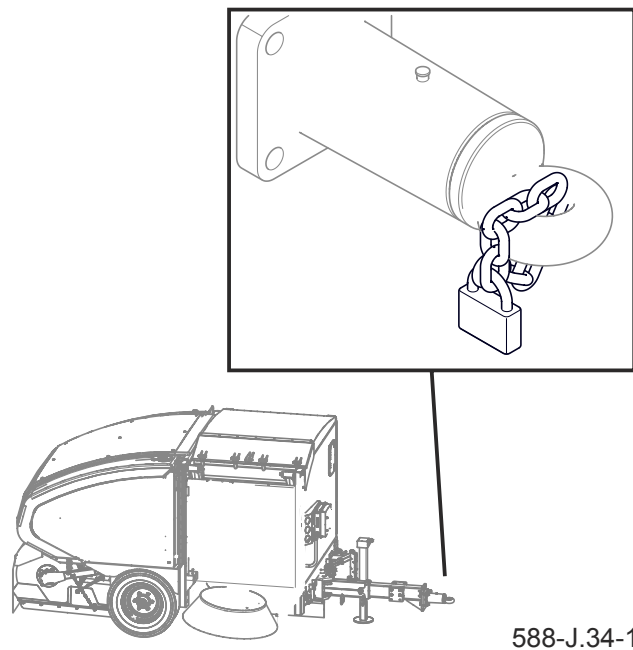

588-J.34-1

Figure 6.34 Protecting the machine from unauthorized use.

J.2.6.588.14.1.EN

6.15 TIGHTEN BOLT CONNECTIONS

During maintenance and repair work, confirm that all bolt connections are properly tightened. If any clearances in bolt connections are found, tighten bolt connections using appropriate tightening torque (TABLE 6.2), unless other tightening parameters are given. Recommended torque values apply to non-greased steel bolts.

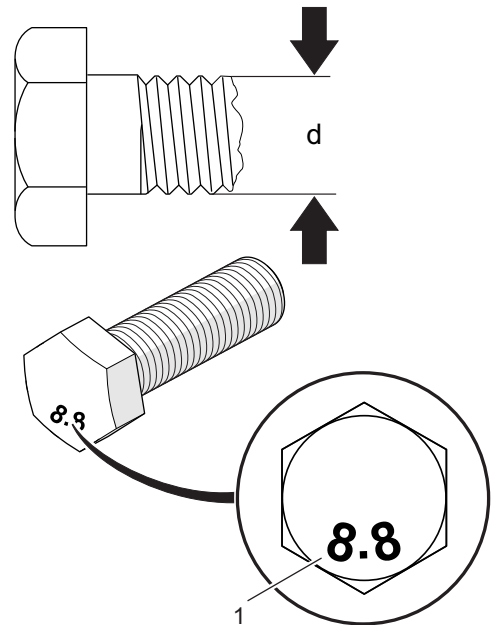

569-1.09-1

Figure 6.35 Bolt with metric thread

(1) resistance class (d) thread diameter

Table 6.2. Tightening torque for nut and bolt connections

THREAD MARKING [mm]	8.8	10.9
	TIGHTENING TORQUE [Nm]	
M6	10	15
M8	25	36
M10	49	72
M12	85	125
M14	135	200
M16	210	310
M20	425	610
M24	730	1,050
M27	1,150	1,650
M30	1,450	2,100
M32	1,450	2,100

I.2.5.28.05.1.EN

6.16 TROUBLESHOOTING

Table 6.3. Troubleshooting

Problem	Possible cause	Solution
Control panel does not work	Main switch of control panel is off	Set main switch of control panel in „I” position
	Electrical system power not connected	Check connection
	Control panel fuse blown	Change fuse
	Emergency Stop button pressed	Check the cause. Disable the emergency stop function.
High temperature of hydraulic oil	Fan does not work.	Check fan fuse
	Contaminated oil cooler.	Clean the radiator with compressed air
	Faulty temperature sensor	Replace
Low hydraulic oil level.	Loss of oil	Check the system for leaks. Add oil to proper level.
Sweeper does not collect waste precisely	Brush rotation speed too low	Increase brush rotation speed
	Driving too fast	Adapt the speed to the amount of contamination
	Brush incorrectly set.	Adjust the brushes according to the instructions
Too rapid wear of brushes	Brush incorrectly set.	Adjust the brushes according to the instructions
Excessive dustiness during machine operation	Spray system is not switched on	Turn on spray
	No water in the spray system tank	Add water, check water level during operation
	Clogged or shut down spray nozzles	Check for patency. Activate the desired spray nozzles
	Too low pressure at water pump	Set the correct pressure.

J.2.6.588.16.1.EN

