



PRONAR Sp. z o.o.

17-210 NAREW, UL. MICKIEWICZA 101A, WOJ. PODLASKIE

tel.:	+48 085 681 63 29	+48 085 681 64 29
	+48 085 681 63 81	+48 085 681 63 82
fax:	+48 085 681 63 83	+48 085 682 71 10

www.pronar.pl

OPERATOR'S MANUAL

DISC MOWER

PRONAR PDD830

PRONAR PDD830C

TRANSLATION OF THE ORIGINAL INSTRUCTIONS

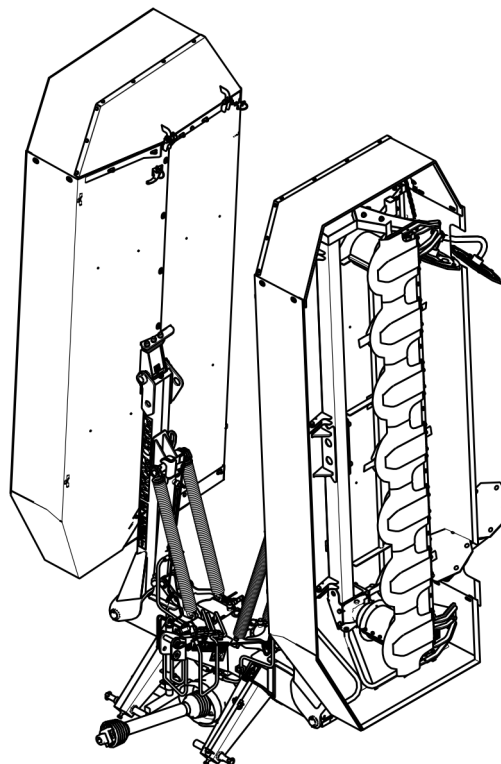

ISSUE 2A-03-2023

PUBLICATION NO 393N-00000000-UM



INTRODUCTION

Information contained herein is current at date of publication. As a result of improvements, some numerical values and illustrations contained in this publication may not correspond to the factual specification of the machine supplied to the user. The manufacturer reserves the right to introduce design changes in machines produced that facilitate operation and improve the quality of their work, without making minor amendments to this Operator's Manual.

This Operator's Manual is an integral part of the machine's documentation. Before using the machine, the user must carefully read this Operator's Manual and observe all recommendations. This guarantees safe operation and ensures malfunction free work of the machine. The machine is designed to meet obligatory standards, documents and legal regulations currently in force.

The manual describes the basic safety rules and operation of the Pronar PDD830 / PDD830C disc mower.

If the information stated in the Operator's Manual needs clarification then the user should refer for assistance to the sale point where the machine was purchased or to the Manufacturer.

MANUFACTURER'S ADDRESS:

*PRONAR Sp. z o.o.
ul. Mickiewicza 101A
17-210 Narew*

CONTACT TELEPHONES

<i>+48 085 681 63 29</i>	<i>+48 085 681 64 29</i>
<i>+48 085 681 63 81</i>	<i>+48 085 681 63 82</i>

SYMBOLS APPEARING IN THIS OPERATOR'S MANUAL

Information, descriptions of danger and precautions and also recommendations and prohibitions associated with user safety instructions are marked:



and also preceded by the word "**DANGER**". Failure to observe the instructions may endanger the machine operator's or other person's health or life.

Particularly important information and instructions, the observance of which is essential, are distinguished in the text by the sign:



and also preceded by the word "**ATTENTION**". Failure to observe the instructions may lead to damage to the machine as a result of improper operation, adjustment or use.

In order to focus the user's attention on the need to perform maintenance, the relevant section of the Operator's Manual is marked with the pictogram:



Additional tips and advice for machine operation are marked:



and also preceded by the word "**TIP**".

DIRECTIONS USED IN THIS OPERATOR'S MANUAL

Left side – side to the left hand of the operator facing in the direction of machine's forward travel.

Right side – side to the right hand of the operator facing in the direction of machine's forward travel.

REQUIRED SERVICE ACTIONS

Service actions described in the manual are marked: ➡

Result of service/adjustment actions or comments concerning the performance of actions are marked: ⇨



PRONAR Sp. z o.o.

ul. Mickiewicza 101 A

17-210 Narew, Polska

tel./fax (+48 85) 681 63 29, 681 63 81, 681 63 82,
681 63 84, 681 64 29

fax (+48 85) 681 63 83

<http://www.pronar.pl>

e-mail: pronar@pronar.pl

EC DECLARATION OF CONFORMITY OF THE MACHINERY

PRONAR Sp. z o.o. declares with full responsibility, that the machine:

Description and identification of the machinery		
Generic denomination and function:	Double-sided Disc Mower	
Type:	PDD830	PDD830C
Model:	–	–
Serial number:		
Commercial name:	Double-sided Disc Mower PRONAR PDD830 Double-sided Disc Mower PRONAR PDD830C	

to which this declaration relates, fulfills all the relevant provisions of the Directive **2006/42/EC** of The European Parliament and of The Council of 17 May 2006 on machinery, and amending Directive 95/16/EC (Official Journal of the EU, L 157/24 of 09.06.2006).

The person authorized to compile the technical file is the Head of Research and Development Department at PRONAR Sp. z o.o., 17-210 Narew, ul. Mickiewicza 101A, Poland.

This declaration relates exclusively to the machinery in the state in which it was placed on the market, and excludes components which are added and/or operations carried out subsequently by the final user.

Narew, the 2014-06-03

Place and date

Z-CIA DYREKTORA
d/s technicznych
członek zarządu
Roman Omelaniuk

*Full name of the empowered person
position, signature*

CONTENTS

1 BASIC INFORMATION	1.1
1.1 IDENTIFICATION	1.2
1.2 PROPER USE	1.3
1.3 EQUIPMENT	1.5
1.4 TERMS & CONDITIONS OF WARRANTY	1.6
1.5 TRANSPORT	1.7
1.6 ENVIRONMENTAL HAZARDS	1.10
1.7 WITHDRAWAL FROM USE	1.11
2 SAFETY ADVICE	2.1
2.1 BASIC SAFETY RULES	2.2
2.2 DRIVING ON PUBLIC ROADS	2.6
2.3 DESCRIPTION OF RESIDUAL RISK	2.6
2.4 INFORMATION AND WARNING DECALS	2.7
3 DESIGN AND OPERATION	3.1
3.1 TECHNICAL SPECIFICATION	3.2
3.2 GENERAL DESIGN	3.3
3.3 LINKAGE	3.4
3.4 DRIVE TRANSMISSION	3.4
3.5 CUTTING UNIT	3.5
3.6 HYDRAULIC SYSTEM	3.6
3.7 CONDITIONER (PDD830C)	3.8

4	CORRECT USE	4.1
4.1	PREPARING FOR WORK	4.2
4.2	CHECKING TECHNICAL CONDITION OF MOWER	4.4
4.3	HITCHING TO TRACTOR	4.5
4.4	TRANSPORTING THE MACHINE	4.8
4.5	SETTING AND MOWING	4.11
4.5.1	SETTING WORKING POSITION	4.11
4.5.2	CUTTING HEIGHT ADJUSTMENT	4.12
4.5.3	ADJUSTMENT OF CUTTERBAR PRESSURE	4.14
4.5.4	CONNECTING DRIVE SHAFT	4.15
4.5.5	SETTING THE SWATH WIDTH IN PDD830 MOWER	4.17
4.5.6	SETTING THE SWATH WIDTH IN PDD830C MOWER	4.18
4.5.7	SET THE CONDITIONING INTENSITY IN THE PDD830C MOWER	4.20
4.5.8	MOWING	4.21
4.6	DISCONNECTING FROM TRACTOR	4.24
4.7	LIGHTING INSTALLATION AND ADDITIONAL SIGNAGE	4.25
4.7.1	CONSTRUCTION	4.25
4.7.2	USE AND MAINTENANCE	4.26
5	MAINTENANCE	5.1
5.1	CHECKING AND REPLACING CUTTING BLADES AND PINS	5.2
5.2	INSPECT AND REPLACE SWATH CONDITIONER FLAIL BLADES (PDD830C)	5.4
5.3	DRIVE SYSTEM MAINTENANCE	5.6
5.3.1	OPERATE TRANSMISSION	5.6
5.3.2	PDD830C BELT DRIVE TENSION ADJUSTMENT	5.8
5.4	CUTTERBAR MAINTENANCE	5.9
5.5	HYDRAULIC SYSTEM OPERATION	5.12

5.6	LUBRICATION	5.14
5.7	STORAGE	5.17
5.8	TIGHTENING TORQUE FOR NUT AND BOLT CONNECTIONS	5.18
5.9	TROUBLESHOOTING	5.19

NOTES

SECTION

1

**BASIC
INFORMATION**

1.1 IDENTIFICATION

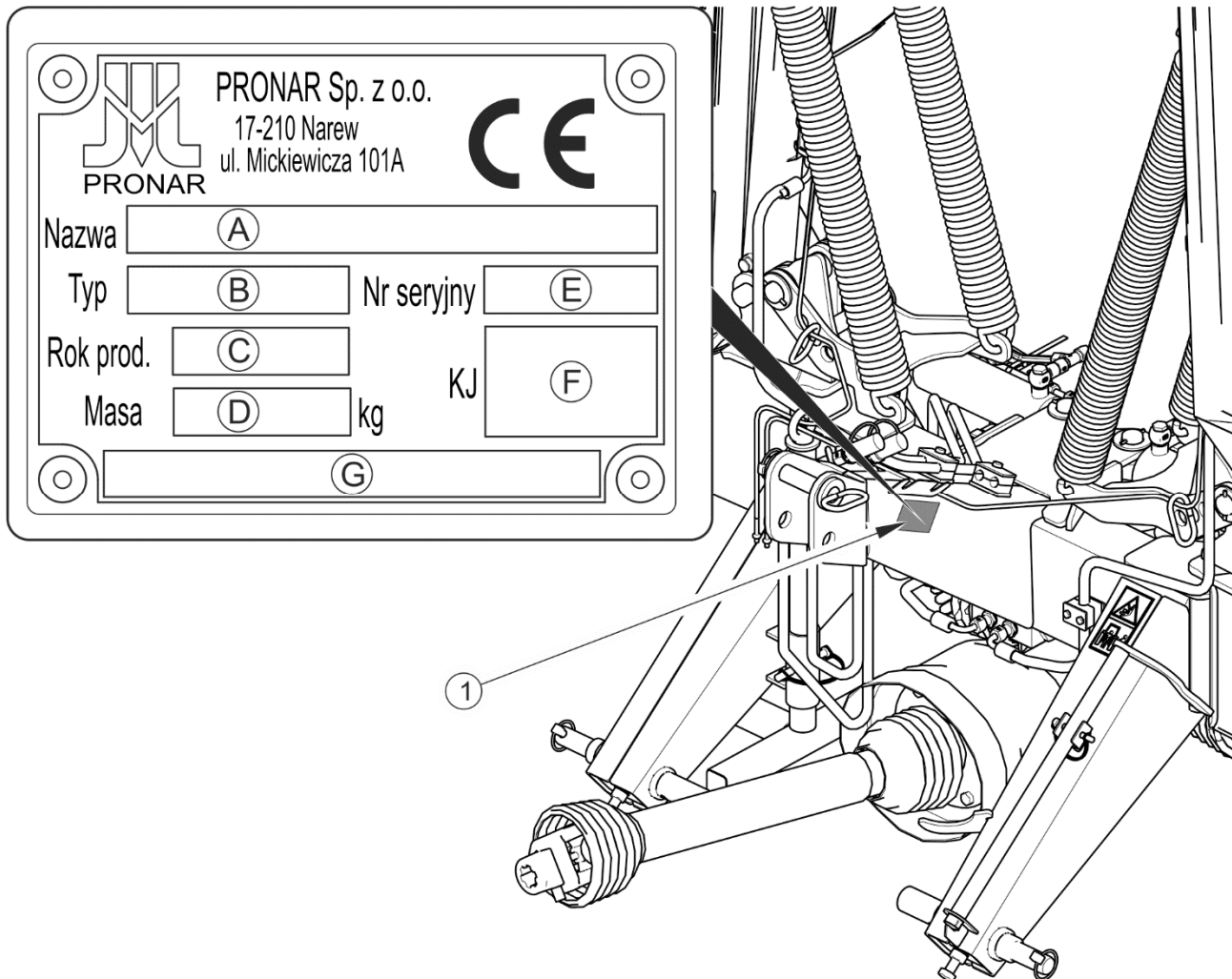

FIG. 1.1 Location of the data plate

(1) data plate

The disc mower combination has a data plate (1) located on the left side of the hitch. When buying the disc mower check that the serial numbers on the machine agree with the number written in the *WARRANTY BOOK*, in the sales documents and in the *OPERATOR'S MANUAL*

The meanings of the individual fields found on the data plate are presented in the table below:

TAB. 1.1 Markings on data plate

ITEM	MARKING
A	Machine name
B	Symbol /Type
C	Year of manufacture
D	Machine tare weight
E	Serial number
F	Quality Control marking
G	Unfilled box or extension of name (box A)

1.2 PROPER USE

The disc mower combination is a combined design of two disc mowers each with a working width of 3m, mounted on a joint three point linkage hitch frame. It is designed to work in combination with a front mounted mower with a working width of min 2.8 m. The mowing width of this combination is 8.3 m.

IMPORTANT



The mower must not be used for purposes other than those for which it is intended, in particular:

- for transporting people and animals,
- for transport of whatever materials or objects.

It is designed to cut grass and low stemmed green fodder on permanent grassland (marshes) and on stone free cultivated fields with a level surface. The mower is the basic machine for production of hay and silage. Do NOT use the machine for any other purpose. Using it as intended also involves all actions connected with the safe and proper operation and maintenance of the machine. Due to the above, the user is obliged to:

- carefully read this publication and the PTO shaft Operator's Manual and adhere to the recommendations contained in these documents,

- understand the machine's operating principle and how to operate it safely and correctly,
- comply with general safety regulations while working,
- prevent accidents,
- comply with road traffic regulations.

TAB. 1.2 Agricultural tractor's requirements

CONTENTS	UNIT	REQUIREMENTS
Linkage Rear three point linkage	-	Category II and III according to ISO 730-1
Hydraulic system Pressure rating of the system Hydraulic oil: Hydraulic sockets	MPa - -	16 AGROL U One double-acting section + one single-acting section with floating position
PTO drive PTO rotation direction PTO speed PTO shaft type	- RPM -	clockwise 1 000 type 1 according to ISO 500 (Ø 35 mm, 6 splines)
Other requirements Minimum power demand PDD830 PDD830C Tractor equipped with operator cabin	kW / Horsepower kW / Horsepower -	88 / 120* 110 / 150* YES

* - for combination with PDF300 front mower

Do NOT perform unauthorised repairs and modifications to the mower as this shall be treated by the Manufacturer as misusing the machine.

The machine may only be used by appropriately trained users, who are aware of the dangers, design and operation of the mower. Repairs to the machine shall only be made by

qualified personnel (in the warranty period all repairs must be performed in the warranty service, indicated by the Manufacturer). Maintenance and repairs that can be performed by the user, are described in section 5 „*MAINTENANCE*”.

1.3 EQUIPMENT

TAB. 1.3 PDD830/PDD830C mower equipment

Equipment	STANDARD	ADDITIONAL	OPTION
<i>OPERATOR'S MANUAL</i>	•		
<i>WARRANTY BOOK</i>	•		
PTO shaft with friction clutch and single right direction for connection with tractor.	•		
Electrical lighting installation			•
Document holder		•	
Distinguishing board TW-11			•

Recommended PTO shafts for connecting mowers with tractor:

- Comer T601010ENC12RF6
- B&P 7 10 6 101 CE 007 2F2
- Weasler 1611-6600-101-05

Recommended shaft connecting mower bevel transmissions:

- Weasler 904-01507

1.4 TERMS & CONDITIONS OF WARRANTY

PRONAR Sp. z o.o. Narew guarantees the reliable operation of the machine when it is used according to its intended purpose as described in the *OPERATOR'S MANUAL*. The repair period is specified in the *WARRANTY BOOK*.

The warranty does not apply to those parts and sub-assemblies of the machine, which are subject to wear in normal usage conditions, regardless of the warranty period. Consumables include the following parts/sub-assemblies:

- working discs,
- slides
- transmissions and their components,
- protective aprons,
- cutting blades, flail blades,
- pins securing cutting blades,
- bearings, slide bushings,
- swath guide rubber,
- rubber-metal shock absorbers,
- V belts,
- fasteners.

The warranty service only applies to factory defects and mechanical damage that is not due to the user's fault.

In the event of damage arising from:

- mechanical damage which is the user's fault, caused by road accidents,
- by inappropriate use, adjustment or maintenance, use of the mower for purposes other than those for which it is intended,
- use of damaged machine,
- repairs carried out by unauthorised persons, improperly carried out repairs,
- making unauthorised alterations to machine design,

the user will lose the right to warranty service.

**TIP**

Demand that the seller carefully and precisely fills out the Warranty Book and warranty repair coupons. A missing date of purchase or sale point stamp, may make the user ineligible for any warranty repair or refund.

The user is obliged to report immediately on noticing any wear in the paint coating or traces of corrosion, and to have the faults rectified whether they are covered by the warranty or not. For detailed Terms & Conditions of Warranty, please refer to the *WARRANTY BOOK* attached to each machine.

Modification of the machine without the written consent of the Manufacturer is forbidden. In particular, do NOT weld, drill holes in, cut or heat the main structural elements of the machine, which have a direct impact on the machine operation safety.

1.5 TRANSPORT

The machine is prepared for sale completely assembled and does not require packing.. Packing is only required for the machine operator's manual and elastic covers.

The mower may be moved to another place by transport vehicle on load platform, or independently transported mounted on agricultural tractor using the three point linkage. During independent transport by road the mower should always be set in transport position properly secured - see section 4.4 "*TRANSPORTING THE MACHINE*". Comply with the regulations of the traffic regulations concerning lights and indicators.

When loading and unloading the mower on other vehicles for transport, comply with the general principles of workplace health and safety for reloading work. Persons operating reloading equipment must have the qualifications required to operate these machines. Only use lifting equipment with a lifting capacity greater than the weight of the mower given on the data plate. This also applies to cables, belts and chains used during reloading.

ATTENTION

When transporting independently, the user must carefully read this operator's manual and observe its recommendations. When being transported on a motor vehicle the mower must be mounted on the vehicle's platform in accordance with the transport safety requirements. The driver of the vehicle should take particular care while driving.

During loading mower should be set in working position and secured. Support leg should be lowered and secured with a pin.

The machine should be attached firmly to the platform of the vehicle using straps or chains fitted with a tightening mechanism. The fastening equipment used must have a valid safety certificate. During reloading work, particular care should be taken not to damage parts of the mower's fittings or the paint coat.

DANGER

Nobody may be in the manoeuvring zone during transferring mower to other form of transport.

The machine should be attached to lifting equipment in places intended for this - figure (1.2), i.e. transport lug (1) and central connection pin (2). When lifting the mower take particular care due to the possibility of tipping over the machine and the risk of injuries from protruding parts. To keep machine in the correct direction it is recommended to apply additional guy cables. During the loading work particular care should be taken not to damage paint coating.

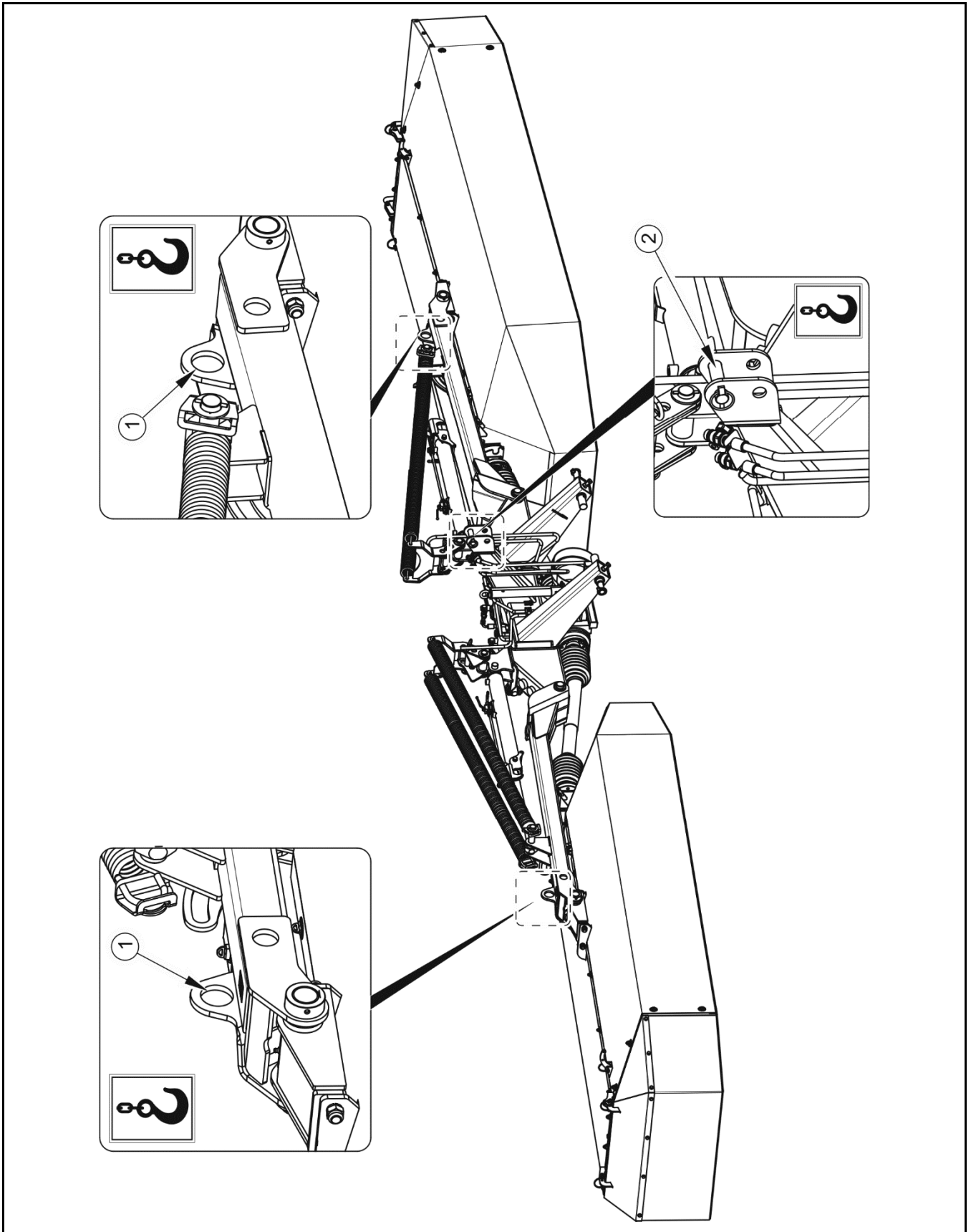

FIG. 1.2 Mower suspension points

(1) transport lug, (2) central connection pin

1.6 ENVIRONMENTAL HAZARDS

A hydraulic oil leak constitutes a direct threat to the natural environment owing to its limited biodegradability. The negligible solubility of hydraulic oil in water does not cause extreme toxicity of organisms living in the aquatic environment. The formation of a film of oil on the water may be the direct cause of physical action on organism, perhaps causing change of oxygen values in the water because of lack of direct contact of air with the water. An oil leak into water reservoirs may however lead to a reduction of the oxygen content.

While carrying out maintenance and repair work, which involves the risk of an oil leak, this work should take place on an oil resistant floor or surface. In the event of oil leaking into the environment, first of all contain the source of the leak, and then collect the leaked oil using available means. Remaining oil should be collected using sorbents, or by mixing the oil with sand, sawdust or other absorbent materials. The oil pollution, once gathered up, should be kept in a sealed, marked, hydrocarbon resistant container. The container should be kept away from heat sources, flammable materials and food.



DANGER

Used hydraulic oil or gathered remains mixed with absorbent material should be stored in a precisely marked container. Do not use food packaging for this purpose.

Oil, which has been used up or is unsuitable for further use owing to a loss of its properties should be stored in its original packaging in the conditions described above. Waste oil should be taken to the appropriate facility dealing with the re-use of this type of waste. Waste code: 13 01 10. Detailed information concerning hydraulic oil may be found on the product's Material Safety Data Sheet.



TIP

The hydraulic system of the mower is filled with AGROL U hydraulic oil.



IMPORTANT

Waste oil should only be taken to the appropriate facility dealing with the re-use of this type of waste. Do NOT throw or pour oil into sewerage or water tanks.

1.7 WITHDRAWAL FROM USE



DANGER

During dismantling, use the appropriate tools, equipment (overhead travelling crane, crane or hoist etc.) and use personal protection equipment, i.e. protective clothing, footwear, gloves and eye protection etc.

Avoid contact of skin with oil. Do not allow used hydraulic oil to spill.

In the event of decision by the user to withdraw the machine from use, comply with the regulations in force in the given country concerning withdrawal from use and recycling of machines withdrawn from use. Before proceeding to dismantle the machine, oil shall be completely removed from hydraulic system, cutter bar, and both intersecting axis gears. Locations of drain plugs and method for draining oil are described in section 5.

When spare parts are changed, worn out or damaged parts that cannot be reclaimed should be taken to a collection point for recyclable raw materials. Hydraulic oil should be taken to the appropriate facility dealing with the re-use of this type of waste.

SECTION

2

SAFETY ADVICE

2.1 BASIC SAFETY RULES

- Before using the mower the user should carefully read this Operator's Manual and the PTO shaft Operator's Manual and adhere to the recommendations contained in these documents.
- The mower may only be used and operated by persons qualified to drive agricultural tractors and trained in the use of the machine.
- If the information stated in the Operator's Manual is difficult to understand, contact a seller who runs an authorised technical service on behalf of the Manufacturer, or contact the Manufacturer directly.
- Careless and improper use and operation of the mower, and non-compliance with the recommendations given in this operator's manual is dangerous to your health.
- Be aware of the existence of a residual risk, and for this reason the fundamental basis for using this machine should be the application of safety rules and sensible behaviour.
- The machine must never be used by persons, who are not authorised to drive agricultural tractors, including children and people under the influence of alcohol or other drugs.
- Non-compliance with the safety rules of this Operator's Manual can be dangerous to the health and life of the operator and others.
- The mower must not be used for purposes other than those for which it is intended. Anyone who uses the machine in any other way than the way intended takes full responsibility for any consequences of this use.
- Any modification to the machine frees the manufacturer from any responsibility for damage or detriment to health which may arise as a result.
- Before using the machine always check its technical condition. In particular check the technical condition of the mounting hitch system, cutting system, correct mounting of cutting blades and protective guards.

- The machine may only be used when all the safety guards and other protective elements are technically sound and correctly positioned. In the event of loss or destruction of the safety guards, they must be replaced with new ones.
- The machine must not be used when not in working order.
- Before hitching the machine to the tractor, check the technical condition of the hitching system of the mower and the tractor.
- Be especially careful when hitching the machine to the tractor or truck tractor.
- When hitching, there must be nobody between the mower and the tractor.
- To attach the machine to the tractor only the rear three point linkage may be used. After mounting the machine, check the safeguards.
- To mount machine on tractor use only genuine pins and safeguard cotter pins.
- When connecting the hydraulic lines, make sure that the hydraulic system is not under pressure.
- The mower may only be connected to the tractor by appropriately selected PTO shaft recommended by the Manufacturer.
- The PTO shaft has markings on the casing, indicating, which end of the shaft shall be connected to the tractor.
- The chains preventing the shaft cover from turning while the shaft is working, shall be secured to a fixed element of mower's structure.
- Do NOT use the securing chains to support the shaft while machine is parked or when transporting the mower.
- Before using the machine the user should thoroughly acquaint himself with the PTO shaft Operator's Manual and adhere to the recommendations contained in it.
- The drive shaft must be equipped with a cover. Do NOT use the shaft with damaged or missing guards.
- Never use a damaged PTO shaft, it may cause an accident. A damaged shaft must be repaired or replaced.
- After connecting shaft ensure that it is correctly and safely connected to the tractor and to the mower.

- Before starting PTO shaft make certain that the PTO rotation direction is correct.
- Disconnect the drive shaft each time when it is not necessary to drive the machine, or when the tractor and mower are at an unsuitable angle to each other.
- Do NOT go over and under the shaft or stand on it equally during work as also when the machine is parked.
- Do NOT wear loose clothing, straps or whatever that may become wrapped round the rotating drive shaft. Contact with rotating PTO shaft may cause severe injuries.
- The mower may not be used or transported in conditions of limited visibility.
- When transporting mower mounted on tractor the hydraulic cylinder valves must be closed.
- Before lowering or raising mower on three point linkage make certain that nobody is near the machine and that nobody is operating it.
- Before starting the mower make sure that there are no bystanders (especially children) or animals in the danger zone. The machine operator is obliged to ensure proper visibility of the machine and the working area.
- Before starting PTO shaft the cutting unit must be in working position.
- Mowing should begin after reaching nominal PTO RPM (1000 rpm). Do NOT overload shaft and mower and also engage the clutch suddenly.
- During cutting do NOT use PTO revolution speed greater than 1000 rpm.
- When mowing on the edges of streets, public roads, on stony ground there is a risk that thrown out stones and foreign bodies may constitute a danger to third persons.
- Do NOT leave the tractor cab, when the machine drive is engaged.
- Do NOT approach cutting unit guards until the rotating cutting parts come to a complete standstill.
- Do NOT operate mower while reversing. While reversing raise the multifunction arm.
- Before disconnecting the shaft, turn off the tractor engine and remove the key from the ignition.
- Reduce pressure prior to disconnecting the hydraulic system.

- Mower uncoupled from tractor must be supported with the aid of supports and properly secured against tipping over.
- Do NOT ride on the mower or transport any materials on it.
- When operating the machine wear protective gloves and use the appropriate tools.
- Repair, maintenance and cleaning work should be carried out only after previously:
 - disconnecting drive transmission shaft,
 - switching off tractor engine,
 - applying handbrake,
 - removing the ignition key from ignition switch.
- Regularly check the condition of the bolt and nut connections.
- Regularly check the technical condition of the connections and the hydraulic lines. There must not be any leaks of hydraulic oil.
- During the warranty period, any repairs may only be carried out by Warranty Service authorised by the manufacturer.
- In the event of any fault or damage whatsoever, do not use the mower until the fault has been corrected. The machine must not be used when not in working order.
- Repair work should be carried out by persons trained and entitled to do so. This work should be carried out using appropriate tools.
- Should it be necessary to change individual parts, use only those parts indicated by the Manufacturer. Non-adherence to these requirements may put the user and other people's health and life at risk, and also damage the machine.
- In the event of work requiring the mower to be raised, use properly certified hydraulic or mechanical lifts for this purpose. After lifting the machine, stable and durable supports must also be used. Do NOT carry out work under a machine, which has only been raised with the lift jack.
- The machine must not be supported using fragile elements (bricks or concrete blocks).
- The paint coating should be cleaned off before beginning welding work. Burning paint fumes are poisonous for people and animals. Welding work should be carried out in a well lit and well ventilated space.

- During welding work pay attention to flammable or fusible elements. If there is a risk that they will catch fire or be damaged, they should be removed or covered with non-flammable material before commencing welding work. The mower must be disconnected from the tractor before commencing electric welding.
- Servicing and repair work should be carried out in line with the general principles of workplace health and safety. In the event of injury, the wound must be immediately cleaned and disinfected. In the event of more serious injuries, seek a doctor's advice.
- After finishing servicing or repair work remove all tools from the machine.
- Damaged, missing or worn cutting blades must be replaced in pairs in order to maintain the balance of the cutting disc.
- In order to reduce the danger of fire the machine must be kept in a clean condition.
- In order to limit occupational risks associated with exposure to noise during mower operation use individual protection (ear protectors).

2.2 DRIVING ON PUBLIC ROADS

- When driving on public roads, comply with the road traffic regulations.
- Do not exceed the maximum speed when travelling. Adjust driving speed to the road conditions.
- Before beginning travel, the mower must be placed in transport position and raised using the rear three-point linkage system. When parked, the mower should be lowered.
- During transport disconnect PTO shaft from tractor.
- Do NOT leave tractor driver's seat when the tractor is moving.

2.3 DESCRIPTION OF RESIDUAL RISK

Pronar Sp. z o. o. in Narew has made every effort to eliminate the risk of accidents. There is, however, a certain residual risk, which could lead to an accident, and this is connected mainly with the actions described below:

- using the snow plough for purposes other than those for which it is intended,

- being between the tractor and the mower while the engine is running and when the machine is being attached,
- operating the machine with removed or faulty safety guards,
- being on the machine while the engine is running,
- not maintaining safe distance from the danger zone or being within the zones while the machine is operating,
- operation of the machine by persons under the influence of alcohol;
- cleaning, maintenance and technical checks when tractor engine is running;
- making modifications to the machine without the consent of the Manufacturer,
- oil leaks and sudden movement of elements resulting from line cracking,
- using unreliable PTO shaft.

The residual risk may be kept to a minimum by following the recommendations below:

- prudent and unhurried operation of the machine,
- sensible adherence to the remarks and recommendations stated in the Operator's Manual,
- maintaining a safe distance from forbidden or dangerous places,
- a ban on being on the machine when it is operating,
- carrying out repair and maintenance work in line with operating safety rules,
- carrying out repair and maintenance work by persons trained to do so,
- using close fitting protective clothing,
- ensuring unauthorised persons have no access to the machine, especially children.





2.4 INFORMATION AND WARNING DECALS



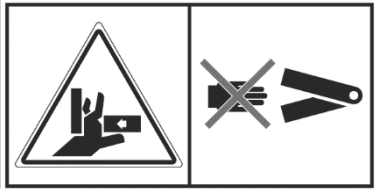

The mower is labelled with the information and warning decals mentioned in table (2.1). The symbols are positioned as presented in figure (2.1). Throughout the time it is in use, the user of the machine is obliged to take care that notices and warning and information symbols located on the mower are clear and legible. In the event of their destruction, they must be replaced with new ones. Safety decals are available from your PRONAR dealer or directly

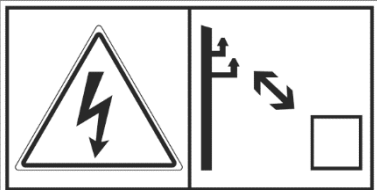

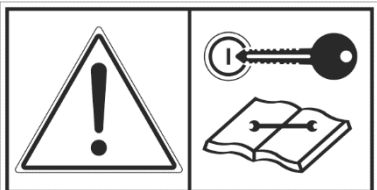

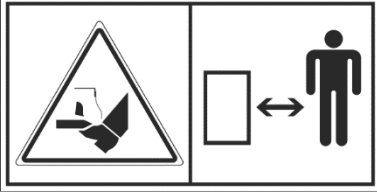
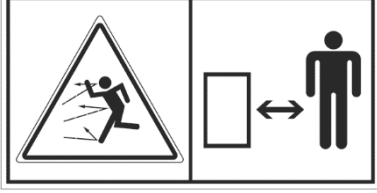

from PRONAR customer service. New assemblies, changed during repair, must be labelled once again with the appropriate safety signs.

Safety During cleaning do not use solvents, which may damage label covering and do not direct strong water jet at machine.

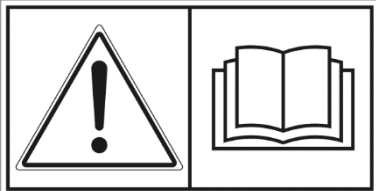
TAB. 2.1 Information and warning decals

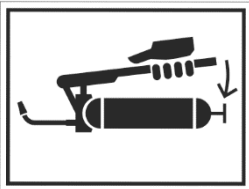
ITEM	DECAL	MEANING
1		Machine type. (PDD830)
2		Danger of crushing or severing of limbs. Be careful while folding and unfolding lateral guards.
3		Do NOT touch elements of the machine until the assembly has come to a standstill.
4		Keep a safe distance from electric power lines.
5		Maximum allowable PTO shaft rotation speed is 1000 rpm.
6		Before beginning servicing or repairs, turn off engine and remove key from ignition.

ITEM	DECAL	MEANING
7		<p>Danger associated with the rotating PTO shaft.</p>
8		<p>Warning- cutting blades do not approach an operating mower.</p>
9		<p>Risk of injury to foot or leg. Keep a safe distance.</p>
10		<p>Thrown out objects endanger the whole body. Keep a safe distance from the operating machine.</p>
11		<p>Danger caused by setting mower in working or transport positions.</p>
12		<p>Do NOT stand near lifting linkages during lifting or lowering.</p>

ITEM	DECAL	MEANING
13		Transport lug points marking.
14		Before starting work, carefully read the Operator's Manual
15		Correct setting of working position of mower.
16		Lubrication points.
17		Machine type. (PDD830C)
18		Note – belt drive. Exercise particular caution. (PDD830C)
19		Caution! Rotor Exercise particular caution. (PDD830C)

Numbers in the item column correspond to decals (figure 2.1; figure 2.2)

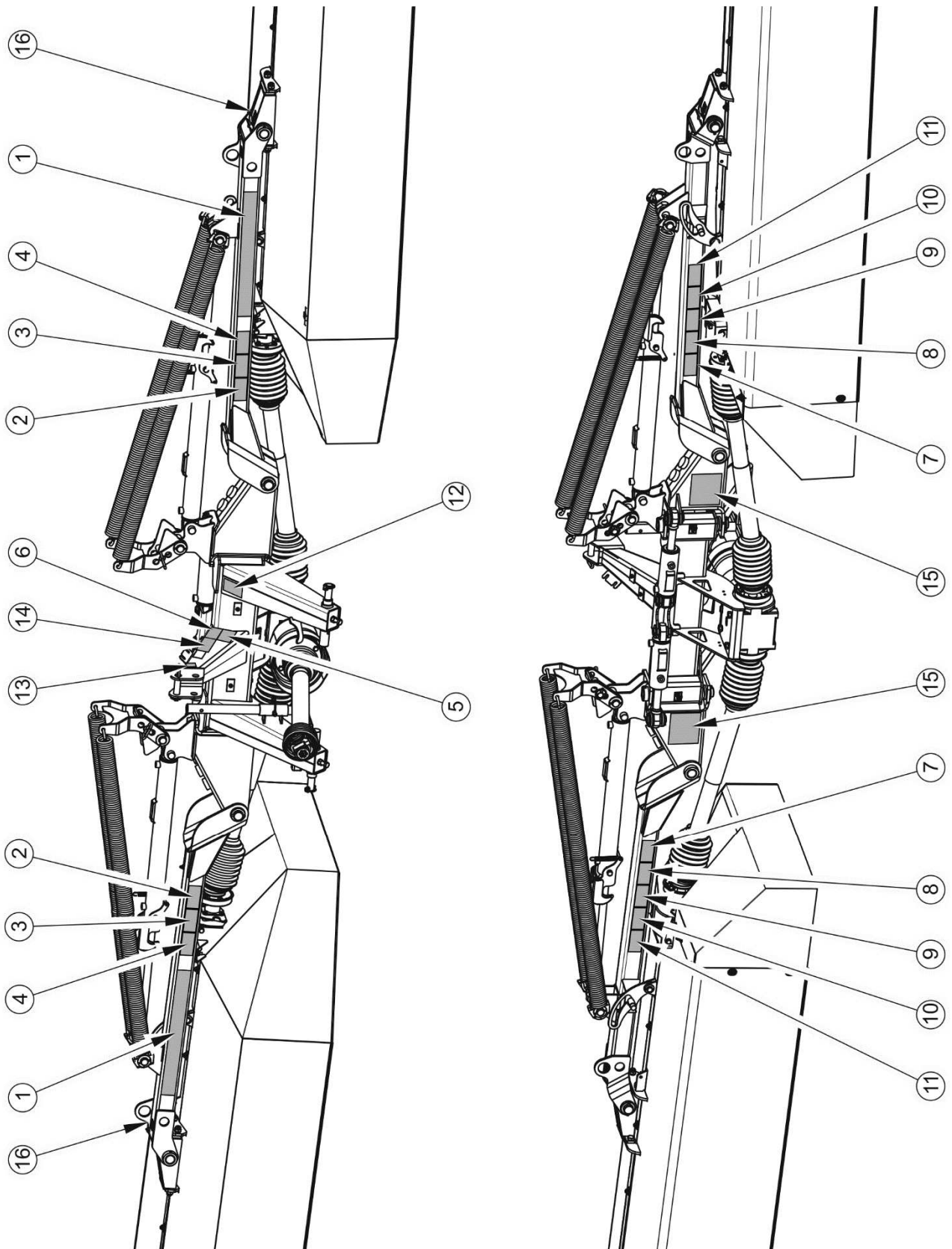

FIG. 2.1 Locations of PDD830/ PDD830C information and warning decals.

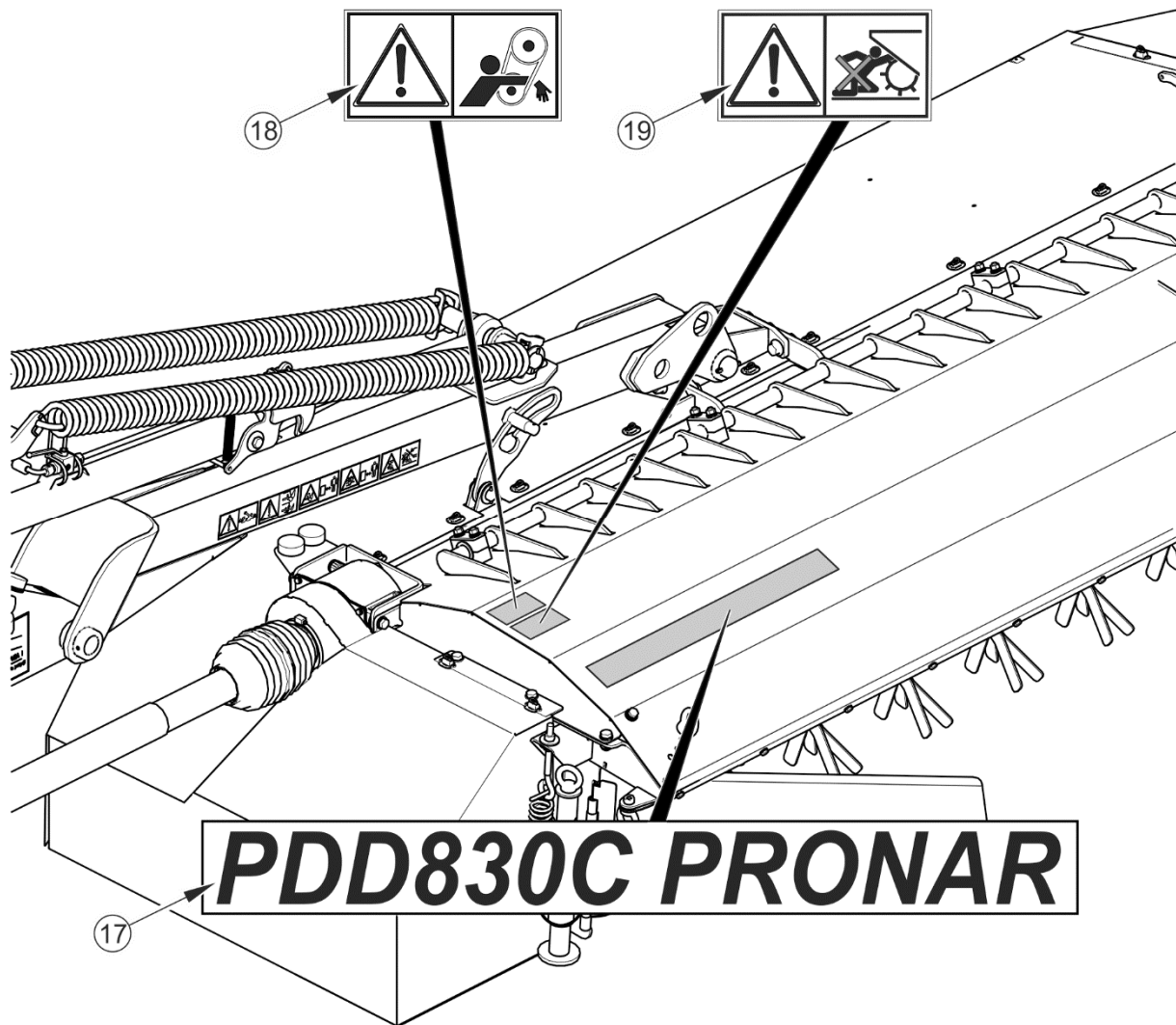

FIG. 2.2 Locations of PDD830C information and warning decals.

SECTION

3

**DESIGN AND
OPERATION**

3.1 TECHNICAL SPECIFICATION

TAB. 3.1 Basic technical specification

CONTENTS	UNIT	DATA	
		PDD830	PDD830C
Dimensions			
Total width in working setting	mm	8 880	
Total height in working setting	mm	1 310	
Width in transport setting	mm	2 600	
Height in transport position with the folded cover	mm	3 950	
Clearance from the ground in transport position	mm	200	
Total length in working and transport position	mm	1 540	
Technical specification			
Cutting width	mm	8 300★	
Work output	ha/h	8★	
Minimum tractor power demand	kW / Horsepower	88 / 120★	110 / 150★
Tare weight	kg	1 390	1 890
Maximum PTO speed	RPM	1 000	
Driveshaft torque	Nm	1 400	
Linkage	-	II and III according to ISO 730-1	
Number of discs	item	2x7	
Number of cutting blades	item	2x14	
Rotation speed of discs	RPM	3 000	
Surface tracking	degrees	+ 18 - 16	
Swath width min / max	mm	2 x (1200 / 2000)	2 x (1500 / 2300)
Overlapping of mown areas	mm	350★	
Recommended working speed	km/h	10	
Noise emission level:			
L_{WA}	dB	92.9	

★ for combination with PDF300 front mower

3.2 GENERAL DESIGN

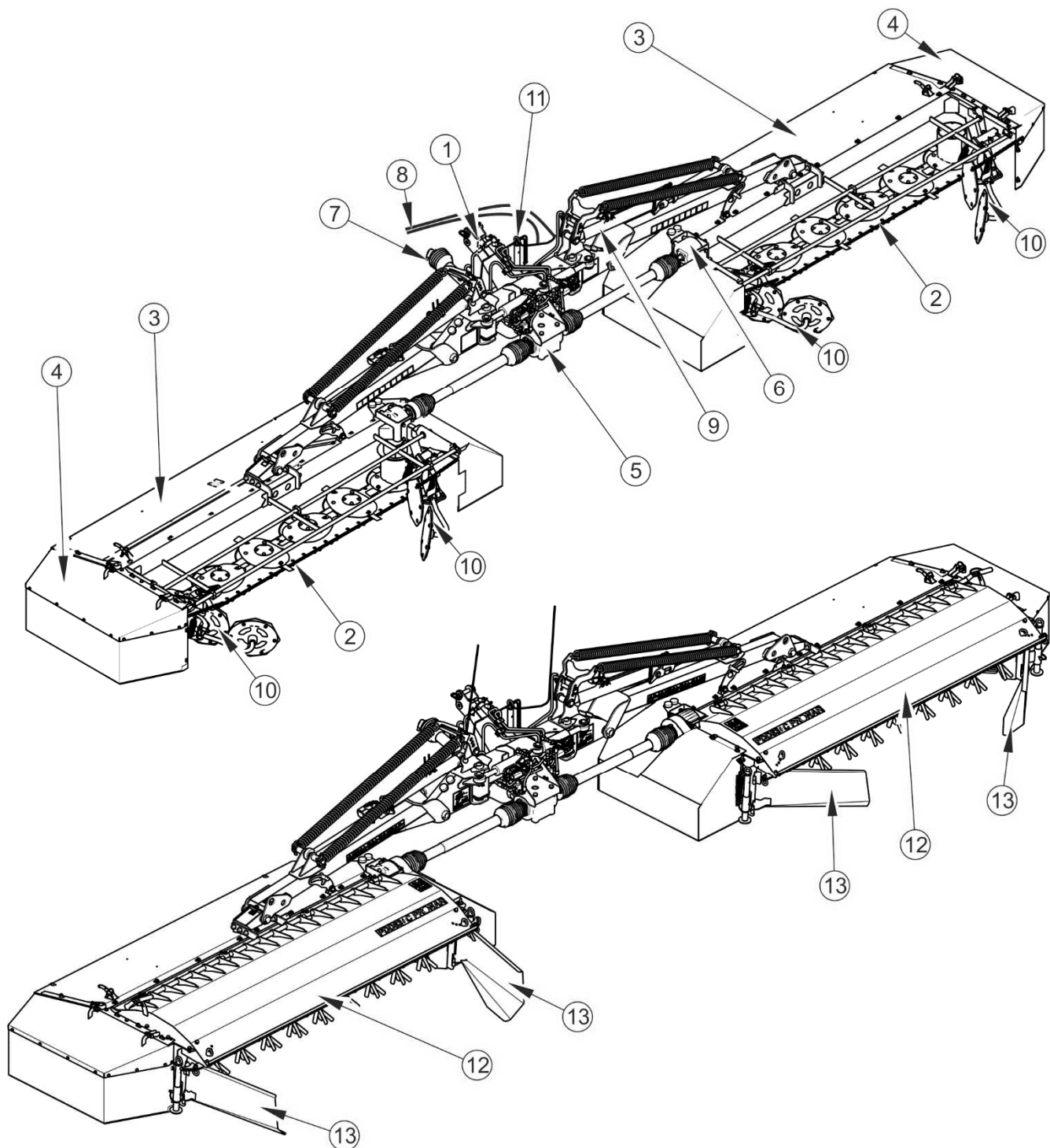

FIG. 3.1 PDD830 general design

(1) linkage frame, (2) cutting unit, (3) main frame, (4) side guard, (5) central transmission, (6) intersecting axis gear, (7) PTO shaft for connection with tractor, (8) interlock cable, (9) hydraulic system, (10) swath guide (PDD830), (11) support leg, (12) swath conditioner (PDD830C), (13) swath guide (PDD830C)

3.3 LINKAGE

The main element of the PDD830 / PDD830C mower linkage (figure 3.2) is the linkage frame (1), equipped with two lower pins (2) and upper pin (3) for connection to the tractor's three point linkage. Moving arm (4) allow the cutting unit to swing backwards at the moment of collision with obstacle. Lifting arms (5) raise the cutting unit. To ensure correct pressure of cutter bar on the surface, the machine is equipped with strong stay springs (6). The spring tension is adjusted by changing the position of the spring catch (7). The spring tension is adjusted by changing the position of the spring catch (7).

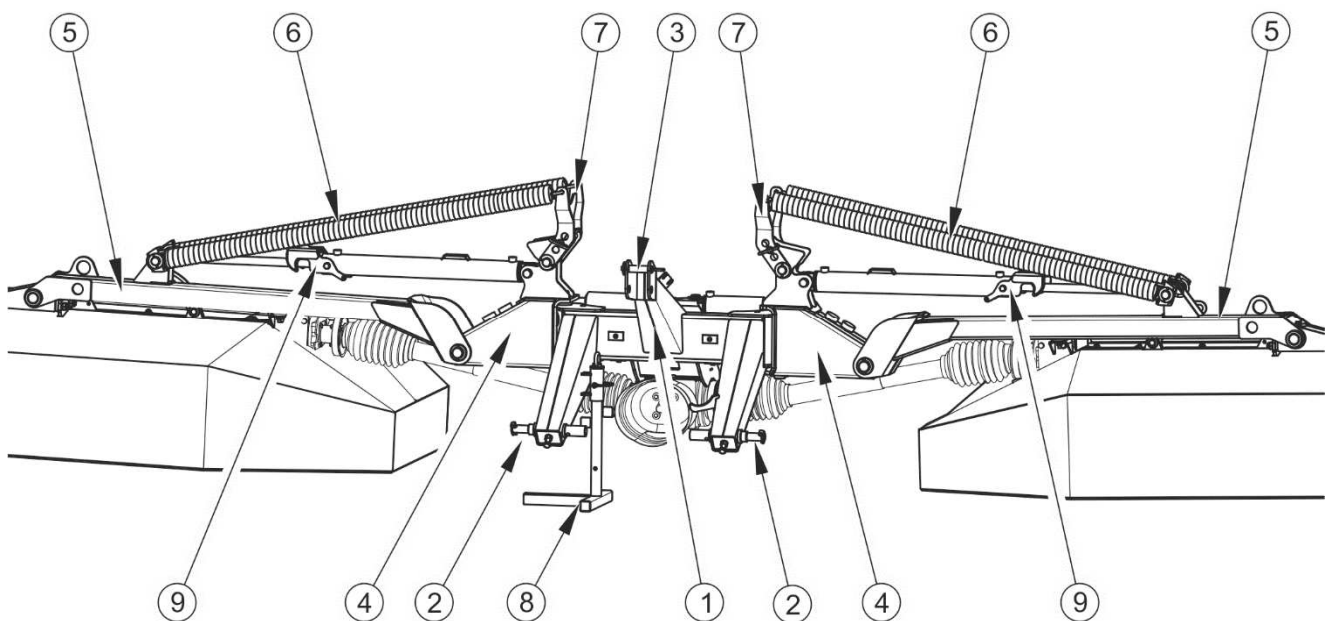

FIG. 3.2 Linkage

(1) linkage frame, (2) lower hitching eye pin, (3) central connection pin, (4) moving arm, (5) lifting arm, (6) stay springs, (7) spring catch, (8) support leg, (9) hydraulics cylinder catch

3.4 DRIVE TRANSMISSION

The mower is designed to work with PTO speed 1000 rpm and it is suitable for connection to tractors with PTO shaft revs turning clockwise when seen from rear of tractor.

Torque from the power take-off (PTO) shaft of the tractor is transferred by an articulated telescopic shaft (3) with a friction backstop clutch and the main mower transmission (1). Through shafts (4) torque from the main transmission is transferred to cutter bar (2) gears, and then through a double articulated connector (6) to cutter bar (5). In the version of the

PDD830C mower with swath conditioner, the conditioner is driven by intersecting axis gear (2) through belt transmission (6) with tensioner (7).

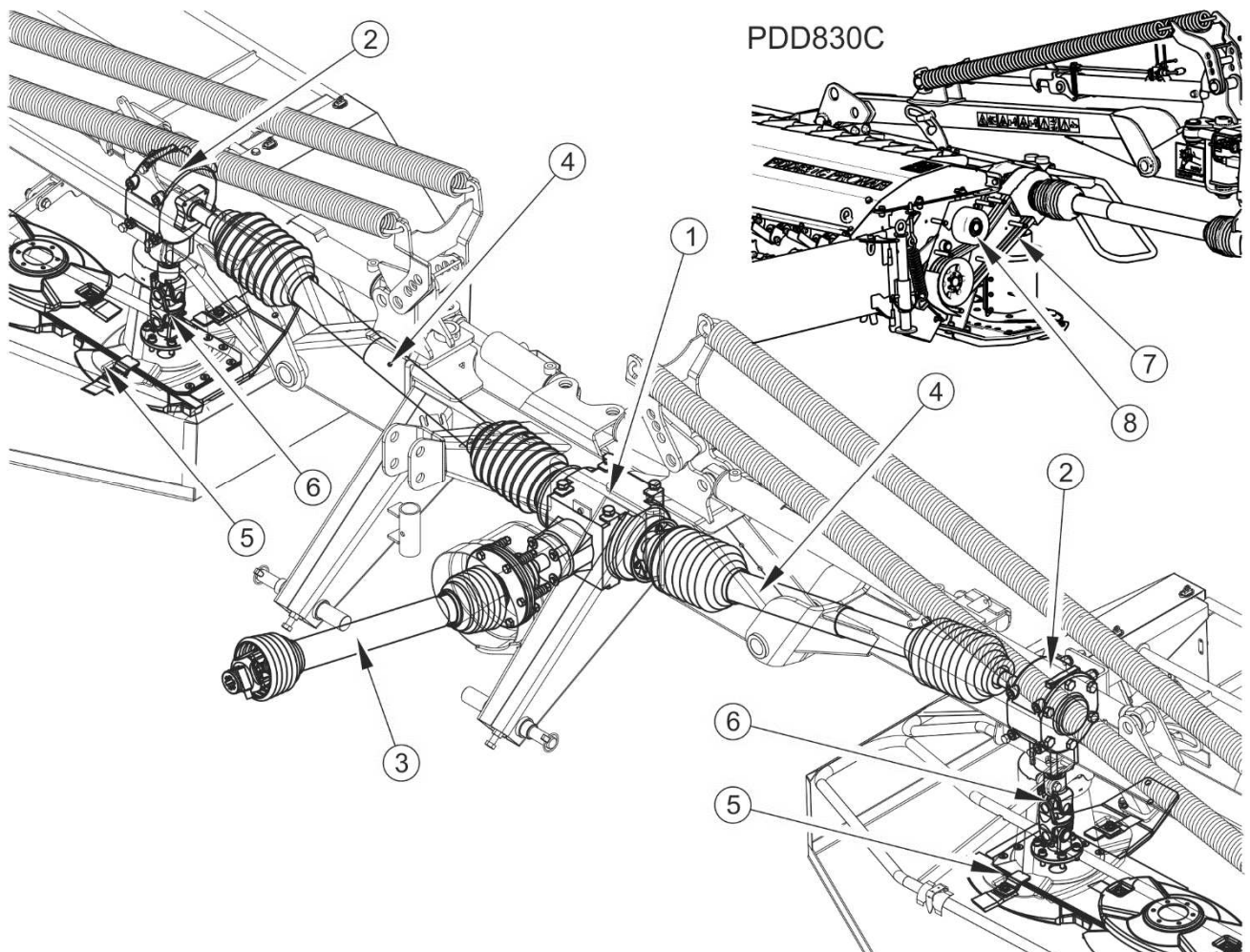

FIG. 3.3 Drive transmission

(1) mower central transmission, (2) cutter bar intersecting axis transmission, (3) PTO shaft with friction clutch for connection with tractor, (4) PTO shaft (5) cutter bar, (6) double articulated joint, (7) belt drive, (8) tensioner

3.5 CUTTING UNIT

The mower combination is equipped with two cutting assemblies with a working width of 3 m. The assembly is comprised of the cutter bar (1) on which are mounted 7 cutting discs (2). The cutter bar is mounted to the frame with the aid of feet (4). Two cutting blades (3) are mounted on each of the cutting discs, right or left depending on disc rotation direction.

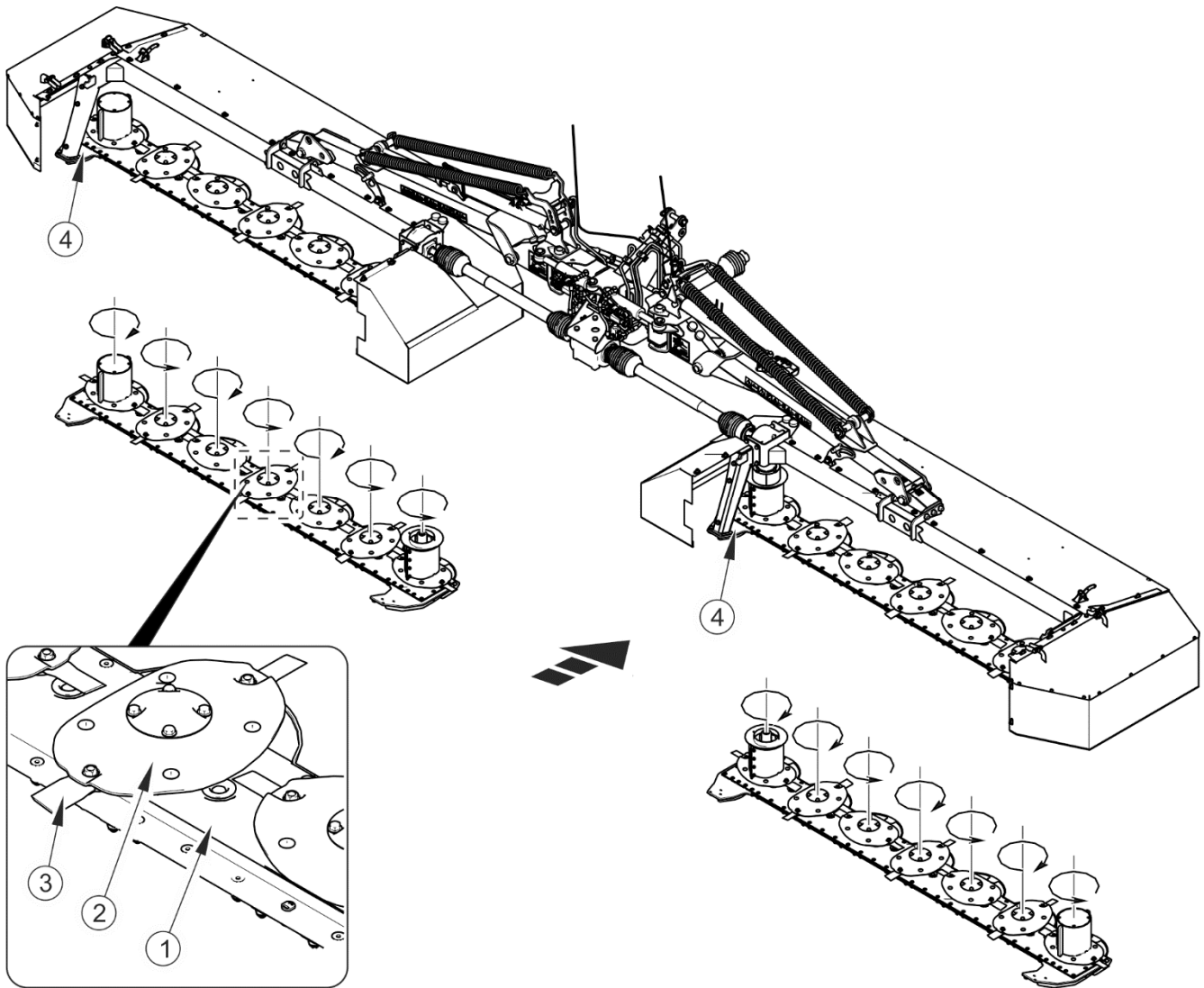

FIG. 3.4 Cutting unit

(1) cutterbar, (2) cutting disc, (3) blade, (4) foot

If disks rotate clockwise then right blades are mounted, if anticlockwise then left blades are mounted. On figure (3.4) arrows indicate rotation direction of specific cutting discs and cutting direction

3.6 HYDRAULIC SYSTEM

The hydraulic system is supplied from the tractor external hydraulics. The system is connected using three quickcouplers (3). Two of them connect the operating circuits of the right and left adjusting hydraulic cylinders (5). These cylinders serve as hydraulic protection, which protect the machine against damage resulting from collision with an obstacle. The third

quick coupler connects the operating circuit of the lifting arm cylinders (1), which raise and lower the mower cutting assemblies. The lifting arm cylinders (1) are connected with ball valves (2), which lock the position of the cylinders during transport.

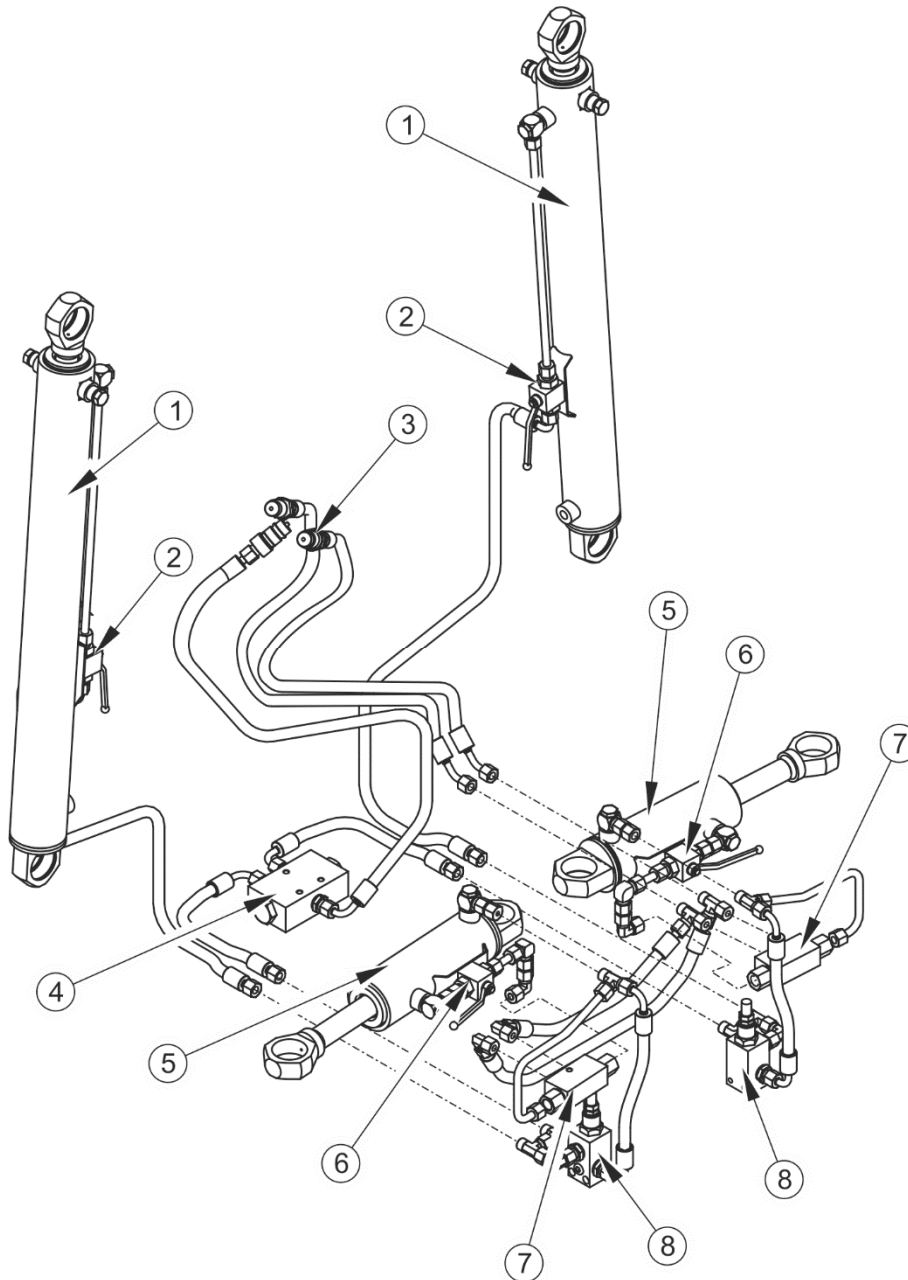

FIG. 3.5 Hydraulic system design

(1) load-bearing hydraulic cylinder, (2) load-bearing cylinder lock valve, (3) quick couplers - plug, (4) flow divider, (5) hydraulic adjusting-safety cylinder, (6) lifting cylinder lock valve, (7) hydraulic lock, (8) overflow transfer valve

3.7 CONDITIONER (PDD830C)

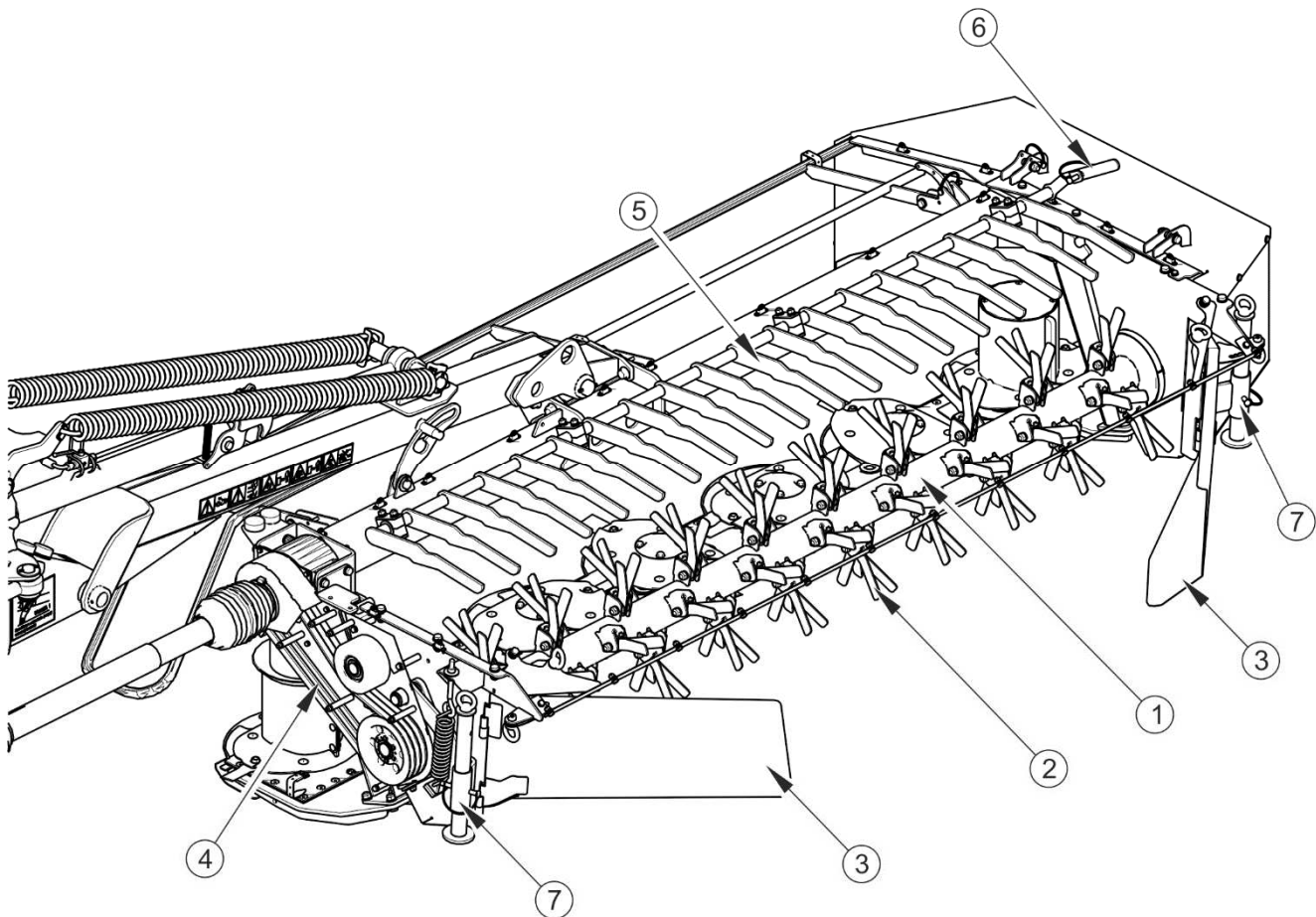

FIG. 3.6 Conditioner

(1) conditioner shaft; (2) conditioner flail blade; (3) swath guides; (4) belt drive; (5) damping fingers; (6) damping fingers adjustment lever; (7) conditioning assembly supports

PRONAR PDD830C mower conditioning assemblies consist of a shaft (1) on which conditioner spring tines (2) are fitted. Swath conditioner flail blades intercept material from the cutter bar and toss it over the conditioner shaft (1) to swath guides (3), which form a swath of a specific width depending on the setting.

The conditioning intensity can be adjusted using the lever (6), which sets the damping fingers (5) relative to the conditioner shaft so that the material is properly formed and conditioned. The entire conditioning assembly is driven by the intersecting axis gear through belt transmission (4), which in turn is driven by the cutterbar.

SECTION

4

CORRECT USE

4.1 PREPARING FOR WORK

The manufacturer guarantees that the mower is fully operational and has been checked according to quality control procedures and is ready for use. This does not release the user from an obligation to check the machine's condition after delivery and before first use. The machine is delivered to the user completely assembled.

Before connecting to tractor, machine operator must check the technical condition of the mower and prepare it for test start-up. In order to do this:

- the user must carefully read this Operator's Manual and observe all recommendations, understand the design and the principle of machine operation
- check the condition of protective paint coat,
- Inspect mower's individual components for mechanical damage resulting from incorrect transport (dents, piercing, bent or broken components),
- Check all the mower's lubrication points, lubricate the machine as needed according to recommendations provided in section 5,
- check if cutting blades, cutter bar, lifting arms and safety guards are correctly installed,
- check the compliance of PTO parameters, termination type, speed,
- make sure that the attached PTO shaft may be connected to the tractor (PTO shaft should be suitable for the tractor – see the Operator's Manual of PTO shaft),
- check technical condition of hitching system pins and locking cotter pins,
- check level of lubricating oil in angle transmissions and cutterbar.

If all the above actions are completed and if the technical condition of the mower is not a cause of concern then connect it to the tractor 4.3 "*HITCHING TO TRACTOR*". Start the tractor engine, check all systems and test the mower before beginning work. In order to inspect:

- ➡ connect the mower to tractor,
- ➡ connect PTO shaft to tractor and mower,

- ➔ set mower in working position,
- ➔ start tractor PTO slowly

ATTENTION



Before using the mower always check its technical condition. In particular check the technical condition of the cutting unit, drive system, and integrity of protective guards.

Never start the PTO when the mower is raised.

Discs and cutting blades work at high rotation speed and even the smallest damage may cause an increase in vibration, which after a certain time shall result in fractures and cracks.

Leave for several minutes working at low RPM, during which check:

- that there is no knocking or noise in the drive system arising from scraping or grinding of metal elements,
- whether there is excessive vibration in the cutting unit,
- if the discs on the cutterbar rotates smoothly without any faltering,
- synchronised rotation of cutting unit.

The mower's operation without load should be smooth. Shaking of cutting unit and whole machine is not acceptable, nor is changed noise and vibrations coming from loose nut and bolt connections. After stopping mower check fastening of cutting blades. Check that gear oil does not leak from reduction gear and cutterbar.

DANGER



Before using the mower, the user must carefully read this operator's manual.

Careless and improper use and operation of the mower, and non-compliance with the recommendations given in this operator's manual is dangerous to your health.

The mower must never be used by persons, who are not authorised to drive agricultural tractors, including children and people under the influence of alcohol or other drugs.

Non-compliance with the safety rules of this Operator's Manual can be dangerous to the health and life of the operator and others.

Before starting the mower, make sure that there are no bystanders in the danger zone.

If any faults are detected they must be identified and rectified. If a fault cannot be rectified or the repair could void the warranty, please contact retailer for additional clarifications.

4.2 CHECKING TECHNICAL CONDITION OF MOWER

When preparing the mower for normal use, check individual elements according to guidelines presented in table (4.1).

TAB. 1.1 TECHNICAL INSPECTION SCHEDULE

DESCRIPTION	SERVICE OPERATION	FREQUENCY OF INSPECTIONS
Operation of hydraulic system	Check the tightness of lines and proper operation of hydraulic cylinders.	Daily
Check that the cutting blades, mounting pins and discs are in good technical condition.	Visually inspect and if necessary replace damaged parts.	
Check oil level in intersecting axis gears	For details please refer to section "DRIVE SYSTEM OPERATION"	
Check oil level in cutterbar	For details please refer to section "CUTTERBAR OPERATION"	
Check tightness of securing nuts and bolts	Torque values should be according to table (5.5)	Every three months
Lubrication	Lubricate elements according to guidelines presented in section "LUBRICATION".	According to table (5.3)



ATTENTION

Do NOT use unreliable mower.

Prior to connecting hydraulic system lines the user must carefully read the tractor operator's manual and observe all recommendations of the Manufacturer.

4.3 HITCHING TO TRACTOR

The mower combination may only be mounted on a tractor fulfilling the requirements contained in table 1.1 "AGRICULTURAL TRACTOR'S REQUIREMENTS".



ATTENTION

Before using the mower, the user must carefully read the tractor operator's manual.

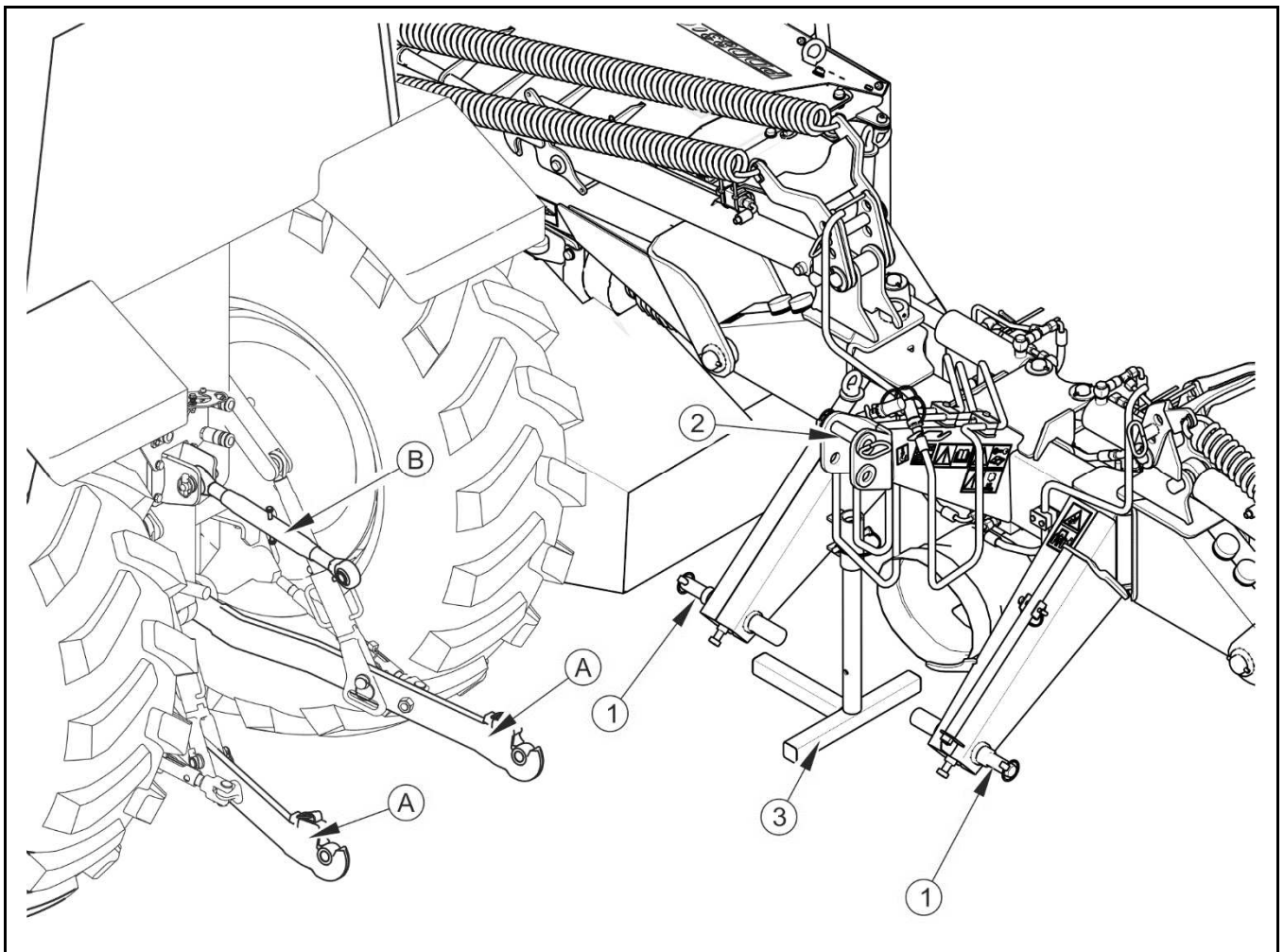

FIG. 4.1 Hitching to tractor

(A) three point linkage arms, (B) central connector, (1) lower pin, (2) central connector mounting pin, (3) support leg

In order to attach the mower to tractor, proceed as follows:

- ➔ Reversing the tractor bring the lower three point linkage connection points (A) of the tractor close to pins (1) of the mower.
- ➔ Set the link arms at the appropriate height.
- ➔ Turn off tractor engine and prevent it from moving.
- ➔ Connect lower pins (1) with linkage arms (A) and lock with the aid of cotter pins,
- ➔ Connect central connector (B) of tractor with pin (2) mower and lock with cotter pin.

Set both tractor lower linkage arms at the same height.



DANGER

**To hitch the machine to tractor use only genuine pins and safeguards.
When hitching, there must be nobody between the machine and the tractor.**

Lower pins (1) of the mower linkage enable spacing adjustment (*FIGURE 4.2*) in range 795 - 970 mm. To change spacing of linkage pins:

- ➔ Loosen counter nut (3),
- ➔ Unscrew setting bolt (2),
- ➔ Move pin (1) to the right or the left to obtain the required spacing,
- ➔ Block pin position with setting bolt (2) and counter nut (3)

The method of adjustment of right and left pins is identical.

As standard combination mower is equipped with pins for linking with category II linkage according to ISO 730. To adapt the mower for category III linkage, the optional pins should be used.

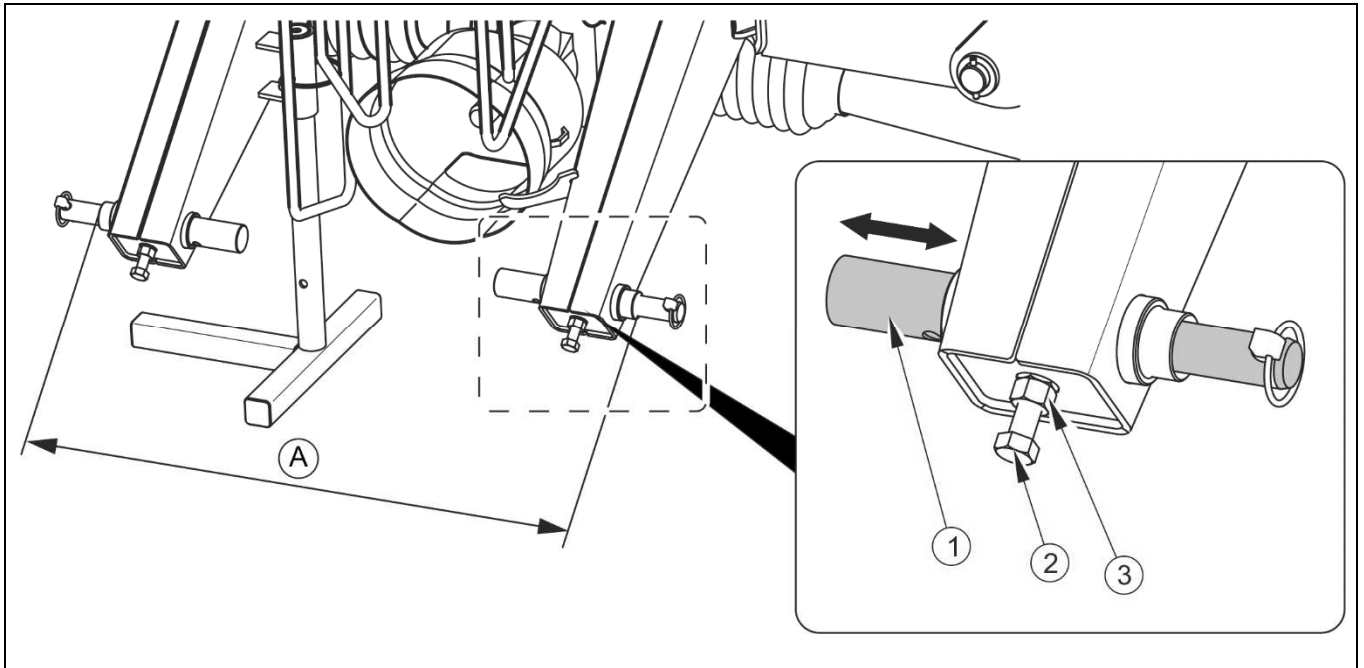

FIG. 4.2 Adjustment of mower lower mounting pins

(A) pin spacing in range 795 ÷ 970mm, (1) linkage lower pins, (2) retaining bolt, (3) counter nut

DANGER



When hitching, there must be nobody between the mower and the tractor. when hitching the mower, tractor's driver must exercise caution and make sure that nobody is present in the hazard zone.

Prior to connecting hydraulic system lines the user must carefully read the tractor operator's manual and observe all recommendations of the Manufacturer.

Line connections of the raising cylinders of the cutting unit lifting frames should be connected to the hydraulic circuit equipped with so-called "floating section". Line connections of tipping cylinders of the lifting frames should be connected to double acting hydraulic circuit.

DANGER



When connecting the hydraulic lines to the tractor, make sure that the tractor hydraulic system is not under pressure.

4.4 TRANSPORTING THE MACHINE

For transport to place of work and back, set mower in transport position (*FIGURE 4.3*) and raise tractor three point linkage so that the lower pins are at height of not less than 500 mm above the ground. Disconnect PTO shaft from tractor's PTO and place on support. When driving on public or private roads, respect the road traffic regulations, exercise caution and prudence.

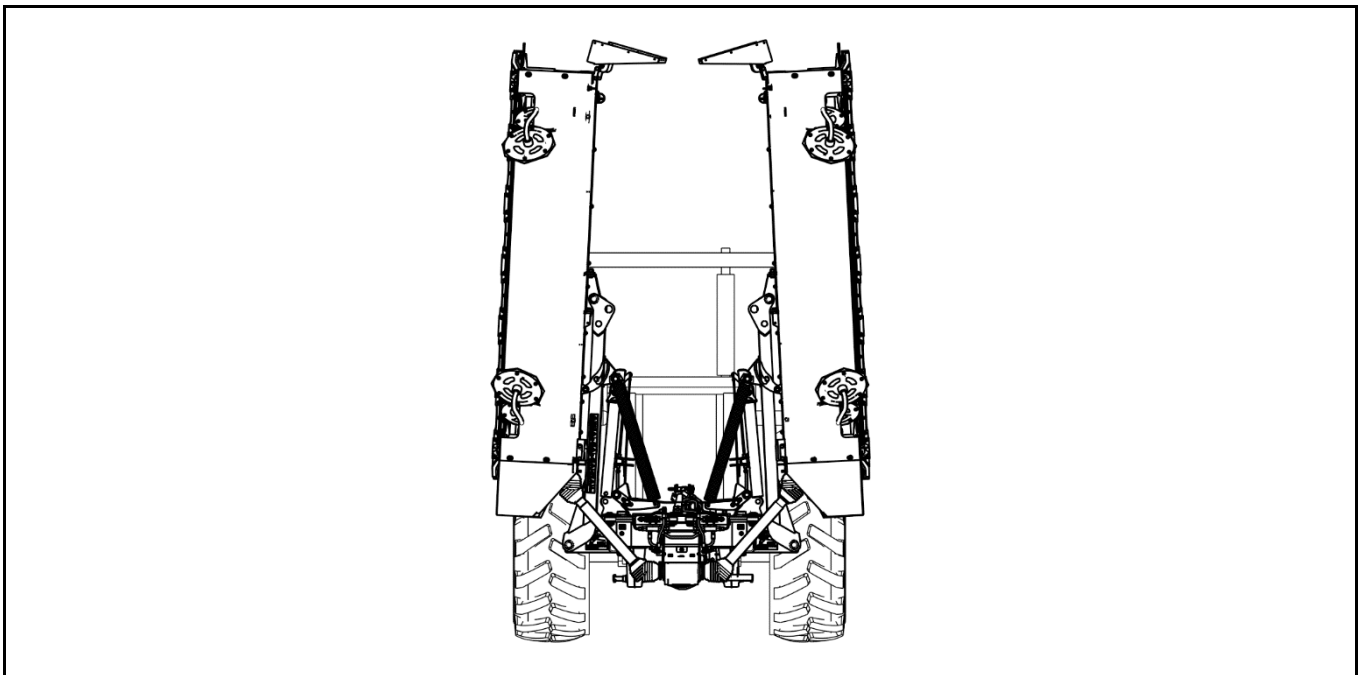

FIG. 4.3 Transport position

To prepare mower for transport (travel on roads) perform the following actions on the tractor:

- ➔ raise the mower lateral guards – figure (4.5),
- ➔ set hydraulic cylinder locks (1) and (2) in open position "I" - figure (4.4),
- ➔ using the appropriate tractor external hydraulic levers raise the lifting frame together with cutting unit until blocked by hydraulic cylinder lock (2).
- ➔ Secure lifting frame against falling by closing cut-off valve (2),
- ➔ lift mower on tractor lower linkage arms using three point linkage.

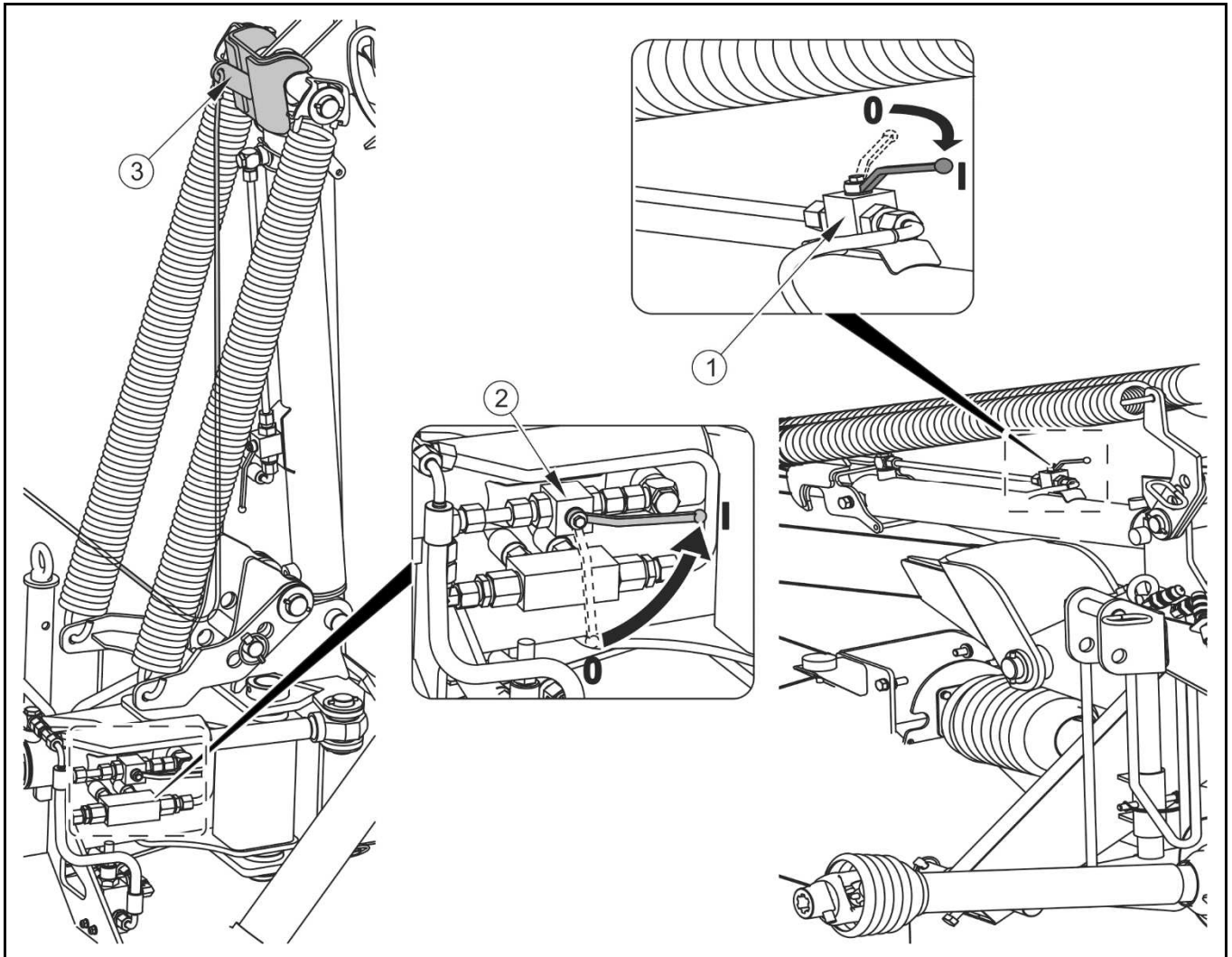

FIG. 4.4 **Setting transport position**

(1) *lifting arm hydraulic cylinder cut-off valve*, (2) *tipping cylinder cut-off valve*, (3) *cylinder lock*

To reduce height of mower in transport position open lateral guards (1) and lock in open position, *FIGURE (4.5)*. To open guards:

- ➔ release rotation catches (3), on both sides of mower.
 - ⇒ They are for connecting elastic guards,
- ➔ release and take out securing pin (2),
- ➔ raise lateral guards (1),
- ➔ secure guards open position (2) placing pin in appropriate bracket opening.

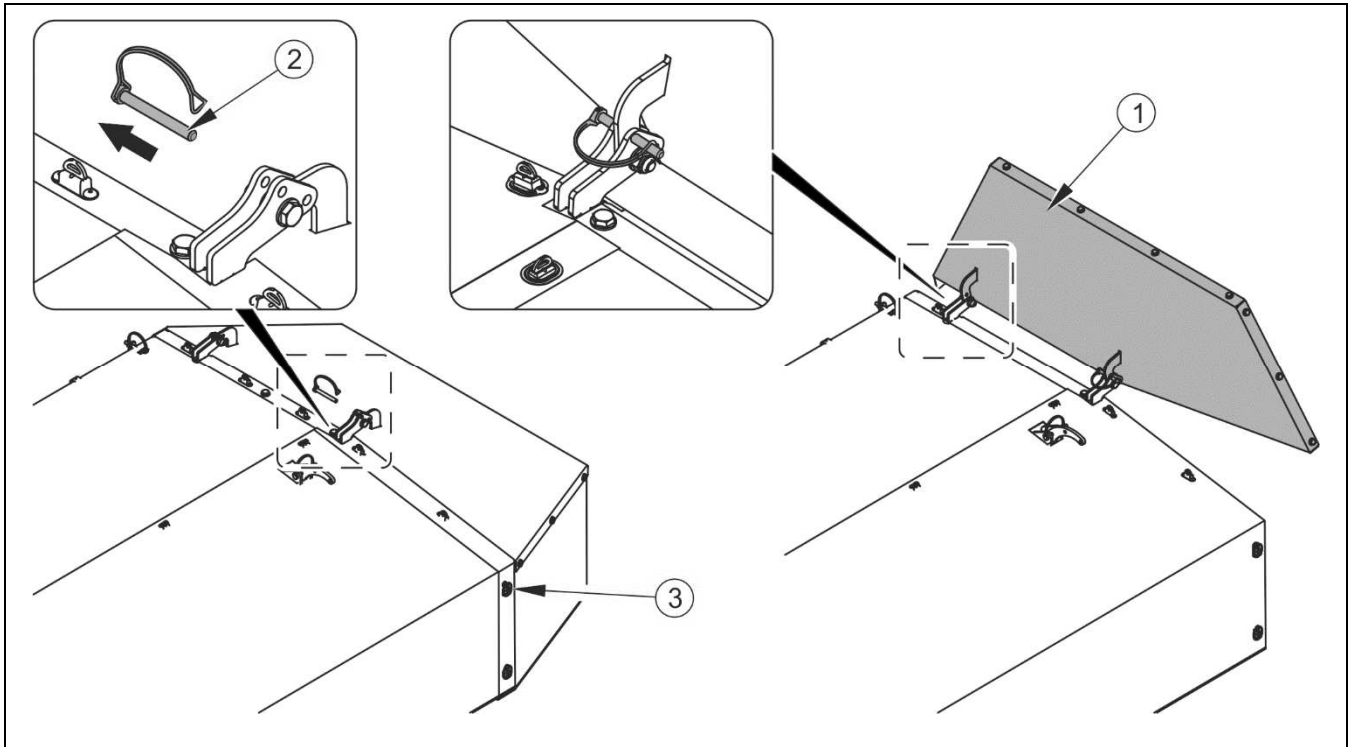

FIG. 4.5 Raising guards for transport

(1) side shield, (2) securing pin, (3) rotation catch

Listed below are the key guidelines for driving the tractor and mower combination.

- Transport on public roads and outside fields must always take place with raised machine.
- Before moving off make sure that there are no bystanders, especially children, near the mower or the tractor. Take care that the driver has sufficient visibility.
- Make sure that the mower is properly attached to the tractor, and that the PTO shaft is correctly secured.
- Permissible design speed and maximum speed allowed by road traffic law must not be exceeded. Travel speed should be adapted to the current road conditions.



ATTENTION

Do NOT travel with machine which has an unreliable brake, lighting or signalling system.

- Speed must be sufficiently reduced before making a turn or driving on an uneven road or a slope.

- Monitor mower's behaviour when travelling on an uneven terrain, and adjust driving speed to road conditions, slow down early enough when turning.

**DANGER**

Do NOT transport mower mounted on tractor with open hydraulic valves. Valves must always be set in position "0" - closed.

4.5 SETTING AND MOWING

4.5.1 SETTING WORKING POSITION

To work with the combination mower first set it appropriately. The machine cutting unit is capable of moving up and down in relation to the linkage frame. Such a solution enables the cutting unit to respond to unevenness of the mown field, when the linkage frame moves according to the movements of the tractor. For the mower to work optimally set it to the base position recommended by the Manufacturer. In order to set it:

- ➔ valves (1) and (2) tipping cylinders and lifting cylinders raising lifting arms should be set in open position "I"- figure (4.6),

**ATTENTION**

Before lowering lifting arms check that the space is clear and that there is nobody nearby.

- ➔ release locks (4) of lifting arm interlock by pulling cables (3) and by operating tractor hydraulic circuit, lower lifting arms with cutting unit so that the cutterbar is supported freely on the ground, set hydraulic circuit in float position,
- ➔ set tractor three point linkage lower links at height of A=400mm so that the pin is more or less in mid lock range (3) - figure (4.7).

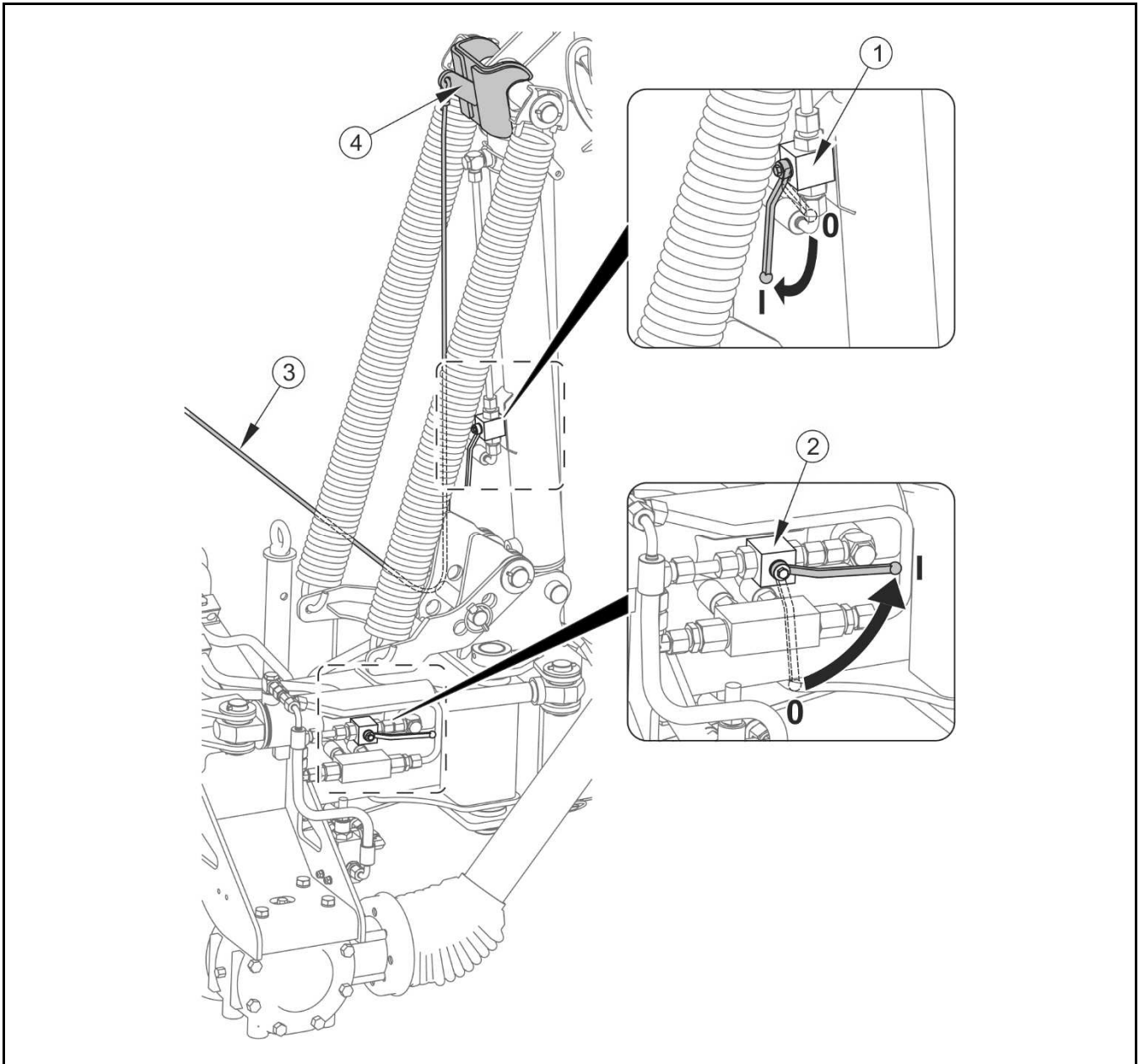

FIG. 4.6 **Setting mower in working position**

(1) lifting arm hydraulic cylinder interlock valve, (2) tipping cylinder interlock valve, (3) cylinder lock cable, (4) cylinder lock

4.5.2 CUTTING HEIGHT ADJUSTMENT

After lowering mower to the ground set cutting height. Changes of setting are made by shortening or lengthening the central connector (2) so that the angle (B) of inclination of cutterbar (1) is from 4° to 5°. Lengthening connector increases the cutting height and shortening reduces the cutting height.

**NOTE**

Optimum cutter bar inclination angle to the front is from 4° to 5° . Inclination to the rear causes faster wearing of cutterbar slide surfaces.

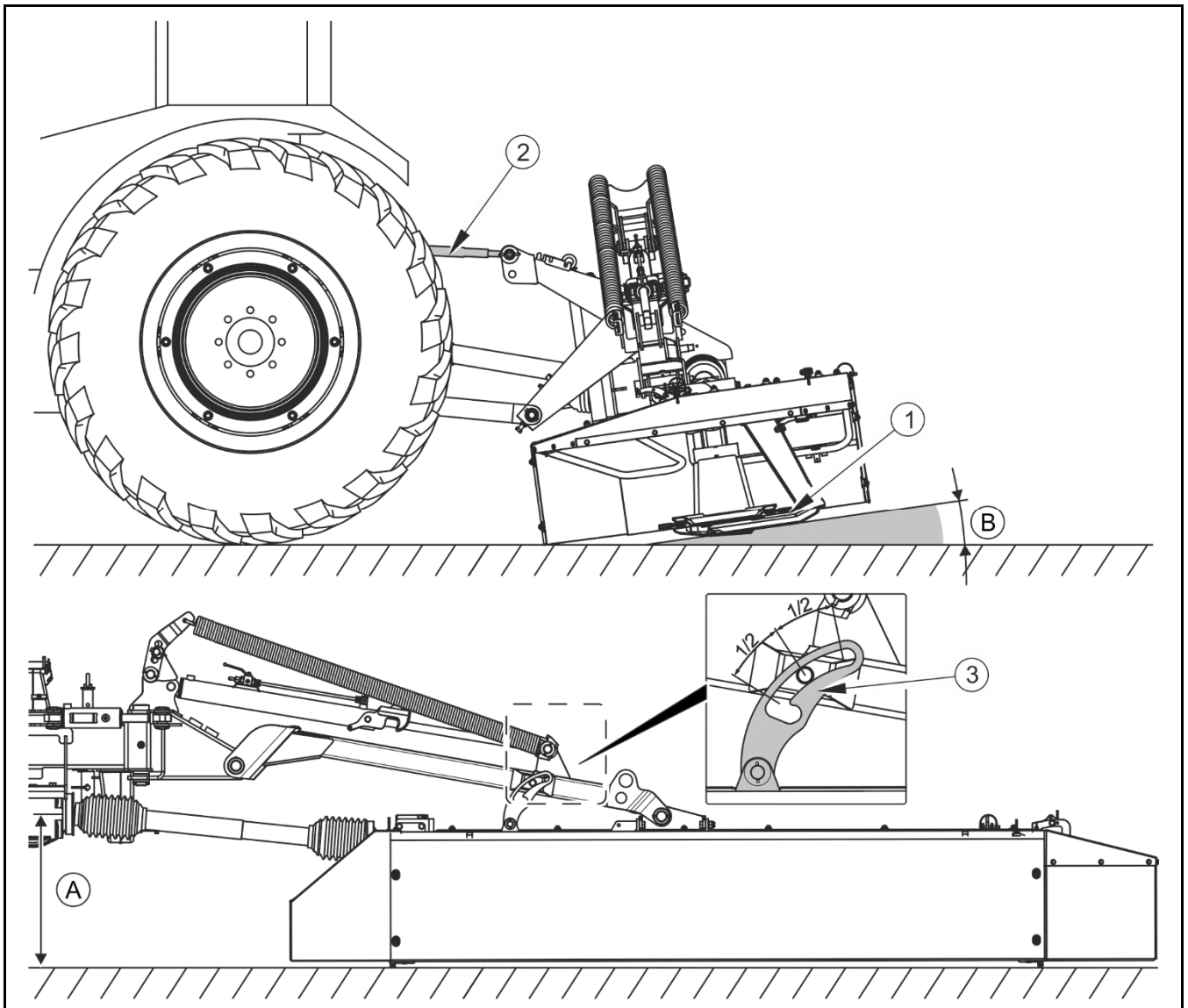

FIG. 4.7 **Setting cutting height**

(A) distance of lower link arms from ground - 400mm, (B) cutter bar inclination angle - 4° to 5° ,
 (1) cutter bar, (2) central connector, (3) lock

4.5.3 ADJUSTMENT OF CUTTERBAR PRESSURE

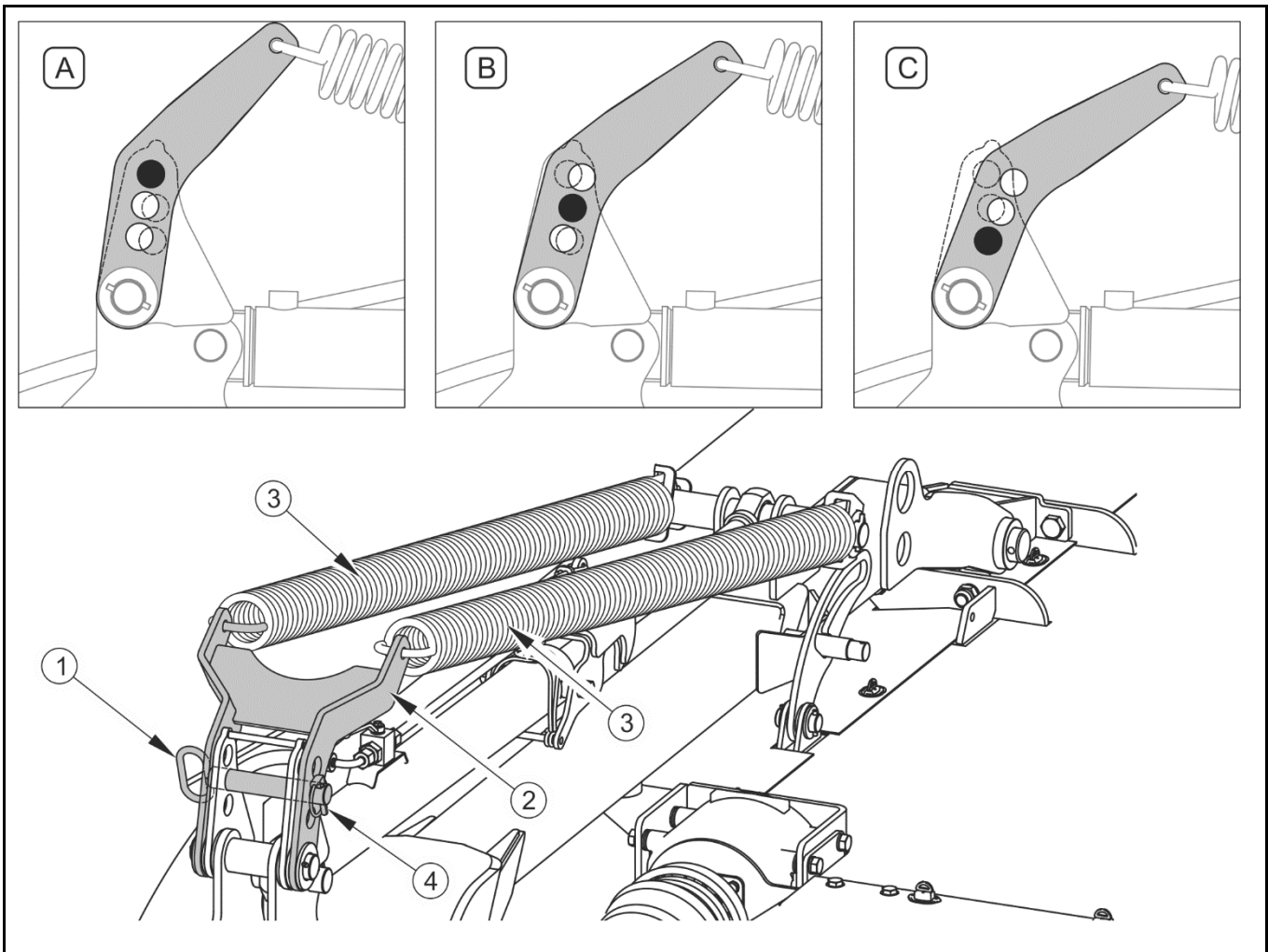

FIG. 4.8 Adjustment of cutter bar pressure

(A) pressure setting for 70kg, (B) pressure setting for 80kg, (3) pressure setting for 90kg, (1) locking pin, (2) spring bracket, (3) stay springs, (4) locking pin cotter pin.

In order to protect the stubble during cutting and reduce partial wear on slide skates of the cutting unit and also to ensure good ground surface tracking it is necessary to adjust the pressure of the cutterbar on the surface appropriately. The stay springs (3) are for this purpose. The pressure must be suitable to the ground conditions, the means of movement, type of surface and type of forage mown. Depending on the setting the pressure value on the surface may be 70, 80 or 90kg.

The loading is adjusted by changing the tension of both springs (3) on each arm separately. In order to make adjustment:

- ➔ raise the lifting arms of the cutting unit to reduce spring loading,

- ➔ remove securing cotter pin (4) and take out pin (1),
- ➔ set bracket accordingly (2), in order to enable insertion of pin (1) in appropriate opening (A, B, or C),
- ➔ secure the pin in the chosen position with cotter pin (4).



ATTENTION

Machine loading is set in a factory so that pressure on the soil is suited to work in normal conditions.

4.5.4 CONNECTING DRIVE SHAFT

Before proceeding to connect the mower it is essential read the PTO shaft operator's manual and observe the instructions it contains. In particular, check the condition and integrity of the guards and securing chains.



DANGER

Before connecting the shaft, turn off the tractor engine and remove the key from the ignition. Ensure that unauthorised persons do not have access to the tractor.

The use of PTO shaft and its technical condition must be in accord with the Operator's Manual of PTO shaft.



ATTENTION

Before first use, adjust the length of PTO shaft according to Operator's Manual of PTO shaft recommendations.



TIP

Adjustment of the PTO shaft applies only to a specific type of tractor. If the machine is connected to a different type of tractor, the adjustment procedure for this type of tractor should be possibly carried out.

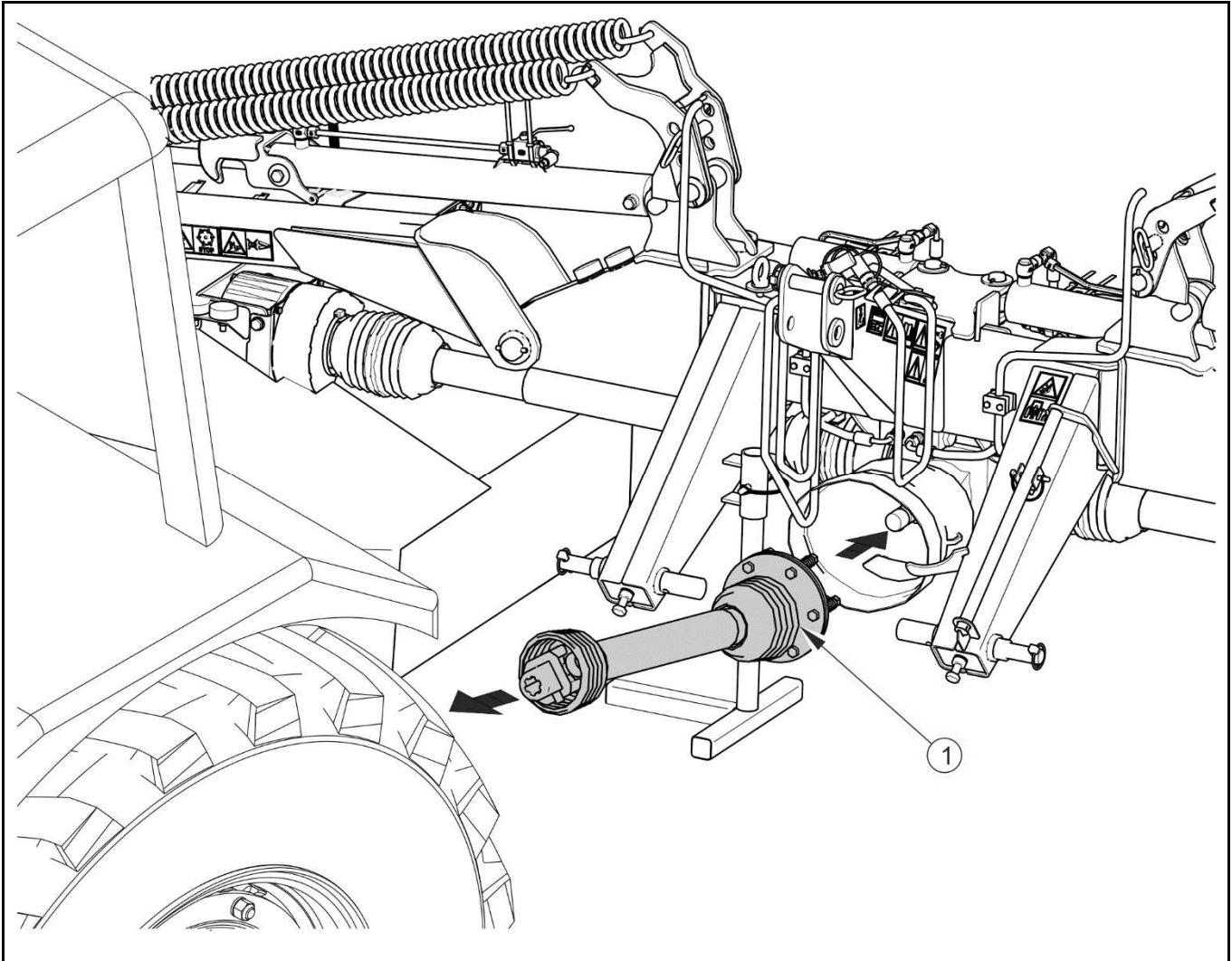

FIG. 4.9 **Connecting of PTO shaft**

(1)- PTO shaft backstop overload release clutch

The PTO shaft, which connects PTO of the tractor with the mower's central transmission and is equipped with an overload and backstop clutch. Connecting the shaft it is necessary to connect the end of the shaft fitted with the clutch to the mower side - figure (4.9). The value of the transferred torque on the shaft is set by the Manufacturer and may not be changed independently. Change of overload protection clutch setting may invalidate the warranty

PTO shaft collecting both intersecting axis gears does not require installation or dismantling.

4.5.5 SETTING THE SWATH WIDTH IN PDD830 MOWER

Before proceeding to mowing, set the swath width so that the cut grass is not crushed by the tractor wheels.

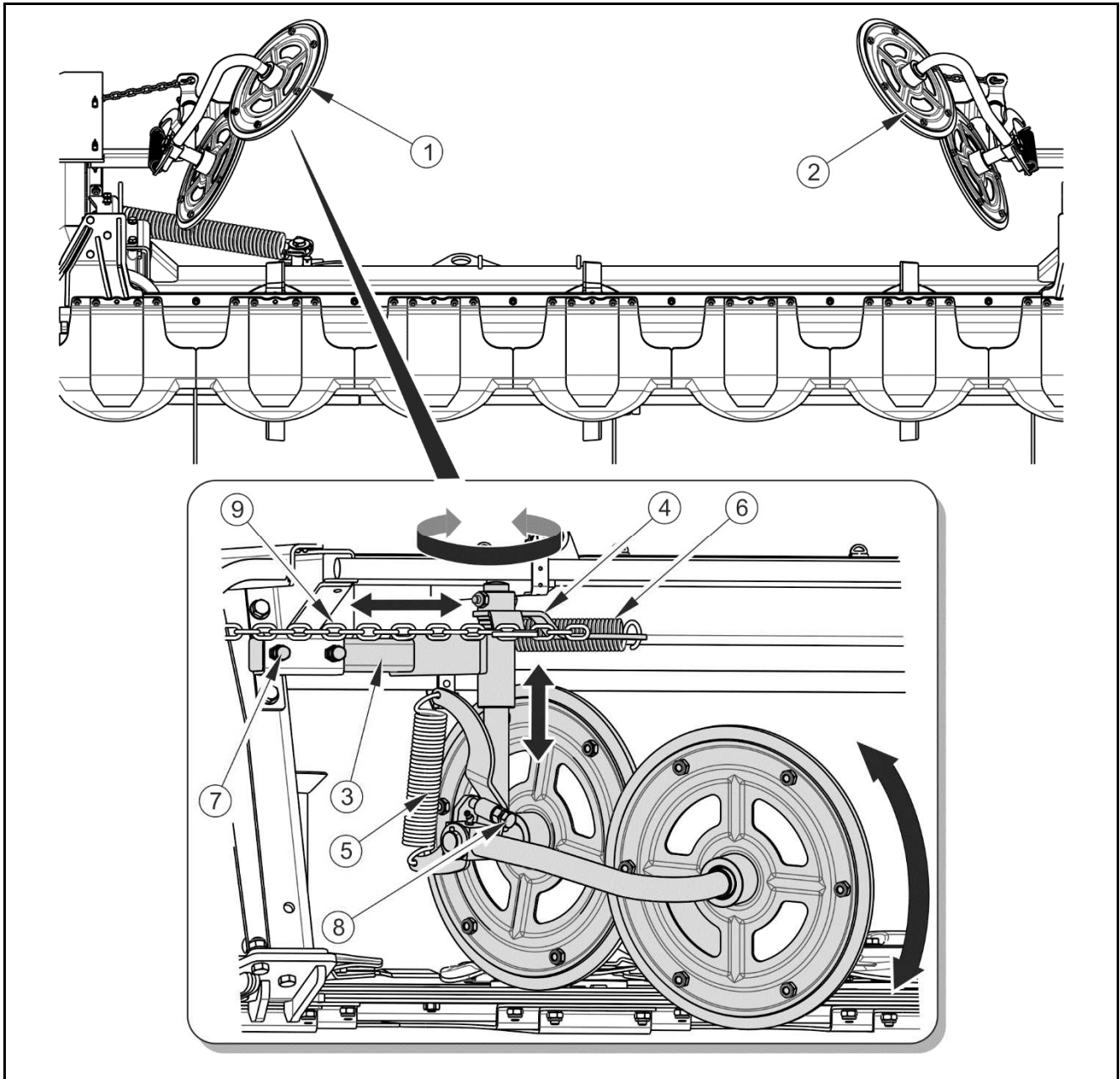

FIG. 4.10 Settings swath width

(1) swath guide left (2) swath guide right, (3) swath guide arm, (4) head, (5) vertical plane swath guide assembly shock absorbing spring, (6) horizontal plane swath guide assembly shock absorbing spring (7) arm adjustment bolt (8) vertical plane spring tension adjustment bolt, (9) limiting chain

DANGER

When adjusting swath guides exercise caution as there is a risk of crushing fingers with spring tensioned mechanisms.

After completing the adjustments make sure all bolt connections are tight and the range of swath guides motion is correct. The mower may only be started when all guards are in place.

You may adjust the swath width smoothly within 1 200÷2 000 mm by adjusting the two swath guides as appropriate.

In order to adjust swath guide horizontally:

- ➔ loosen counter nuts and adjustment bolts (7),
- ➔ move arm (3) as required, tighten bolts (7) and secure with counter nuts,

Besides the adjustment of the guide unit operating width you may also adjust the dampening scope of the spring (6) in the horizontal plane, which also affects the swath width. To this end, adjust the length of the limiting chain (9) as appropriate by attaching it in the head (4) fastening hole at the right length (4). When fitted, secure the limiting chain against slipping out of the head.

Follow the same procedure to adjust the second swath guide for this cutterbar, and swath guides for the other cutterbar. In the event of a blockage, set the widest swath.

4.5.6 SETTING THE SWATH WIDTH IN PDD830C MOWER

Two swath guides installed on the conditioner unit support frame are used to adjust the swath width.

You may adjust the swath width smoothly within 1 500 ÷ 2 300 mm by adjusting the two swath guides (1) as appropriate. To adjust swath guide position:

- ➔ loosen the adjusting screw (3) in the kidney slot of the bracket (4) at the swath guide (1),
- ➔ rotate swath guide (1) setting the appropriate swath width, and tighten the adjusting bolt (3) in the kidney slot,

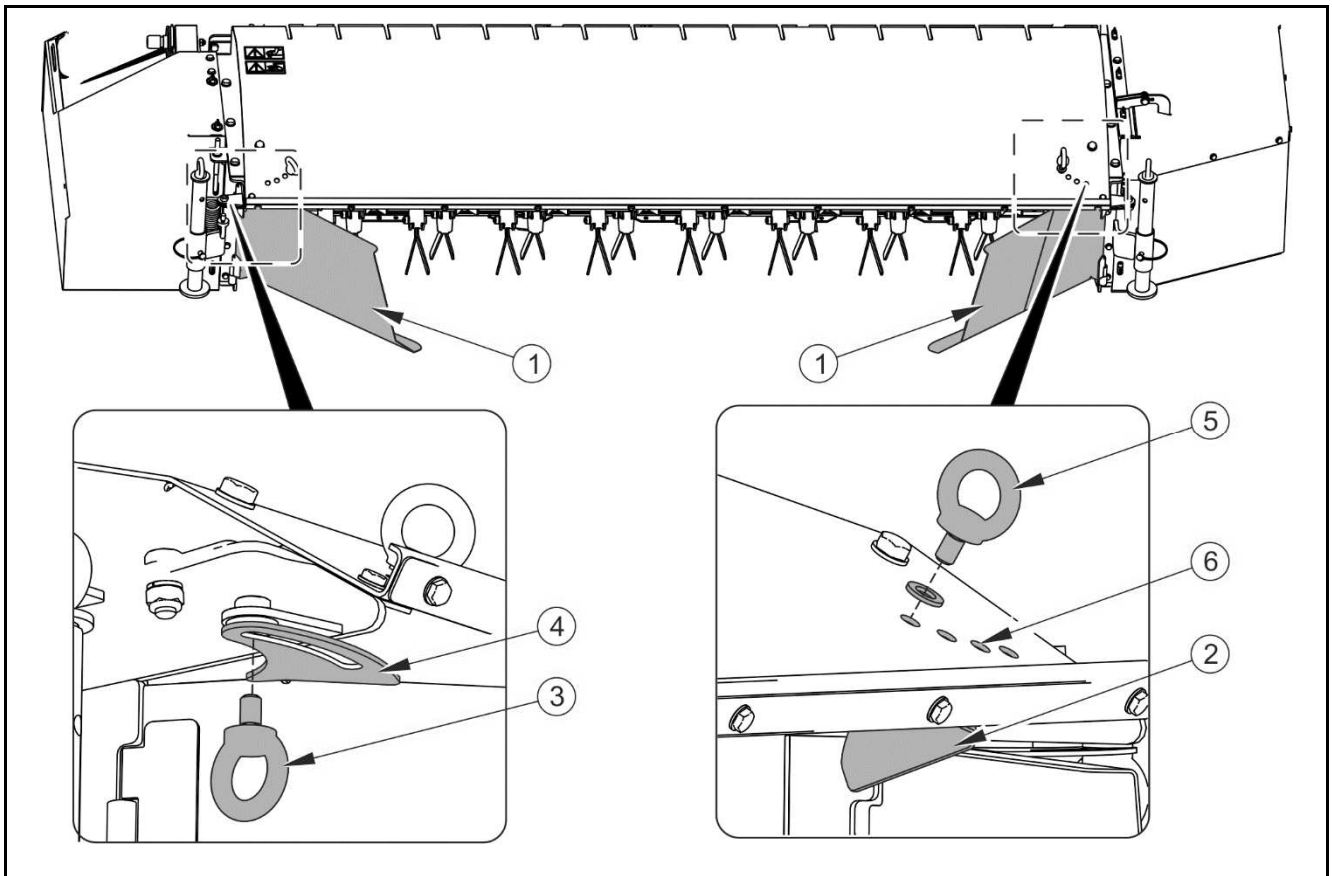

FIG. 4.11 Settings PDD830C swath width

(1) swath guide, (2) swath blade, (3) swath guide adjustment bolt, (4) swath guide bracket with a kidney slot; (5) swath blade adjustment bolt, (6) swath blade adjustment openings.

Then adjust the setting of swath blade (2) appropriately to the swath guide (1) so that the mown materials is directed to swath guide. In order to do this:

- ➔ unscrew the adjusting screw (5),
- ➔ set swath blade (2) as required so that its opening is in line with the opening (6) in conditioner body
- ➔ tighten the adjusting screw (5) in the selected hole (6).

Proceed the same way with the opposite swath guide and swath blade. Perform all adjustments for the other cutterbar.

4.5.7 SET THE CONDITIONING INTENSITY IN THE PDD830C MOWER

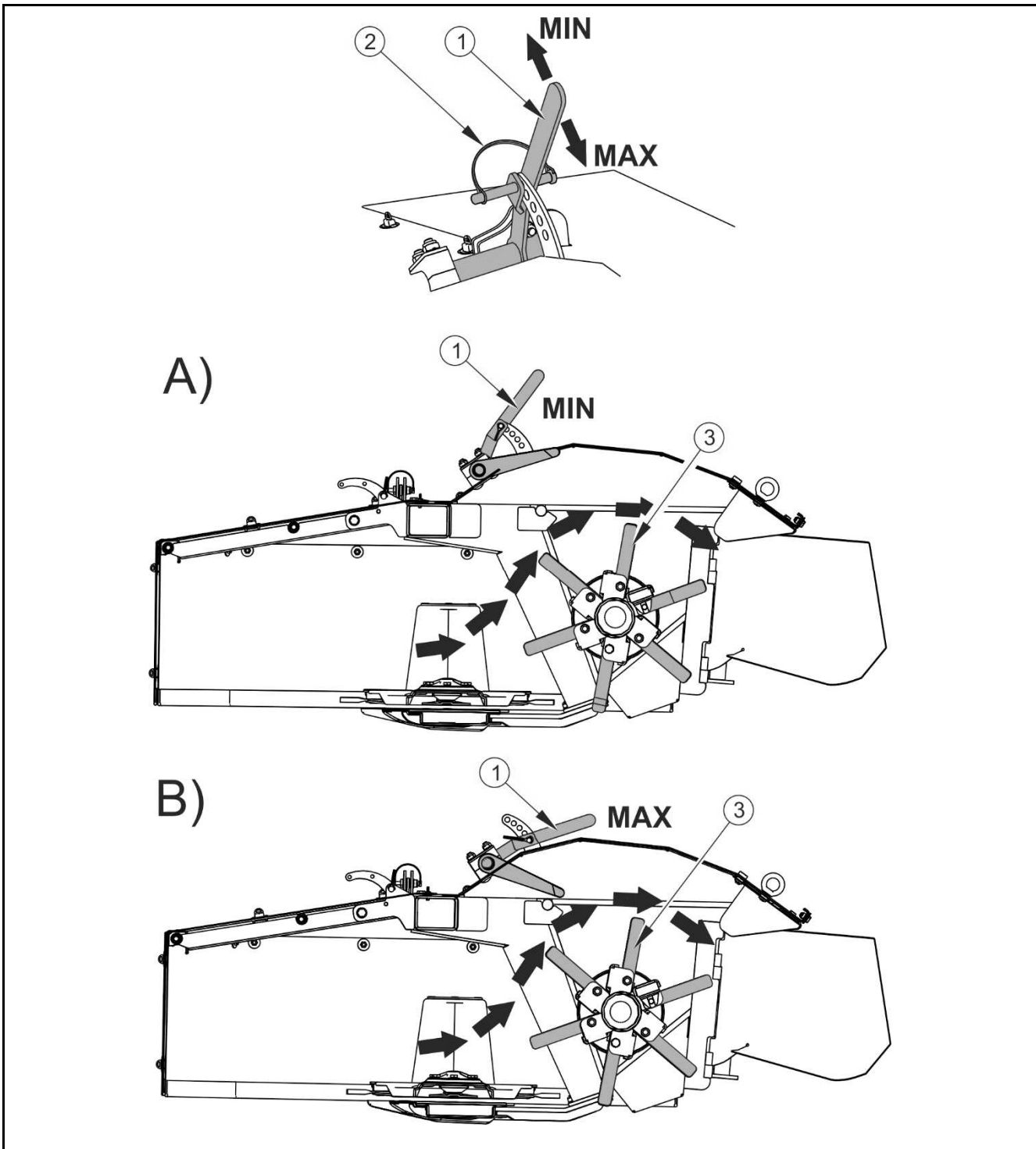

FIG. 4.12 Settings PDD830C swath width

A- minimum swath conditioning intensity setting; B- maximum swath conditioning intensity setting; (1) - swath conditioner adjustment lever, (2) - cotter pin, (3) - swath conditioner flail blades

Depending on the type and density of the mown material, you can set the intensity of swath conditioning - figure (4.12). This is done by the lever (1) on the support frame of the conditioning assembly connected to the damping fingers. The damping finger must be adjusted so that the mown material does not collect between the cutterbar and conditioning shaft.

To adjust swath conditioning intensity:

- ➔ release and remove the securing cotter pin (2),
- ➔ move the adjustment lever (1) down to achieve a greater mown material conditioning intensity (MAX) or up to reduce the conditioning intensity;
- ➔ adjust the lever so that the hole in the lever is in line with a hole in the bracket;
- ➔ insert cotter pin (2) in the hole and secure it.

4.5.8 MOWING

After setting mower in working position, setting cutter bar and stay springs inclination angle, observe the following procedure:

- ➔ at low engine RPM connect PTO drive,
- ➔ gradually increase RPM until reaching 1000 rpm for PTO,
- ➔ engage appropriate tractor gear and drive into standing crop.

During mowing the lever controlling the cutting unit's hydraulic lifting circuit should be set in "floating" position, however the lever controlling arm inclination (hydraulic safety device) should be set in neutral position. cutting speed should be adjusted to the existing conditions that is the density of the crop, and the type of ground surface, on which one is cutting. The driver must always have the tractor under control and avoid unevenness and foreign bodies in front of the tractor and machine. On hilly terrain the working speed should be reduced and the driver must pay attention to movements of the machine in relation to the ground surface.

ATTENTION



If the machine is in the working position and cuts, the lifting arm cylinders must always be set in floating position so that the cutting unit may move freely tracking the ground contours optimally.

Never start the PTO when the mower is raised.

On uneven ground there is a risk of the machine colliding with mounds of soil or foreign bodies and the driver must minimise the risk of damaging the machine.

During crossing over swaths with the mower and during turning the mower cutting unit must first be raised with hydraulic cylinders and the number of revs and ground speed must be reduced. Travel speed must be reduced if:

- mown ground is uneven,
- crop is laid, or very tall and dense,
- there is a great risk of running into foreign bodies e.g. stones, branches and heaps of soil.

If during cutting the overload release clutch of the drive shaft is activated, disconnect PTO drive in tractor and check what caused the overload. The overload release clutch may be activated because of clogging or too low rotation speed of cutting unit.

In order to remove the cause of machine clogging you need to lower the cutting unit, turn off the PTO, turn off the engine, remove the key from the ignition and take special care.

DANGER



Along banks, ditches and furrows always be especially careful and reduce speed because of the possibility encountering foreign bodies and because of soil differences on the edges of banks and furrows. Not reducing speed may cause the soil to slip and the tractor and machine to overturn.

HIGH NOISE LEVEL WARNING



Depending on the working conditions, the tractor (implement carrier) with the machine may generate noise exceeding the level of 85dB at the driver position. In such conditions the driver should apply individual protection (protective ear guards).

In order to reduce the level of noise during work the tractor cab window and door should be closed.

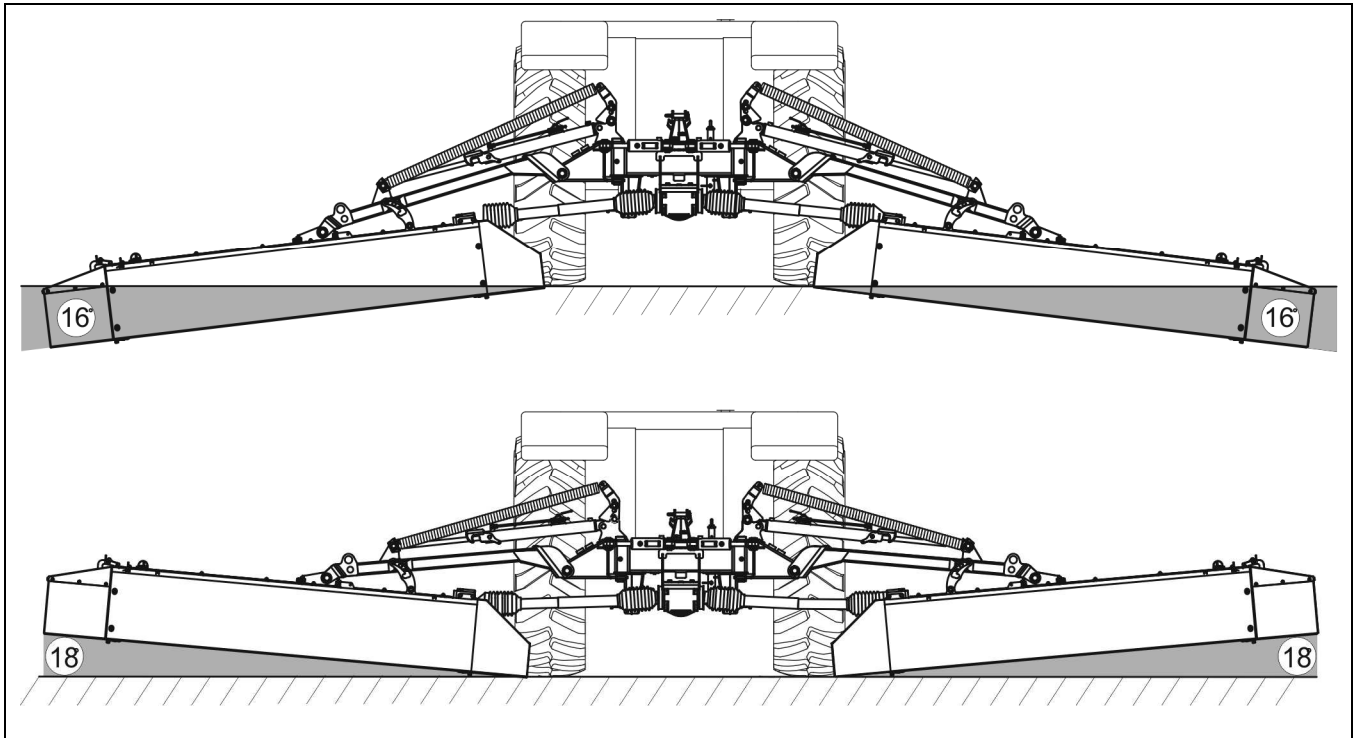

FIG. 4.13 Range of inclination of cutting unit

The mower is equipped with a hydraulic safety device, which protects the machine against damage resulting from collision with obstacles. When colliding with an obstacle the lifting arm rises and swings backwards. After passing the obstacle the cutting unit returns to the horizontal position and swings forward using the lifting arm inclination hydraulic cylinder. In order to enable action of the hydraulic safety device, both cylinder valves on each lifting arm should be set in open position.

ATTENTION



The machine design does not allow reversing with the machine in working position.

During cutting always maintain constant RPM speed of 1000 rpm for optimum cutting performance. If RPM speed falls the drive loading increases significantly and it may occur at the friction clutch would be activated to protect the system. In such a situation always disconnect the drive and check the cause of the overloading.

Give special attention to sudden movements and impacts in the cutting unit. After a strong impact was an obstacle always check the machine in case of possible damage. Damaged elements must be replaced.

4.6 DISCONNECTING FROM TRACTOR

Disconnect the mower and store horizontally on paved ground. Must be supported on the support leg and cutterbar, while PDD830C mowers on the conditioner supports.

DANGER



Before disconnecting tractor from mower check that the machine is protected against falling over.

Reduce pressure prior to disconnecting the hydraulic system.

During disconnection there must be nobody between the mower and the tractor.

Before lowering or raising the cutting unit ensure that nobody is near the machine and that nobody is doing any work that may be affected.

In order to disconnect the mower from the tractor proceed as follows:

- ➔ Release mower support foot and insert locking pin to secure it,
- ➔ lower mower using three point linkage to rest position,
- ➔ set lifting cylinder valves (1) in open position I- figure (4.6),
- ➔ release lock (4) of lifting arm interlock by pulling cable (3) and by operating tractor hydraulic circuit, lower lifting arms with cutting unit so that the cutterbar is supported freely on the ground, set hydraulic circuit in float position — figure (4.6)
- ➔ turn off tractor engine and remove key from ignition,
- ➔ reduce residual pressure in the hydraulic system by movement of appropriate lever controlling hydraulic circuit,
- ➔ disconnect hydraulic line connectors from tractor and secure with stoppers and place in special brackets on mower frame,
- ➔ disconnect PTO shaft from tractor's PTO drive and place on special bracket on mower frame,
- ➔ disconnect top link of three point linkage,
- ➔ disconnect mower pins from lower tractor linkage arms and drive away.

SECTION

4

CORRECT USE

4.1 PREPARING FOR WORK

The manufacturer guarantees that the mower is fully operational and has been checked according to quality control procedures and is ready for use. This does not release the user from an obligation to check the machine's condition after delivery and before first use. The machine is delivered to the user completely assembled.

Before connecting to tractor, machine operator must check the technical condition of the mower and prepare it for test start-up. In order to do this:

- the user must carefully read this Operator's Manual and observe all recommendations, understand the design and the principle of machine operation
- check the condition of protective paint coat,
- Inspect mower's individual components for mechanical damage resulting from incorrect transport (dents, piercing, bent or broken components),
- Check all the mower's lubrication points, lubricate the machine as needed according to recommendations provided in section 5,
- check if cutting blades, cutter bar, lifting arms and safety guards are correctly installed,
- check the compliance of PTO parameters, termination type, speed,
- make sure that the attached PTO shaft may be connected to the tractor (PTO shaft should be suitable for the tractor – see the Operator's Manual of PTO shaft),
- check technical condition of hitching system pins and locking cotter pins,
- check level of lubricating oil in angle transmissions and cutterbar.

If all the above actions are completed and if the technical condition of the mower is not a cause of concern then connect it to the tractor 4.3 "*HITCHING TO TRACTOR*". Start the tractor engine, check all systems and test the mower before beginning work. In order to inspect:

- ➡ connect the mower to tractor,
- ➡ connect PTO shaft to tractor and mower,

- ➔ set mower in working position,
- ➔ start tractor PTO slowly

ATTENTION



Before using the mower always check its technical condition. In particular check the technical condition of the cutting unit, drive system, and integrity of protective guards.

Never start the PTO when the mower is raised.

Discs and cutting blades work at high rotation speed and even the smallest damage may cause an increase in vibration, which after a certain time shall result in fractures and cracks.

Leave for several minutes working at low RPM, during which check:

- that there is no knocking or noise in the drive system arising from scraping or grinding of metal elements,
- whether there is excessive vibration in the cutting unit,
- if the discs on the cutterbar rotates smoothly without any faltering,
- synchronised rotation of cutting unit.

The mower's operation without load should be smooth. Shaking of cutting unit and whole machine is not acceptable, nor is changed noise and vibrations coming from loose nut and bolt connections. After stopping mower check fastening of cutting blades. Check that gear oil does not leak from reduction gear and cutterbar.

DANGER



Before using the mower, the user must carefully read this operator's manual.

Careless and improper use and operation of the mower, and non-compliance with the recommendations given in this operator's manual is dangerous to your health.

The mower must never be used by persons, who are not authorised to drive agricultural tractors, including children and people under the influence of alcohol or other drugs.

Non-compliance with the safety rules of this Operator's Manual can be dangerous to the health and life of the operator and others.

Before starting the mower, make sure that there are no bystanders in the danger zone.

If any faults are detected they must be identified and rectified. If a fault cannot be rectified or the repair could void the warranty, please contact retailer for additional clarifications.

4.2 CHECKING TECHNICAL CONDITION OF MOWER

When preparing the mower for normal use, check individual elements according to guidelines presented in table (4.1).

TAB 4.1 Technical inspection schedule

DESCRIPTION	SERVICE OPERATION	FREQUENCY OF INSPECTIONS
Operation of hydraulic system	Check the tightness of lines and proper operation of hydraulic cylinders.	Daily
Check that the cutting blades, mounting pins and discs are in good technical condition.	Visually inspect and if necessary replace damaged parts.	
Check oil level in intersecting axis gears	For details please refer to section "DRIVE SYSTEM OPERATION"	
Check oil level in cutterbar	For details please refer to section "CUTTERBAR OPERATION"	
Check tightness of securing nuts and bolts	Torque values should be according to table (5.5)	Every three months
Lubrication	Lubricate elements according to guidelines presented in section "LUBRICATION".	According to table (5.3)

	<p>ATTENTION</p> <p>Do NOT use unreliable mower.</p> <p>Prior to connecting hydraulic system lines the user must carefully read the tractor operator's manual and observe all recommendations of the Manufacturer.</p>
---	---

4.3 HITCHING TO TRACTOR

The mower combination may only be mounted on a tractor fulfilling the requirements contained in table 1.1 "AGRICULTURAL TRACTOR'S REQUIREMENTS".



ATTENTION

Before using the mower, the user must carefully read the tractor operator's manual.

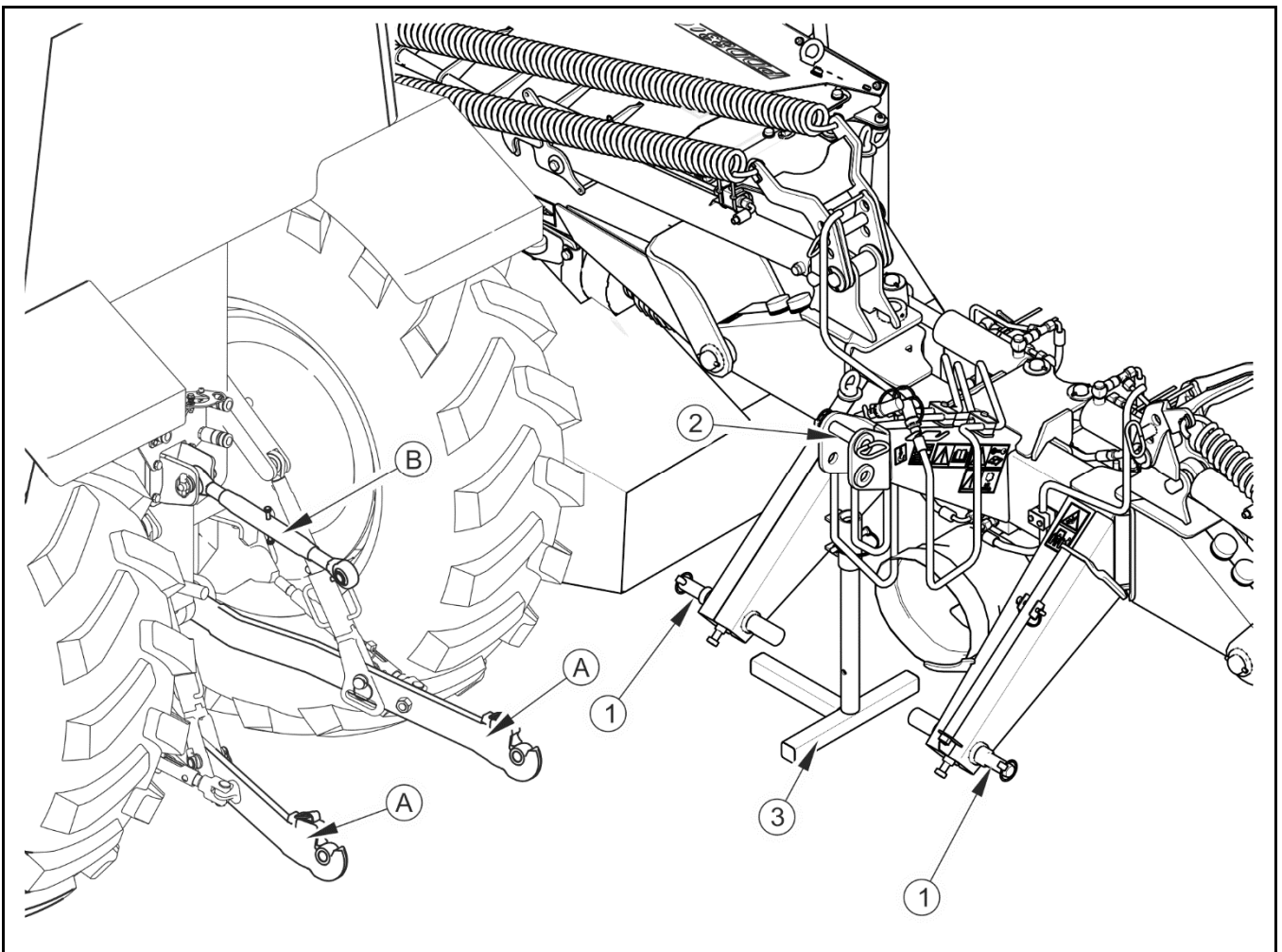

FIG. 4.1 Hitching to tractor

(A) three point linkage arms, (B) central connector, (1) lower pin, (2) central connector mounting pin, (3) support leg

In order to attach the mower to tractor, proceed as follows:

- ➔ Reversing the tractor bring the lower three point linkage connection points (A) of the tractor close to pins (1) of the mower.
- ➔ Set the link arms at the appropriate height.
- ➔ Turn off tractor engine and prevent it from moving.
- ➔ Connect lower pins (1) with linkage arms (A) and lock with the aid of cotter pins,
- ➔ Connect central connector (B) of tractor with pin (2) mower and lock with cotter pin.

Set both tractor lower linkage arms at the same height.



DANGER

**To hitch the machine to tractor use only genuine pins and safeguards.
When hitching, there must be nobody between the machine and the tractor.**

Lower pins (1) of the mower linkage enable spacing adjustment (*FIGURE 4.2*) in range 795 - 970 mm. To change spacing of linkage pins:

- ➔ Loosen counter nut (3),
- ➔ Unscrew setting bolt (2),
- ➔ Move pin (1) to the right or the left to obtain the required spacing,
- ➔ Block pin position with setting bolt (2) and counter nut (3)

The method of adjustment of right and left pins is identical.

As standard combination mower is equipped with pins for linking with category II linkage according to ISO 730. To adapt the mower for category III linkage, the optional pins should be used.

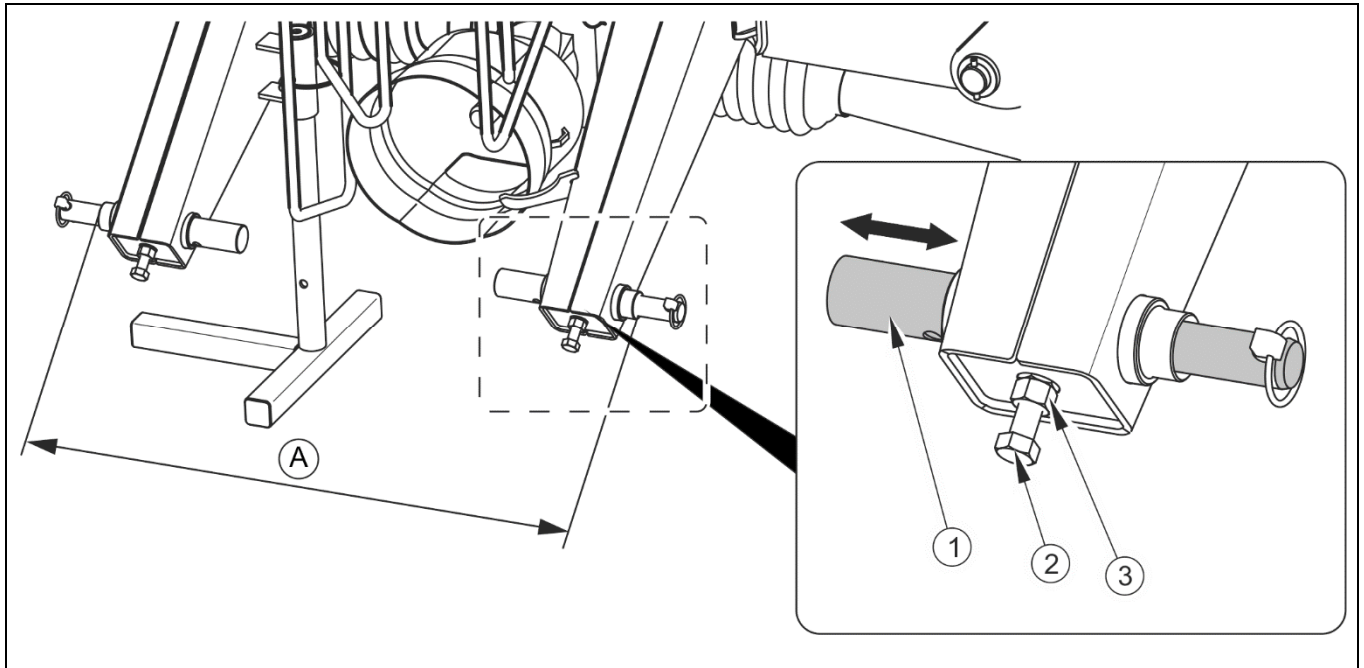

FIG. 4.2 Adjustment of mower lower mounting pins

(A) pin spacing in range 795 ÷ 970mm, (1) linkage lower pins, (2) retaining bolt, (3) counter nut

DANGER



When hitching, there must be nobody between the mower and the tractor. when hitching the mower, tractor's driver must exercise caution and make sure that nobody is present in the hazard zone.

Prior to connecting hydraulic system lines the user must carefully read the tractor operator's manual and observe all recommendations of the Manufacturer.

Line connections of the raising cylinders of the cutting unit lifting frames should be connected to the hydraulic circuit equipped with so-called "floating section". Line connections of tipping cylinders of the lifting frames should be connected to double acting hydraulic circuit.

DANGER



When connecting the hydraulic lines to the tractor, make sure that the tractor hydraulic system is not under pressure.

4.4 TRANSPORTING THE MACHINE

For transport to place of work and back, set mower in transport position (*FIGURE 4.3*) and raise tractor three point linkage so that the lower pins are at height of not less than 500 mm above the ground. Disconnect PTO shaft from tractor's PTO and place on support. When driving on public or private roads, respect the road traffic regulations, exercise caution and prudence.

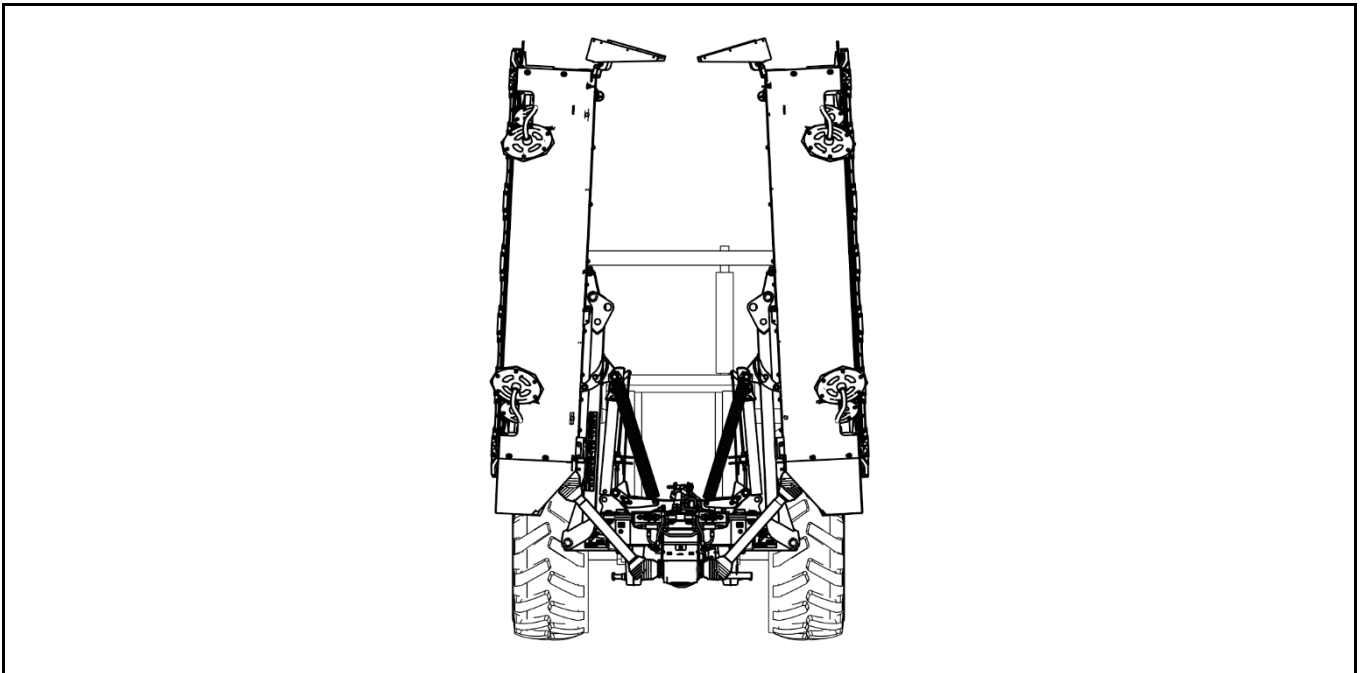

FIG. 4.3 Transport position

To prepare mower for transport (travel on roads) perform the following actions on the tractor:

- ➔ raise the mower lateral guards – figure (4.5),
- ➔ set hydraulic cylinder locks (1) and (2) in open position "I" - figure (4.4),
- ➔ using the appropriate tractor external hydraulic levers raise the lifting frame together with cutting unit until blocked by hydraulic cylinder lock (2).
- ➔ Secure lifting frame against falling by closing cut-off valve (2),
- ➔ lift mower on tractor lower linkage arms using three point linkage.

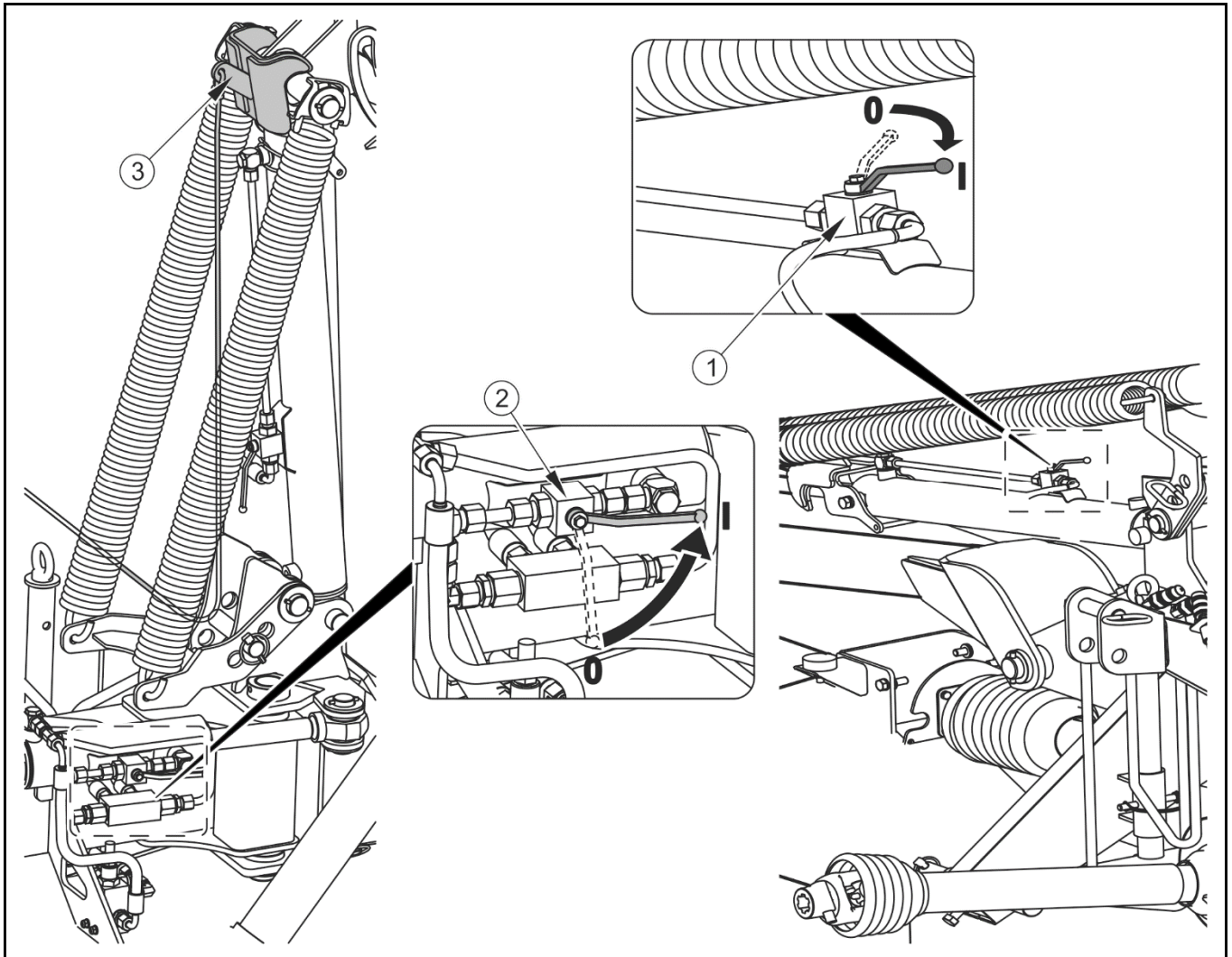

FIG. 4.4 **Setting transport position**

(1) *lifting arm hydraulic cylinder cut-off valve*, (2) *tipping cylinder cut-off valve*, (3) *cylinder lock*

To reduce height of mower in transport position open lateral guards (1) and lock in open position, *FIGURE (4.5)*. To open guards:

- ➔ release rotation catches (3), on both sides of mower.
 - ⇒ They are for connecting elastic guards,
- ➔ release and take out securing pin (2),
- ➔ raise lateral guards (1),
- ➔ secure guards open position (2) placing pin in appropriate bracket opening.

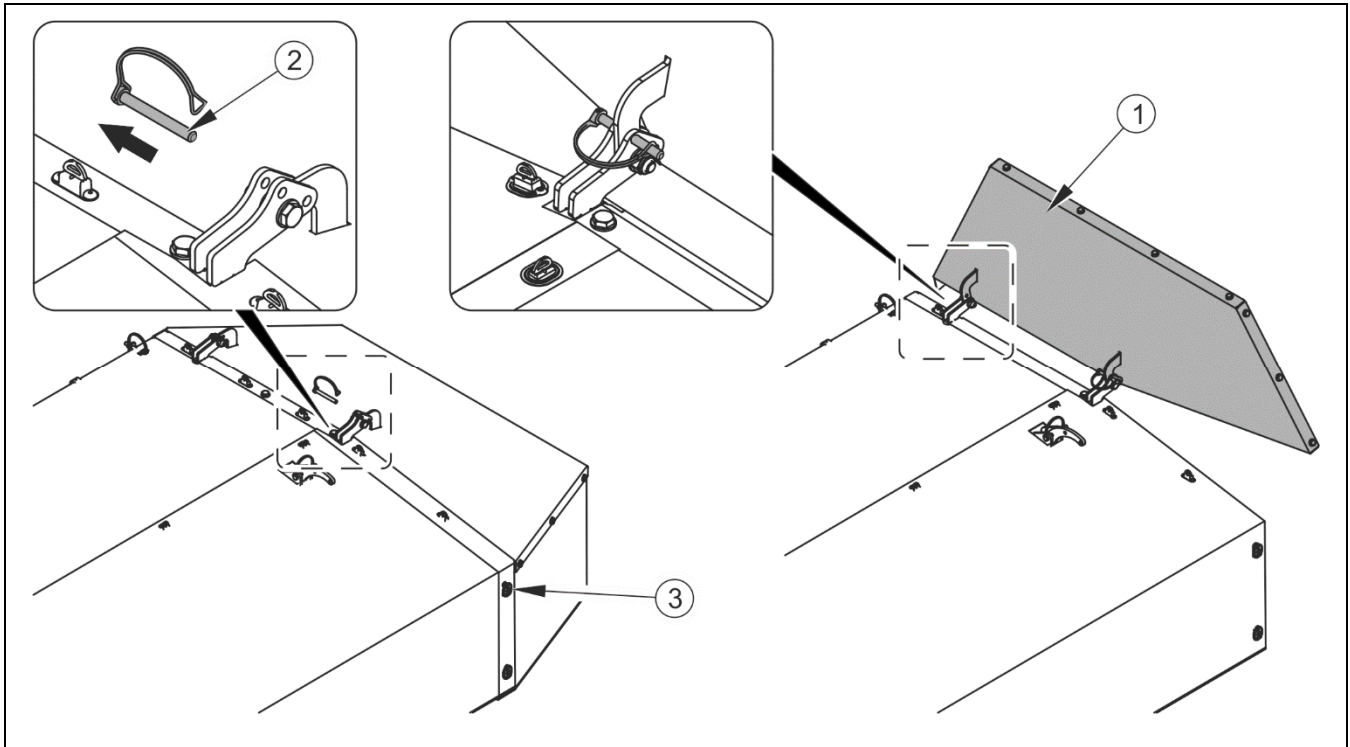

FIG. 4.5 Raising guards for transport

(1) side shield, (2) securing pin, (3) rotation catch

Listed below are the key guidelines for driving the tractor and mower combination.

- Transport on public roads and outside fields must always take place with raised machine.
- Before moving off make sure that there are no bystanders, especially children, near the mower or the tractor. Take care that the driver has sufficient visibility.
- Make sure that the mower is properly attached to the tractor, and that the PTO shaft is correctly secured.
- Permissible design speed and maximum speed allowed by road traffic law must not be exceeded. Travel speed should be adapted to the current road conditions.



ATTENTION

Do NOT travel with machine which has an unreliable brake, lighting or signalling system.

- Speed must be sufficiently reduced before making a turn or driving on an uneven road or a slope.

- Monitor mower's behaviour when travelling on an uneven terrain, and adjust driving speed to road conditions, slow down early enough when turning.

**DANGER**

Do NOT transport mower mounted on tractor with open hydraulic valves. Valves must always be set in position "0" - closed.

4.5 SETTING AND MOWING

4.5.1 SETTING WORKING POSITION

To work with the combination mower first set it appropriately. The machine cutting unit is capable of moving up and down in relation to the linkage frame. Such a solution enables the cutting unit to respond to unevenness of the mown field, when the linkage frame moves according to the movements of the tractor. For the mower to work optimally set it to the base position recommended by the Manufacturer. In order to set it:

- ➔ valves (1) and (2) tipping cylinders and lifting cylinders raising lifting arms should be set in open position "I"- figure (4.6),

**ATTENTION**

Before lowering lifting arms check that the space is clear and that there is nobody nearby.

- ➔ release locks (4) of lifting arm interlock by pulling cables (3) and by operating tractor hydraulic circuit, lower lifting arms with cutting unit so that the cutterbar is supported freely on the ground, set hydraulic circuit in float position,
- ➔ set tractor three point linkage lower links at height of A=400mm so that the pin is more or less in mid lock range (3) - figure (4.7).

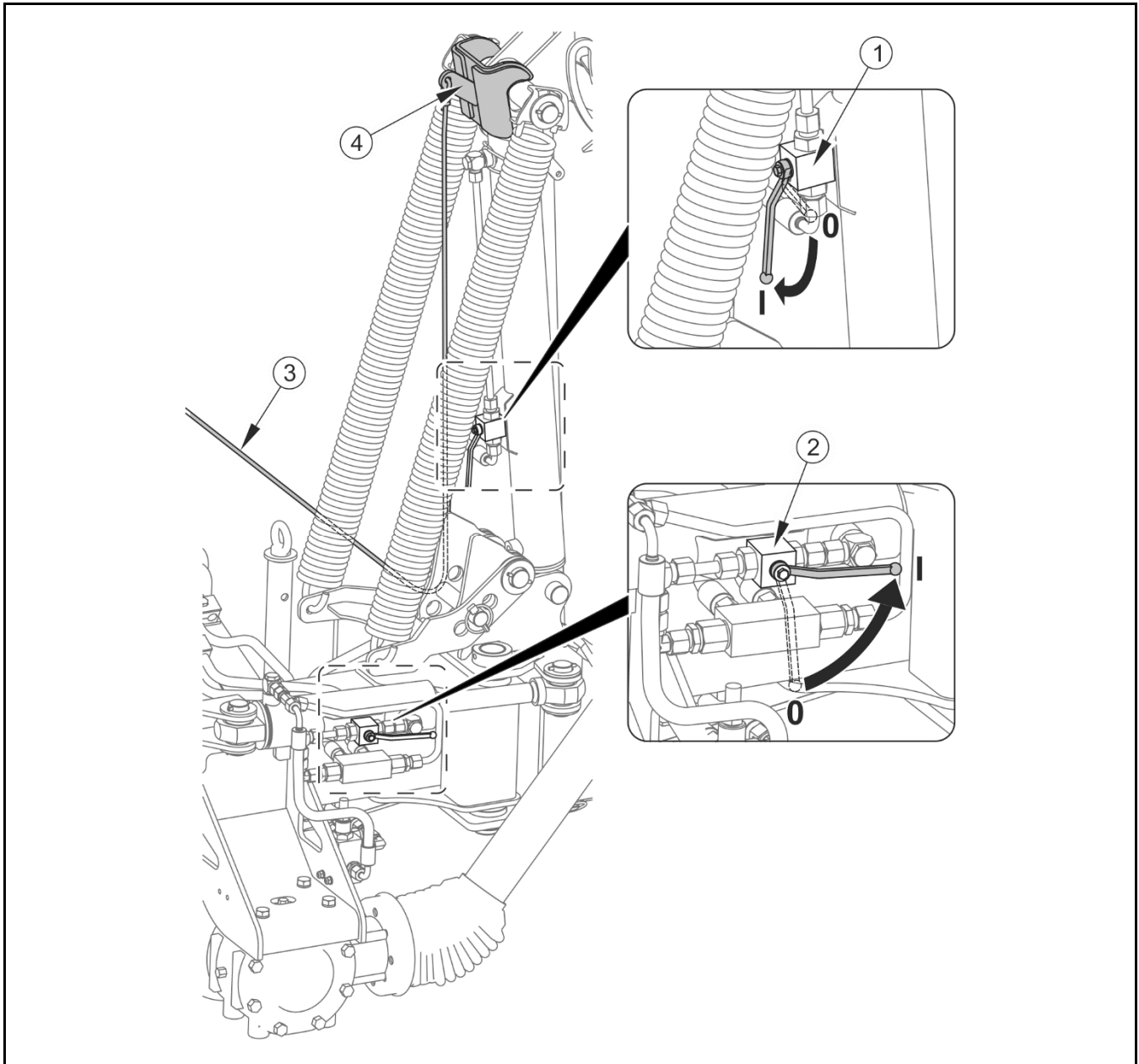

FIG. 4.6 **Setting mower in working position**

(1) lifting arm hydraulic cylinder interlock valve, (2) tipping cylinder interlock valve, (3) cylinder lock cable, (4) cylinder lock

4.5.2 CUTTING HEIGHT ADJUSTMENT

After lowering mower to the ground set cutting height. Changes of setting are made by shortening or lengthening the central connector (2) so that the angle (B) of inclination of cutterbar (1) is from 4° to 5°. Lengthening connector increases the cutting height and shortening reduces the cutting height.

**NOTE**

Optimum cutter bar inclination angle to the front is from 4° to 5°. Inclination to the rear causes faster wearing of cutterbar slide surfaces.

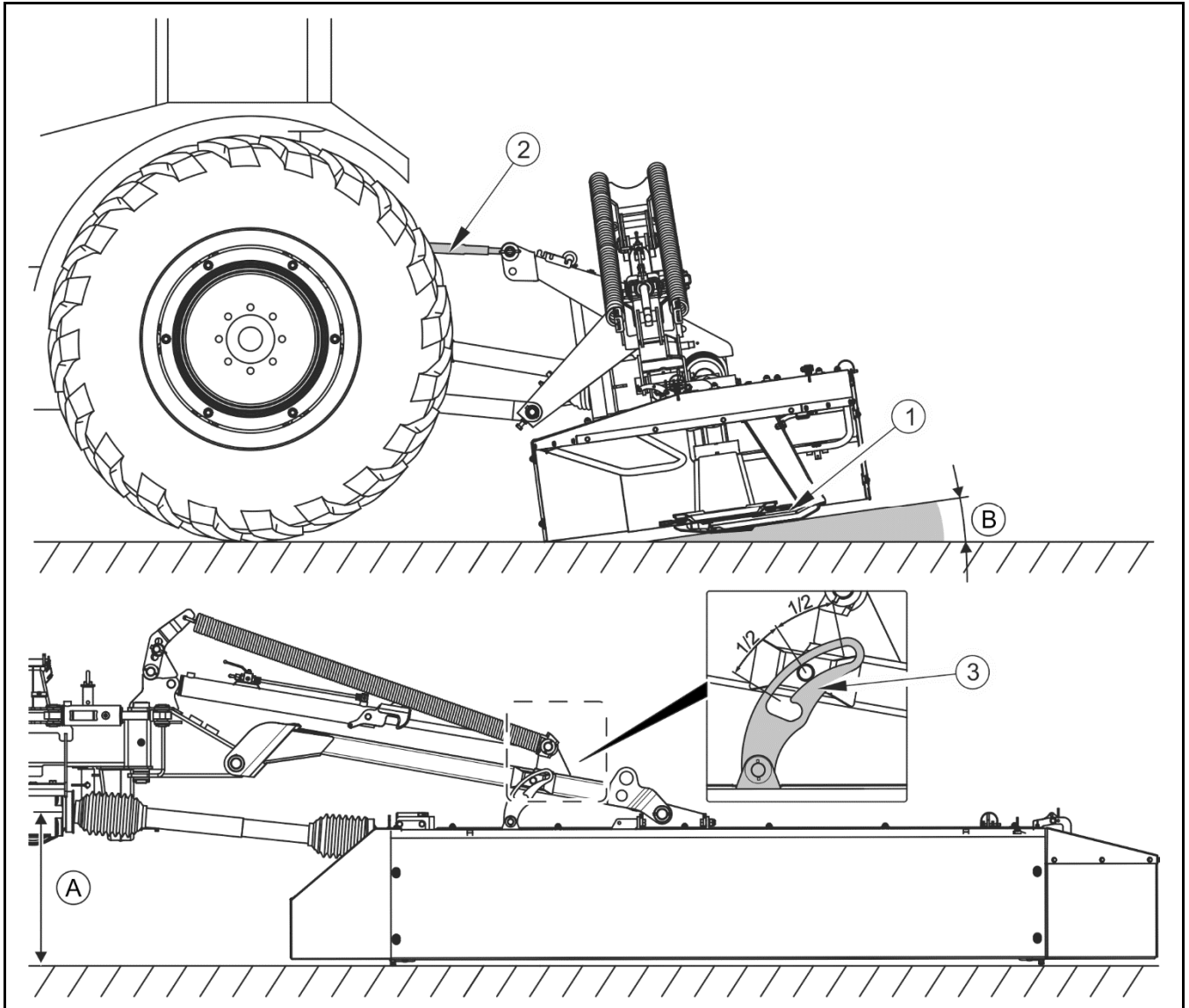

FIG. 4.7 **Setting cutting height**

(A) distance of lower link arms from ground - 400mm, (B) cutter bar inclination angle - 4÷5°,
(1) cutter bar, (2) central connector, (3) lock

4.5.3 ADJUSTMENT OF CUTTERBAR PRESSURE

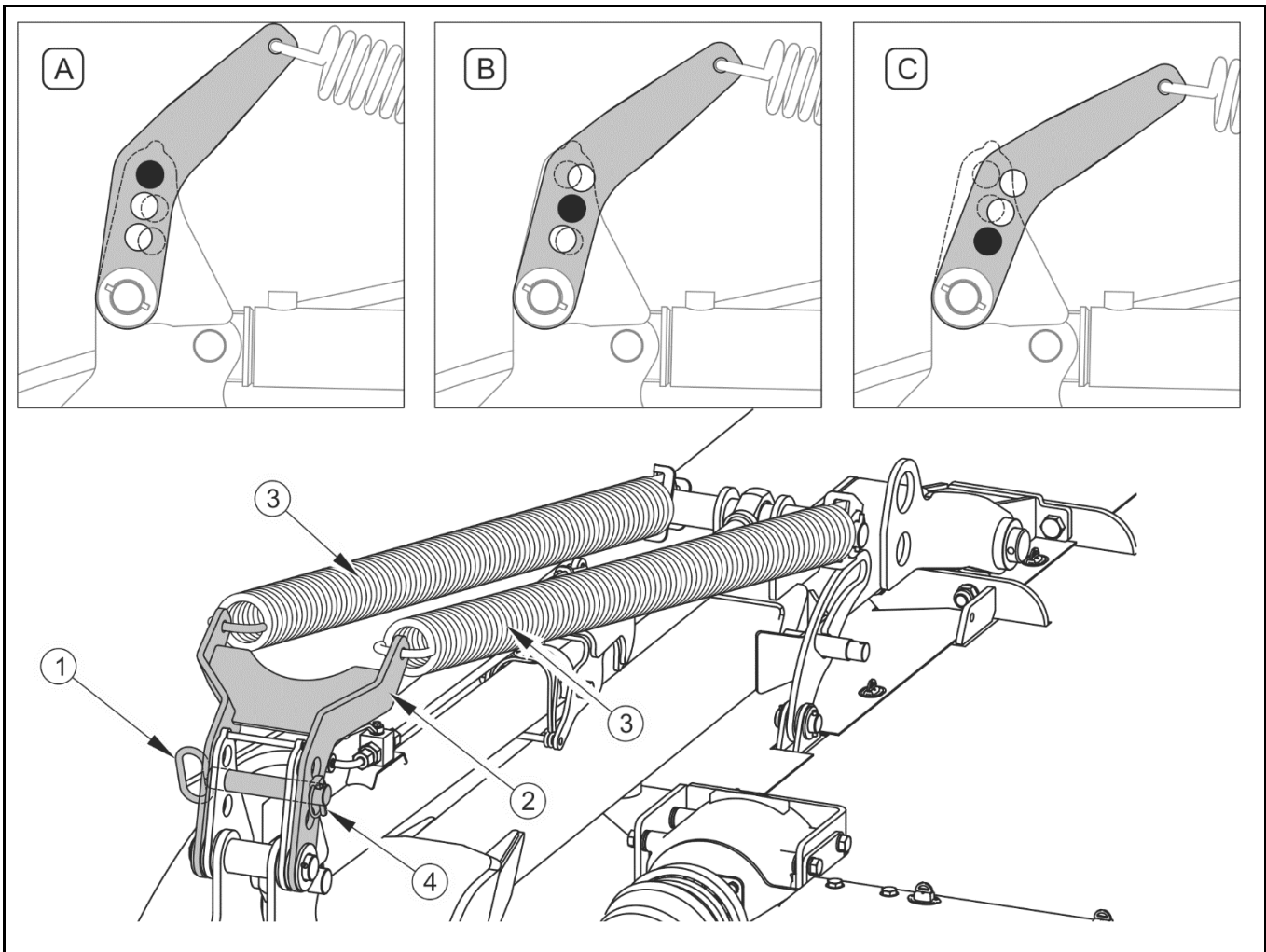

FIG. 4.8 Adjustment of cutter bar pressure

(A) pressure setting for 70kg, (B) pressure setting for 80kg, (3) pressure setting for 90kg, (1) locking pin, (2) spring bracket, (3) stay springs, (4) locking pin cotter pin.

In order to protect the stubble during cutting and reduce partial wear on slide skates of the cutting unit and also to ensure good ground surface tracking it is necessary to adjust the pressure of the cutterbar on the surface appropriately. The stay springs (3) are for this purpose. The pressure must be suitable to the ground conditions, the means of movement, type of surface and type of forage mown. Depending on the setting the pressure value on the surface may be 70, 80 or 90kg.

The loading is adjusted by changing the tension of both springs (3) on each arm separately. In order to make adjustment:

- ➔ raise the lifting arms of the cutting unit to reduce spring loading,

- ➔ remove securing cotter pin (4) and take out pin (1),
- ➔ set bracket accordingly (2), in order to enable insertion of pin (1) in appropriate opening (A, B, or C),
- ➔ secure the pin in the chosen position with cotter pin (4).



ATTENTION

Machine loading is set in a factory so that pressure on the soil is suited to work in normal conditions.

4.5.4 CONNECTING DRIVE SHAFT

Before proceeding to connect the mower it is essential read the PTO shaft operator's manual and observe the instructions it contains. In particular, check the condition and integrity of the guards and securing chains.



DANGER

Before connecting the shaft, turn off the tractor engine and remove the key from the ignition. Ensure that unauthorised persons do not have access to the tractor.

The use of PTO shaft and its technical condition must be in accord with the Operator's Manual of PTO shaft.



ATTENTION

Before first use, adjust the length of PTO shaft according to Operator's Manual of PTO shaft recommendations.



TIP

Adjustment of the PTO shaft applies only to a specific type of tractor. If the machine is connected to a different type of tractor, the adjustment procedure for this type of tractor should be possibly carried out.

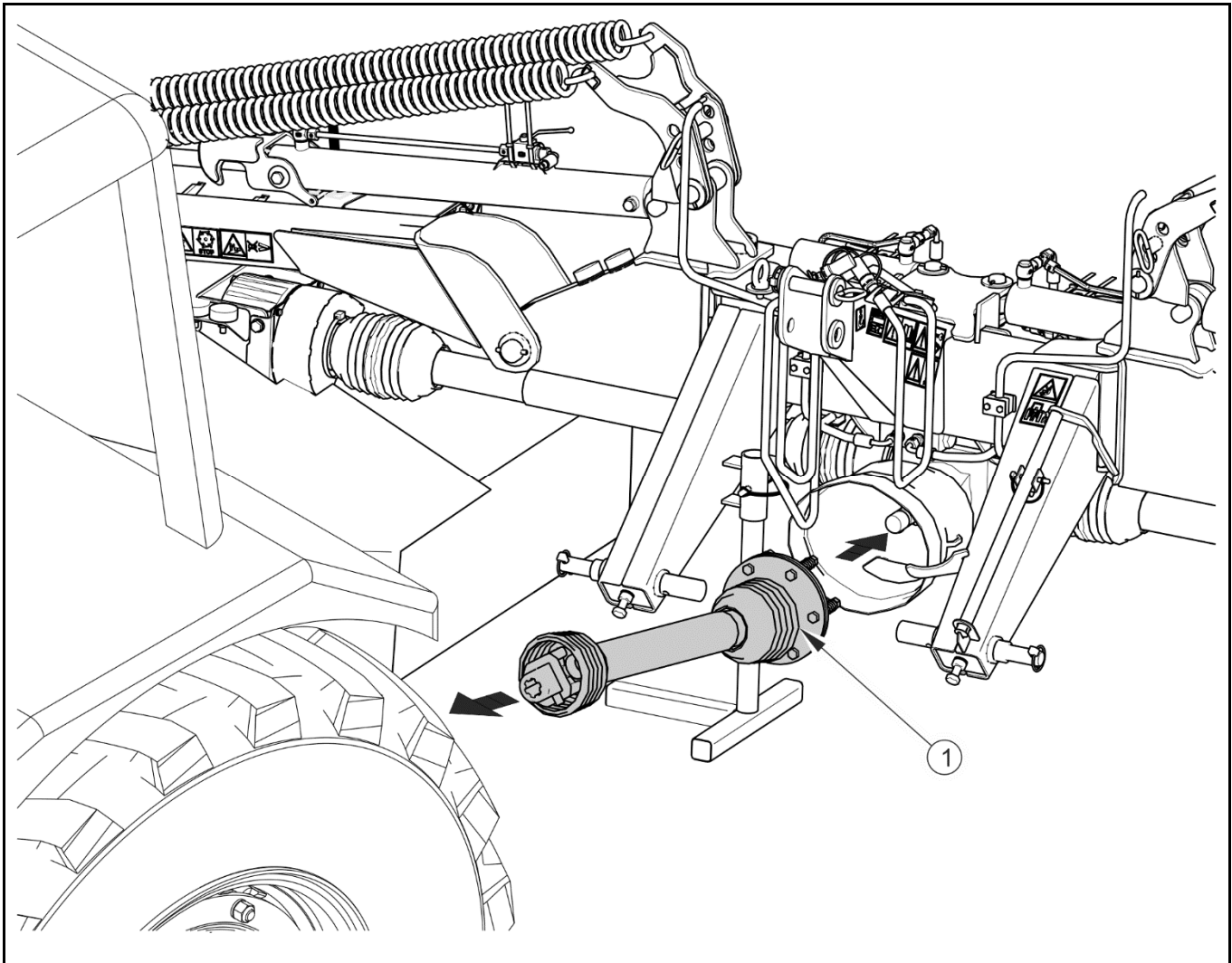

FIG. 4.9 Connecting of PTO shaft

(1)- PTO shaft backstop overload release clutch

The PTO shaft, which connects PTO of the tractor with the mower's central transmission and is equipped with an overload and backstop clutch. Connecting the shaft it is necessary to connect the end of the shaft fitted with the clutch to the mower side - figure (4.9). The value of the transferred torque on the shaft is set by the Manufacturer and may not be changed independently. Change of overload protection clutch setting may invalidate the warranty

PTO shaft collecting both intersecting axis gears does not require installation or dismantling.

4.5.5 SETTING THE SWATH WIDTH IN PDD830 MOWER

Before proceeding to mowing, set the swath width so that the cut grass is not crushed by the tractor wheels.

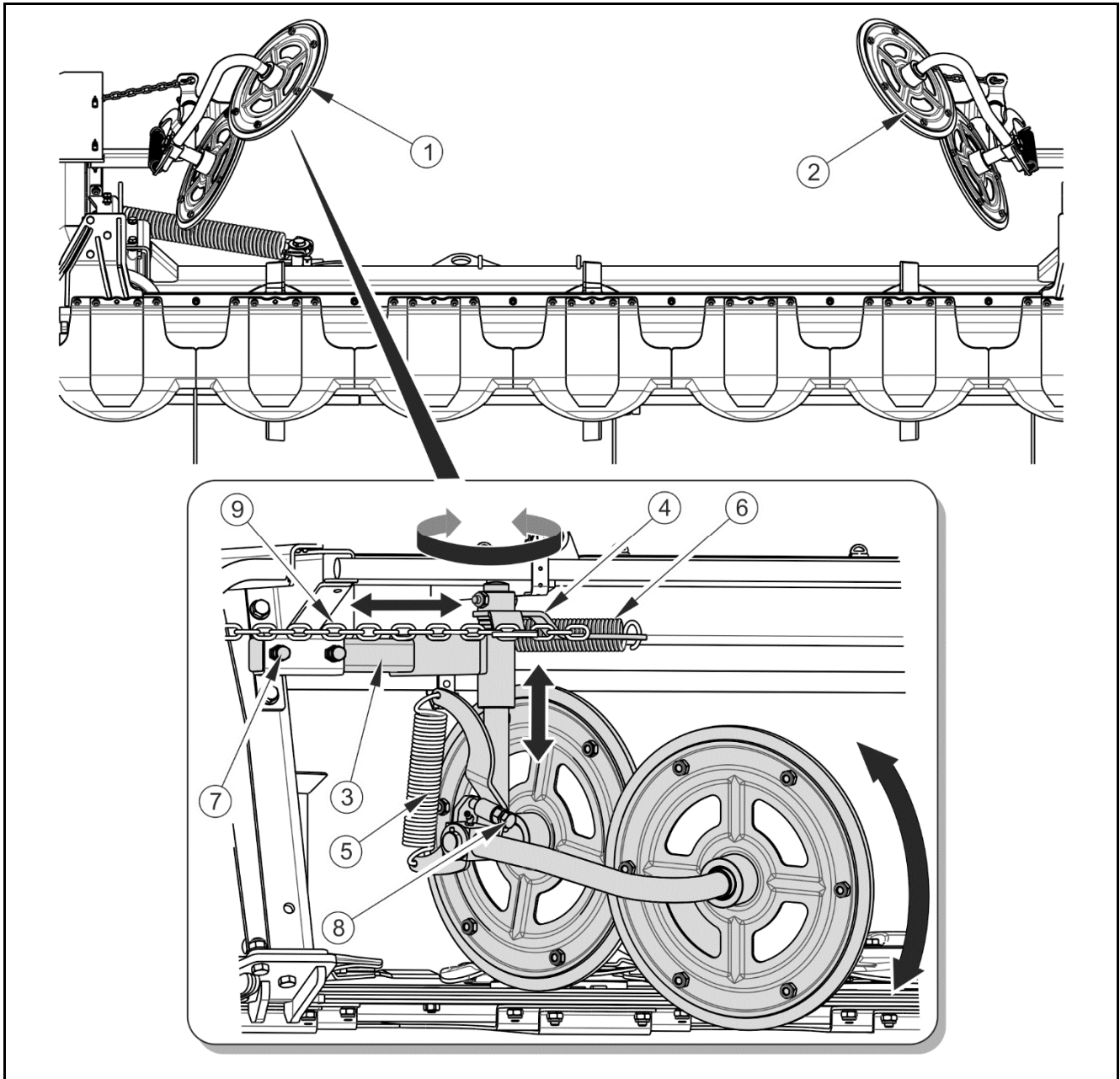

FIG. 4.10 Settings swath width

(1) swath guide left (2) swath guide right, (3) swath guide arm, (4) head, (5) vertical plane swath guide assembly shock absorbing spring, (6) horizontal plane swath guide assembly shock absorbing spring (7) arm adjustment bolt (8) vertical plane spring tension adjustment bolt, (9) limiting chain

DANGER

When adjusting swath guides exercise caution as there is a risk of crushing fingers with spring tensioned mechanisms.

After completing the adjustments make sure all bolt connections are tight and the range of swath guides motion is correct. The mower may only be started when all guards are in place.

You may adjust the swath width smoothly within 1 200÷2 000 mm by adjusting the two swath guides as appropriate.

In order to adjust swath guide horizontally:

- ➔ loosen counter nuts and adjustment bolts (7),
- ➔ move arm (3) as required, tighten bolts (7) and secure with counter nuts,

Besides the adjustment of the guide unit operating width you may also adjust the dampening scope of the spring (6) in the horizontal plane, which also affects the swath width. To this end, adjust the length of the limiting chain (9) as appropriate by attaching it in the head (4) fastening hole at the right length (4). When fitted, secure the limiting chain against slipping out of the head.

Follow the same procedure to adjust the second swath guide for this cutterbar, and swath guides for the other cutterbar. In the event of a blockage, set the widest swath.

4.5.6 SETTING THE SWATH WIDTH IN PDD830C MOWER

Two swath guides installed on the conditioner unit support frame are used to adjust the swath width.

You may adjust the swath width smoothly within 1 500 ÷ 2 300 mm by adjusting the two swath guides (1) as appropriate. To adjust swath guide position:

- ➔ loosen the adjusting screw (3) in the kidney slot of the bracket (4) at the swath guide (1),
- ➔ rotate swath guide (1) setting the appropriate swath width, and tighten the adjusting bolt (3) in the kidney slot,

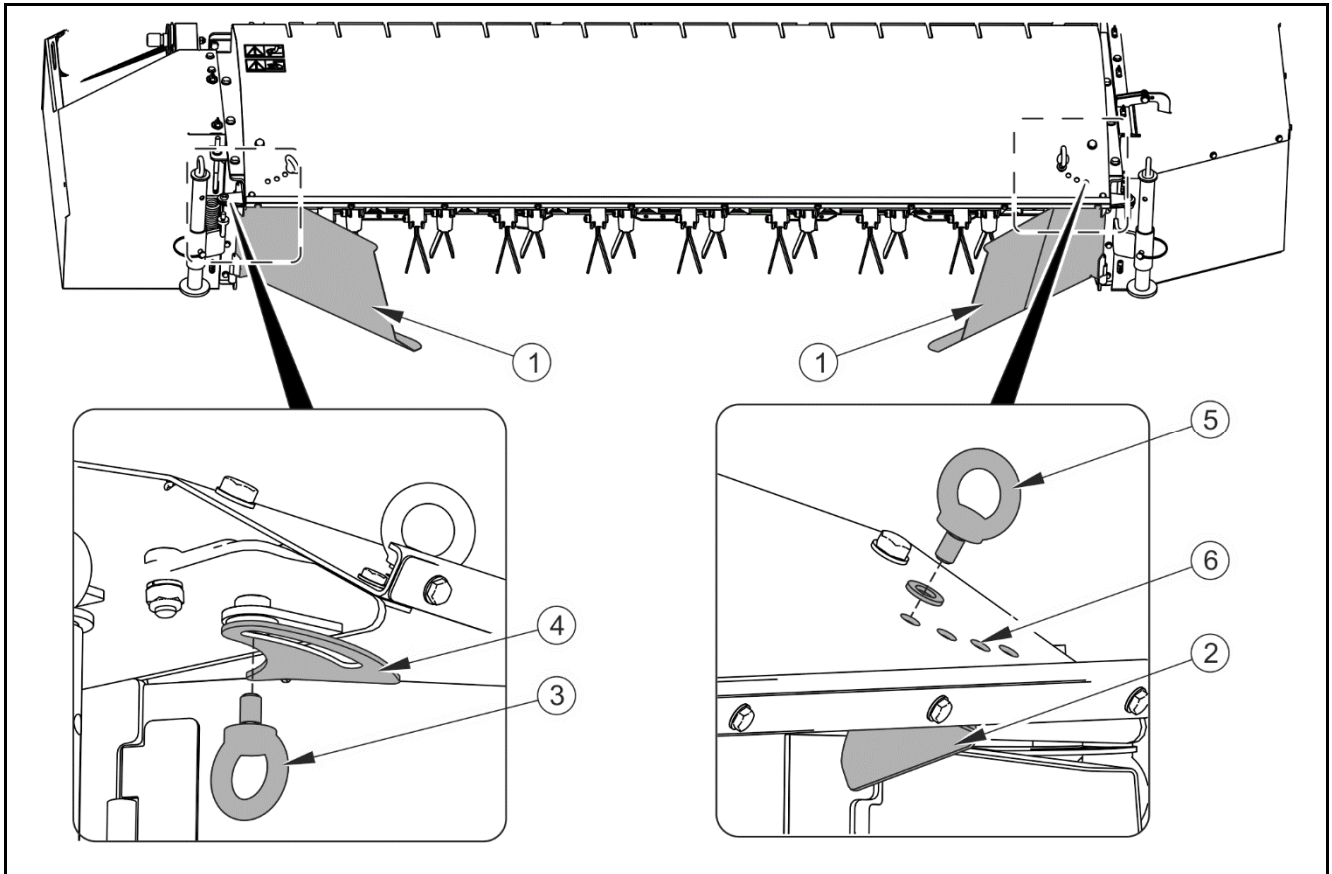

FIG. 4.11 Settings PDD830C swath width

(1) swath guide, (2) swath blade, (3) swath guide adjustment bolt, (4) swath guide bracket with a kidney slot; (5) swath blade adjustment bolt, (6) swath blade adjustment openings.

Then adjust the setting of swath blade (2) appropriately to the swath guide (1) so that the mown materials is directed to swath guide. In order to do this:

- ➔ unscrew the adjusting screw (5),
- ➔ set swath blade (2) as required so that its opening is in line with the opening (6) in conditioner body
- ➔ tighten the adjusting screw (5) in the selected hole (6).

Proceed the same way with the opposite swath guide and swath blade. Perform all adjustments for the other cutterbar.

4.5.7 SET THE CONDITIONING INTENSITY IN THE PDD830C MOWER

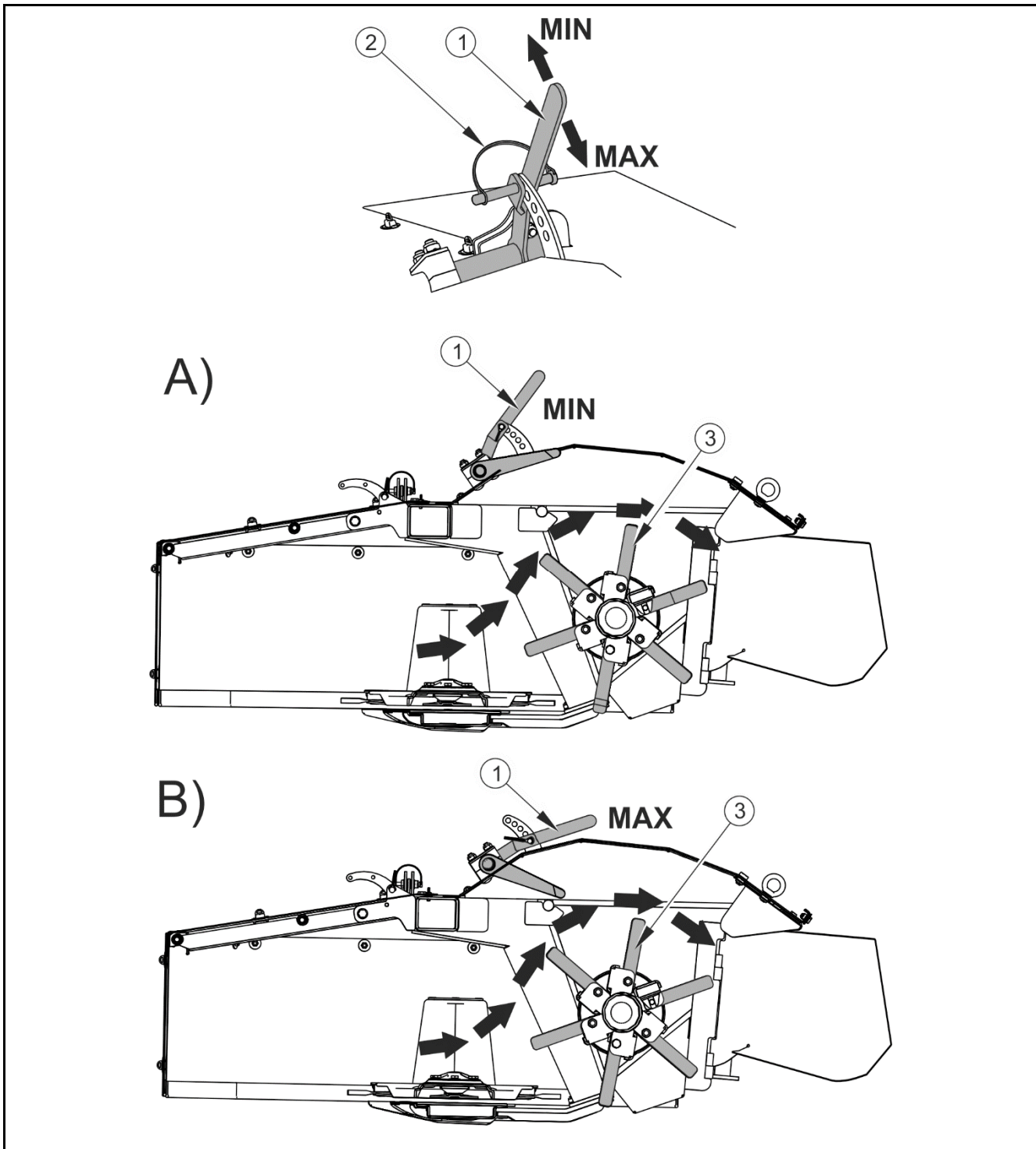

FIG. 4.12 Settings PDD830C swath width

A- minimum swath conditioning intensity setting; B- maximum swath conditioning intensity setting; (1) - swath conditioner adjustment lever, (2) - cotter pin, (3) - swath conditioner flail blades

Depending on the type and density of the mown material, you can set the intensity of swath conditioning - figure (4.12). This is done by the lever (1) on the support frame of the conditioning assembly connected to the damping fingers. The damping finger must be adjusted so that the mown material does not collect between the cutterbar and conditioning shaft.

To adjust swath conditioning intensity:

- ➔ release and remove the securing cotter pin (2),
- ➔ move the adjustment lever (1) down to achieve a greater mown material conditioning intensity (MAX) or up to reduce the conditioning intensity;
- ➔ adjust the lever so that the hole in the lever is in line with a hole in the bracket;
- ➔ insert cotter pin (2) in the hole and secure it.

4.5.8 MOWING

After setting mower in working position, setting cutter bar and stay springs inclination angle, observe the following procedure:

- ➔ at low engine RPM connect PTO drive,
- ➔ gradually increase RPM until reaching 1000 rpm for PTO,
- ➔ engage appropriate tractor gear and drive into standing crop.

During mowing the lever controlling the cutting unit's hydraulic lifting circuit should be set in "floating" position, however the lever controlling arm inclination (hydraulic safety device) should be set in neutral position. cutting speed should be adjusted to the existing conditions that is the density of the crop, and the type of ground surface, on which one is cutting. The driver must always have the tractor under control and avoid unevenness and foreign bodies in front of the tractor and machine. On hilly terrain the working speed should be reduced and the driver must pay attention to movements of the machine in relation to the ground surface.

ATTENTION



If the machine is in the working position and cuts, the lifting arm cylinders must always be set in floating position so that the cutting unit may move freely tracking the ground contours optimally.

Never start the PTO when the mower is raised.

On uneven ground there is a risk of the machine colliding with mounds of soil or foreign bodies and the driver must minimise the risk of damaging the machine.

During crossing over swaths with the mower and during turning the mower cutting unit must first be raised with hydraulic cylinders and the number of revs and ground speed must be reduced. Travel speed must be reduced if:

- mown ground is uneven,
- crop is laid, or very tall and dense,
- there is a great risk of running into foreign bodies e.g. stones, branches and heaps of soil.

If during cutting the overload release clutch of the drive shaft is activated, disconnect PTO drive in tractor and check what caused the overload. The overload release clutch may be activated because of clogging or too low rotation speed of cutting unit.

In order to remove the cause of machine clogging you need to lower the cutting unit, turn off the PTO, turn off the engine, remove the key from the ignition and take special care.

DANGER



Along banks, ditches and furrows always be especially careful and reduce speed because of the possibility encountering foreign bodies and because of soil differences on the edges of banks and furrows. Not reducing speed may cause the soil to slip and the tractor and machine to overturn.

HIGH NOISE LEVEL WARNING



Depending on the working conditions, the tractor (implement carrier) with the machine may generate noise exceeding the level of 85dB at the driver position. In such conditions the driver should apply individual protection (protective ear guards).

In order to reduce the level of noise during work the tractor cab window and door should be closed.

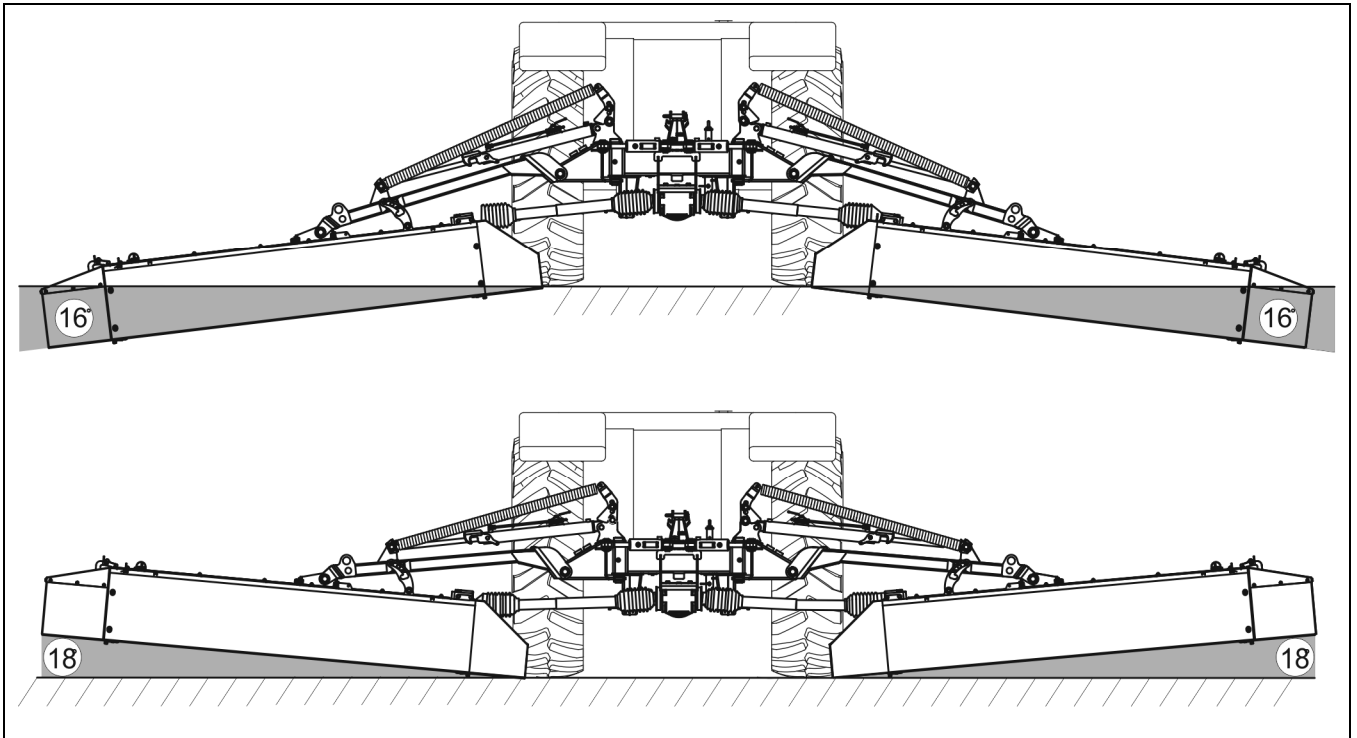

FIG. 4.13 Range of inclination of cutting unit

The mower is equipped with a hydraulic safety device, which protects the machine against damage resulting from collision with obstacles. When colliding with an obstacle the lifting arm rises and swings backwards. After passing the obstacle the cutting unit returns to the horizontal position and swings forward using the lifting arm inclination hydraulic cylinder. In order to enable action of the hydraulic safety device, both cylinder valves on each lifting arm should be set in open position.

ATTENTION



The machine design does not allow reversing with the machine in working position.

During cutting always maintain constant RPM speed of 1000 rpm for optimum cutting performance. If RPM speed falls the drive loading increases significantly and it may occur at the friction clutch would be activated to protect the system. In such a situation always disconnect the drive and check the cause of the overloading.

Give special attention to sudden movements and impacts in the cutting unit. After a strong impact was an obstacle always check the machine in case of possible damage. Damaged elements must be replaced.

4.6 DISCONNECTING FROM TRACTOR

Disconnect the mower and store horizontally on paved ground. Must be supported on the support leg and cutterbar, while PDD830C mowers on the conditioner supports.

DANGER



Before disconnecting tractor from mower check that the machine is protected against falling over.

Reduce pressure prior to disconnecting the hydraulic system.

During disconnection there must be nobody between the mower and the tractor.

Before lowering or raising the cutting unit ensure that nobody is near the machine and that nobody is doing any work that may be affected.

In order to disconnect the mower from the tractor proceed as follows:

- ➔ Release mower support foot and insert locking pin to secure it,
- ➔ lower mower using three point linkage to rest position,
- ➔ set lifting cylinder valves (1) in open position I- figure (4.6),
- ➔ release lock (4) of lifting arm interlock by pulling cable (3) and by operating tractor hydraulic circuit, lower lifting arms with cutting unit so that the cutterbar is supported freely on the ground, set hydraulic circuit in float position — figure (4.6)
- ➔ turn off tractor engine and remove key from ignition,
- ➔ reduce residual pressure in the hydraulic system by movement of appropriate lever controlling hydraulic circuit,
- ➔ disconnect hydraulic line connectors from tractor and secure with stoppers and place in special brackets on mower frame,
- ➔ disconnect PTO shaft from tractor's PTO drive and place on special bracket on mower frame,
- ➔ disconnect top link of three point linkage,
- ➔ disconnect mower pins from lower tractor linkage arms and drive away.

4.7 LIGHTING INSTALLATION AND ADDITIONAL SIGNAGE

4.7.1 CONSTRUCTION

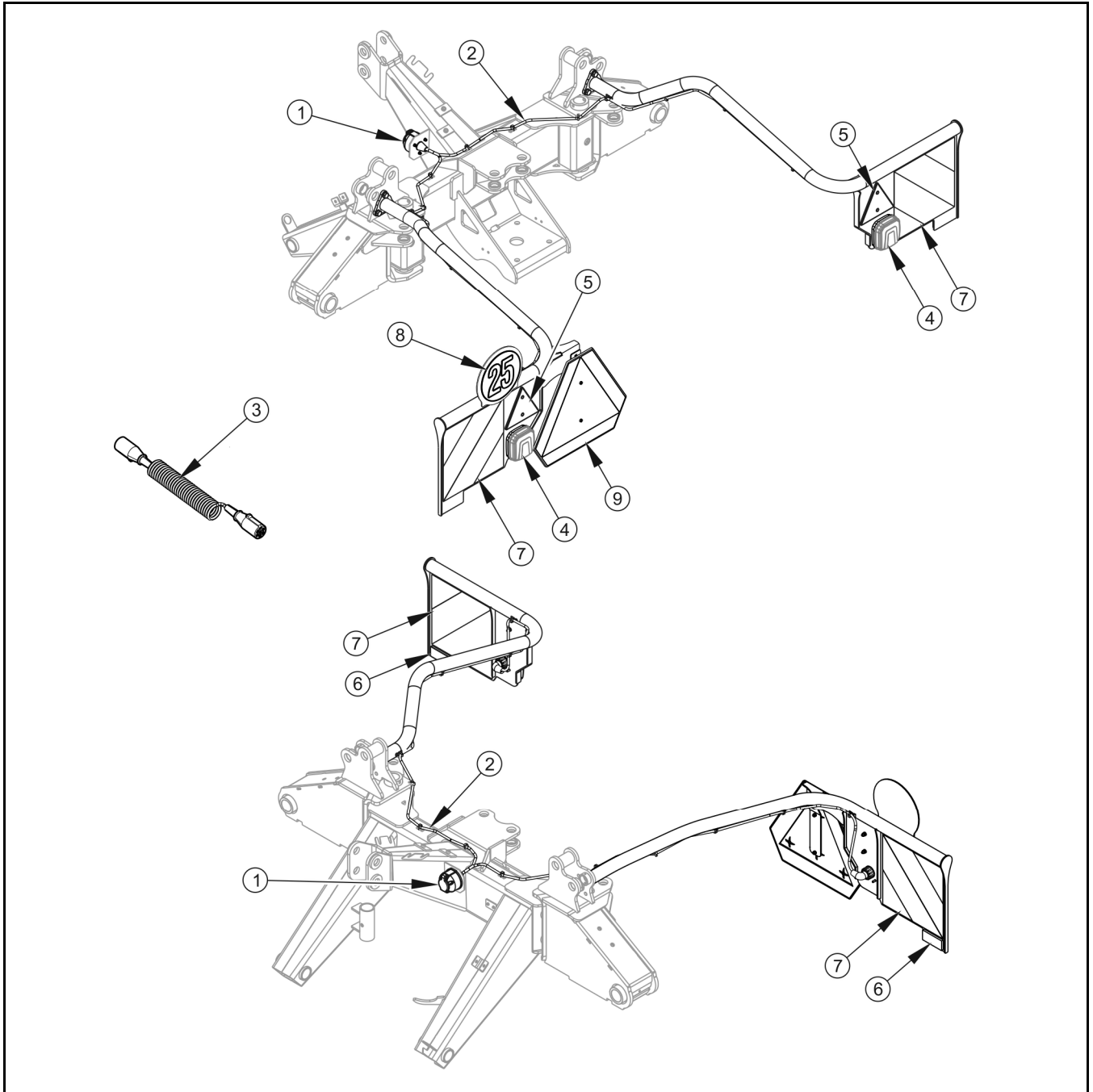



FIG. 4.14 Lighting installation and additional signage

(1) 7-pin electrical socket, (2) central harness, (3) 7-pin 12V spiral cable, (4) rear lamp assembly, (5) DOB-31 reflective triangle, (6) DOB-35 white rectangular reflector, (7) contour markings, (8) 25 km/h sticker (option), (9) warning board (option)

4.7.2 USE AND MAINTENANCE

The power supply to the lighting system of the machine requires the electrical installation of a tractor with a voltage of 12V with a 7-pin electrical outlet.

	ATTENTION
Driving with defective lighting installations is prohibited. Damaged lamps should be replaced immediately before driving off. Lost or damaged reflectors should be replaced with new ones.	
Before travelling, make sure that all lamps and reflectors are clean.	

Works related to the repair, replacement or regeneration of electrical installation components should be entrusted to specialized workshops that have appropriate technologies and qualifications to perform this type of work.

Your duties include only technical inspection of the electrical installation and reflectors.

The scope of service activities

1. Connect the lighting system of the machine to the tractor with a suitable electrical outlet.

	ATTENTION
If the tractor does not have the correct sockets or if the sockets are of a different type, have them installed by qualified personnel.	

2. Check the completeness, technical condition and correct functioning of the machine lighting.
3. Check the tractor connection socket and the cable plug on the machine.

	ATTENTION
A damaged body of the socket or plug of the electric cord qualifies for replacement.	

4. Check the the wiring harness for damage (rubbed insulation, wire break, etc.).

Before travelling on a public road, make sure that the tractor has a reflective warning triangle.

SECTION

5

MAINTENANCE

5.1 CHECKING AND REPLACING CUTTING BLADES AND PINS

Checking of cutting blades and securing pins must be conducted regularly. Visually inspect the blades and fixing bolts and check tightening torque of nuts. It is especially important after driving over or collision with foreign bodies, mounting new cutting blades and after first start-up of machine.

DANGER



Each time a blade hits an obstacle such as a stone or a branch, its technical condition must be inspected.

Before exchanging turn off the tractor engine, remove the key from the ignition, stop the tractor with parking brake and remove the PTO shaft. Ensure that unauthorised persons do not have access to the tractor. Cutter bar must rest on the ground.

Change cutting blades if:

- blades on the same disc have different lengths and weights,
- Are distorted,
- are very worn.

ATTENTION



In the event of the loss of a blade or its fragment, vibration may occur, which may damage the cutterbar.

Damaged or worn blades must be changed in pairs in order to maintain balance of cutting disc.

Before securing blades it is necessary to check the direction of disc rotation. Reverse setting shall cause impaired cutting.

Parts should always be replaced with original parts.

Securing pins should be replaced, if they are:

- heavily worn whose diameter is less than 15 mm,
- Deformed.

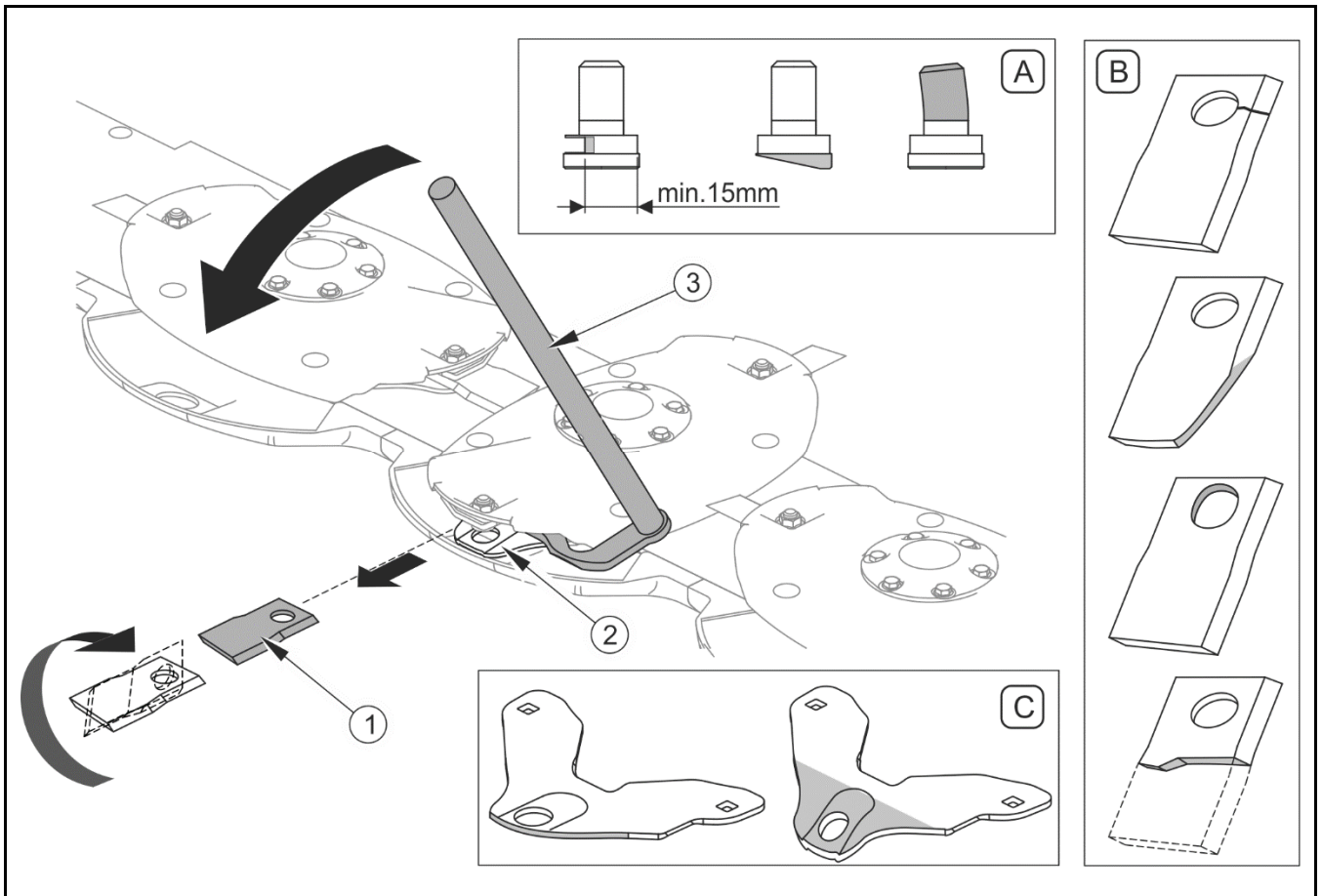

FIG. 5.1 Replacement of cutting blades

(1) cutting blade; (2) blade holder; (3) blade changing key; (A) example of damage to the cutting blade mounting studs; (B) example of blade damage; (C) example of blade holder damage

Use key to change parts (3) placing it between blade holder (2) and cutting disc, next press on key (3) till the moment that it is possible to take out the (1). When changing blades check the condition of the arbor securing the blade to the cutting disk and also the blade holder. An excessively worn or damaged arbor or blade holder should be replaced with a new part. Tighten arbor nuts with torque of 120 Nm.

Replace blades in pairs so that the disc balance is maintained. blades are two-sided; so that when they are not distorted they may be turned 180°, remembering the principle that the blade after cutting the grass flicks it upwards. The characteristics and dimensions of cutting blades used on mower are shown in table (5.1).

Rotation direction of individual discs is shown on figure (3.4).

TAB. 5.1 Cutting blade characteristics

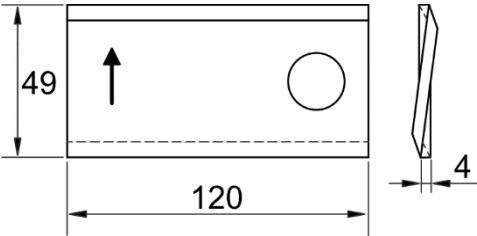
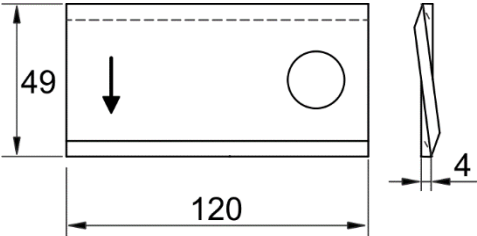
MARKING BLADE	DIMENSIONS [mm]	ROTATION DIRECTION	QUANTITY
BRZW 120/49/4 P		right	12
BRZW 120/49/4 L		left	16



ATTENTION
Use only CE certified blades meeting the requirements of ISO 5718 standard.

5.2 INSPECT AND REPLACE SWATH CONDITIONER FLAIL BLADES (PDD830C)

Regularly inspect beater fingers. Visually inspect beater fingers, their mountings and rubber blocks. Worn rubber blocks, distorted or broken fingers should be replaced. Fingers should be replaced in pairs to maintain balance.



DANGER
During inspection and replacement of beater fingers, turn off tractor engine and remove the key from the ignition and disengage PTO shaft. Rest conditioning assembly on the ground on parking stands.

To replace the flail blades:

- ➔ unscrew the M12 self-locking nut (6),
- ➔ remove the M12x55 fixing bolt (5),
- ➔ remove a pair of flail blades (1) from the lock (2).

When replacing the flail blades pay attention to the condition of the fixing bolt (5) and rubber block (3). Excessively worn or damaged bolt or rubber block should be replaced. Installation of the new flail blades should be performed in reverse order. Nut (6) of the fixing bolt must be tightened so that the flail blades (1) can move freely in the blade lock (2).

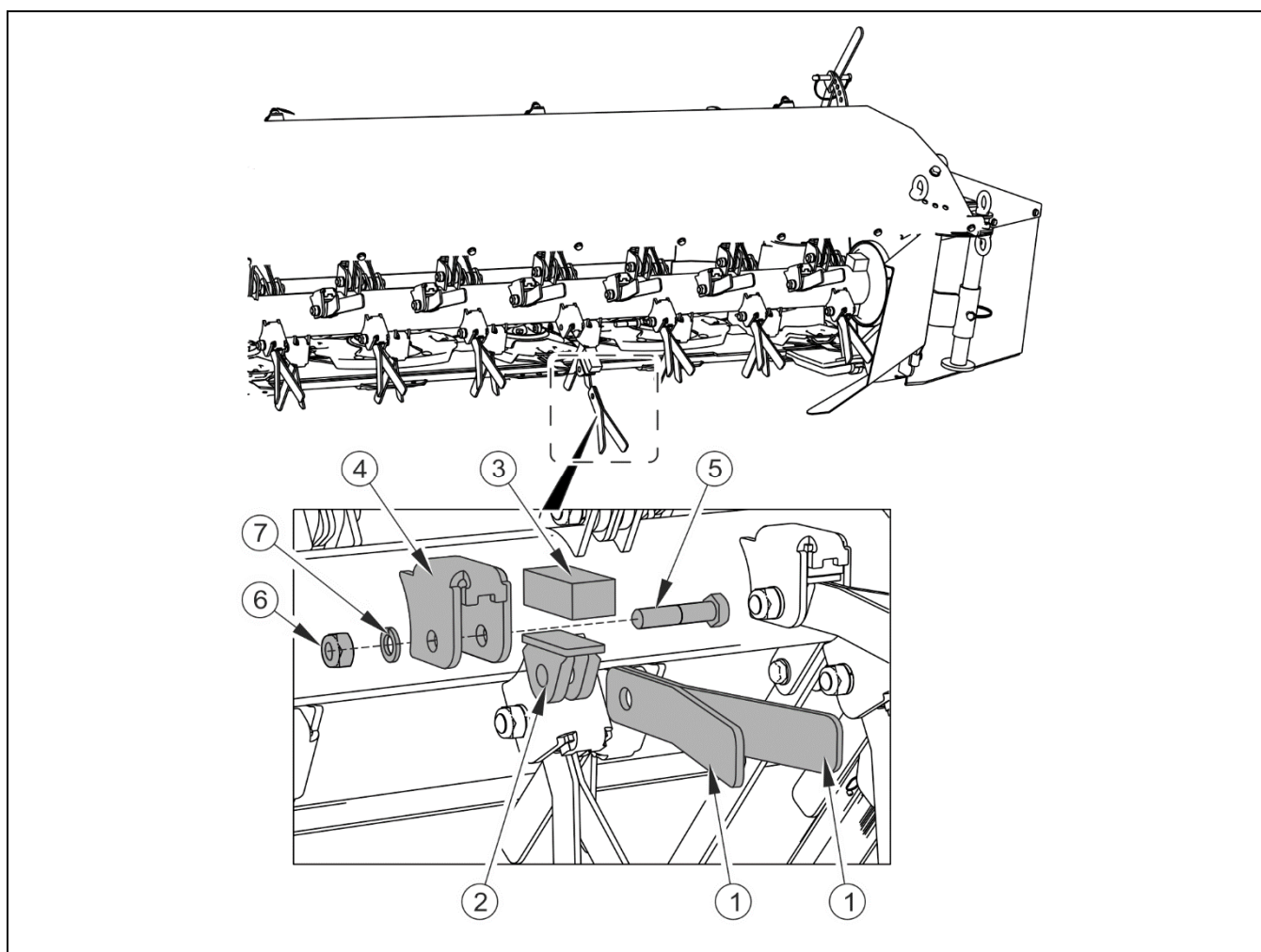

FIG. 5.2 Replacing the flail blades of the swath conditioner (PDD830C)

(1) flail blades, (2) blade lock, (3) rubber block, (4) blade mount (5) M12x55 kl.8.8 mounting bolt; (6) M12 kl.8.8 self-locking nut; (7) spring washer.

5.3 DRIVE SYSTEM MAINTENANCE

5.3.1 OPERATE TRANSMISSION

Drive system maintenance involves general checking of intersecting axis gears, change or supplementing transmission oil deficiencies. In the event of damage to transmission, contact authorised service point in order to perform repairs.

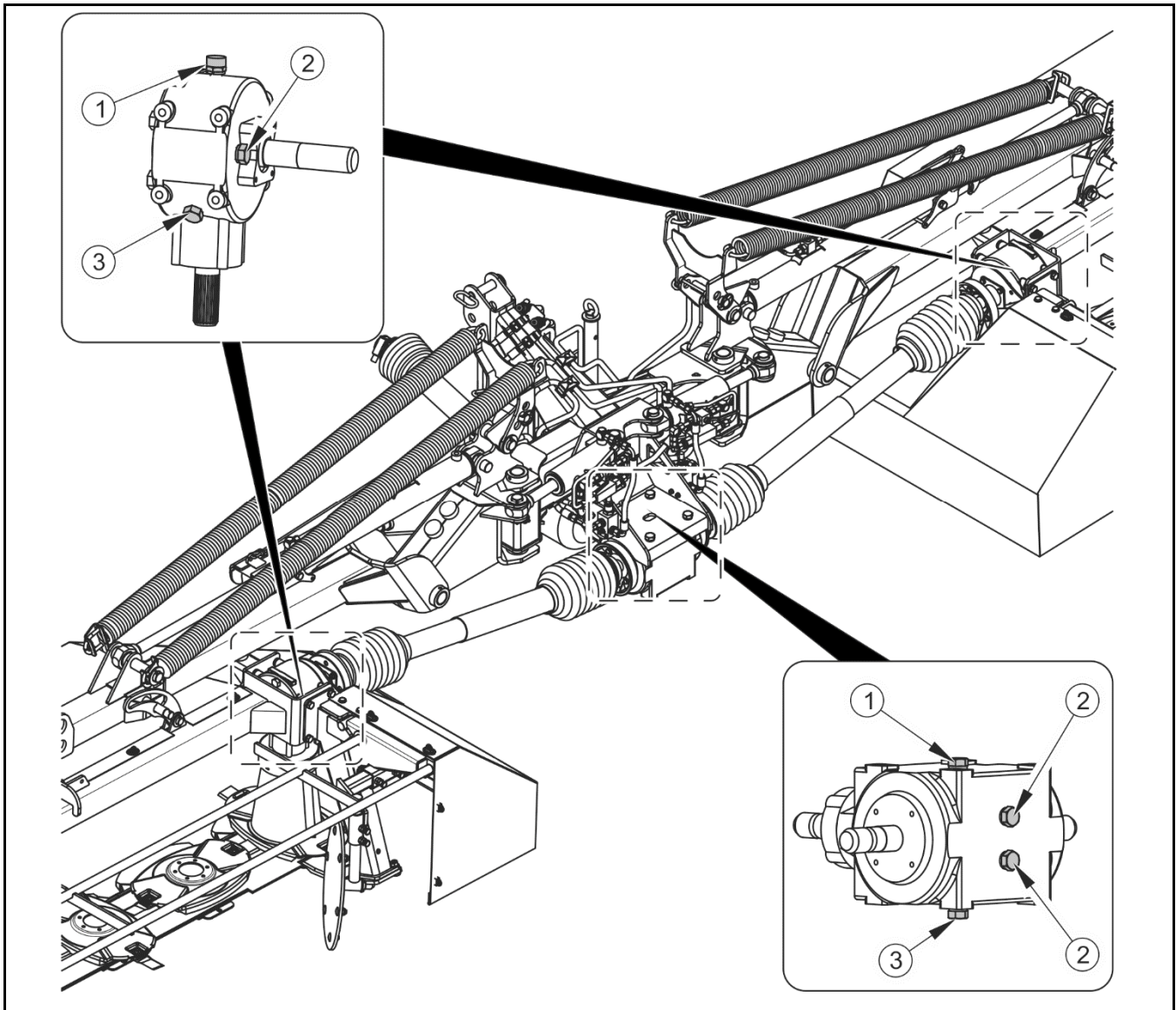

FIG. 5.3 Location and inspection points of intersecting axis gears

(1) filler plug, (2) inspection plug, (3) drain plug



Check oil level in intersecting axis gears daily.

To check the oil level in mower intersecting axis gears:

- ➔ set mower level horizontally,
- ➔ unscrew inspection plug (2),
- ➔ oil level should reach the lower edge of the inspection plug opening (2),
- ➔ if necessary, supplement oil through inlet opening (1) to the required level.



DANGER

Do not perform service or repair work under raised and unsupported machine.

In central transmission, check oil level on inspection plug (2) found below.

First oil change must be made after the first 50 hours worked. The next oil change should be made after 500 hours of mower work or once a year. Most suitable time for changing gear oil is when preparing for first fieldwork. On the mower three intersecting axis gears are mounted and their locations are shown on figure (5.3).

Transmission oil required: SAE 90EP (80W90 GL-5). The quantity of oil necessary to fill the central transmission is 2.5 litres, whereas lateral gear transmissions require 1.1 litres each.



Oil in intersecting axis gears must be changed after the first 50 hours of work. The next oil change should be made after 500 hours of work or once a year, whichever occurs first.

In order to change oil in gear transmission:

- ➔ set mower on a hard surface and level the machine
- ➔ unscrew filler plug (1),
- ➔ unscrew drain plug (3) on lower part of transmission,
- ➔ drain oil into tight oil resistant container,
- ➔ if oil Manufacturer recommends flushing transmission with washing detergent, that operation should be performed according to the guidelines of the oil Manufacturer,
- ➔ tighten drain plug (3),

- ➔ add oil until oil flows out of inspection plug opening (2), found on side wall of gear transmission.
- ➔ Tighten inlet and inspection plugs.

Used oil should be taken to the appropriate facility dealing with the re-use of this type of waste.

If a leak is noticed, carefully inspect seals and check oil level. Transmission operation with insufficient oil may cause permanent damage of the mechanism.

Repair of transmission during warranty period may only be performed at authorised mechanical workshops.

5.3.2 PDD830C BELT DRIVE TENSION ADJUSTMENT

In addition to periodic inspection of intersecting axis gears, swath conditioner mowers also require the monitoring of belt tension in swath conditioner belt drive.



DANGER

Before proceeding to check or adjust transmission belts, first turn off tractor engine, remove key from ignition and removed the PTO shaft.

To remove the front transmission cover to perform adjustment (2). To do this, unscrew the bolt (2) and nuts (5). Belt tension can be adjusted using the adjustment nut (10) screw (10) of the tensioner bolt (9). To do this, unscrew the locknut (11) and tighten the adjusting nut (10) on the bolt (9) to the point where the tensioner spring will be at a required tension. The deflection of the belt (1) measured at the mid point between the pulley on the intersecting axis gear and pulley of the conditioner shaft should not exceed 10 mm under the pressure of 7.5 daN (kg). If tension cannot be adjusted, replace belts for new ones.

There are three SPB 1525 belts in the transmission system. To replace v-belts, remove the PTO (3) transmission guard (1), then loosen the tensioner spring (7) with the adjustment bolt (10) and remove the belts from the pulleys. Check the swath conditioner unit belt tension after 2 hours of use. If necessary, tighten the belts according to the above guidelines.

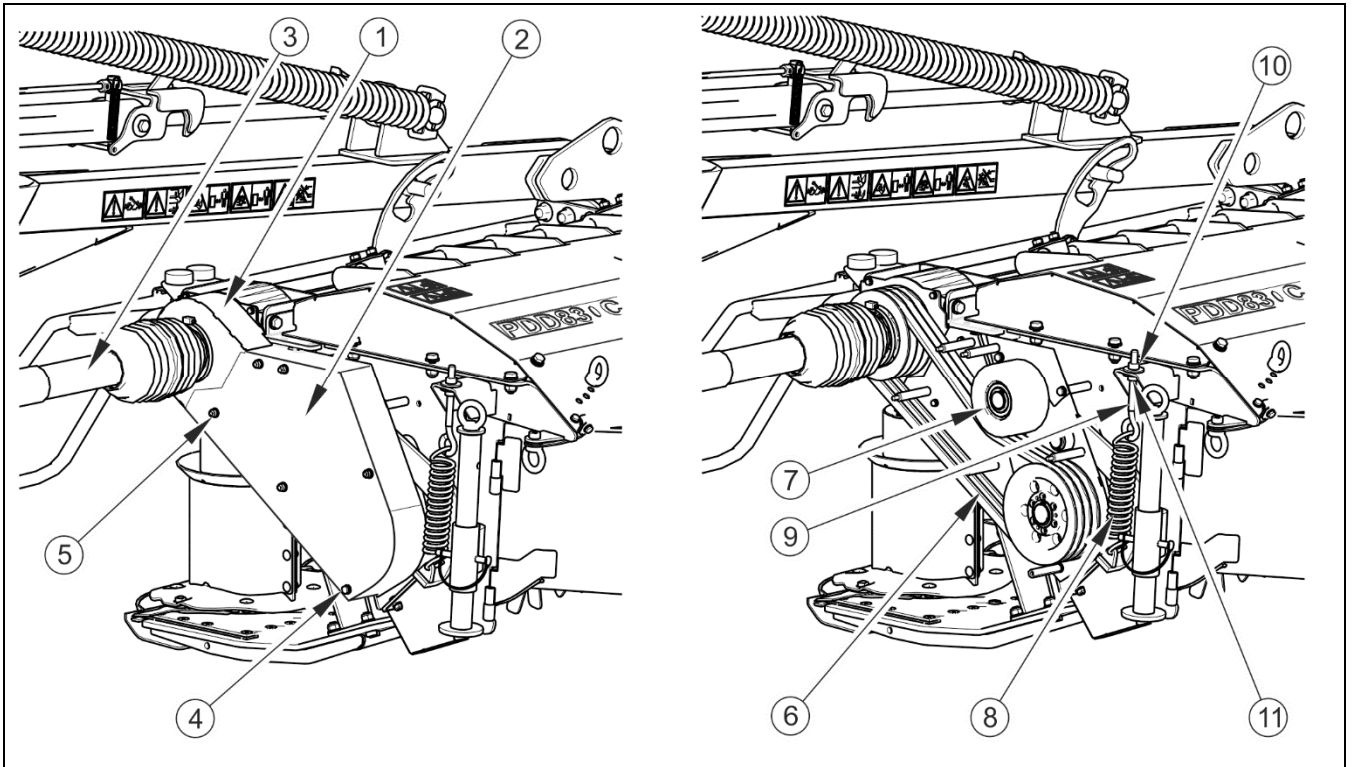

FIG. 5.4 Belt drive tension adjustment

(1) transmission guard, (2) front guard, (3) PTO shaft, (4) bolt, (5) nuts, (6) transmission belt, (7) tensioner, (8) tension spring, (9) tensioner bolt, (10) adjustment nut; (11) locknut

5.4 CUTTERBAR MAINTENANCE

Cutter bar maintenance involves general inspection of cutter bar condition and also oil changing, or replenishing transmission oil deficiency. In the event of damage to cutter bar contact authorised service point in order perform repairs.



Check oil level daily during the season at filler plug opening (1)

For daily oil inspection of cutterbar, lower and set cutterbar level. Check oil at filler plug opening (1), which is on the top of the cutterbar between discs 3 and 4 looking from the side of the cutterbar drive transmission. Oil level should be 6 ÷ 8 mm above the bottom of the cutterbar. When inspecting the level of hot oil wait for 3 minutes and check the level again. When checking cold oil wait for 15 minutes and check again. First oil change should be made after 50 hours work and then, after each 500 hours work or at least once in the season.

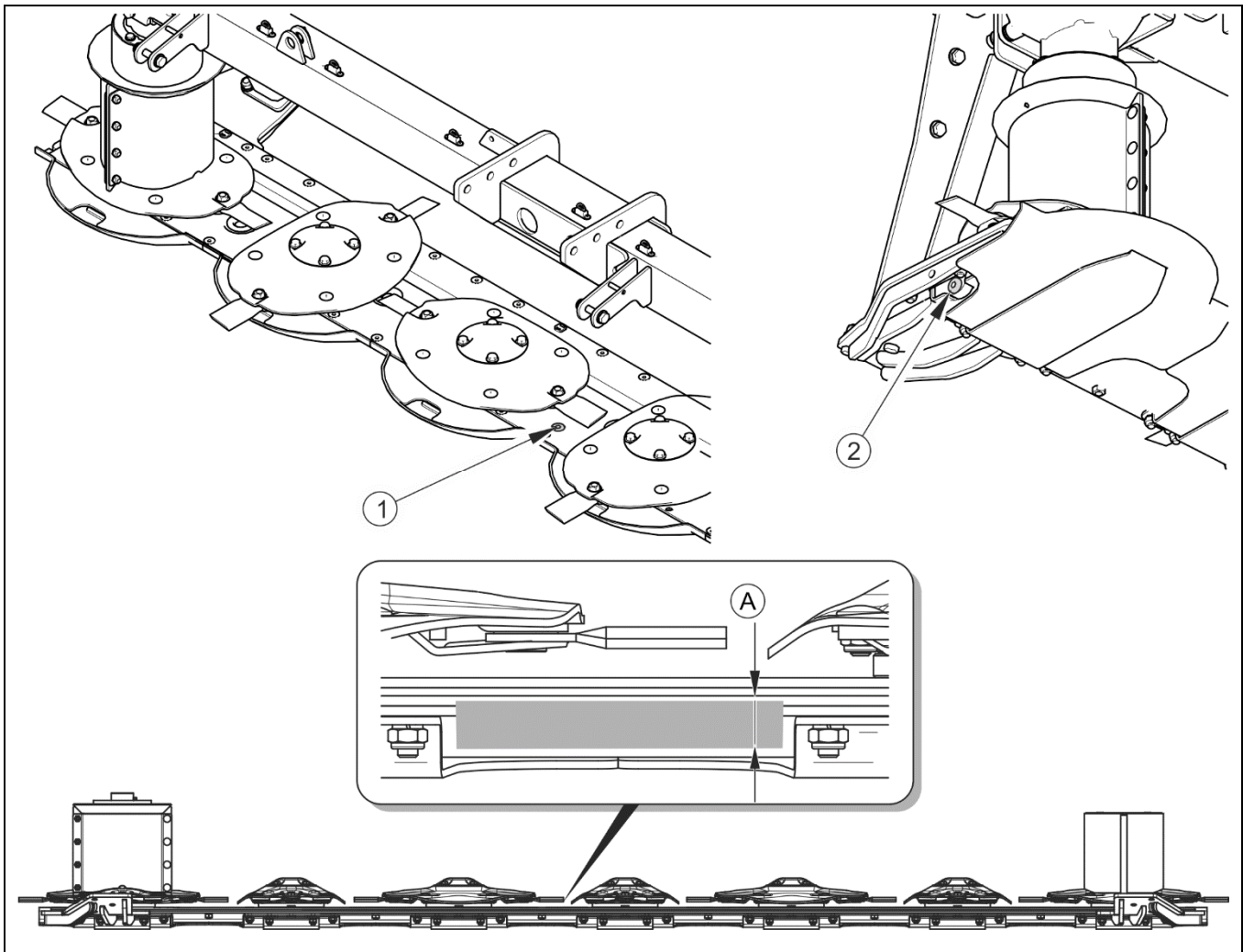

FIG. 5.5 Inspection and oil change points on cutterbar

(1) inlet cap; (2) drain plug; (A) correct oil level 6 ÷ 8 mm from the cutter bar bottom

Oil change should be conducted at working temperature, if the machine has worked for several minutes, then possible contamination, in the cutterbar is mixed with the oil and then is drained out with it.

In order to change oil:

- ➔ unscrew filler plug (1),
- ➔ raise cutterbar,
- ➔ unscrew drain plug (2) enabling old oil to drain out and be collected in appropriate container,
- ➔ clean plug of any contamination and tighten,
- ➔ lower cutterbar to horizontal position,

- ➔ pour in required oil quantity and tighten filler plug (1).



Oil in cutter bar must be changed after the first 50 hours of work. The next oil change should be made after 500 hours of work or once a year, whichever occurs first.

The correct amount of oil for one cutterbar of lateral mower is 3 litre. Only use transmission oil SAE 90EP (80W90 GL-5).

If a leak is noticed, carefully inspect seals and check oil level. Mower operation with low oil level may cause lasting damage.



ATTENTION

Never pour in less or more oil than is recommended. Incorrect oil quantity leads to overheating of cutterbar and then to bearings damage.

Only use oil recommended by the Manufacturer.

To ensure proper operation of the mower, regularly clean and lubricate drive disc articulated shaft (2) - figure (5.6). Failure to regularly clean and lubricate the articulated shaft can lead to seizing of the connection and machine damage.



ATTENTION

The dirt accumulated inside the drive disc such as grass clippings, sand, etc. can lead to seizure of the articulated shaft. Shaft seizure can damage the mower transmission.



Carry out maintenance of the drive disc at least twice during the grass mowing season and always after the season.

Required service actions:

- ➔ unscrew M8 self-locking nuts (5) and take out M8x25 bolts (4),
- ➔ Remove both covers (3),
- ➔ Clean and lubricate the articulated shaft (2),
- ➔ Clean the inner surfaces of the cover,
- ➔ replace the covers and insert the bolts. The secure the connection with washers (6) and nuts (5).

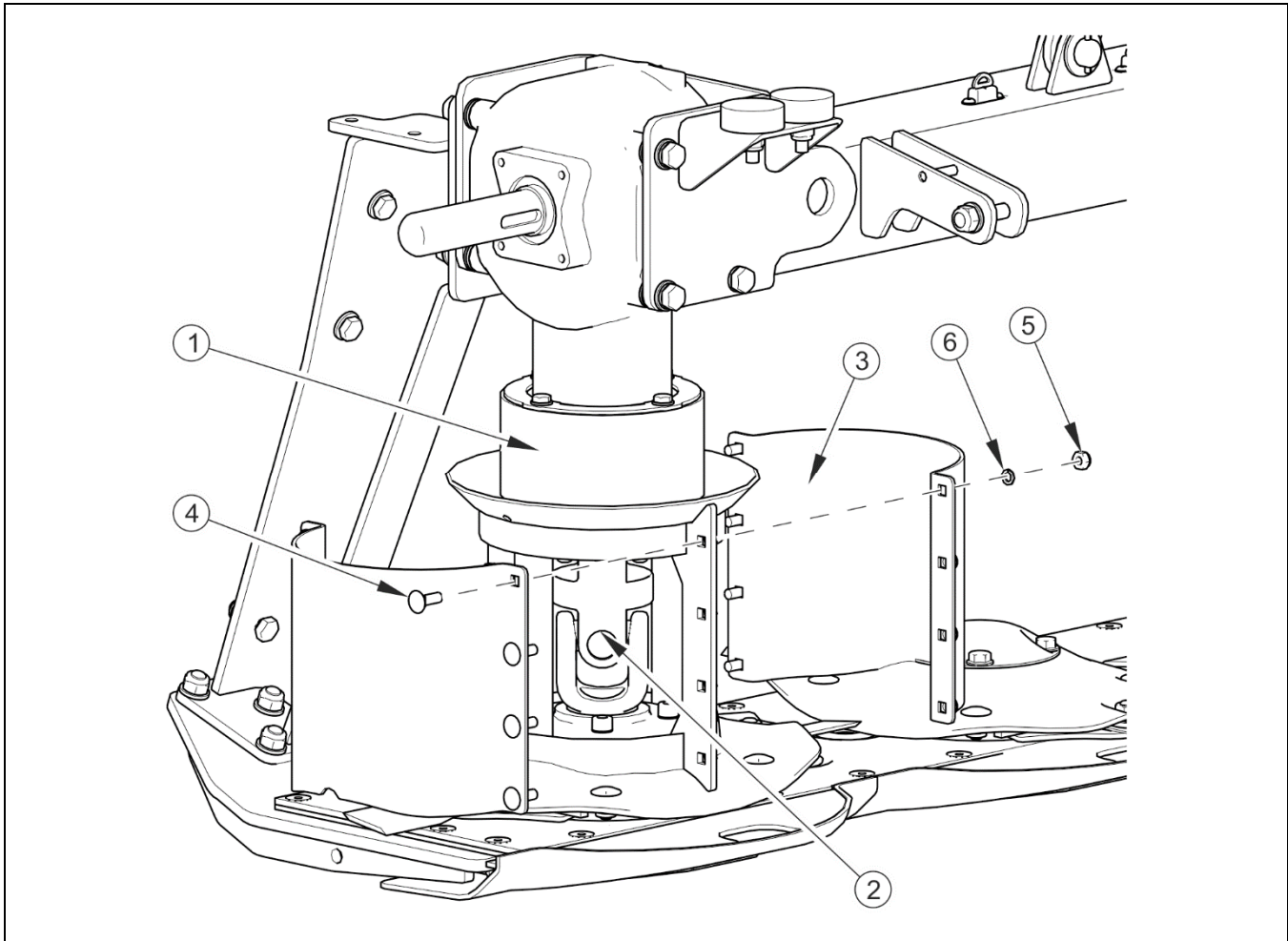

FIG. 5.6 Clean and lubricate the drive disk

(1) transmission guard, (2) articulated connector, (3) guard, (4) M8x25 bolt, (5) M8 self-locking nut, (6) spring washer

5.5 HYDRAULIC SYSTEM OPERATION

Always adhere to the principle that the oil in the mower hydraulic system and in the tractor hydraulic system are of the same type. Application of different types of oil is not permitted. In new mowers, the hydraulic system is filled with hydraulic oil AGROL U to a quantity of 6 l.



DANGER

Before commencing whatever work on hydraulic system reduce the pressure in the system. During work on hydraulic systems use the appropriate personal protection equipment i.e. protective clothing, footwear, gloves eye protection. Avoid contact of skin with oil.

The mower's hydraulic system should be completely tight sealed. Checking tightness of hydraulic system involves connecting machine with tractor and starting hydraulic cylinder

rams and holding them in position of maximum extension for a period of 30 seconds. In the event of confirmation of an oil leak on hydraulic line connections, tighten connections, and if this does not remedy faults then change line or connection elements. If oil leak occurs beyond connection, the leaking line system should be changed. Change of sub-assemblies is equally required in each instance of mechanical damage. In the event of confirmation of damage of a hydraulic ram cylinder it must be replaced or repaired. In such an event the whole set of seals must be changed.



Flexible hydraulic conduits should be replaced after 4 years of use.

Because of its composition the oil applied is not classified as a dangerous substance, however long-term action on the skin or eyes may cause irritation. In the event of contact of oil with skin wash the place of contact with water and soap. Do NOT apply organic solvents (petrol, kerosene). Contaminated clothing should be changed to prevent access of oil to skin. In the event of contact of oil with eye, rinse with large quantity of water and in the event of the occurrence of irritation consult a doctor. Hydraulic oil in normal conditions is not harmful to the respiratory tract. A hazard only occurs when oil is strongly atomised (oil vapour), or in the case of fire during which toxic compounds may be released. Oil fires should be quenched with the use of carbon dioxide, foam or extinguisher steam.

TAB. 5.2 Characteristics of Agrol U oil

tem	Name	Unit	VALUE
1	Kinematic viscosity at 100°C	-	10.0- 11.5
2	Viscosity index, min.		>95
3	Pour point, max.	°C	<-24
4	Base number mgKOH/g	-	9.9
5	Flash-point	°C	>230

In the event of necessity of changing hydraulic oil for another oil, check the recommendations of the oil Manufacturer very carefully. If it is recommended to flush the system with the appropriate preparation, then comply with these recommendations. Attention should be given, so that chemical substances used for this purpose do not damage the materials of the hydraulic system.

ATTENTION



Mower with a leaking hydraulic system must NOT be used.
 The condition of hydraulic systems should be inspected regularly while using mower.
 The hydraulic system is under high pressure when operating.
 Regularly check the technical condition of the connections and the hydraulic conduits.
 Use the hydraulic oil recommended by the Manufacturer. Never mix two types of oil.

5.6 LUBRICATION

Mower lubrication must be carried out in places indicated in figures (5.7) & (5.8), and also detailed in table (5.3). This procedure should be performed using a hand or foot operated grease gun filled with generally available permanent grease. Before lubricating, insofar as is possible remove old grease and other contamination. Remove excess oil or grease

Oil gear in cutter bar in accordance with recommendations given in section 5.4 CUTTER BAR MAINTENANCE. For detailed instructions on how to change oil in intersecting axis gears please refer to section 5.3 DRIVE SYSTEM MAINTENANCE.



When using the mower the user is obliged to observe lubrication instructions according to attached schedule. Excess lubrication substance causes depositing additional contaminants in places requiring lubrication, therefore it is essential to keep individual machine elements clean.

TAB. 5.3 Lubrication points

ITEM	NAME	NUMBER OF LUBRICATION POINTS	TYPE OF GREASE	LUBRICATION FREQUENCY
1	Lifting pin of lifting arm	2	A	20 hours
2	Tipping pin of lifting arm	2	A	20 hours
3	Cutting unit pin	2	A	20 hours
4	Swath guide axis shaft (PDD830)	4	A	50 hours
5	Tilting arm cylinder ram eye	2	A	50 hours

ITEM	NAME	NUMBER OF LUBRICATION POINTS	TYPE OF GREASE	LUBRICATION FREQUENCY
6	Tilting arm cylinder ram eye	2	A	50 hours
7	Lifting arm cylinder ram eye	2	A	50 hours
8	Lifting arm cylinder eye	2	A	50 hours
9	Multi-splined drive shaft	1	A	20 hours
10	Central transmission	1	B	500 hours
11	Lateral intersecting axis gear	2	B	500 hours
12	Cutter bar	2	B	500 hours
13	Cutterbar double articulated connection joint	6	A	50 hours
14	PTO shafts★	★	★	★
15	Swath conditioner shaft bearings (PDD830C)		A	50 hours

Marking description in Item column in table 5.3 conforms with numbering shown in figures (5.7) and (5.8).

★For detailed information on maintenance please refer to maintenance instructions attached to the shaft.

TAB. 5.4 Recommended lubricants

LISTED ON TAB. 5.3	DESCRIPTION
A	Machine general-purpose grease (lithium, alkaline),
B	SAE 90EP (80W90 GL-5) transmission oil .

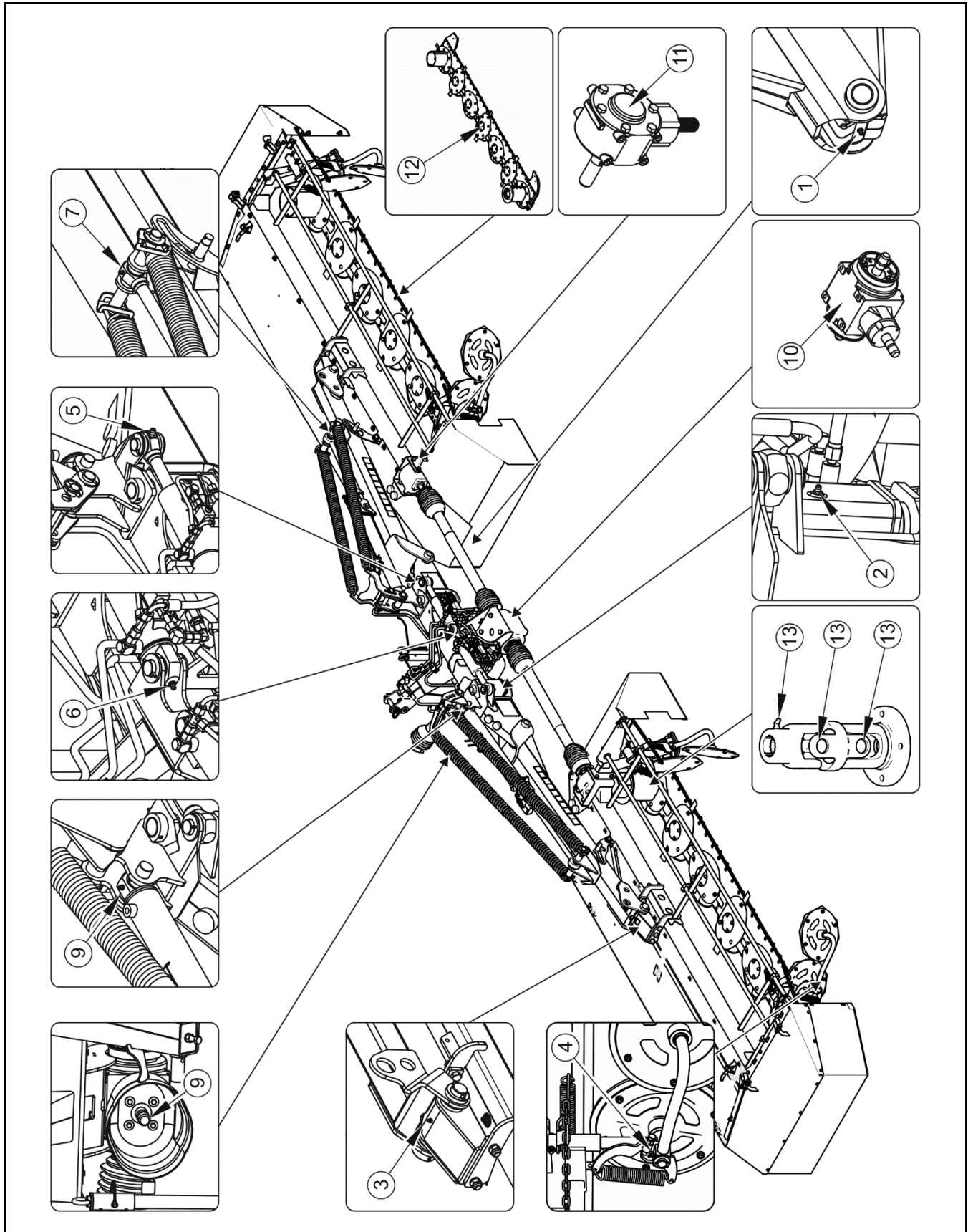

FIG. 5.7 Lubricating points of the PDD830 / PDD830C mower

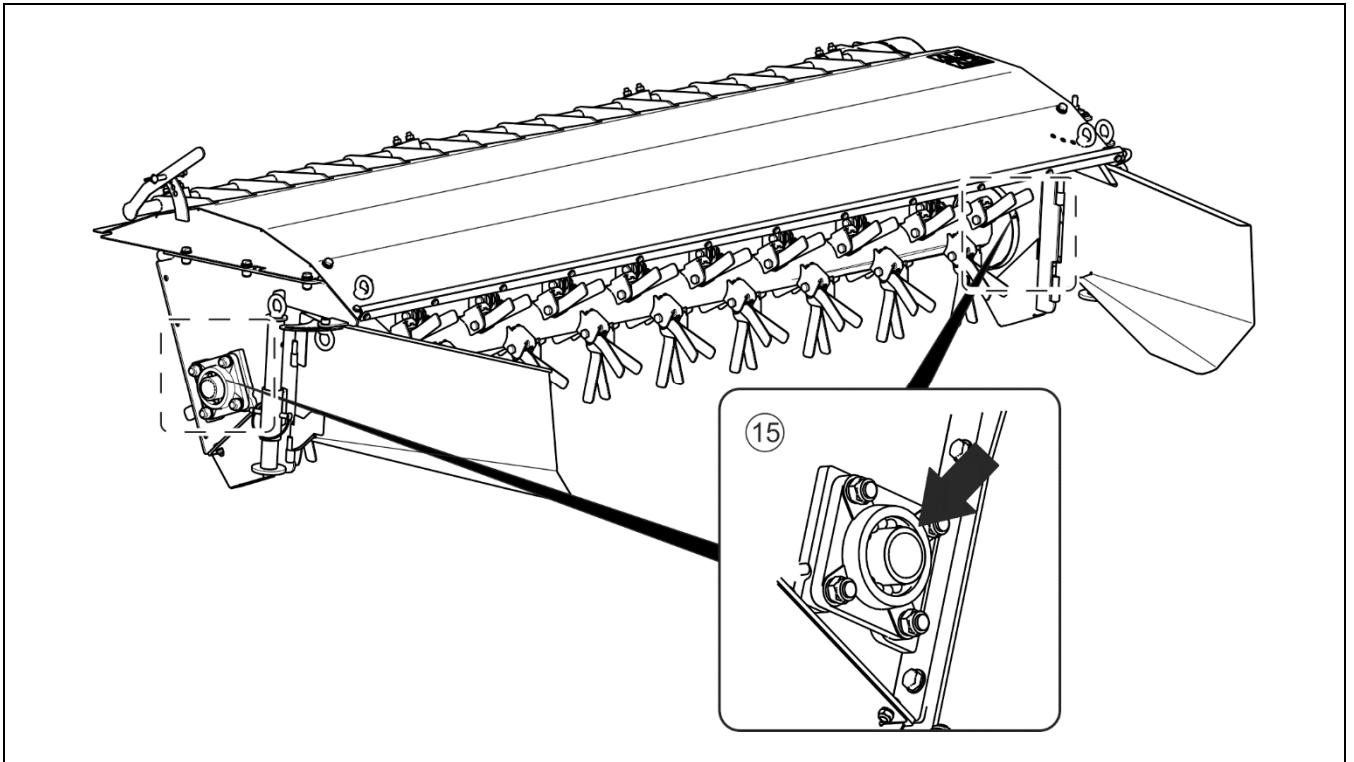

FIG. 5.8 Lubrication points on the PDD830C mower

5.7 STORAGE

After finishing work with disc mower carefully clean and wash it with water jet. While washing do not direct a strong water or steam jet at information and warning decals or bearings. Nozzle of pressure or steam washer should be kept at a distance of not less than 30 cm from cleaned surface.

After cleaning mower inspect the whole machine, inspect technical condition of individual elements. Used or damaged elements should be repaired or replaced.

In the event of damage to the paint coat, clean rust and dust from damaged area, degrease and then paint with undercoat and after it is dry paint with surface coat paint retaining colour uniformity and even thickness of protective coating. Until the time of touch-up painting, the damaged place may be covered with a thin layer of grease or anticorrosion preparation. Mower should be kept in closed or roofed building at temperature above 0°C.

If the mower shall not be used for a long period of time, protect it against adverse weather conditions, especially those which may cause rusting of steel. Lubricate mower according to the instructions provided. In the event of prolonged work stoppage, it is essential to lubricate

all elements regardless of the period of the last lubrication process. Additionally before the winter period apply grease to hitching system pins.

5.8 TIGHTENING TORQUE FOR NUT AND BOLT CONNECTIONS

Unless other tightening parameters are given, during maintenance repair work apply appropriate torque to tightening nut and bolt connections. Recommended tightening torque of most frequently applied nut and bolt connections are given in table (5.5). Given values apply to non-lubricated steel bolts.

Detailed inspection of tightness of nut and bolt connections should be made after the first 10 hours of work, and then each time at the end of working year of mower.

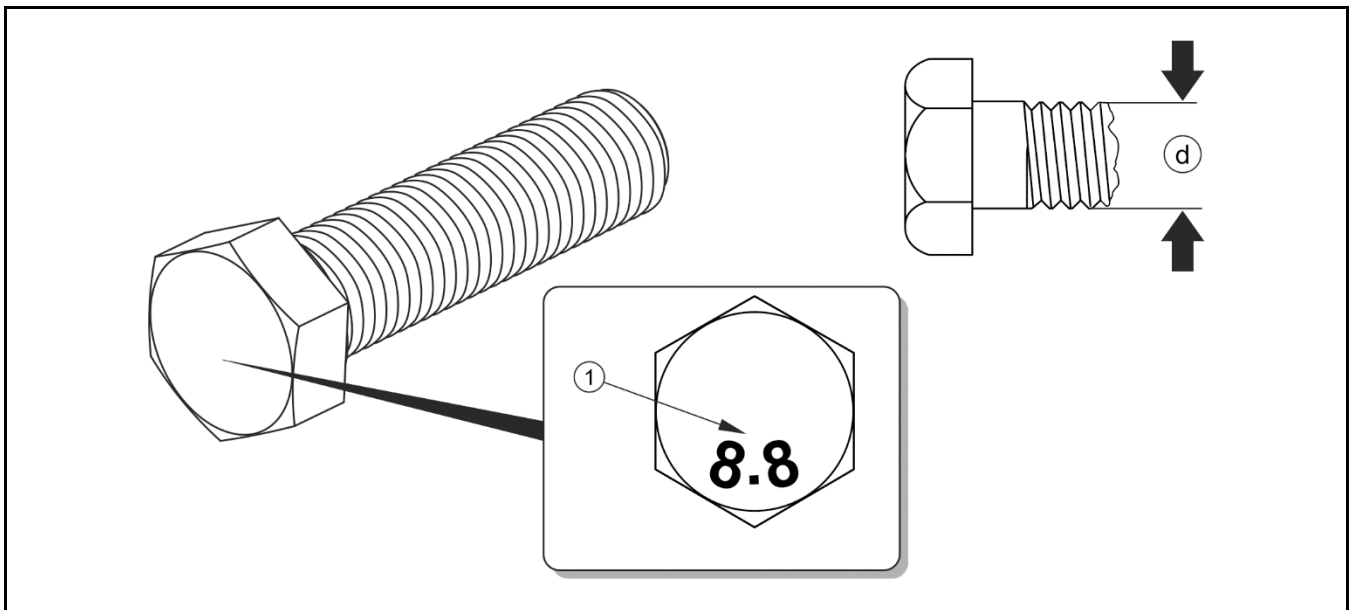

FIG. 5.9 Bolt with metric thread

(1) bolt strength class, (d) thread diameter

TAB. 5.5 Tightening torque for nut and bolt connections

THREAD (D) [MM]	5.8	8.8	10.9
	M_D [NM]		
M6	8	10	15
M8	18	25	36
M10	37	49	72
M12	64	85	125
M14	100	135	200
M16	160	210	310
M20	300	425	610
M24	530	730	1 050
M27	820	1 150	1 650
M30	1050	1 450	2 100

(M_D) – tightening torque, (d) thread diameter

5.9 TROUBLESHOOTING

TAB. 5.6 Faults and means of remedying them

TYPE OF FAULT	CAUSE	REMEDY
Mower arm cannot be lifted or lowered using the hydraulic cylinder	Blocked cylinder lock	To unblock lock pull cable
	Incorrectly connected or damaged quick coupler	Check quick couplers and manner of their connection
	The tractor's hydraulic system is out of order	Check condition of tractor hydraulic system
Stubble is uneven	Cutter bar is excessively load relieved	Set load relief spring appropriately
	Tractor PTO rotation speed too low	Maintain correct, constant PTO speed

TYPE OF FAULT	CAUSE	REMEDY
	Worn cutting blades	Turn blades onto the second side or replace
	Incorrect cutting angle	Set appropriate cutterbar inclination by adjustment of top link
Excessive vibration during work	Damaged or missing flail blade	Check flail blades, if necessary replace
	Damaged PTO shaft	Check shafts, if necessary replace
	Damaged cutterbar bearing	Repair at an authorised service point
Excessive heating of intersecting axis gear or cutterbar	Incorrect oil level	Check oil level.
	Damaged bearing	Repair at an authorised service point
Hydraulic safety device does not work	Cylinder valve closed	Set cylinder interlock valve lever in open position
Mower drive stops during cutting	Shaft overload clutch activated as a result of cutting discs being blocked	Disconnect power from mower; remove collected grass or foreign body from cutting unit
	Damaged cog in cutterbar	Repair at an authorised service point
	Damaged intersecting axis gear	Repair at an authorised service point

NOTES

A series of horizontal dotted lines for writing notes.

