



PRONAR SP. Z O.O.

17-210 NAREW, UL. MICKIEWICZA 101A, WOJ. PODLASKIE

PHONE: +48 085 681 63 29

+48 085 681 64 29

+48 085 681 63 81

+48 085 681 63 82

FAX: +48 085 681 63 83

+48 085 682 71 10

www.pronar.pl

OPERATOR'S MANUAL

SPREADER

PRONAR HPT70

TRANSLATION OF THE ORIGINAL COPY OF THE MANUAL

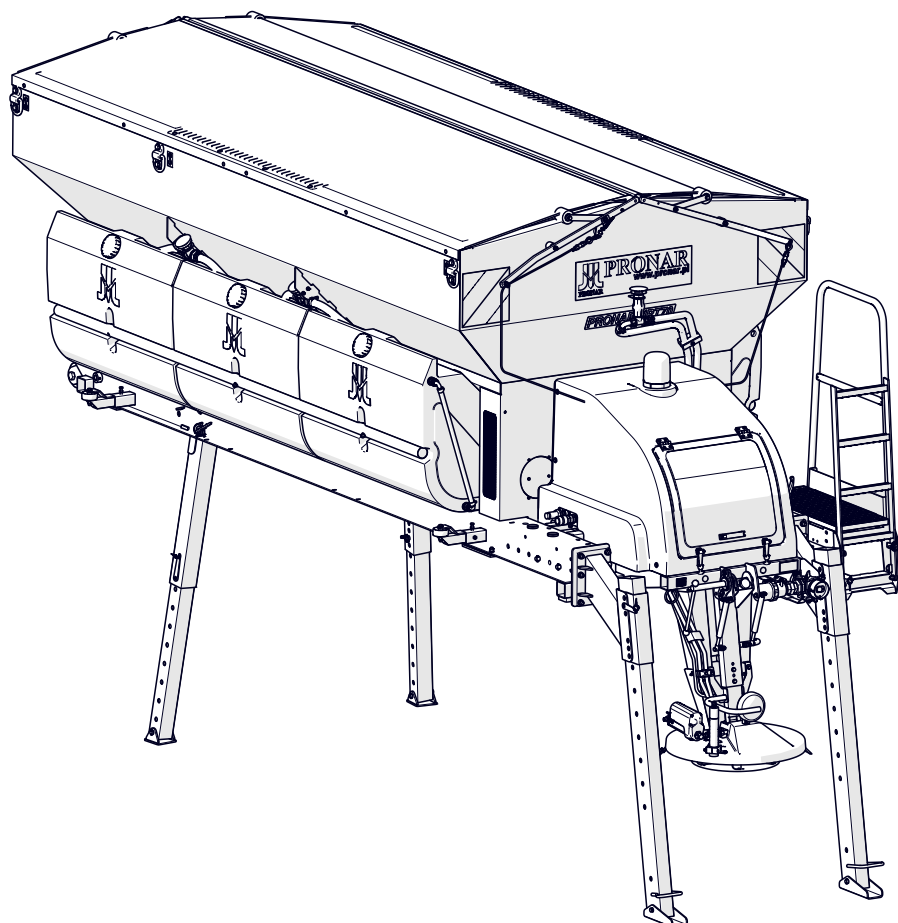

REVISION 1A

02-2020

PUBLICATION NO.: 470.01.UM



TABLE OF CONTENTS

INTRODUCTION

Introduction	2
Symbols appearing in this Operator's Manual	3
Directions used in this Operator's Manual	4
Environmental hazards	5
Inspection	6

BASIC INFORMATION

1.1	Identification	1.2
1.2	Intended use	1.3
1.3	Equipment	1.5
1.4	Terms & Conditions of Warranty	1.6
1.5	Shipping	1.7
1.6	Withdrawal from use	1.10

SAFETY ADVICE

2.1	Basic safety rules	2.2
2.2	Safety when hitching the machine	2.3
2.3	Safety rules when working with hydraulic system	2.4
2.4	Safety during maintenance work	2.5
2.5	Safety during machine operation	2.7
2.6	Residual risk	2.8
2.7	Information and warning decals	2.9

DESIGN AND OPERATION

3.1	Technical specification	3.2
3.2	General design	3.3
3.3	Hydraulic system	3.4
3.4	Brine spray system	3.5
3.5	Hopper and spreading system	3.6
3.6	Electrical system	3.7

CONTROL PANEL

4.1	Control panel	4.2
4.2	Control panel menu	4.3

CORRECT USE

5.1	Get ready for operation before first use	5.2
5.2	Inspections during daily operation	5.3
5.3	Machine setup	5.4
5.4	Get ready for operation	5.12
5.5	Load the machine	5.15
5.6	Machine operation	5.19
5.7	driving on public roads	5.25
5.8	Unloading	5.26
5.9	Remove the machine from the carrier vehicle	5.29

PERIODIC INSPECTIONS

MAINTENANCE

6.1	Periodic maintenance schedule	6.2
6.2	Inspect rollers and conveyor belt	6.4
6.3	Adjust rollers and conveyor belt	6.5
6.4	Inspect and replace of conveyor belt brushes	6.7
6.5	Inspect spreading disc	6.8
6.6	Inspection of hydraulic system	6.9
6.7	Check technical condition of electrical system	6.10
6.8	Inspection of tightening torque of nut and bolt connections	6.12
6.9	Clean brine filter	6.13
6.10	Replacement of oil filter	6.14
6.11	Checking oil level and change oil in conveyor drive transmission	6.15
6.12	Replace hydraulic lines	6.16
6.13	Post-season inspection	6.17
6.14	Machine cleaning	6.18
6.15	Storage	6.20
6.16	Troubleshooting	6.21
6.17	Consumables	6.23

LUBRICATION SCHEDULE

7.1	Lubrication	7.2
7.2	Lubrication schedule	7.3



PRONAR Sp. z o.o.

ul. Mickiewicza 101 A

17-210 Narew, Polska

tel./fax (+48 85) 681 63 29, 681 63 81, 681 63 82,
681 63 84, 681 64 29

fax (+48 85) 681 63 83

http://www.pronar.pl

e-mail: pronar@pronar.pl

EC DECLARATION OF CONFORMITY OF THE MACHINERY

PRONAR Sp. z o.o. declares with full responsibility, that the machine:

Description and identification of the machinery	
Generic denomination and function:	Spreader
Type:	HPT70
Model:	—
Serial number:	
Commercial name:	Spreader PRONAR HPT70

to which this declaration relates, fulfills all the relevant provisions of the Directive **2006/42/EC** of The European Parliament and of The Council of 17 May 2006 on machinery, and amending Directive 95/16/EC (Official Journal of the EU, L 157/24 of 09.06.2006).

The person authorized to compile the technical file is the Head of Research and Development Department at PRONAR Sp. z o.o., 17-210 Narew, ul. Mickiewicza 101A, Poland.

This declaration relates exclusively to the machinery in the state in which it was placed on the market, and excludes components which are added and/or operations carried out subsequently by the final user.

Narew, the 2020-01-24

Place and date

PRONAR Spółka z o.o.
17-210 Narew ul. Mickiewicza 101A
Tel. (85) 681 63 29, 682 72 54
Fax: (85) 681 63 83
NIP 543-02-00-939, KRS 0000139188
BDO 000014169

**Z-CA DYREKTORA
d/s technicznych
członek zarządu**

Roman Ormelianuk

*Full name of the empowered person
position, signature*

INTRODUCTION

INTRODUCTION

Information contained herein is current at date of publication. As a result of improvements, some numerical values, illustrations and assemblies (standard, additional and optional equipment) referred to in this publication may not correspond to the actual specification of the machine delivered to the user.

The figures shown in this publication are intended to explain the principle of operation of the machine and may differ from the actual specification. The above cannot be a reason for any claims.

The manufacturer reserves the right to introduce design changes in machines produced that facilitate and improve the quality of machine operation, without making minor amendments to this Operator's Manual.

This Operator's Manual is an integral part of the machine documentation. Before using the machine, the user must carefully read this Operator's Manual and observe all recommendations. This guarantees safe operation and ensures failure-free work of the machine. The machine is designed to meet obligatory standards, documents and legal regulations currently in force.

If the information contained in the Operator's Manual needs clarification then the user should refer for assistance to the sale point where the machine was purchased or to the Manufacturer.

It is recommended that the serial numbers of the machine and major subassemblies are inscribed in the spaces below after purchase of the machine.

U.01.2.EN

Machine serial number

--	--	--	--	--	--

This Operator's Manual contains important safety and operating instructions for the machine. The Operator's Manual should be kept near the machine so that it is accessible to authorized operators.

Keep this manual for future reference. If the Operator's Manual is lost or damaged, contact the seller or the manufacturer for a copy.

The Operator's Manual is intended for the end user. For this reason, some required maintenance activities are listed in the inspection tables but the procedure is not described in this Operator's Manual. To perform these activities, call the manufacturer's authorized service centre.

SYMBOLS APPEARING IN THIS OPERATOR'S MANUAL

DANGER

Information, descriptions of danger and precautions as well as recommendations and prohibitions associated with the safety of use are marked in the text with the sign **DANGER**. Failure to observe the instructions may endanger the machine operator's or other person's health or life.



ATTENTION

Vital information and instructions that must be observed are highlighted by a broder and accompanied by the text: **IMPORTANT**. Failure to observe the instructions may lead to damage to the machine as a result of improper operation, adjustment or use.

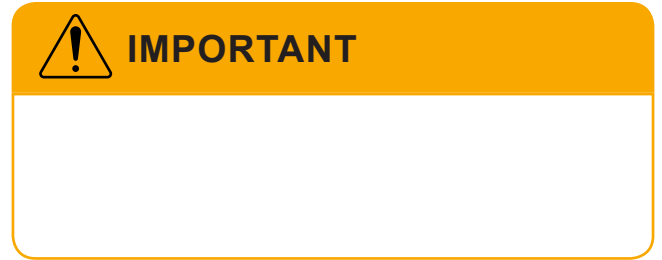

TIP

Additional tips included in the Operator's Manual describe useful advice for the machine operation and are marked with the sign **TIP**.



U.02.1.EN

DIRECTIONS USED IN THIS OPERATOR'S MANUAL

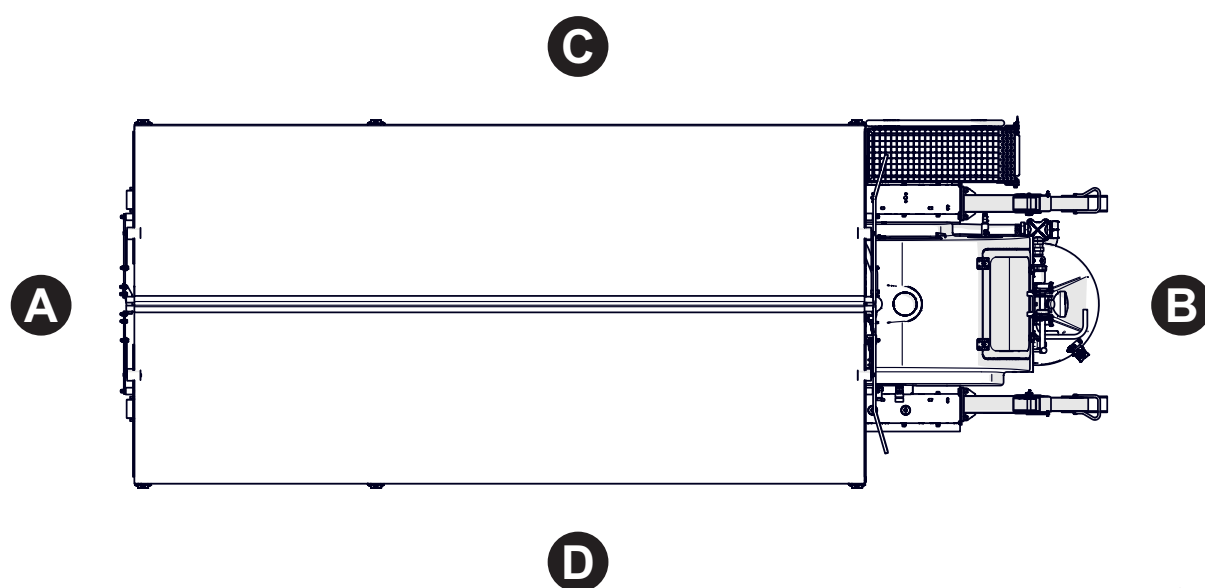

470-U.01-1

Figure 1 Directions used with reference to the machine
 (A) front (B) rear (C) right side (D) left side

Left side – side to the left hand of the operator facing in the direction of machine's forward travel.

Right side – side to the right hand of the operator facing in the direction of machine's forward travel.

Rotation to the right – clockwise rotation of a mechanism (the operator is facing the mechanism).

Rotation to the left – counterclockwise rotation of a mechanism (the operator is facing the mechanism).

U.03.2.EN INSPECTION OF THE MACHINE AFTER DELIVERY

The manufacturer guarantees that the machine is fully operational and has been checked according to quality control procedures and is ready for use. This does not release the *user* from an obligation to check the machine's condition after delivery and before first use. The machine is delivered to the *user* completely assembled. After delivery of the machine, the *user* is obliged to check completeness of the machine according to order.

INSPECTION RECOMMENDATIONS

- Check completeness of the machine according to order.
- Check technical condition of protective shields

and confirm that they open and close correctly,

- Check condition of paint coating; check the machine for traces of corrosion.
- Check the machine for damage resulting from wrong transport of the machine to its destination (crushing, piercing, bending or breaking of parts etc.).
- Check technical condition of conveyor belt.

Discovered defects should be notified directly to the seller in order to remove them. Incorrect level of operating fluids may indicate that there is a leakage. Check the machine for tightness.

U.26.2.PL

ENVIRONMENTAL HAZARDS

A hydraulic or gear oil leak constitutes a direct threat to the natural environment owing to its limited biodegradability.

Maintenance and repair work which involves the risk of an oil leak should be performed in the rooms with oil resistant surface. In the event of oil leaking into the environment, first of all contain the source of the leak, and then collect the leaked oil using available means. Remaining oil should be collected using sorbents, or by mixing the oil with sand, sawdust or other absorbent

materials. The oil contaminations, once gathered up, should be kept in a sealed, marked, hydrocarbon resistant container, and then passed on to the appropriate oil waste recycling centre. The container should be kept away from heat sources, flammable materials and food.

Oils, which have been used up or are unsuitable for further use owing to a loss of its properties should be stored in its original packaging in the conditions described above.

U.32.1.EN

INSPECTION

When using the machine, regular inspections of its technical condition and the performance of maintenance procedures are essential, which keep the machine in good technical condition. In connection with this, the user is obliged to perform all the maintenance and adjustment procedures defined by the Manufacturer, according to the specified schedule.

Repairs during the warranty period and all the inspections, except daily inspections may only be performed by authorised service points.

In the event of unauthorized repairs, changes to factory settings or activities which the machine operator is not allowed to perform, the warranty will be invalidated.

The complete inspection of the machine includes the following activities:

- periodic inspection of the machine performed according to the specified frequency and instructions included in section *Periodic inspections, maintenance*,
- lubrication according to section *Lubrication schedule*.



DANGER

Used oil or gathered remains mixed with absorbent material should be stored in a precisely marked container. Do not use food packaging for this purpose.

Inspections should be performed by an authorized service point every 250 engine working hours, i.e. after 250, 500, 750 working hours, etc. (during warranty period). Permissible delay in performing the inspection must not exceed the specified inspection frequency by



IMPORTANT

Waste oil should only be taken to the appropriate facility dealing with the re-use of this type of waste. The user **MUST NOT**: Do NOT pour oil into sewerage or water tanks.

more than 50 working hours. The scope of the inspections is detailed in the Operator's Manual.

U.41.1.EN

SECTION 1

BASIC INFORMATION

1.1 IDENTIFICATION

The spreader nameplate and serial number was placed on the back of the machine on the frame next to the attachment point of the left storage support - figure (1.1). When buying the machine check that the serial numbers on the machine agree with those given in the *WARRANTY BOOK*, in the sales documents and in the *OPERATOR'S MANUAL*.

The meaning of the individual entries found on the nameplate are presented in the table below - figure (1.1):

- A - machine name,
- B - machine type/symbol,
- C – serial number,
- D – year of manufacture,
- E – gross weight [kg],
- F – Quality Control stamp,
- G – machine name, name extension.

TIP

Demand that the seller carefully and precisely fills out the Warranty Book and guarantee repair coupons. A missing date of purchase or sale point stamp, may make the user ineligible for any warranty repair or refund.

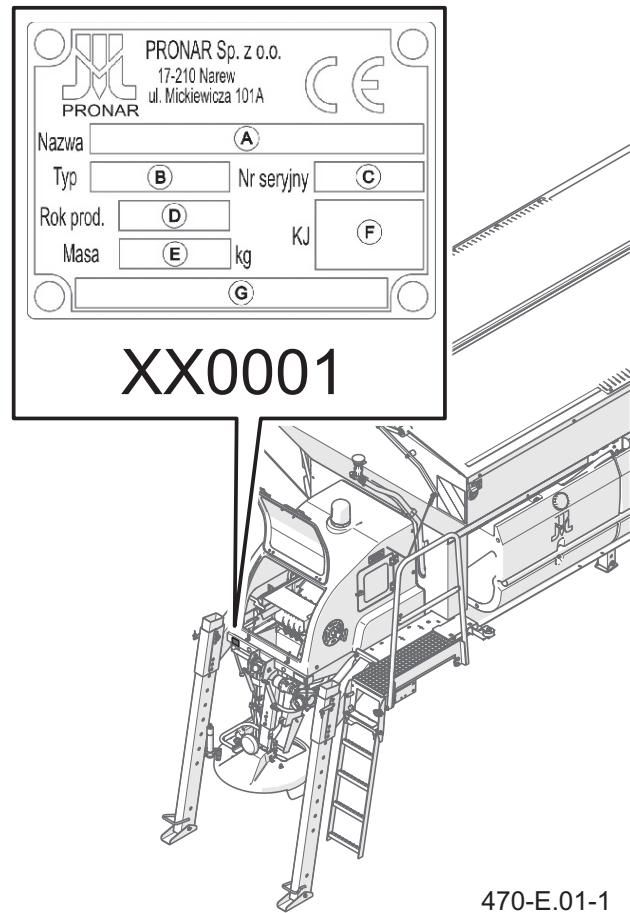

Figure 1.1 Location of the data plate.

E.2.4.470.01.1.EN

1.2 INTENDED USE

The PRONAR HPT70 spreader is used for surface spreading of coarse materials such as sand, aggregate and chemical agents (sodium chloride, calcium chloride, magnesium chloride, brine) for winter road maintenance. Using the machine for other purposes will be regarded as contrary to intended use. The spreader can be mounted on trucks that are equipped with a load box and that meet the requirements set out in Table 1.1.

Using it as intended also involves all actions connected with the safe and proper operation and maintenance of the machine. Due to the above, the user is obliged to:

- carefully read the *Operator's Manual* and the *Warranty Book* and follow the recommendations in these documents,
- understand the machine's operating principle and how to operate it safely and correctly,
- adhere to the established maintenance and adjustment plans,
- comply with general safety regulations while working,
- prevent accidents,
- comply with the road traffic regulations in force

in a given country, in which the machine is used.

The machine may only be used by persons, who:

- are familiar with the contents of the publications and documents delivered with the machine and with the contents of the carrier vehicle Operator's Manual,
- have been trained in the machine operation and work safety,
- have the required authorisation to drive the vehicle and are familiar with the road traffic regulations and transport regulations.

The spreader is designed according to current safety and engineering standards.



IMPORTANT

The machine must not be used for purposes other than those for which it is intended, in particular do NOT:

spread fertilisers or liquids

transport people, animals or any items on the machine

reload any items

If you spread materials other than those intended for this machine, you may risk:

problems in the spreading process, such as caking, clogging or spilling of the material

damage to machine component,

voiding the warranty.

Table 1.1. Carrier vehicle requirement

Contents	Unit	Requirements
Mounting method	–	on the carrier vehicle load platform by means of LC 2500N securing belts, according to EN 12195-2 standard
Minimum load box dimensions: ¹		
– length / width	mm	5,000 / 2,300
– height from the ground	mm	1,350 ÷ 1,700
Carrier vehicle load capacity	t	14/15.5/17 ²
Voltage of electrical system of control electronics	V	24
Hydraulic system		adapted for continuous operation
- minimum output	l/min	35
- minimum pressure	bar	160
- hydraulic couplers	-	HQ19-F-12G; HQ19-M-12G
Other requirements	–	connection with ground speed pulse input according to ISO 168442

¹⁾ for the distance between the spreading disc and the ground equal to 400 mm

²⁾ depending on the size of the sand spreader hopper installed

1.3 EQUIPMENT

The spreader equipment includes:

- Operator's Manual
- Warranty Book
- Supporting legs
- side bumpers (*when the spreader is mounted on a carrier vehicle with strong side boards*),

Additional (optional) equipment:

- automatic control (*automatic settings adjustment depending on selected working mode and*

temperature),

- software for collecting data from the meters and counters,
- filtration system (*additional oil pressure filter in the hydraulic supply circuit of the machine*).

Version:

- tank with a capacity of 7.8 m³ or 9 m³
- tank made of carbon or stainless steel,
- galvanised or painted frame,

E.2.4.470.03.1.EN

1.4 TERMS & CONDITIONS OF WARRANTY

PRONAR Sp. z o.o. Narew guarantees the reliable operation of the machine when it is used according to its intended purpose as described in the *Operator's Manual*. Defects discovered during the warranty period will be removed by the Warranty Service. The repair period is specified in the *Warranty Book*.

The warranty does not cover those parts and sub-assemblies of the machine which are subject to wear in normal usage conditions, regardless of the warranty period.

The warranty service only applies to such cases as: mechanical damage which is not the user's fault, factory defects of parts, etc.

In the event of damage arising from:

- mechanical damage which is the user's fault, damage caused by road accidents,
- inappropriate use, adjustment or maintenance, use of the machine for purposes other than those for which it is intended,

- use of damaged or malfunctioning machine,
- repairs carried out by unauthorised persons, repairs carried out improperly,
- making unauthorised alterations to machine design,

the user will lose the right to warranty service.

Modifications of the machine without the written consent of the Manufacturer are prohibited. In particular, do NOT weld, drill holes in, cut or heat the main structural elements of the machine which have a direct impact on the machine operation safety.

For detailed Terms & Conditions of Warranty, please refer to the *Warranty Book* attached to each machine.

TIP

Demand that the seller carefully and precisely fills out the Warranty Book and guarantee repair coupons. A missing date of purchase or sale point stamp, may make the user ineligible for any warranty repair or refund.

E.2.4.415.04.1.EN

1.5 SHIPPING

The machine is prepared for sale completely assembled and does not require packing. The machine operation and maintenance manual and control panel with a wiring harness are the only items that are packed. The machine is delivered to the user by transport vehicle, after being attached to the load box. The machine should be firmly secured by certified fastening belts fitted with a tightening mechanism.

When loading and unloading the machine, comply with the general principles of workplace health and safety for reloading work. Persons operating reloading equipment must have the qualifications required to

operate these machines.

The machine should be attached to lifting equipment in places specially designed for this purpose - figure

 **DANGER**

When being transported on a motor vehicle the machine must be mounted on the vehicle's platform in accordance with all the safety requirements and regulations. Use only certified and technically reliable securing measures. Carefully read the manufacturer's instructions for the securing measures. Incorrect use of securing measures may cause an accident.

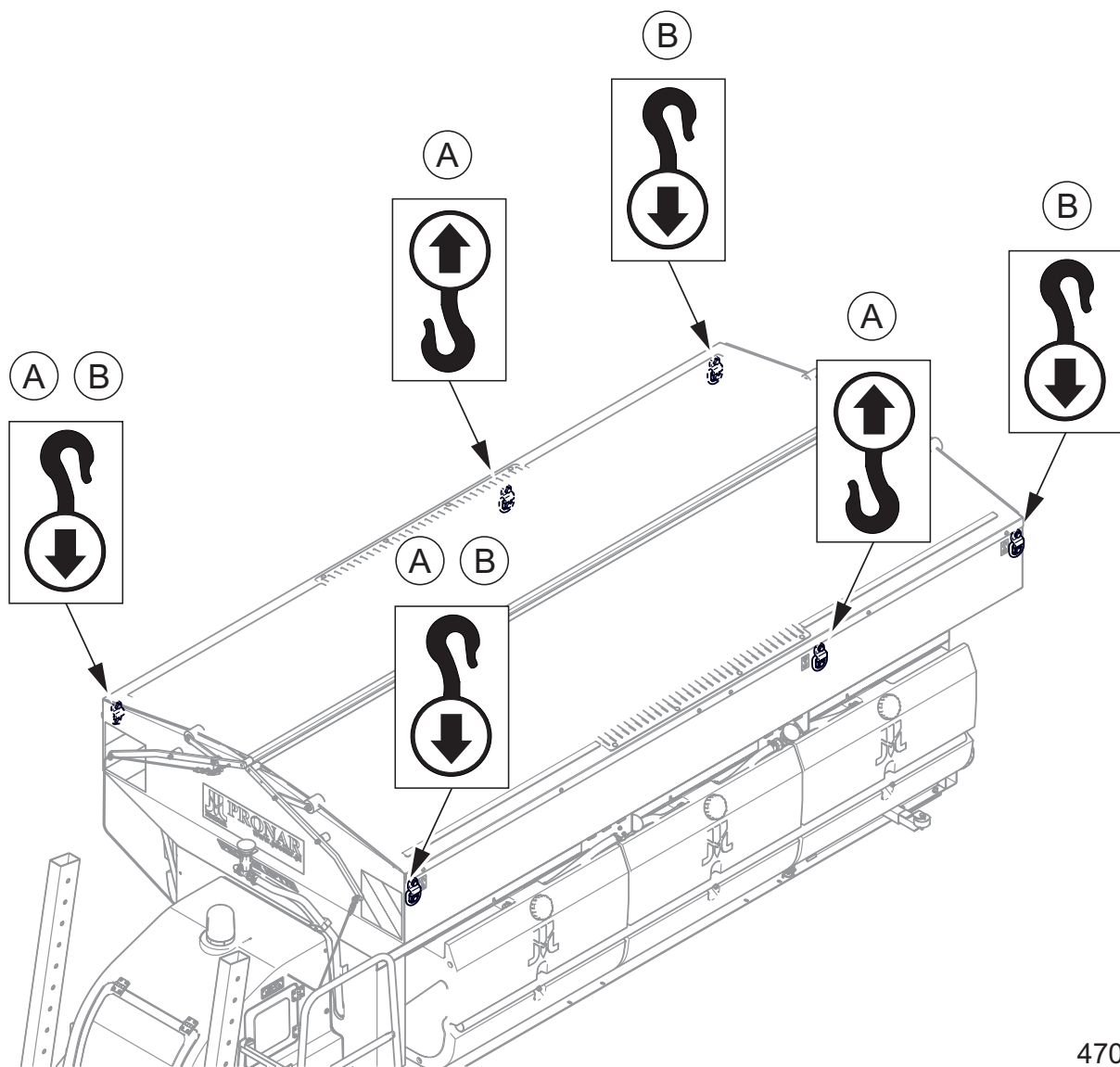

470-E.02-1

Figure 1.2 Transport lugs
A lifting equipment attachment points.

B attachment points to the carrier platform

(1.2), i.e. by the lugs on the frame sides (6 points). Due to location of the spreader's centre of gravity, lifting equipment should be attached to 4 points. Suspension points are identified with information decals. When lifting the machine take special care to avoid tipping over the machine and the risk of injuries from protruding parts. To keep lifted machine in the correct direction it is recommended to apply additional guy cables. During reloading work, particular care should be taken not to damage parts of the machine's fittings or the lacquer coating.



DANGER

When transporting the machine, the vehicle driver must exercise extreme caution. This is due to the vehicle's centre of gravity shifting upwards when the machine is loaded.



DANGER

Do not attach slings and any kind of cargo fasteners to elements other than those intended for this purpose (do NOT attach to hydraulic system and electrical system components). Persons must NOT be present in the manoeuvring zone during transferring the machine to another means of transport.



IMPORTANT

The machine must not be transported on support legs.

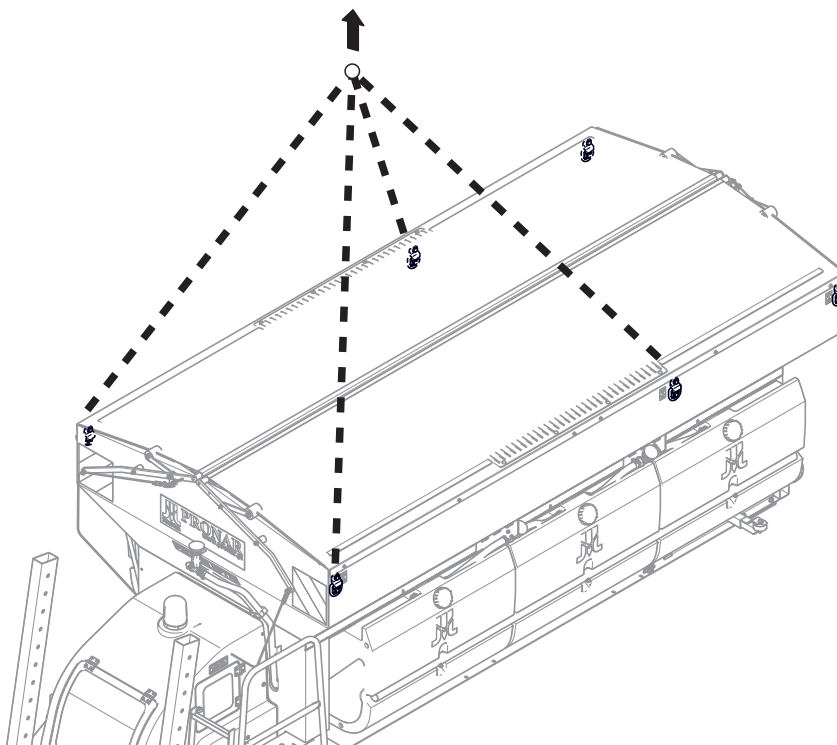

470-E.03-1

Figure 1.3 Lifting the machine by means of lifting equipment

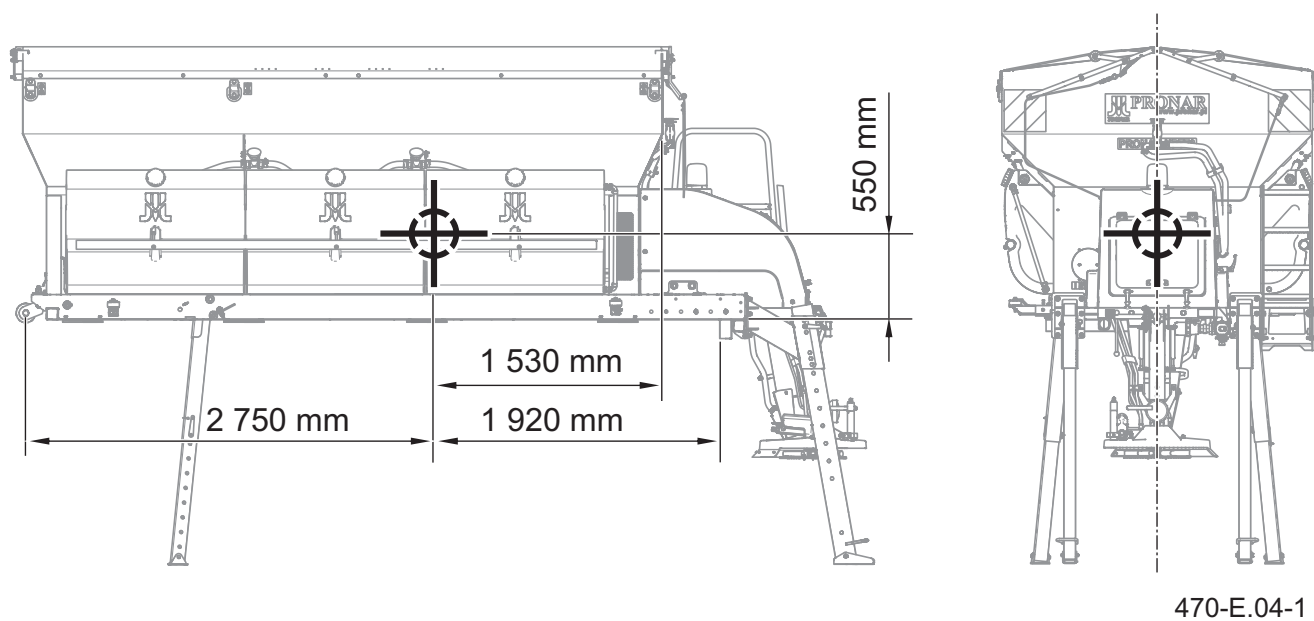

Figure 1.4 Location of the centre of gravity (9 m³ tank without load)



IMPORTANT

Depending on the machine setting, location of centre of gravity varies in the ± 100 mm range.

E.2.4.470.05.1.EN

1.6 WITHDRAWAL FROM USE

In the event of decision by the user to withdraw the machine from use, comply with the regulations in force in the given country concerning withdrawal from use and recycling of machines withdrawn from use.

Before proceeding to dismantle equipment, oil shall be completely removed from hydraulic system and transmission.

When spare parts are changed, worn out or damaged parts should be taken to a collection point for recyclable raw materials. Used oil and also rubber and plastic

elements should be taken to the appropriate facilities dealing with the recycling of this type of waste.



IMPORTANT

During dismantling, use the appropriate tools, equipment (overhead crane, crane or hoist etc.) and use personal protection equipment, i.e. protective clothing, footwear, gloves and eye protection etc.

Avoid contact of skin with oil. Do not allow used oil to spill.

E.2.4.470.06.1.EN

SECTION 2

SAFETY ADVICE

2.1 BASIC SAFETY RULES

- Before using the implement, the user must carefully read this Operator's Manual and the Warranty Book. When operating the machine, the operator must follow all instructions and recommendations in these documents.
- The user is obliged to be familiar with machine design, operation and safety features.
- The machine may only be used and operated by persons qualified to drive the carrier vehicle and trained in machine operation.
- If the information in this Operator's Manual is difficult to understand, contact the seller who runs the authorised technical service on behalf of the Manufacturer, or contact the Manufacturer directly.
- Careless and improper use and operation of the machine and also non-observance of the recommendations contained in this Operator's Manual endanger health and life third persons and/or machine operator.
- Be aware of the residual risk. Use caution when operating this machine and follow all relevant safety instructions.
- The machine must never be used by unauthorised persons, including children, and people under the influence of alcohol, drugs or other intoxicants.
- Non-compliance with the safety rules of this Operator's Manual can be dangerous to the health and life of the operator and others.
- The machine must not be used for purposes other than those for which it is intended. Anyone who uses the machine for purposes other than those for which it is intended takes full responsibility for any consequences of this potentially incorrect use. Use of the machine for purposes other than those for which it is intended by the Manufacturer may invalidate the guarantee.
- The machine may only be used when all the protective features (i.e. safety guards, bolts, cotter pins, warning decals) are technically sound and correctly positioned. In the event of loss or damage to the protective features, they must be replaced with new ones.
- The machine is not intended to transport any load (including people and animals) other than the bulk material to be spread.
- Observe all applicable legal regulations regarding environmental protection.
- When selling the machine, give the complete documentation together with the machine to the buyer.
- The machine carrier must be equipped with a first aid kit and a fire extinguisher.
- If you notice fire or smoke, stop the machine immediately. Call the fire brigade, locate the source of fire or smoke as soon as possible and start extinguishing the fire using fire-fighting equipment suitable for the burning material. Exercise extra caution.

F.2.4.415.01.1.EN

2.2 SAFETY WHEN HITCHING THE MACHINE

- The carrier vehicle to which the machine will be hitched must be technically reliable and must meet the relevant Manufacturer requirements.
- The machine should be secured to the carrier vehicle by means of suitable certified belts or chains.
- Be especially careful when hitching the machine to carrier vehicle.
- When hitching, there must be nobody between the machine and the carrier vehicle.
- After completed hitching of the machine, check the safeguards. Carefully read the carrier vehicle Operator's Manual.
- Be especially careful when unhitching the machine from the carrier vehicle.
- Machine dismounted from the carrier vehicle must be placed on parking stands, on level, sufficiently hard surface in such a manner as to ensure that it stable during storage and it can be mounted again.

F.2.4.415.02.1.EN

2.3 SAFETY RULES WHEN WORKING WITH HYDRAULIC SYSTEM

- The hydraulic system is under high pressure when operating.
- Regularly check the technical condition of the connections and the hydraulic conduits. There must be no oil leaks.
- In the event of the hydraulic system malfunction, discontinue using the machine until the malfunction is corrected.
- In the event of injuries being caused by pressurised hydraulic oil, contact a doctor immediately. Hydraulic oil may find its way under the skin and cause infections. In the event of contact of oil with eye, rinse with large quantity of water and in the event of the occurrence of irritation consult a doctor. In the event of contact of oil with skin wash the area of contact with water and soap. Do NOT apply organic solvents (petrol, kerosene).
- Use the hydraulic oil recommended by the Manufacturer. Never mix two types of oil.
- After changing the hydraulic oil, the used oil should be properly disposed of. Used oil or deteriorated oil should be stored in original containers or replacement containers resistant to hydrocarbons. Replacement containers must be clearly marked and appropriately stored.
- Do not store hydraulic oil in packaging designed for storing food or foodstuffs.
- Rubber hydraulic conduits must be replaced every 4 years regardless of their technical condition.
- Repair and replacement of hydraulic system elements should be entrusted to the appropriately qualified persons.

F.2.4.415.03.1.EN

2.4 SAFETY DURING MAINTENANCE WORK

- Do NOT carry out maintenance or repair work (except for the adjustment of the conveyor belt) with the machine drive engaged. When starting work, switch off the machine drive.
- The conveyor belt is adjusted with the conveyor drive turned on. Be especially careful when making the adjustment.
- During the warranty period, any repairs may only be carried out by warranty service authorised by the Manufacturer. It is recommended that necessary repairs to machine should be undertaken by specialised workshops.
- In the event of any fault or damage, do not use the machine until the fault has been corrected.
- During work use the proper, close-fitting protective clothing, gloves and appropriate tools. When working on hydraulic systems it is recommended to use oil resistant gloves and protective goggles.
- Any modification to the machine frees the manufacturer from any responsibility for damage or detriment to health which may arise as a result.
- The sand spreader can only be stood on when it is absolutely motionless and the carrier vehicle engine is switched off. Before climbing onto the sand spreader, immobilise the carrier vehicle with parking brake, secure against unauthorized access and remove key from ignition.
- Before undertaking any work on the machine, switch off the carrier vehicle engine and wait until all rotating parts of the machine come to a stop.
- Regularly check the technical condition of the safety devices and correct tightening of bolt connections.
- Regularly perform service inspections of machine as recommended by the Manufacturer.
- Before beginning repairs on hydraulic systems, reduce oil pressure.
- Servicing and repair work should be carried out in line with the general principles of workplace health and safety. In the event of injury, the wound must be immediately cleaned and disinfected. In the event of more serious injuries, seek a doctor's advice.
- Should it be necessary to change individual parts, use only original parts. Non-adherence to these requirements may put the user and other people's health and life at risk, and also damage the machine and invalidate the warranty.
- Regularly check technical condition and mounting of all guards and protective elements.
- Before welding or electrical work, the sand spreader should be disconnected from the electrical system. The paint coating should be cleaned. Burning paint fumes are poisonous for people and animals. Welding work should be carried out in a well lit and well ventilated space. Before beginning work, prepare a CO₂ or foam extinguisher.
- Any maintenance work should be performed when the machine is mounted on the carrier vehicle or supported on properly secured parking stands.
- The machine must not be supported using fragile elements (bricks or concrete blocks).
- After completing work associated with lubrication, remove excess of lubricant.
- Used lubricants should be disposed of.
- In order to reduce the danger of fire the machine must be kept in a clean condition.

CLEANING OF THE MACHINE

The machine should be cleaned as needed.

Before using the pressure washer the user is obliged to acquaint himself with the operating principles and recommendations concerning safe use of this equipment.

- Before washing, remove manually and as accurately as possible any remaining spread material.
- The machine may only be washed with clean running water. Cleaning detergents with neutral pH may be used, which do not react aggressively with the machine's structural elements.
- The use of a pressure washer increases

washing effectiveness but care must be taken during work. During washing, the washer nozzle may not be placed closer than 50 cm from the cleaned surface.

- Water temperature should not exceed 55°C.
- Do not aim the water jet directly at system and



DANGER

Carefully read the instructions for application of detergents and maintenance preparations.

While washing with detergents, wear appropriate protective clothing and goggles protecting against splashing.

equipment components, i.e. valves, bearings, electric and hydraulic plugs, lights, electrical connectors, information and warning decals, nameplate, connectors, lubrication points, control panels, safety switches etc. High pressure water jets may get inside the machine and cause mechanical damage or corrosion.

- Do not apply organic solvents, preparations of unknown origin or other substances, which may cause damage to lacquered, rubber or plastic surfaces. In the event of doubt it is recommended to make a test on an unseen surface area.
- Surfaces smeared with oil or grease should be cleaned by application of white spirit or other

degreasing agents and then washed with clean water with added detergent. Follow the cleaning agent manufacturer instructions.

- Detergents should be kept in original containers, optionally in replacement containers, but very clearly marked. Preparations may not be stored in food and drink containers or in unmarked containers.
- Ensure cleanliness of elastic conduits and seals. The plastic from which these elements are made may be susceptible to organic substances and some detergents. As a result of long-term reaction of some substances, the ageing process may be accelerated and risk of damage increased. Rubber elements should be maintained with the aid of special preparations after previous thorough washing.
- Observe the environmental protection rules, wash the machine in places designed for this purpose.
- Washing and drying the machine must take place at temperature above 0°C.
- Electronic components and control panel may be cleaned only with a soft cloth.
- Each time after washing the machine perform maintenance lubricate the machine.

F.2.4.470.04.1.EN

2.5 SAFETY DURING MACHINE OPERATION

- Before using the spreader always check its technical condition. In particular, check the technical condition of indicator lights, spreading mechanism, feeding mechanism and protective shields.
- The spreader drive can be started only when there are no bystanders or animals in the immediate vicinity of the machine working area. The machine operator is obliged to ensure proper visibility of the machine and the working area.
- During machine operation do not occupy a different position than that of the operator in the vehicle's cab. Do NOT leave the cab, when the machine is in operation.
- There must be no bystanders within the machine spreading zone.
- Do not approach the machine until the rotating parts come to a complete standstill.
- When working near pavements or on public roads there is a risk that thrown out particles of sand, salt, stones etc. may pose a threat to bystanders.
- Before loading sand spreader make certain that there are no stones, tools or other objects in the load box and on the spreading disc.
- Load should be uniformly distributed in the machine tank.
- Do NOT exceed permissible load weight of sand spreader because this may cause danger to road traffic and cause damage to the machine.
- Spreading agents must be prepared in accordance with the regulations concerning winter road maintenance in force in the country in which the sand spreader is used. Spreading agents other than those recommended by the Manufacturer must not be used.
- While working with the sand spreader, turn on the beacon light and the light near the spreading disc.
- Exercise extra caution while reversing.
- When spreading is completed, disengage the hydraulic drive of the feeding and spreading mechanisms.
- When driving on public roads, observe all road traffic regulations in force in the country, in which the machine is used.
- Adjust speed to the prevailing road conditions and other limitations arising from road traffic regulations.
- Do not carry people or animals on the machine.
- Reckless driving and excessive speed may cause accidents.

F.2.4.470.05.1.EN

2.6 RESIDUAL RISK

Pronar Sp. z o. o. in Narew has made every effort to eliminate the risk of accidents. There is, however, a certain residual risk, which could lead to an accident, and this is connected mainly with the actions described below:

- using the machine for purposes other than those for which it is intended,
- being between the carrier vehicle and the machine while the machine is being attached,
- being on the machine when it operates,
- operating the machine with removed or faulty safety guards,
- not maintaining a safe distance from the danger zone or being within the zones while the machine is operating,
- operation of the machine by unauthorised persons or persons under the influence of intoxicating substances,
- cleaning, maintenance and technical checks

when carrier vehicle is connected and engine is running.

The residual risk may be kept to a minimum by following the recommendations below:

- operate the machine in prudent and unhurried manner,
- reasonably apply all the remarks and recommendations stated in the Operator's Manual,
- carry out repairs and maintenance work in line with operating safety rules,
- repair and maintenance work should be carried out by persons trained to do so,
- use close fitting protective clothing,
- ensure unauthorised persons have no access to the machine, especially children,
- maintain a safe distance from prohibited or dangerous places
- do not climb on the machine when it is operating

F.2.4.470.07.1.EN



2.7 INFORMATION AND WARNING DECALS



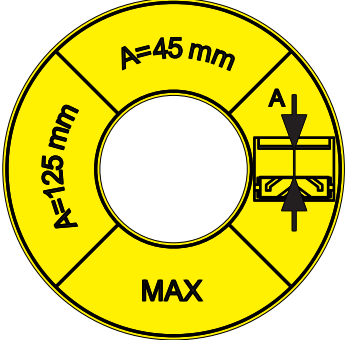
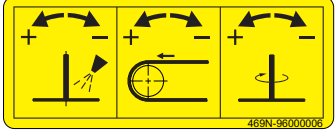

The machine is labelled with the information and warning decals mentioned in table 2.1. Throughout the machine use, make sure that any warning messages and information decals located on the machine are clear and legible. If any are destroyed or damaged, they must be replaced with new. New assemblies, changed during repair, must be labelled once again

with the appropriate safety signs. During machine cleaning do not use solvents, which may damage the coating of information decals and do not subject them to strong water jets.

F.2.4.415.08.1.EN

Table 2.1. Information and warning decals

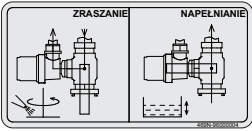
Item	Decal	Meaning
1		Machine model 470N-96000001
2		Information decal Control of the feeding mechanism barrier (469N-96000002)
3		Information decal Manual control of hydraulic block 496N-96000006
4		Danger caused by materials thrown out by the machine. Keep a safe distance from the operating machine. 12N-15000008
5		Before starting work Carefully read the Operator's Manual. 35N-27000007

Item	Decal	Meaning
6		<p>Lifting equipment attachment points while loading the machine 35N-27000009</p> <p>Attachment points for straps or chains securing the load to the carrier platform 35N-27000009</p>
7		<p>Information decal 187N-00000033</p>
8		<p>Do not enter the tank; do not stand on the feeding mechanism if the machine drive is engaged 254N-96000006</p>
9		<p>Information decal Control of the brine valve 469N-96000004</p>
10		<p>Outline marking. R1F TYP 1 DIN 11030</p>

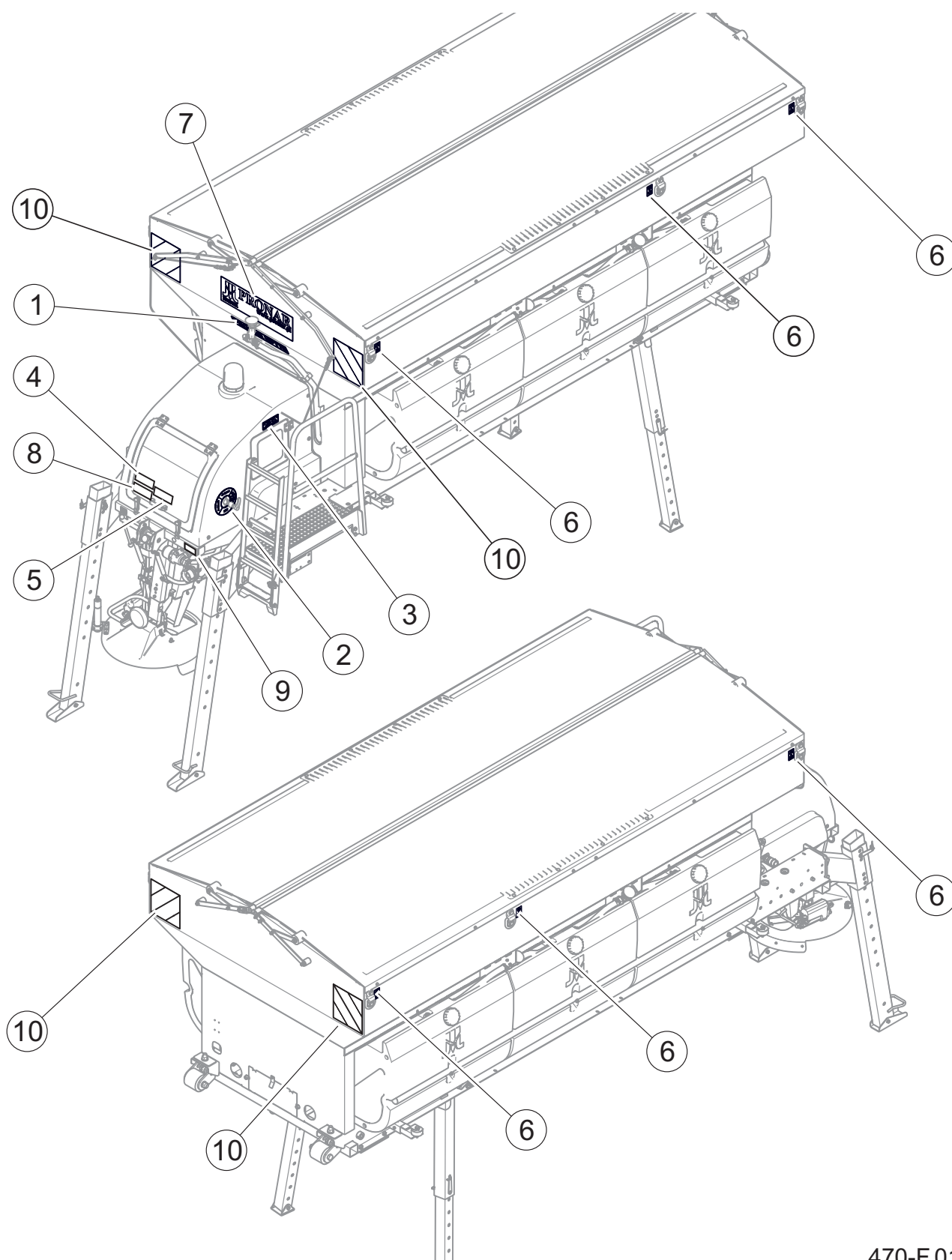

470-F.01-1

Figure 2.1 Locations of information and warning decals
Meaning of symbols (TABELA 2.1)

SECTION 3

DESIGN AND OPERATION

3.1 TECHNICAL SPECIFICATION

Table 3.1. Basic technical specification of the spreader

Contents	unit	PRONAR HPT70
Mounting method	–	on the carrier vehicle's load box by means of LC 2500N securing belts according to EN 121952 standard
Spreading width:		
– chemical agents	m	2 – 12
– coarse materials	m	2 – 6
Spreading density:		
– chemical agents	g/m ²	5 – 40
– coarse materials	g/m ²	50 – 200
Tank capacity	m ³	7* / 8* / 9*
Capacity of brine tanks	dm ³	2,700
Number of spreading discs	pc.	1
Number of spreading disc blades	pc.	6
Machine drive	–	external carrier vehicle hydraulic system
Control	–	with the aid of the control panel, from the operator cab
Electric power supply	V	24V
Pressure in the hydraulic system	MPa	21
Working speed	km/h	10 – 70
Machine weight (without load)	kg	2,380*/2,415*/2,450*
Height of the machine from the carrier vehicle's load box	mm	1,635* / 1,745* / 1,855*

* - depending on the installed tank size

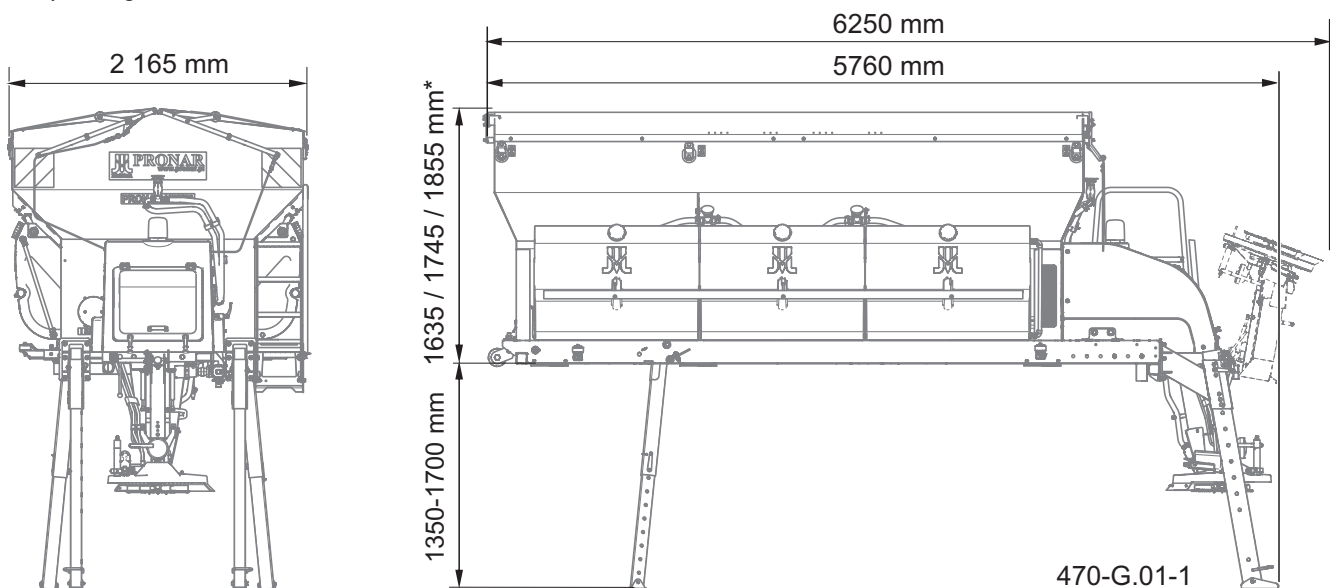
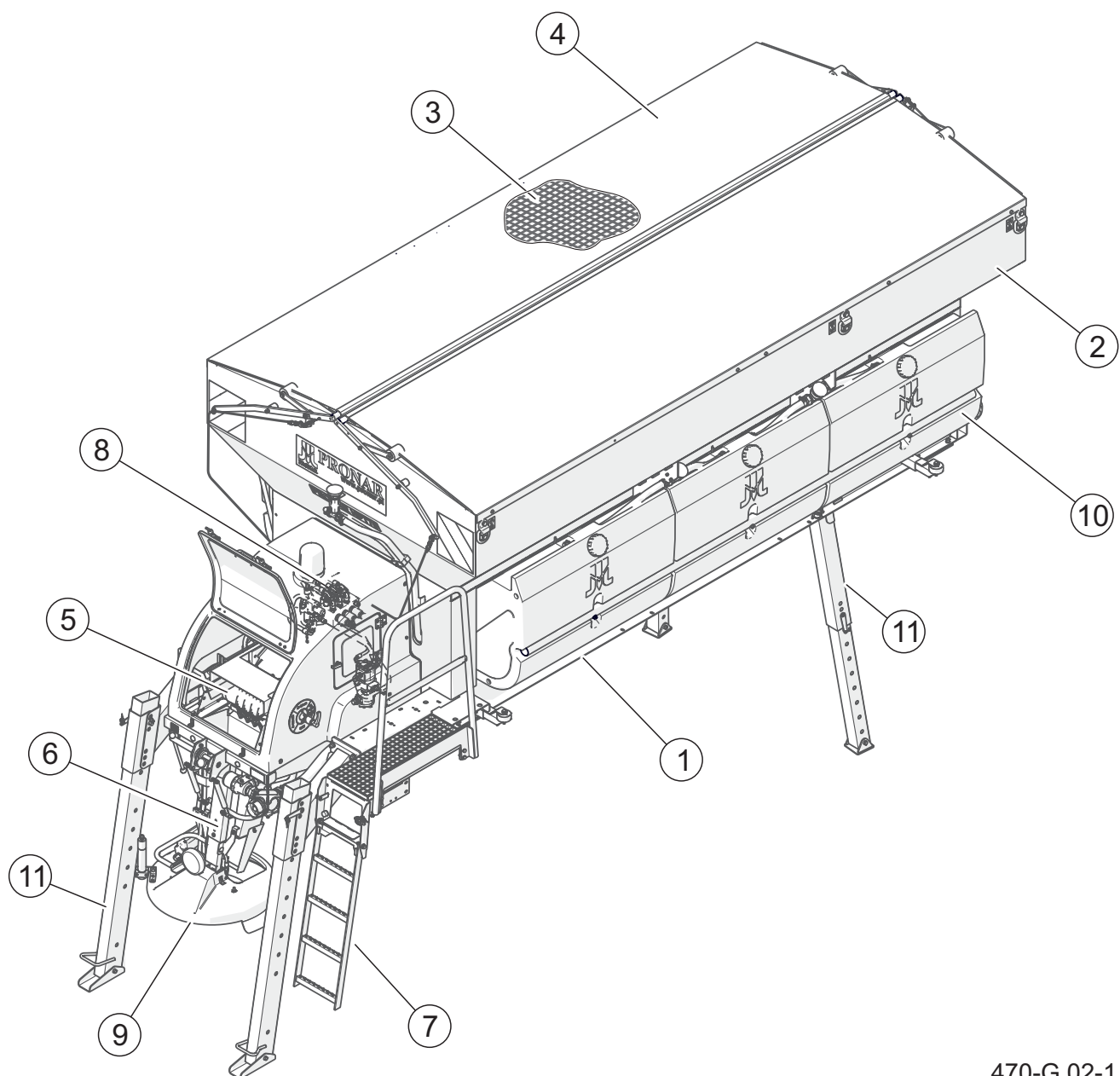

Figure 3.1 External dimensions of HPT70 spreader. * - depending on the installed tank size

3.2 GENERAL DESIGN



470-G.02-1

Figure 3.2 HPT70 general design

(1) frame

cover

ladder

spray system

(2) tank

(5) belt conveyor

(8) hydraulic system

(11) parking supports

(3) screen

(6) hopper system

(9) spreading system

(4) tarpaulin

(7) platform with

(10) tank of brine

The spreader consists of a frame (1) with a mounted tank (2) equipped with a screen (3) and a frame with tarpaulin cover (4). Belt conveyor (5) located at the bottom of the tank carries the material to the hopper system (6), which feeds the material to disc blades of the spreading mechanism (9). Additionally, the brine

spray system (10) makes it possible to feed the brine to the spreading mechanism. The sand spreader is equipped with its own hydraulic system (7) supplied from the carrier's hydraulic system. Working parameters are monitored and controlled from the carrier vehicle's cab by means of a control panel.

G.2.4.470.02.1.EN

3.3 HYDRAULIC SYSTEM

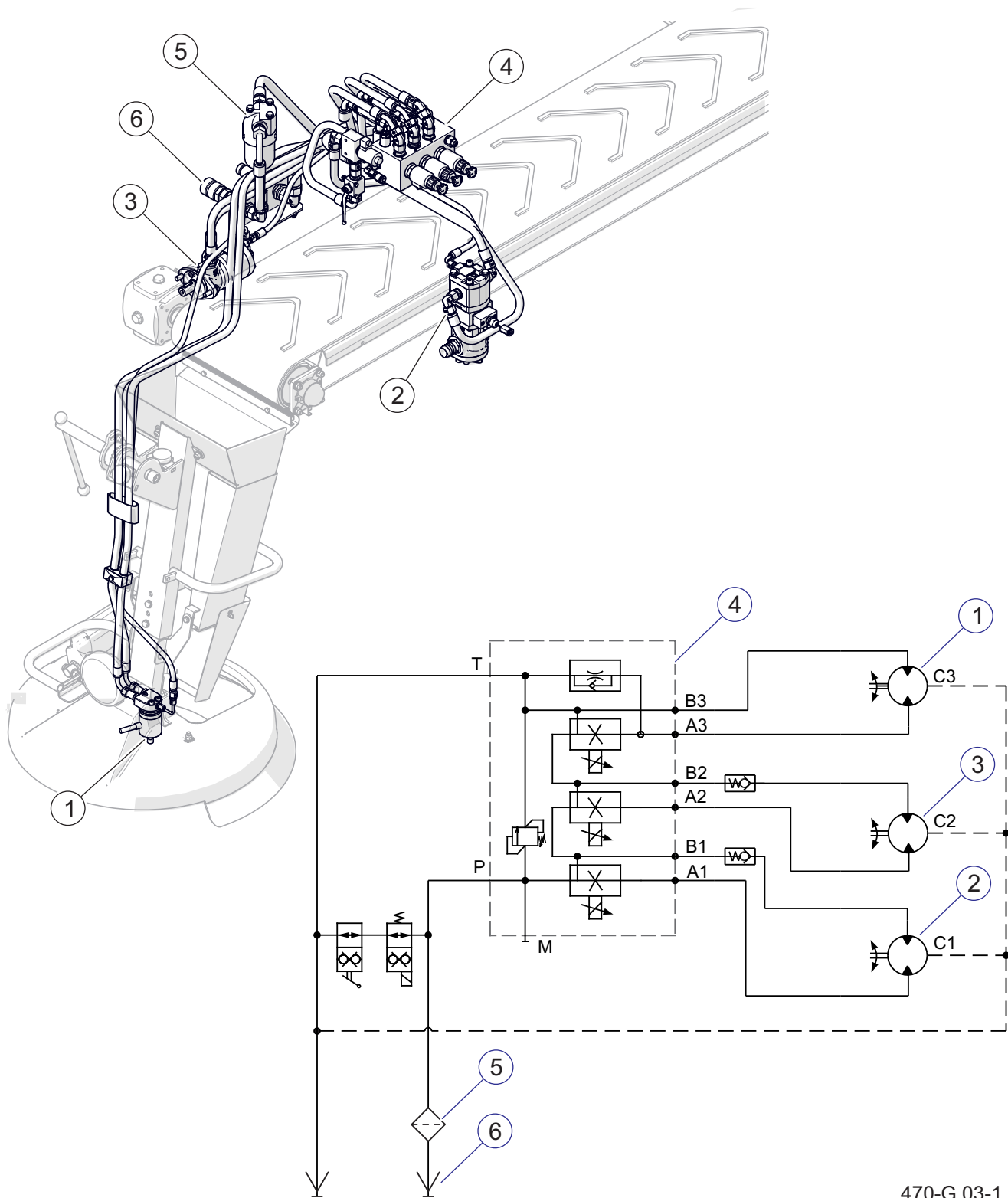

470-G.03-1

Figure 3.3 Design and diagram of hydraulic system

(1) hydraulic motor of the spreading disc

(2) conveyor hydraulic motor

(3) brine pump hydraulic motor

(4) hydraulic block

(5) pressure filter (option)

(6) hydraulic quick couplers,

3.4 BRINE SPRAY SYSTEM

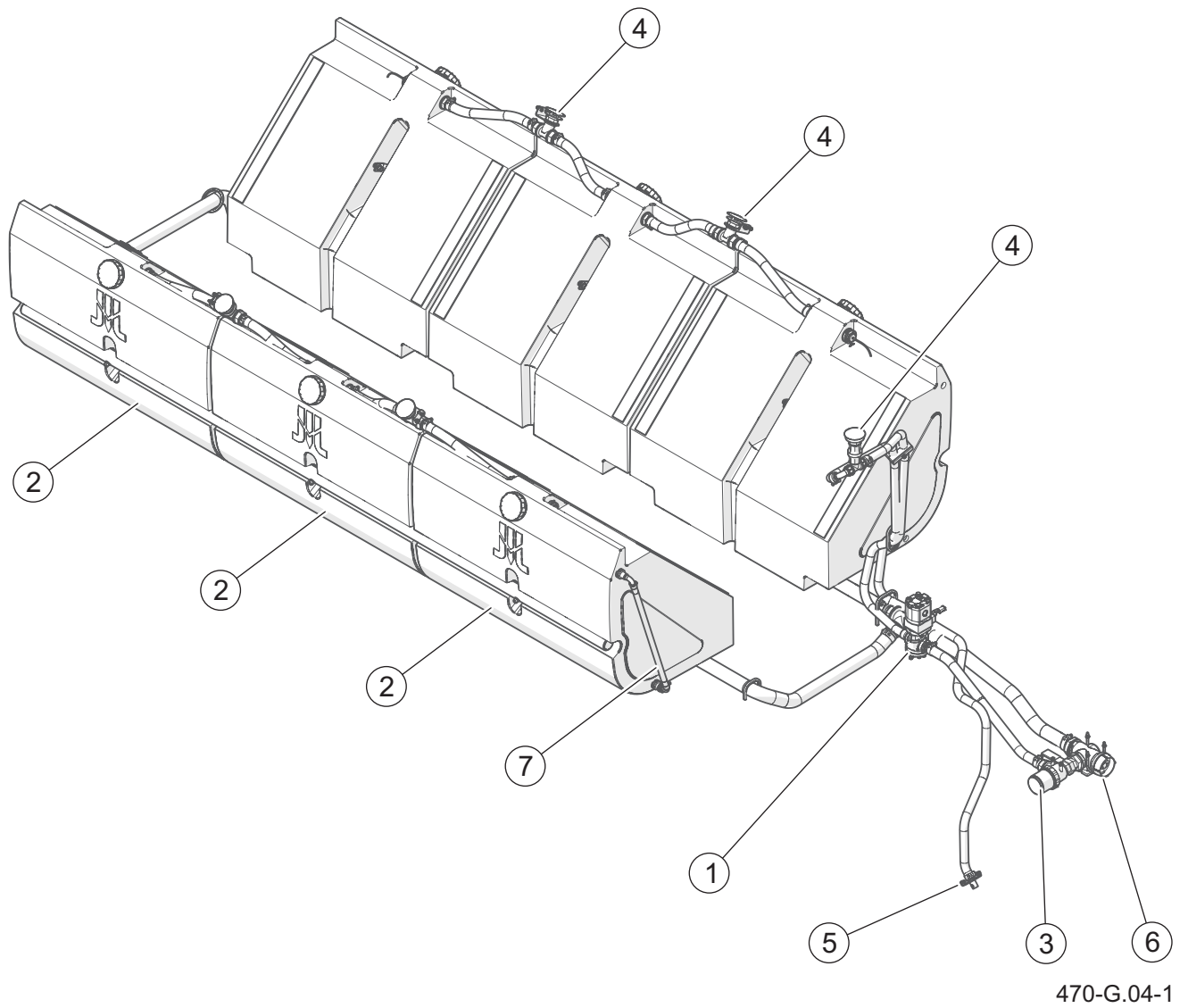
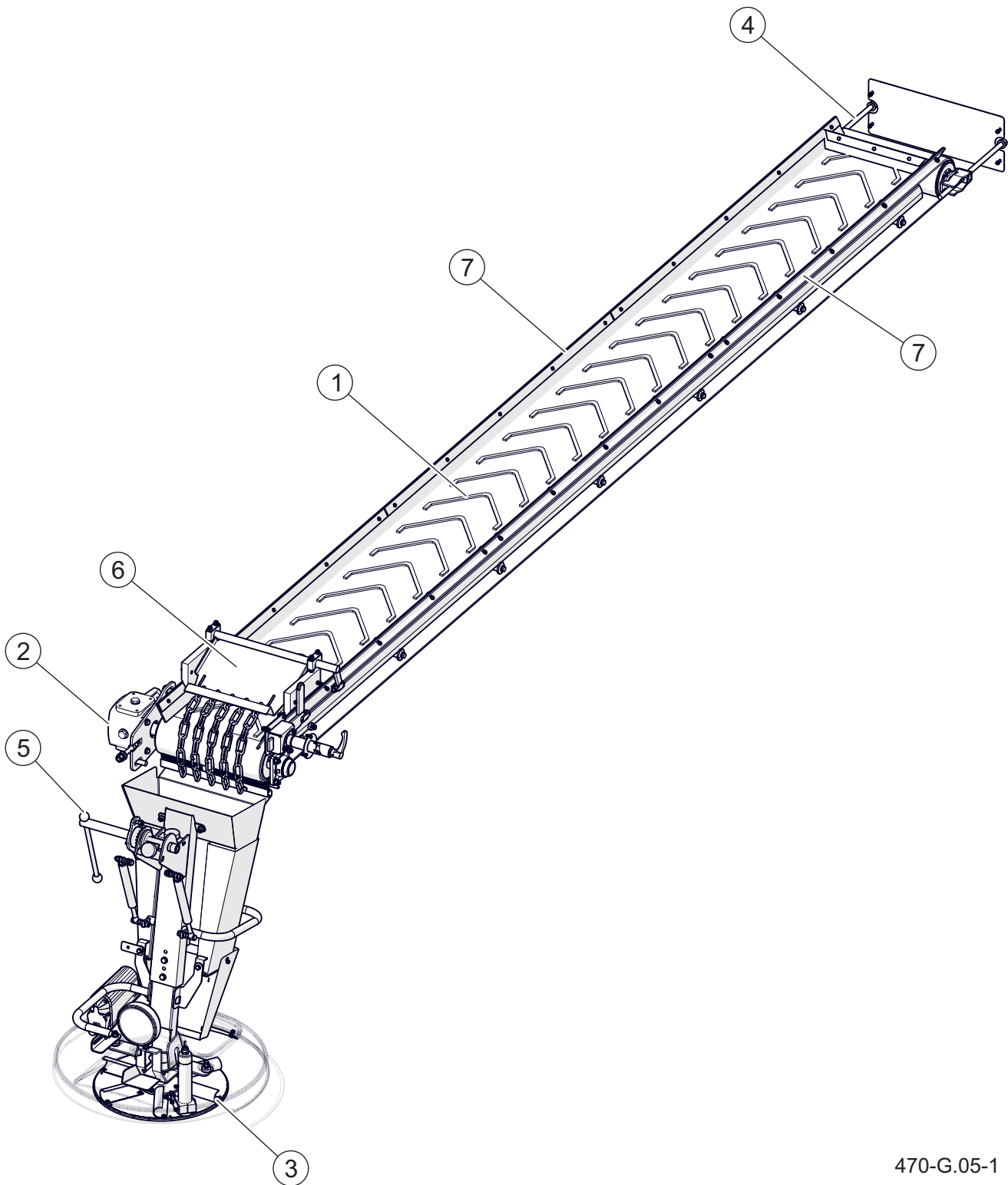

Figure 3.4 Design of brine spray system
(1) pump (2) tank (3) filter (4) air vent (5) sprinkler stub pipe
(6) filling valve (7) brine level indicator

G.2.4.470.04.1.EN

3.5 HOPPER AND SPREADING SYSTEM



470-G.05-1

Figure 3.5 Design of hopper and spreading system

(1) belt conveyor
(6) screen

(2) gear (3) spreading disc
(7) conveyor seals

(4) conveyor tensioner (5) lifting interlock lever

G.2.4.470.05.1.EN

3.6 ELECTRICAL SYSTEM

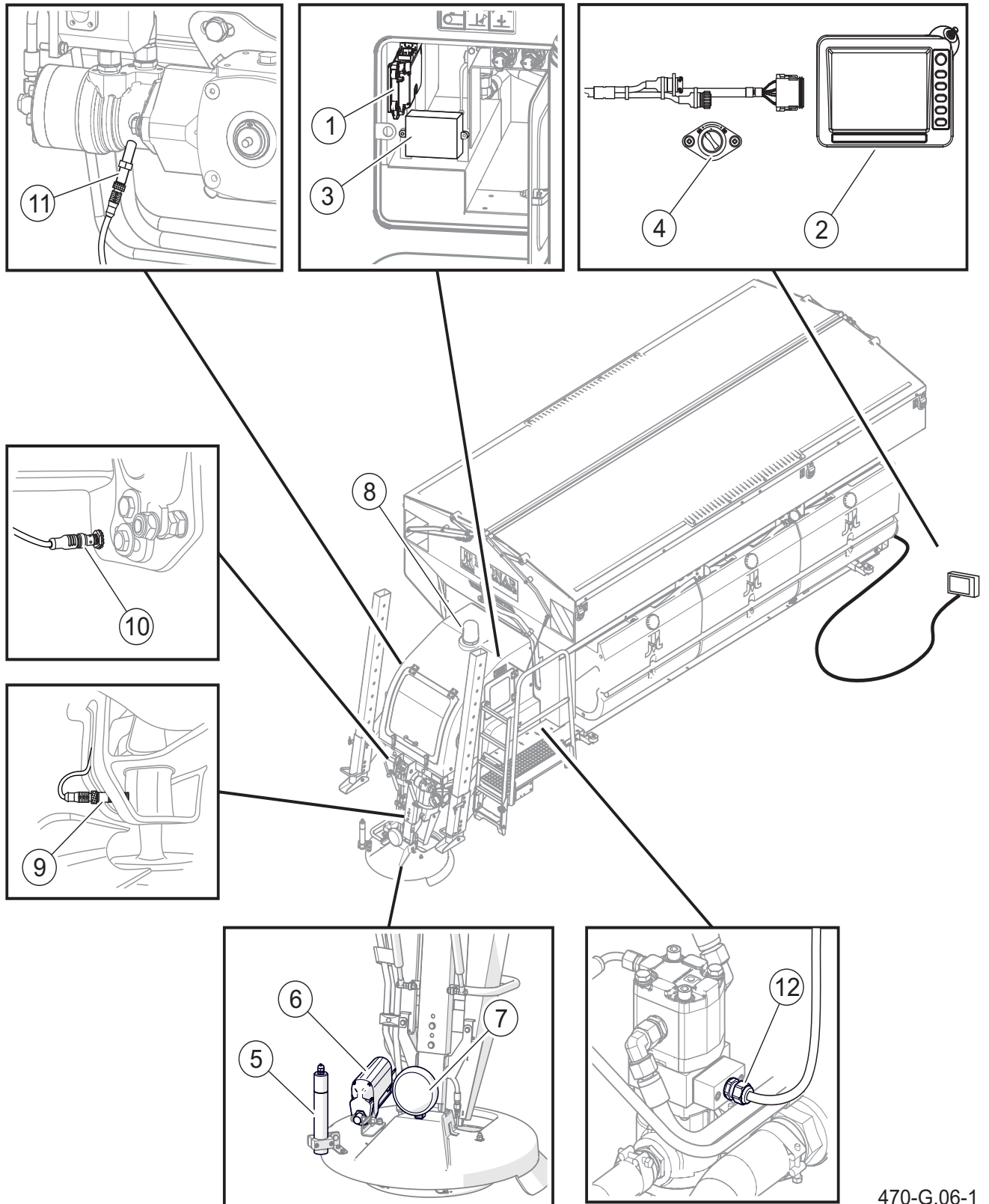

470-G.06-1

Figure 3.6 Electrical system design

- | | | | | |
|---|------------------------------|------------------|-----------------------|---------------------------------------|
| (1) controllers | (2) control panel | (3) fuses | (4) main switch | (5) spreading sensor |
| (6) spreading direction adjustment cylinder | (7) rear red lamp | (8) beacon light | (9) disc speed sensor | (10) spreading mechanism raise sensor |
| (11) belt speed sensor | (12) brine pump speed sensor | | | |

SECTION 4

CONTROL PANEL

4.1 CONTROL PANEL

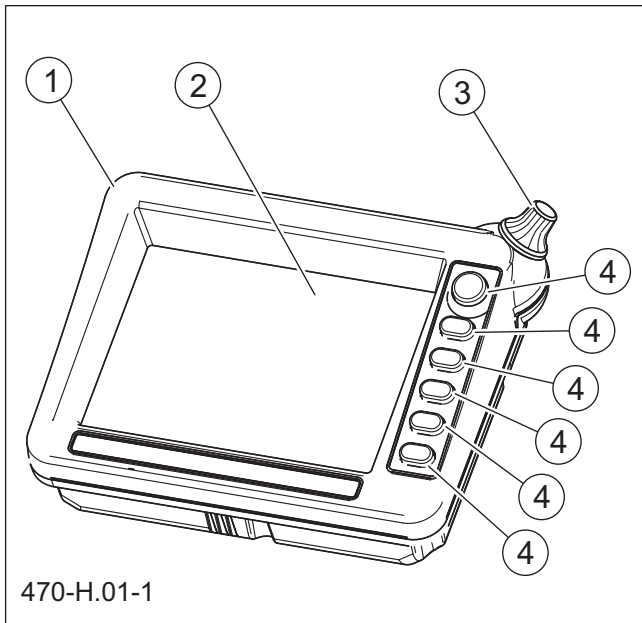

Figure 4.1 General design of control panel
 (1) housing (2) LCD
 (3) parameter adjust knob (4) function buttons

Control panel – figure (4.1) consists of enclosure (1), colour LCD display (2), parameter change knob (3) and six function push-buttons (4).

Depending on a display menu page selected, – figure (4.3) currently assigned functions (B) are displayed next to function push-buttons (2), (3), (4), (5), (6), (7). On each display menu page, different functions are

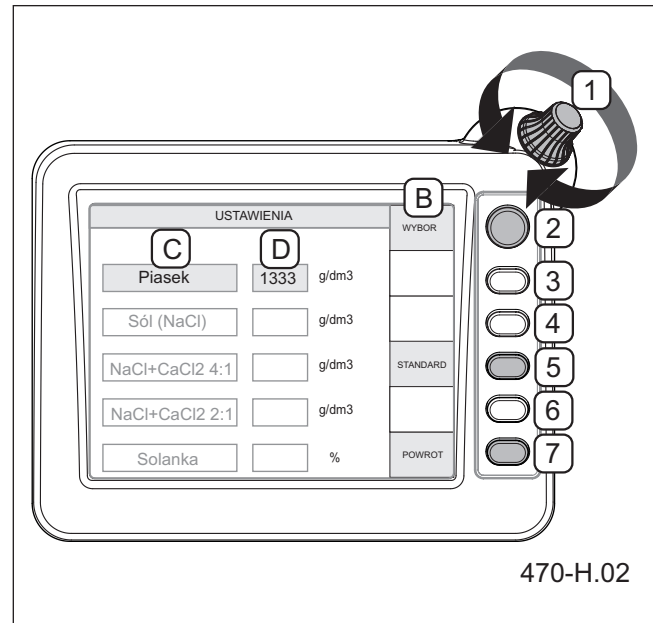

Figure 4.2 Example of control panel operation
 (1) parameter adjust knob (2)-(7) function buttons
 (B) button function name (C) parameter name field
 (D) parameter value field

displayed for a given push-button. Empty function field next to a (3), (4), (6) button means that a button is not active at the time. Use knob (1) to go to another field (C) or adjust parameters in the field (D).

H.2.4.415.01.1.EN

4.2 CONTROL PANEL MENU

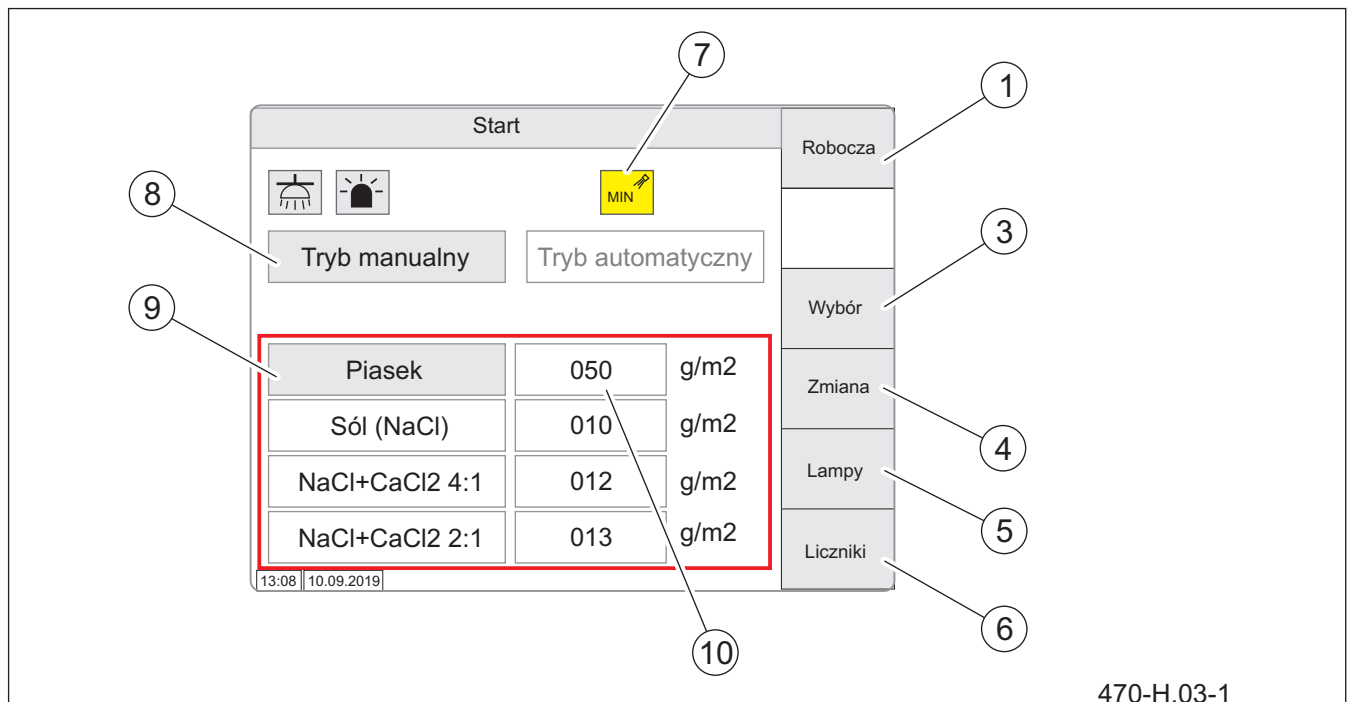
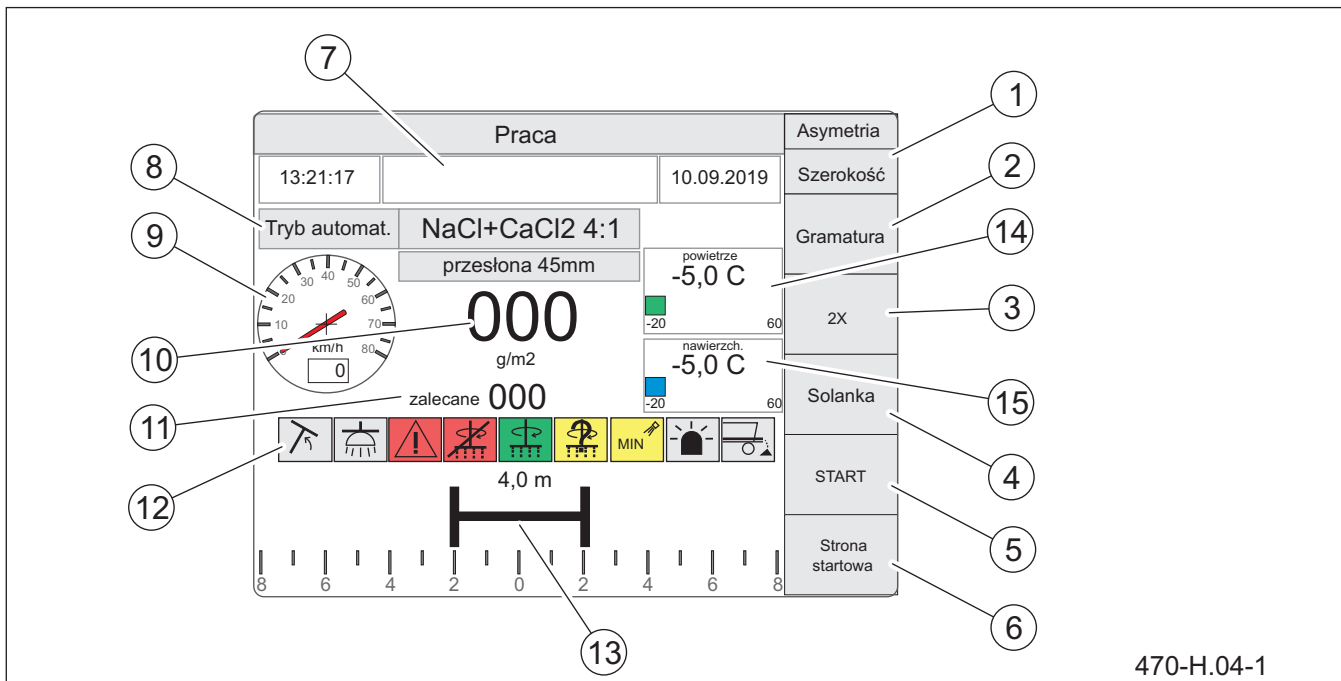

Figure 4.3 Control panel display home page
Meaning of home page functions - see TABLE 4.1

Table 4.1. Home page functions

Marking Figure 4.3	FUNCTION name	Description
1	Operation	Go to operation page
3	Select	Select a field for editing: * - automatic mode / manual mode - selecting a spreading material
4	„Edit”	Edit a selected field
5	„Lights”	Turn on warning lights
6	Counters	Go to counters page
7	-	Information and warning indicators
8	Manual mode Automatic mode	Manual or automatic operation mode is active (option)
9	Sand	Currently selected spreading material
10	„030 g/m2”	Preliminary setting of spreading density for a currently selected material

** - Active selection is marked with a red frame.



470-H.04-1

Figure 4.4 Operation page of control panel display
 Operation page functions, see TABLE 4.2

Table 4.2. Operation page functions

Marking Figure 4.4	FUNCTION name	Description
1	Asymmetry Width	Edit asymmetry and spreading width
2	Spreading density	Edit spreading density
3	„2X”	Double dose
4	Brine	Activate brine spraying
5	Start	Activat spreading
6	Home page	Go to Home Page
7	-	Messages and indicator lights window
8	Automatic mode "NaCl + CaCl ₂ 4: 1" "45mm screen"	Currently selected operating conditions
9	0 km/h	Ground speed
10	„000 g/m ² ”	Defined density
11	"recommended 000"	Recommended density in automatic mode
12	-	Information and warning indicators
13	„4 m”	Spreading pattern (width and asymmetry)
14	"air -5,0C°"	Air temperature (option)
15	road surface -5,0C°"	Road surface temperature (option)

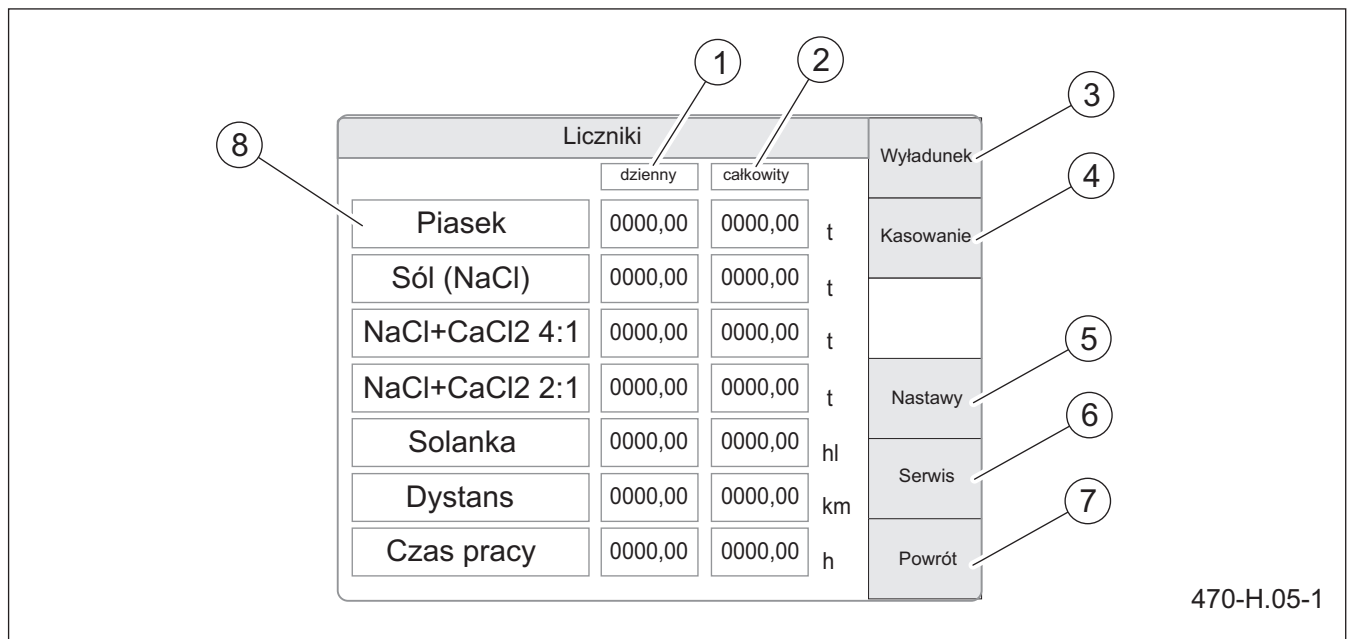

Figure 4.5 Counter page of control panel display
Counters page functions, see TABLE 4.3

Table 4.3. Counters page functions

Marking Figure 4.5	FUNCTION name	Description
1	daily	Daily material counter - resettable
2	total	Total material counter - non-resettable
3	Unload	Start unloading
4	Reset *	Resetting (zeroing) of daily counter
5	Settings	Go to Settings page (enter a password to access the page)
6	Service	Go to Service page (enter a password to access the page)
7	Back	Back to previous page
8	Sand	Type of material

H.2.4.470.02.1.EN

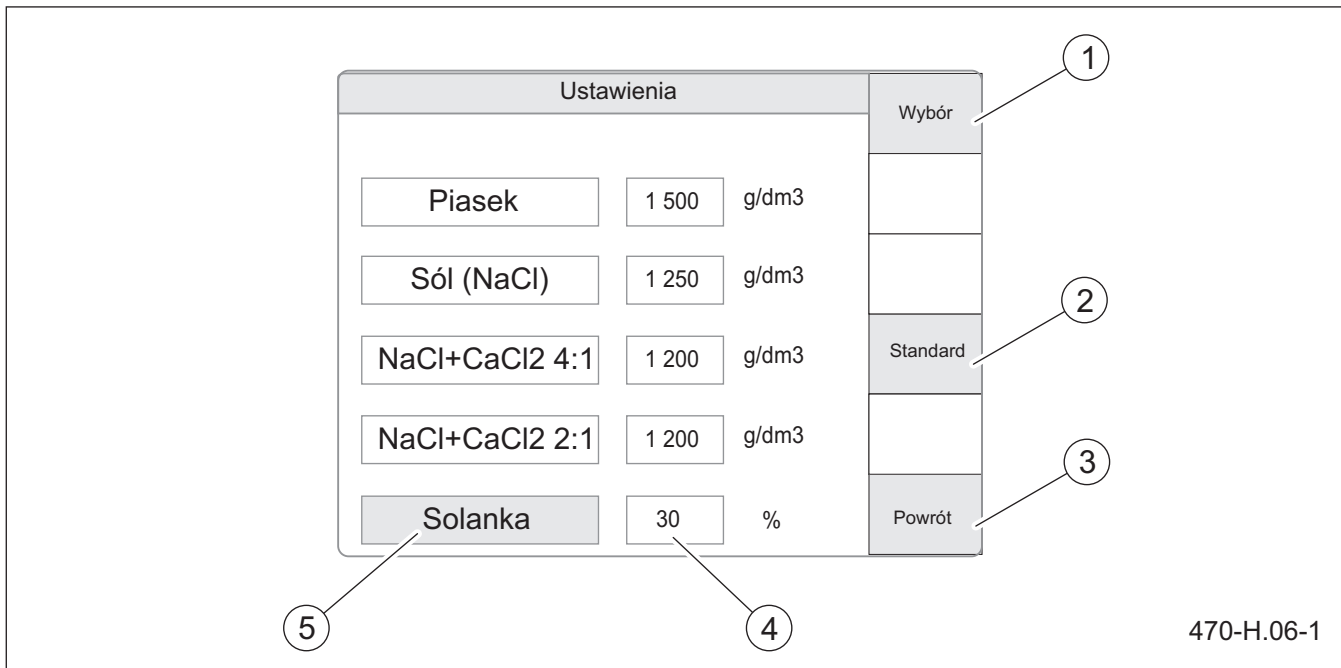

Figure 4.6 Control panel material settings page – "Settings"
Material settings page functions, see TABLE 4.4

Table 4.4. Material settings page functions

Marking Figure 4.6	FUNCTION name	Description
1	Select	Selecting a type of spreading material
2	Standard	Select standard values
3	Back	Back to previous page
4	1500 g/dm ³ " „30%”	Material specific gravity setting and brine content percentage
5	Brine	Marked type of material to change

TIP

Use the knob on the control panel to adjust parameter values

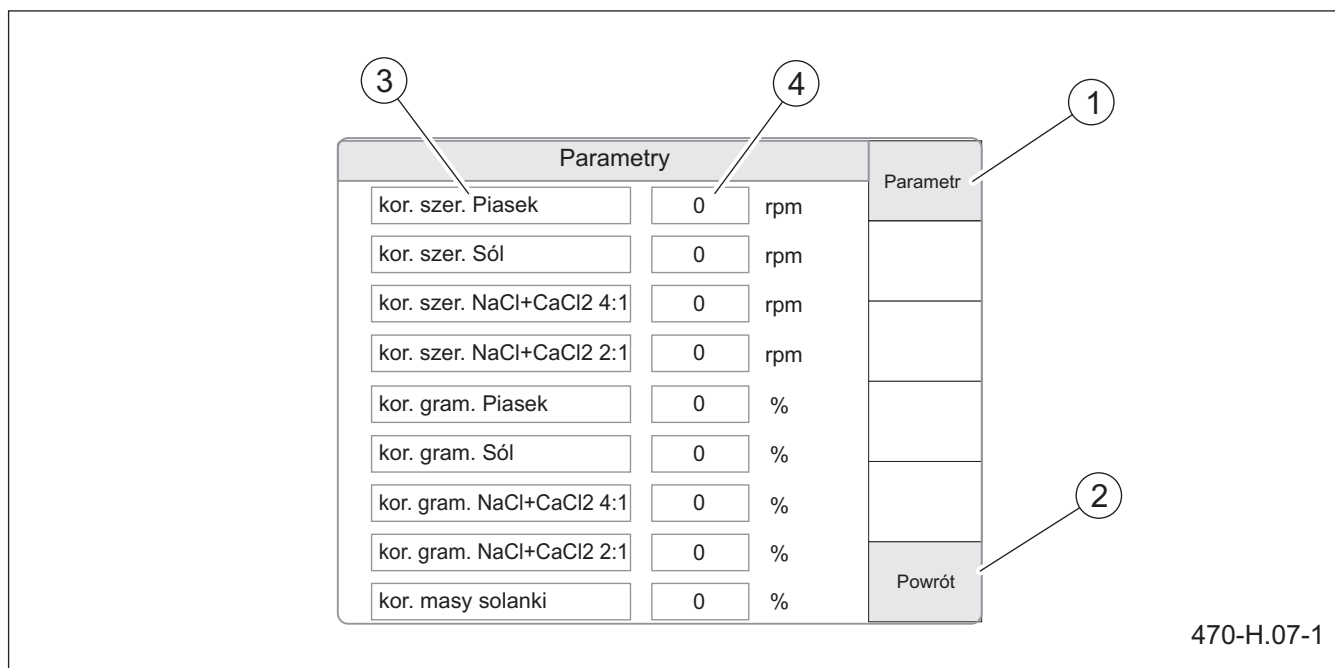

470-H.07-1

Figure 4.7 Parameter correction page
Parameter correction page functions, see TABLE 4.5

Table 4.5. Parameter correction page functions

Marking Figure 4.7	FUNCTION name	Description
1	„Parameter”	Selecting a parameter
2	Back	Back to previous page
3	"Sand width correction"	Select correction and material type
4	"0 rpm" or "0%"	Parameter correction value rpm - correction of rotations per minute % - percentage correction

TIP

A password must be given in order to enter the parameter correction page "Parameters".

TIP

Use the knob on the control panel to adjust parameter values

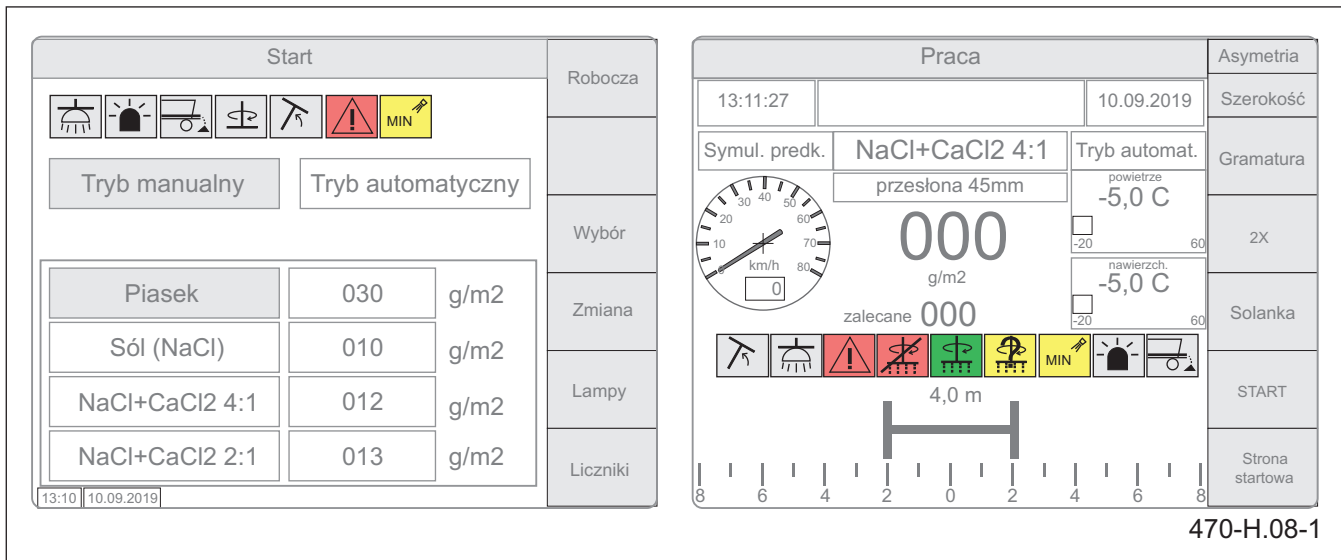

Figure 4.8 Arrangement of information-warning indicators

Table 4.6. Description of information-warning indicators on the control panel

Symbol	Description
	Disc raised (grey)
	Disc lamp is ON (grey)
	Error (red)
	No spreading (red)
	Spreading is active (green colour)

Symbol	Description
	Spreading problem (yellow)
	Minimum brine level (yellow)
	Beacon light is ON (grey colour)
	Unloading is ON (grey)

SECTION 5

CORRECT USE

5.1 GET READY FOR OPERATION BEFORE FIRST USE

The manufacturer guarantees that the machine is fully operational and has been checked according to quality control procedures and is ready for use. This does not release the user from an obligation to check the machine's condition after delivery and before first use. The machine is delivered to the user completely assembled. Prior to connecting to carrier vehicle, machine operator must verify the sand spreader's technical condition, prepare it for first use and configure as needed. In order to do this:

- the user must carefully read this Operator's Manual and observe all recommendations, understand the design and the principle of machine operation,
- check technical condition of protective shields and confirm that they open and close correctly,
- Visually inspect the machine components for mechanical damage resulting from, for example, incorrect shipping.
- make sure the brine tanks are secure before filling,
- check the condition of protective paint coat,
- check all the lubrication points, lubricate the machine as needed according to recommendations provided in section 5,
- check all nut and bolt connections,
- check if spreading discs and blades are correctly installed,
- check tension of conveyor belt.



IMPORTANT

Failure to follow instructions in this Operator's Manual or starting the machine incorrectly may cause damage to the machine. Before using the machine always check its technical condition. There must not be any doubt about technical condition. The machine must not be used when not in working order.

If all the above checks have been performed and there is no doubt as to the machine's good technical condition, it can be connected to carrier vehicle, started and all its individual systems checked.

In order to do this:

- connect the machine to carrier vehicle (see *MACHINE SETUP*),
- Connect electrical wiring and hydraulic system lines.
- check correctness of electrical system operation,
- check the tightness and operation of the hydraulic system and the brine sprinkler system,
- check operation of hopper system and spreading system,
- check the conveyor belt for correct operation.

In the event of a disruption in the operation of the machine immediately discontinue its use, find and remove the fault. If a fault cannot be rectified or the repair could void the warranty, please contact the Manufacturer for additional clarifications.



DANGER

Before using the machine, the user must carefully read this Operator's Manual

Misuse and careless operation of the machine and failure to follow the instructions given in this Operator's Manual may pose danger to health and life.

The machine must never be used by persons who are not authorised to drive carrier vehicle, including children, and people under the influence of alcohol or other substances.

Non-compliance with the safety rules of this Operator's Manual can be dangerous to the health and life of the operator and others.

Before starting the machine, ensure that there are no bystanders in the danger zone.

5.2 INSPECTIONS DURING DAILY OPERATION

- Conduct daily inspection according to the guidelines presented in sections *PERIODIC INSPECTION*, *MAINTENANCE*, and *LUBRICATION SCHEDULE*. If necessary, make the necessary repairs immediately.
- Check technical condition of protective shields and wear parts. Check if shields are complete and correctly closed.
- Check the technical condition of belt conveyor and spreading disc, if complete and correctly mounted.
- After completed work, check and possibly remove material accumulated near the tightening roller and on the internal surface of the conveyor belt.



IMPORTANT

Do NOT start the machine if its daily inspection was not carried out.



IMPORTANT

After completed work, check and possibly remove material accumulated near the tightening roller and on the internal surface of the conveyor belt.

I.2.4.470.02.1.EN

5.3 MACHINE SETUP

INSTALL THE MACHINE ON THE CARRIER VE- HICLE'S LOAD BOX



IMPORTANT

Before hitching the sand spreader to carrier vehicle, read the carrier vehicle operator's manual.



DANGER

When hitching, there must be nobody under and between the machine and the carrier vehicle.

Exercise caution when hitching the machine to carrier vehicle.

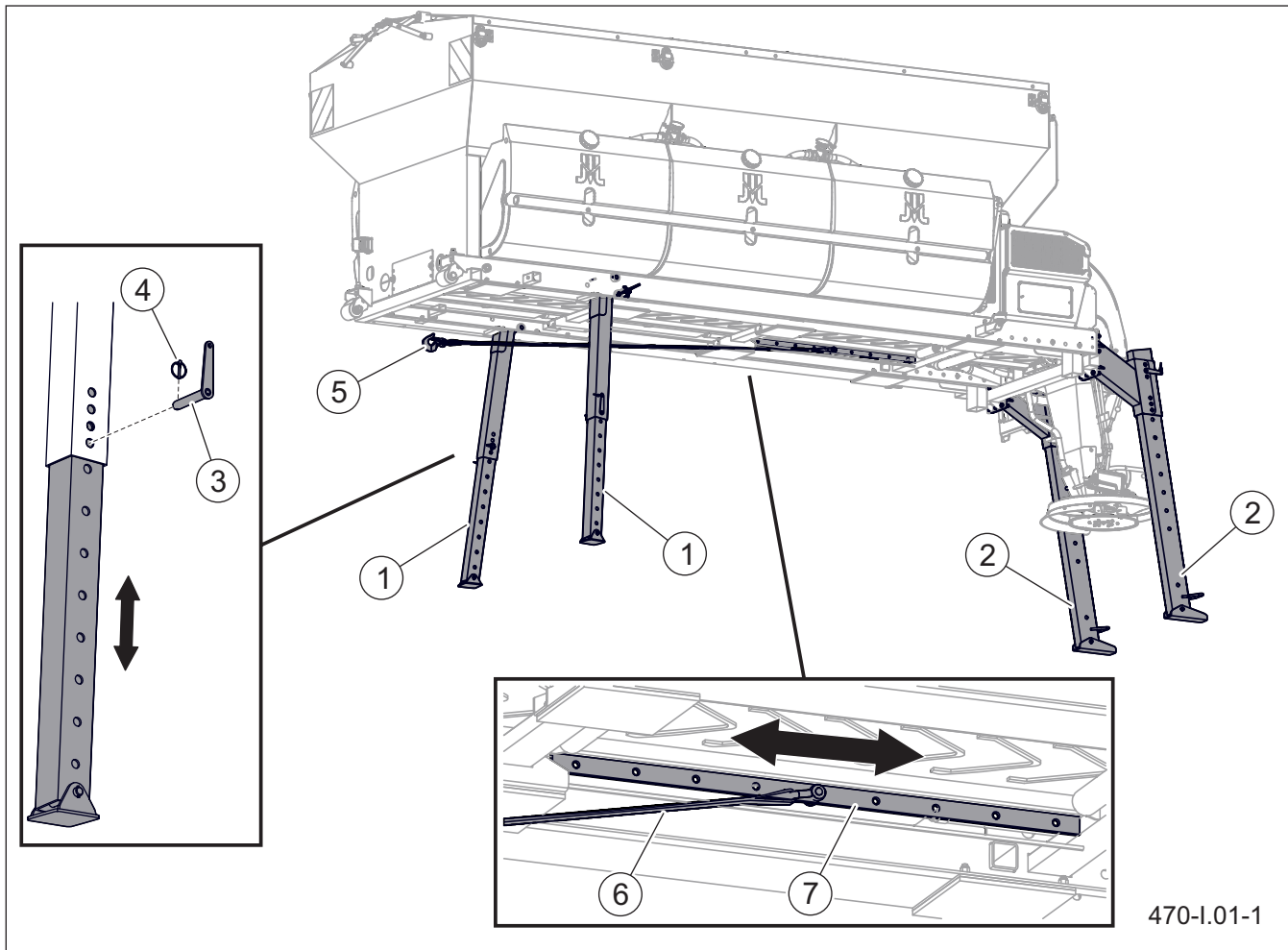

Figure 5.1 Parking supports

(1) front support (2) rear support (3) pin (4) cotter pin (5) hook (6) belt sling (7) fixing point

The spreader can be installed on the carrier vehicle that meets the requirements specified in Table 1.1 *Carrier vehicle requirements*.

The spreader is equipped with parking stands (figure 5.1). The height of parking stands should be adapted to the height of the carrier vehicle's load box. Lock the parking stands in their positions using pins (3) and secure with cotter pins (4).



IMPORTANT

Before installing the machine on the carrier vehicle, remove snow, ice and other contaminants from the carrier vehicle load box.

To set the sand spreader position on the carrier platform with side walls, use adjustable guides (2) with wheels (figure 5.2) and stops (7) installed from the bottom of

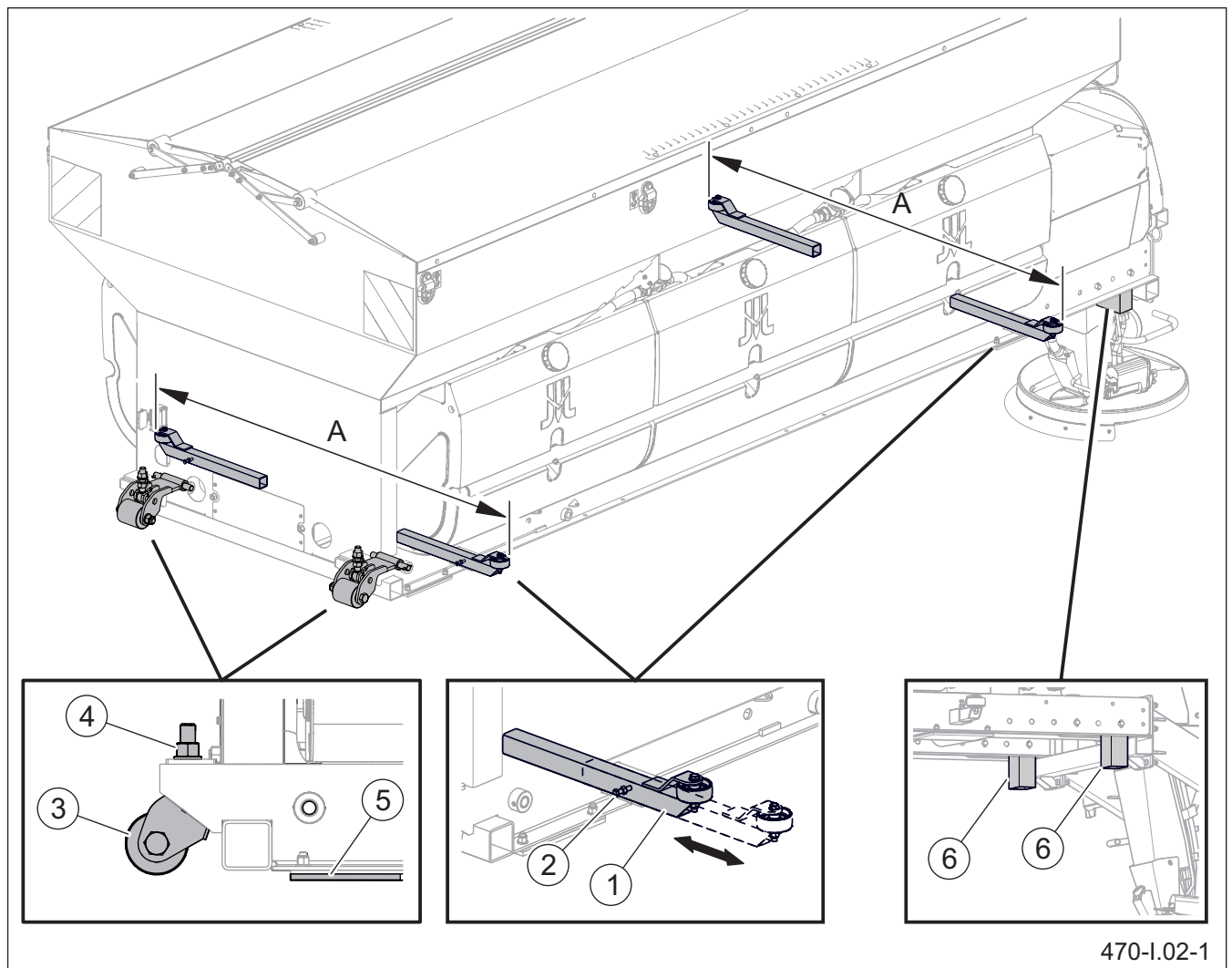

Figure 5.2 Guides

- (1) guide
- (2) compression bolt
- (3) roller
- (4) roller adjustment
- (5) rubber lining
- (6) bumper
- (A) dimension slightly smaller than the width of the load box

the frame in the rear of the machine. Set the front and rear guides (1) so as to ensure that dimension (A) is slightly smaller than the internal width of the carrier vehicle load box (figure 5.2).

Reverse the carrier vehicle and position the load box so as to ensure that the sand spreader is positioned symmetrically with regard to the right side and the left side of the load box.

Set the fixing point and attach the belt sling (6) ended with a hook (5) to a fixed and sufficiently strong element of the carrier vehicle (e.g. rear hitch) in order to prevent the machine from sliding off the platform (figure 5.1).

Raise the carrier load box until it rests on the rollers (3) (Figure 5.2).

Unlock the front parking stands (4) on both sides of the machine (figure 5.2) by unlocking cotter pins (6) and

removing securing pins (5). Relocate the pins from hole (I) in the spreader frame to hole (II) (figure 5.3).

Raise the load box to such a height (minimum 1,5°) as to ensure that rollers (3) (A – figure 5.3) are supported on the platform floor (the rollers should be set in such a manner as not to touch the platform floor when the machine is loaded).

While the carrier vehicle is being reversed with the load box raised, the front parking stands (4) will be raised

TIP

Guides (Figure 5.2) are used in carrier vehicles which have sufficiently strong side walls of the load box. The use of guides depends on how the machine is mounted on the load box (see MOUNT THE MACHINE ON THE CARRIER PLATFORM).

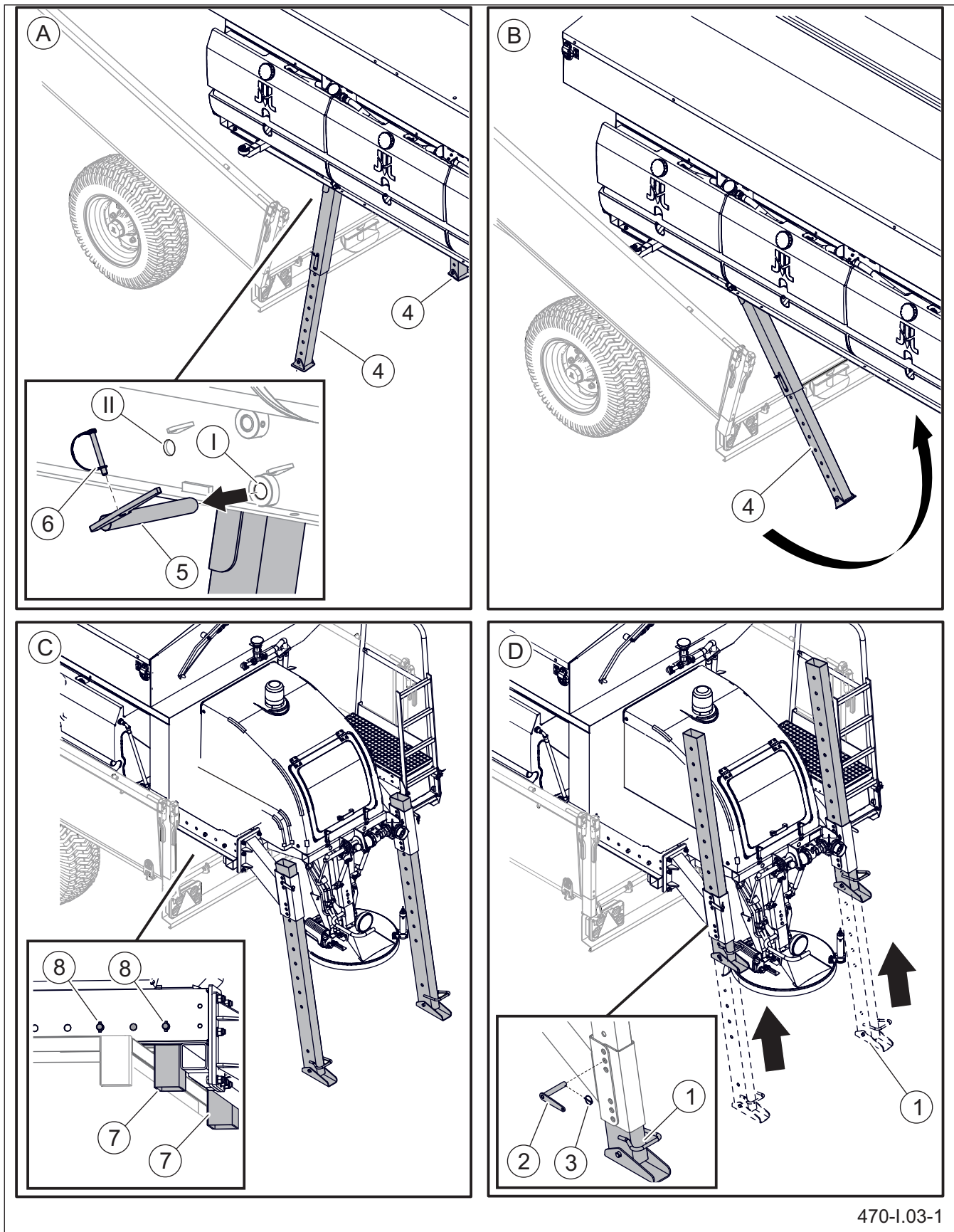

470-I.03-1

Figure 5.3 Stages of installing the machine on the carrier vehicle

- | | | | | |
|----------------------|------------|---------------------|----------------------------|-------------------------------|
| (1) rear support pin | (2) pin | (3) cotter pin | (4) front support | (5) front support lock |
| (6) cotter pin | (7) bumper | (8) bumper lock pin | (I) lock the front support | (II) unlock the front support |

above the ground and folded automatically (B - figure 5.3).

Reverse the carrier vehicle until the stops (7) rest on the rear edge of the platform. The position of the stops should set earlier by means of locking pins (8),

depending on the platform length (C - figure 5.3).

Lower the load box.

take out cotter pins (3) and slide out pins (2), Raise the rear parking stands (1) and secure them with pins (2) and cotter pins (3) (D - figure 5.3).

SECURE THE MACHINE TO THE CARRIER VEHICLE LOAD BOX

The machine positioned on the carrier vehicle should be secured to load box by means of fastening belts certified according to EN 12195-2 standard and fitted with a tightening mechanism. The spreader is equipped with four attachment points for straps (Figure 5.4). In order to correctly secure the sand spreader, the carrier vehicle's load box must be fitted with attachment points for fastening belts. Otherwise, install such points in a proper manner.

Permissible load of fastening belts and method of their attachment depend on a selected method of securing the machine to the carrier vehicle's load box.

Securing method 1 (figure 5.5) is used in case of carrier vehicles with weak or without side walls of load box. To secure the machine, use 4 LC 2 500 daN fastening belts according to EN 12195- 2 standard and attach them to special catches on the load box or to the load box side.

Securing method 2 (figure 5.6) is used in case of carrier



DANGER

DO NOT use the machine if it is not properly secured to the carrier vehicle's load box.

Secure the machine according to the rules for securing loads on vehicles moving on public roads.



IMPORTANT

Fastening belt may be used only if it is not damaged and has a legible label with a proper certificate according to EN-12195-2.



IMPORTANT

Install fastening belts in such a manner as to protect them against damage caused by sharp edges of the machine or carrier vehicle.

vehicles with strengthened side walls of load box. To secure the machine, use 4 LC 2 500 daN fastening belts according to EN 121952 standard and attach them to the load box side.

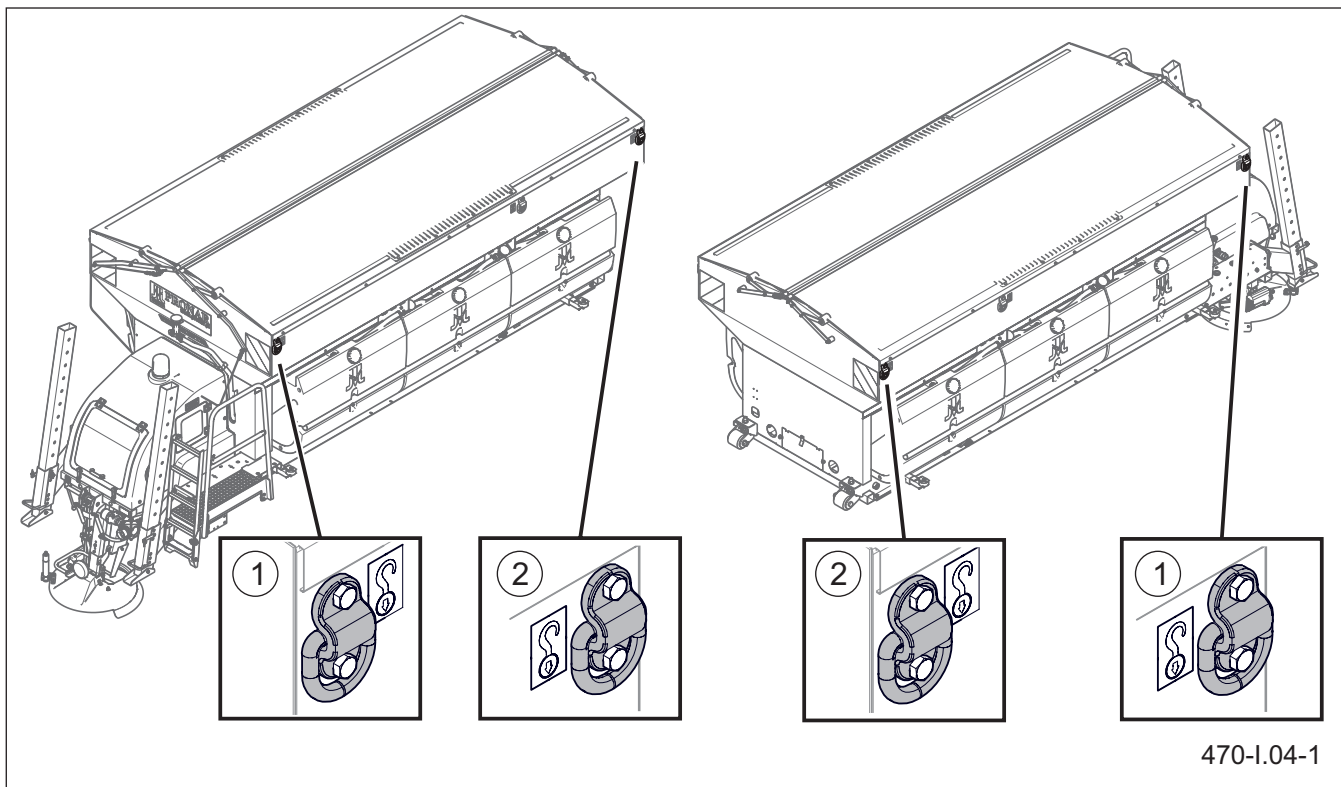

470-I.04-1

Figure 5.4 Attachment points for fastening belts
(1) rear belt attachment points (2) front belt attachment points

Permissible load of fastening belts and method of their attachment depend on a selected method of securing the machine to the carrier vehicle's load box.

Securing method 3 (figure 5.7) is used in case of carrier vehicles with strengthened side walls of load box. To secure the machine, use 4 LC 2 500 daN fastening belts according to EN 121952 standard.

 **DANGER**

If the carrier vehicle's load box has tipper function, turn off or lock this function to prevent accidental use, once the machine is installed.

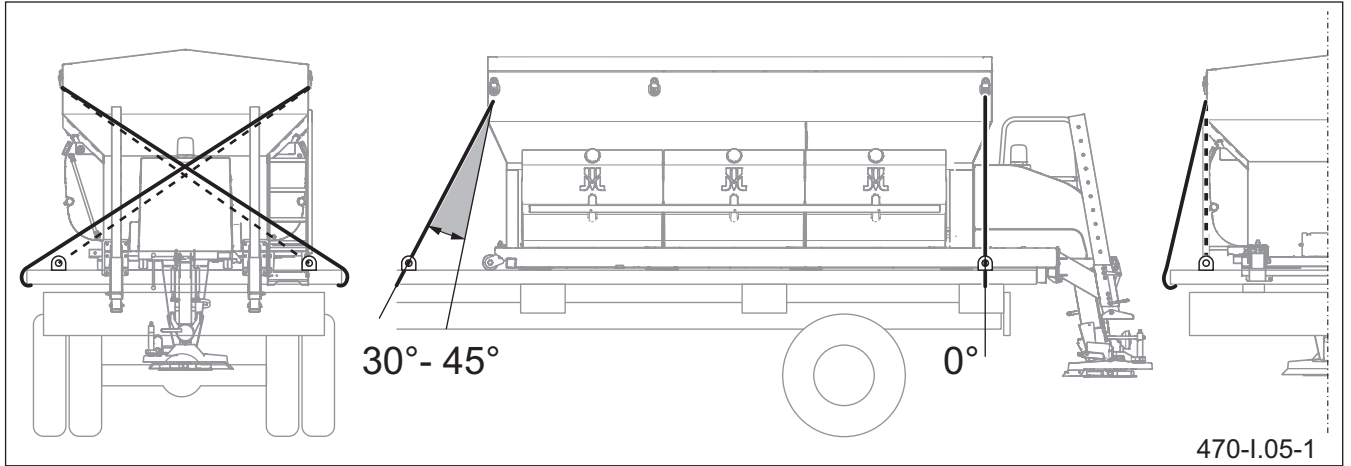

Figure 5.5 Securing method 1

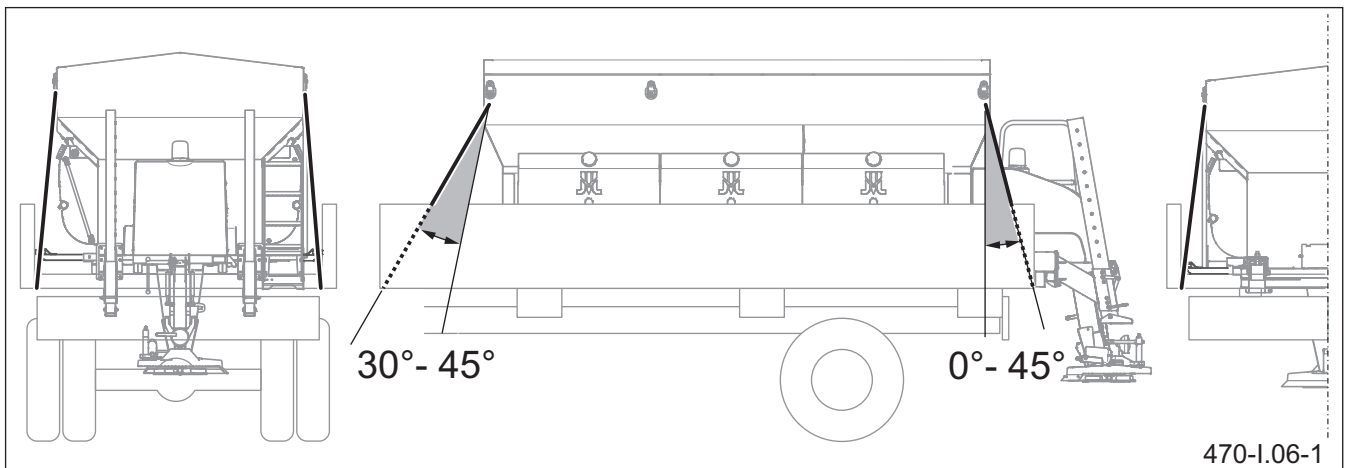

Figure 5.6 Securing method 2

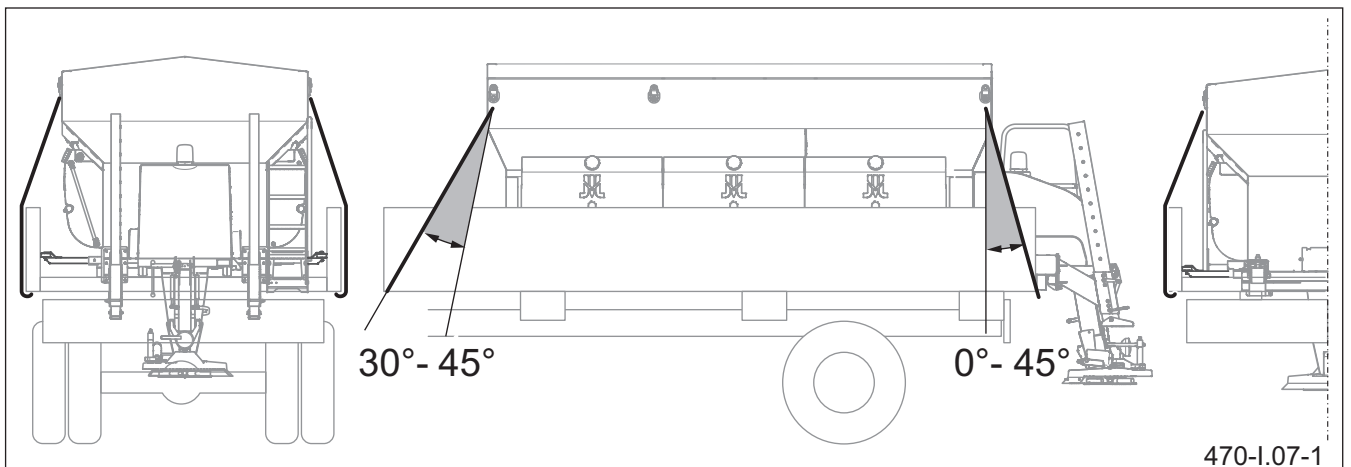

Figure 5.7 Securing method 3

CONNECT THE ELECTRICAL CONTROL SYSTEM

To ensure correct operation of the sand spreader's control system, the carrier vehicle should be equipped with a connection with travel speed pulse input according to ISO 16844-2.

When connecting the sand spreader to carrier vehicle electrical system (Figure 5.8):

- Connect the leads of the power supply wiring harness (1) equipped with a 3-pin socket (2) to the carrier vehicle's battery (24V). Connect the red lead to the positive end of the vehicle's battery (+) and the black lead to the negative battery end (-).
- The vehicle travelling speed signal should be fed to the contact (4) in the 3-pin socket (2).
- Connect the plug (3) to the socket (2) of the power supply wiring harness (1). Contact (9) of the plug must be connected to the vehicle ground speed signal contact (4).
- Connect the control panel main switch (8) to the

DANGER

Prior to connecting individual system conduits, the user must carefully read the carrier vehicle operator's manual and observe all Manufacturer's recommendations.

IMPORTANT

During operation, the connecting cables should be routed so that they do not get entangled in moving machine and carrier vehicle parts.

connector in the display wiring harness (5)

- Connect the control panel (7) to the wiring harness connector (5).
- Connect the wiring harness of the display (5) terminated with the 10-pin connector to the 10-pin socket (6) of the sand spreader's wiring harness.
- Place the control panel in the operator cab in an easily accessible place.

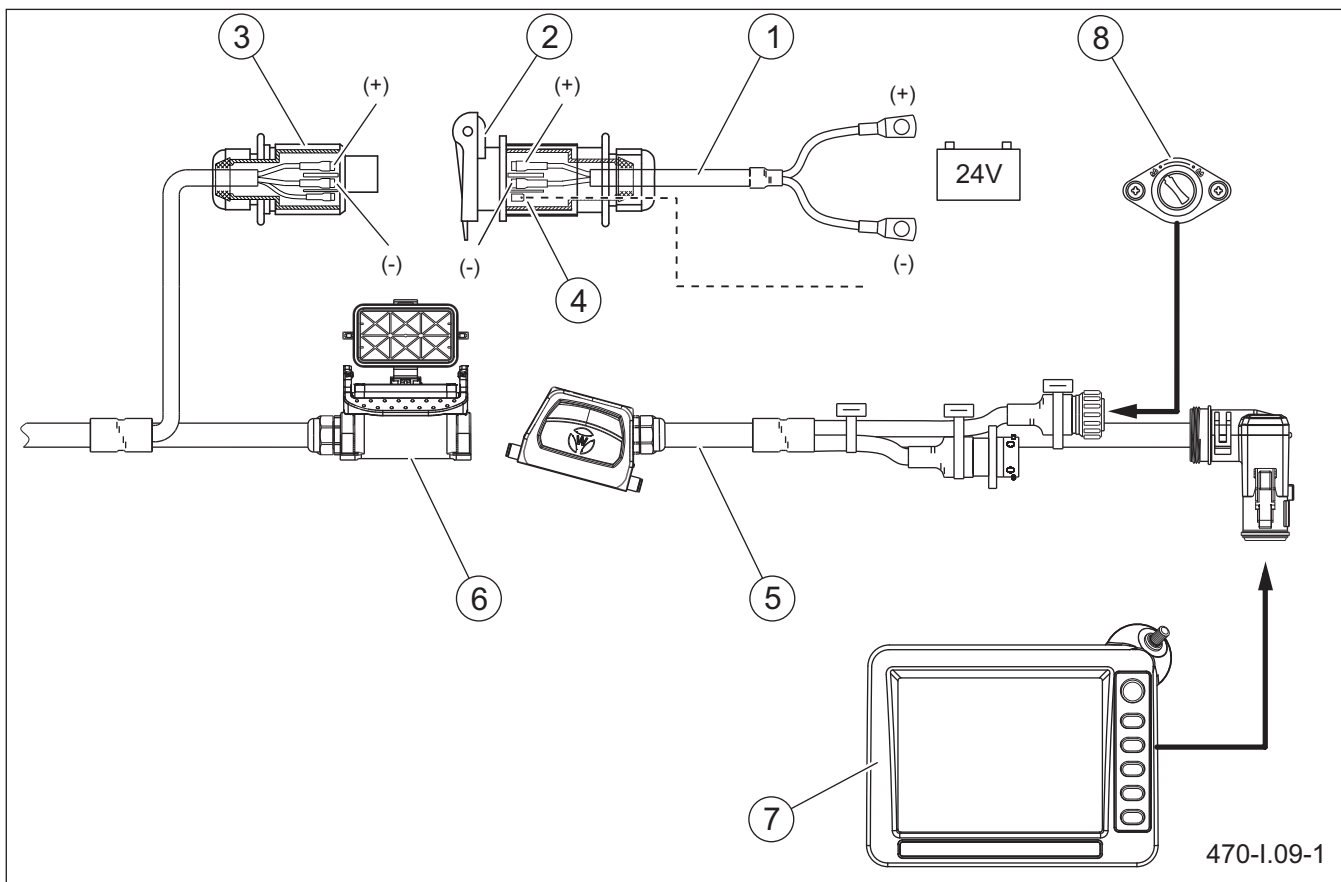

Figure 5.8 Connect the electrical system

(1) electrical power harness (2) 3-pin socket (3) 3-pin plug (4) vehicle ground speed signal (5) control panel harness (6) 10-pin socket (7) control panel (8) control panel main switch (9) 3-pin plug contact

CONNECT THE HYDRAULIC SYSTEM

The sand spreader is designed for connecting with the external hydraulic system of the carrier vehicle.

Connect supply line to hydraulic socket (1) while connect plug (2) to carrying vehicle hydraulic system oil return line (figure 5.9).

**IMPORTANT**

Reduce pressure in the system prior to connecting the machine to the hydraulic system.

TIP

After connecting the spreader, check the oil level in the external hydraulic system of the carrier vehicle.

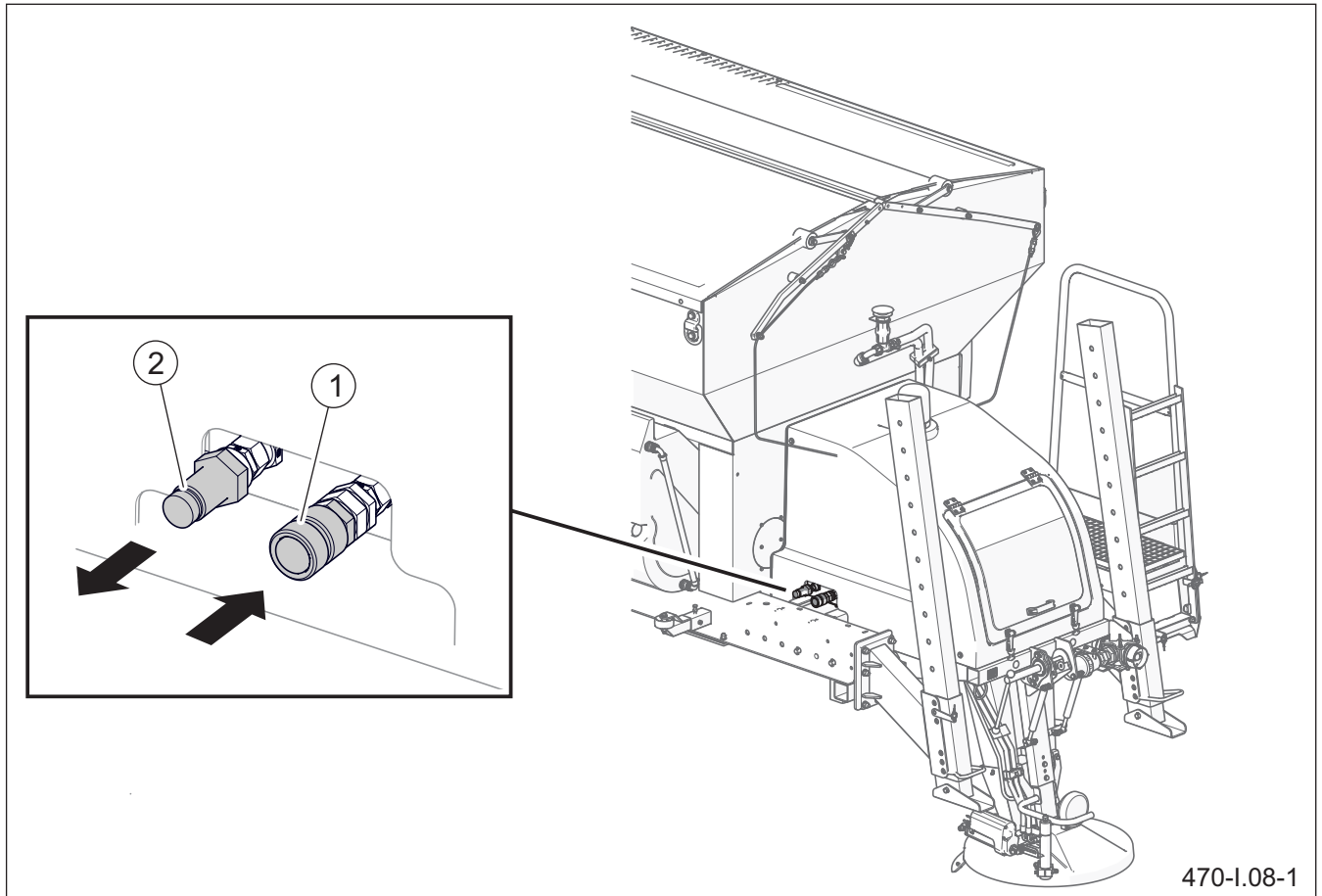

Figure 5.9 Connect the hydraulic system
(1) oil supply socket (2) carrier system oil return plug

I.2.4.470.03.1.EN

5.4 GET READY FOR OPERATION

SET UP THE SPREADING MECHANISM

Before starting work, set the spreading mechanism in a proper manner. Adjustments are made after installing the machine on the carrier vehicle.



DANGER

The spreading mechanism may be lowered, raised and set in any manner only when the machine installed on the carrier vehicle's load box is switched off.

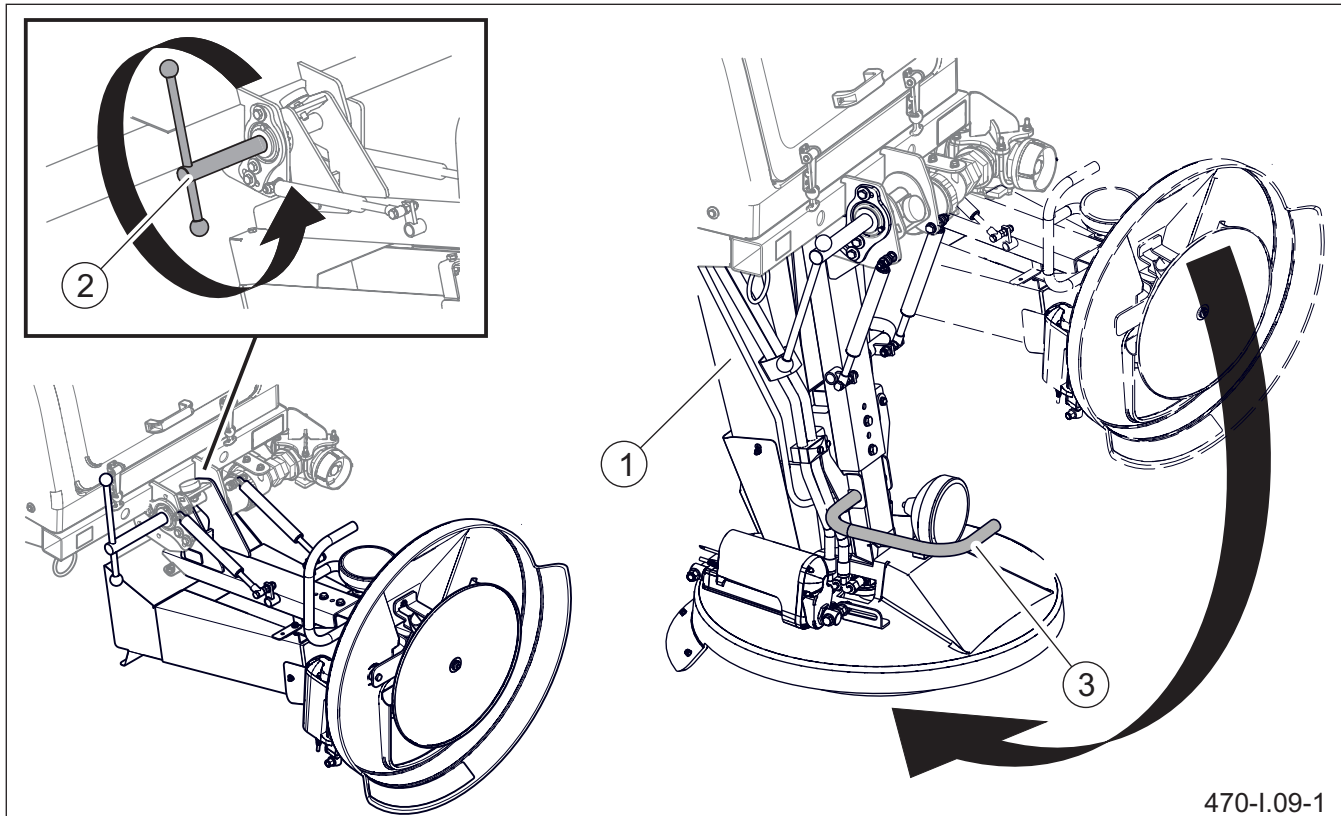

470-I.09-1

Figure 5.10 Lowering the spreading mechanism
(1) spreading mechanism (2) compression bolt (3) bracket

Lower the spreading mechanism (Figure 5.10) to working position:

- loosen clamp bolt (2),
- lower the mechanism while holding grip (3),
- tighten clamp bolt (2).

During operation, the spreading disc should be levelled (Figure 5.11) To check that the spreading disc is level, measure the distances between the disc and the ground in two extreme points (A) to confirm that the distances are the same (Figure 5.11). Otherwise, make adjustment as follows:

- check that clamp bolt (2) is tightened,
- loosen three bolts (1),
- shift the spreading mechanism forwards or

backwards in order to set the spreading disc in such a manner that distances (A) are the same,

- Tighten fixing bolts (1) – (figure 5.11).

After levelling the spreading disc, check its height above the road surface. After lowering of the spreading mechanism, correctly set spreading disc should be located at the height of $400 \pm 15\text{mm}$ above road surface (Figure 5.12).

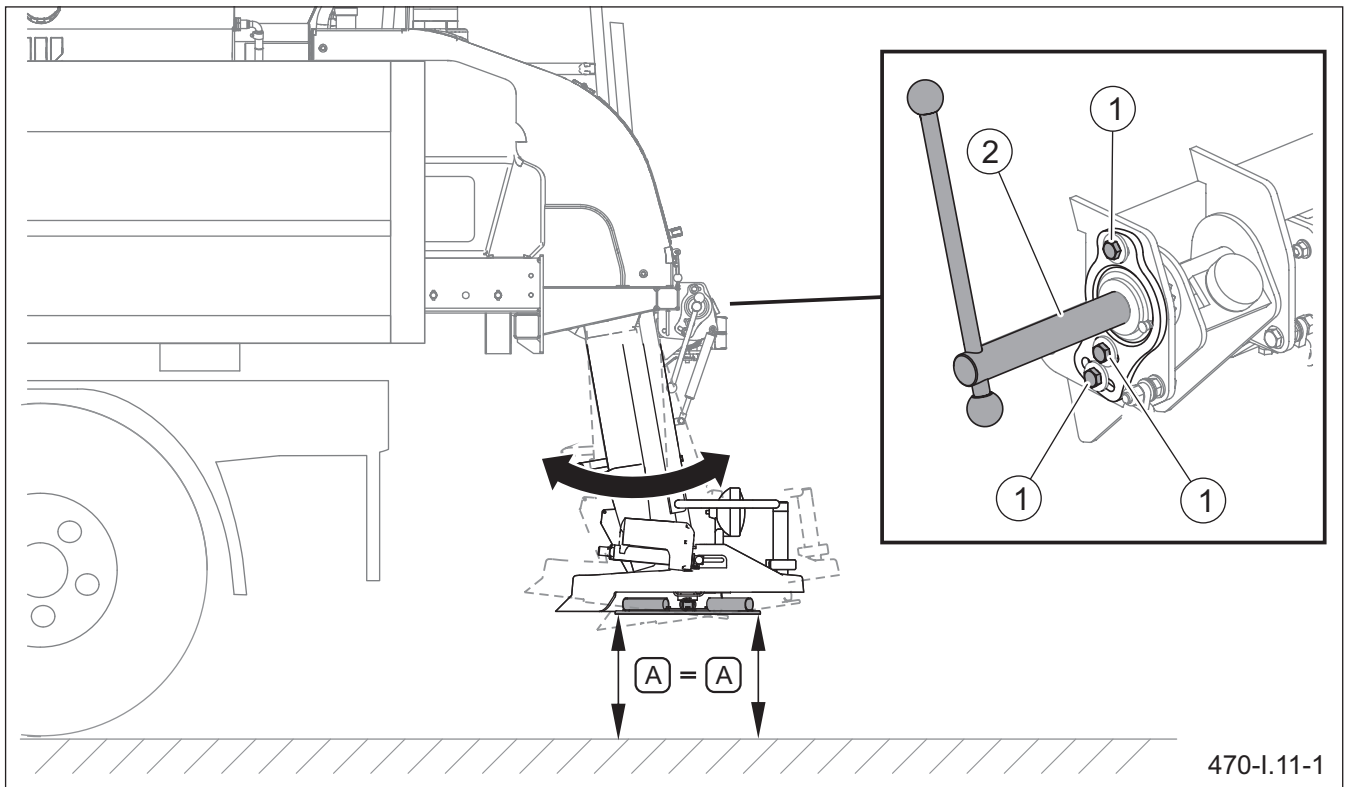

Figure 5.11 Levelling the spreading disc
 (1) bolt (2) compression bolt

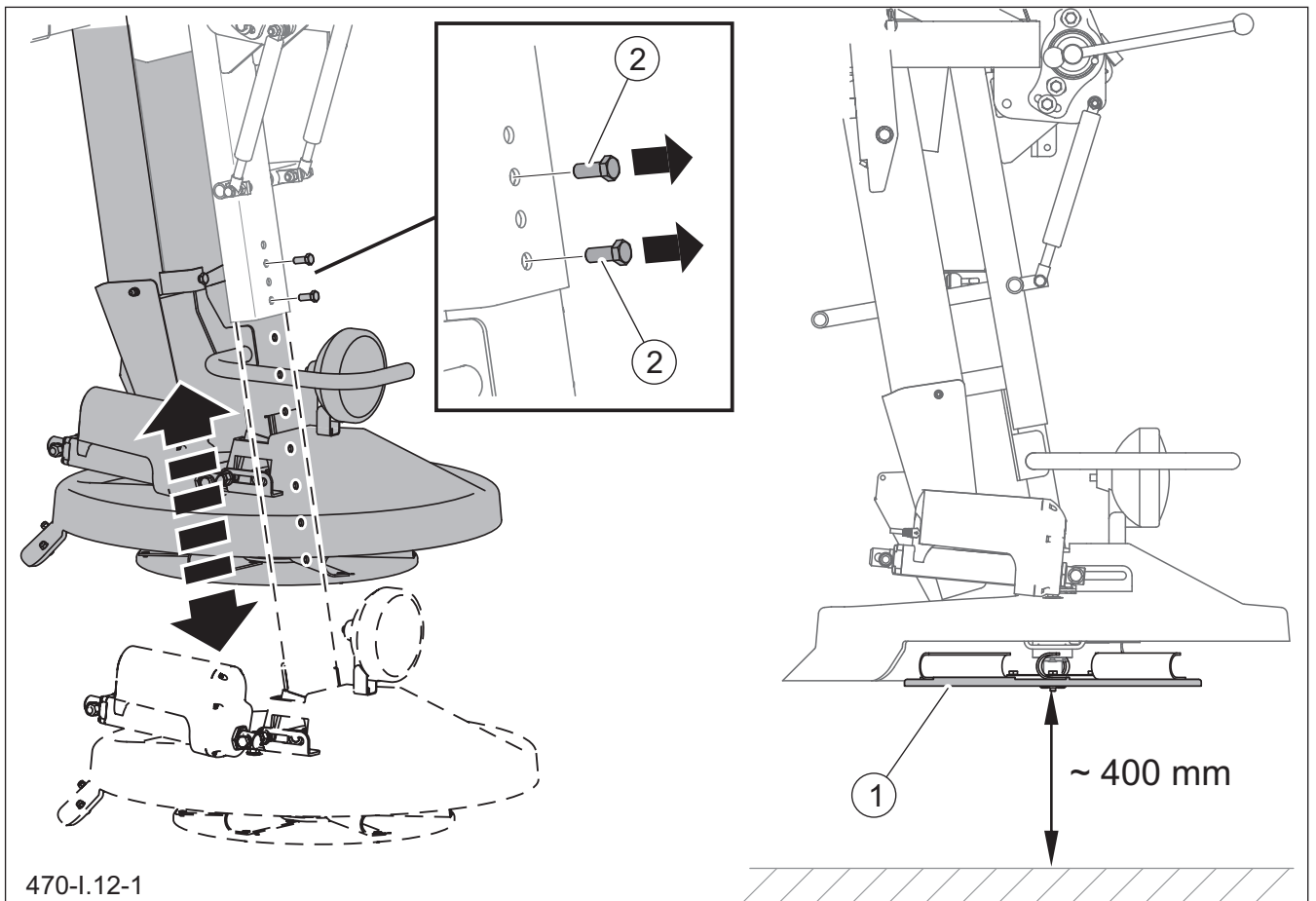

Figure 5.12 Setting the distance between the spreading disc and road surface
 (1) spreading disk (2) bolt

To set the distance between the spreading disc and road surface (Figure 5.12):

- unscrew two bolts (2) while holding the spreading mechanism,
- set the spreading mechanism so as to ensure that the distance between spreading disc (1) and road surface is approximately 400 ± 15 mm,
- screw bolts (2) into proper holes of the guide (Figure 5.12)

The distance between the spreading disc and road surface is recommended to be checked again after loading the tank and filling the tank with brine. Please note that the spreading width depends on the height of spreading disc above the road surface.

SETTING THE BELT CONVEYOR BARRIER

Depending on spreading material, belt conveyor barrier (Figure 5.13) should be set in one of the three positions:

- Position (A) – salt spreading (conveyor barrier opening: 45mm).
- Position (B) – sand spreading (conveyor barrier opening: 125mm).
- Position (C) – tank emptying (conveyor barrier maximally opened).

To change the position of barrier (1), pull and turn handle (2) to a selected position (A), (B) or (C). Position (C) is used only when unloading material from the tank of parked sand spreader (see *UNLOAD*) Proper position of the barrier can be checked by means of slide (3).

I.2.4.470.04.1.EN

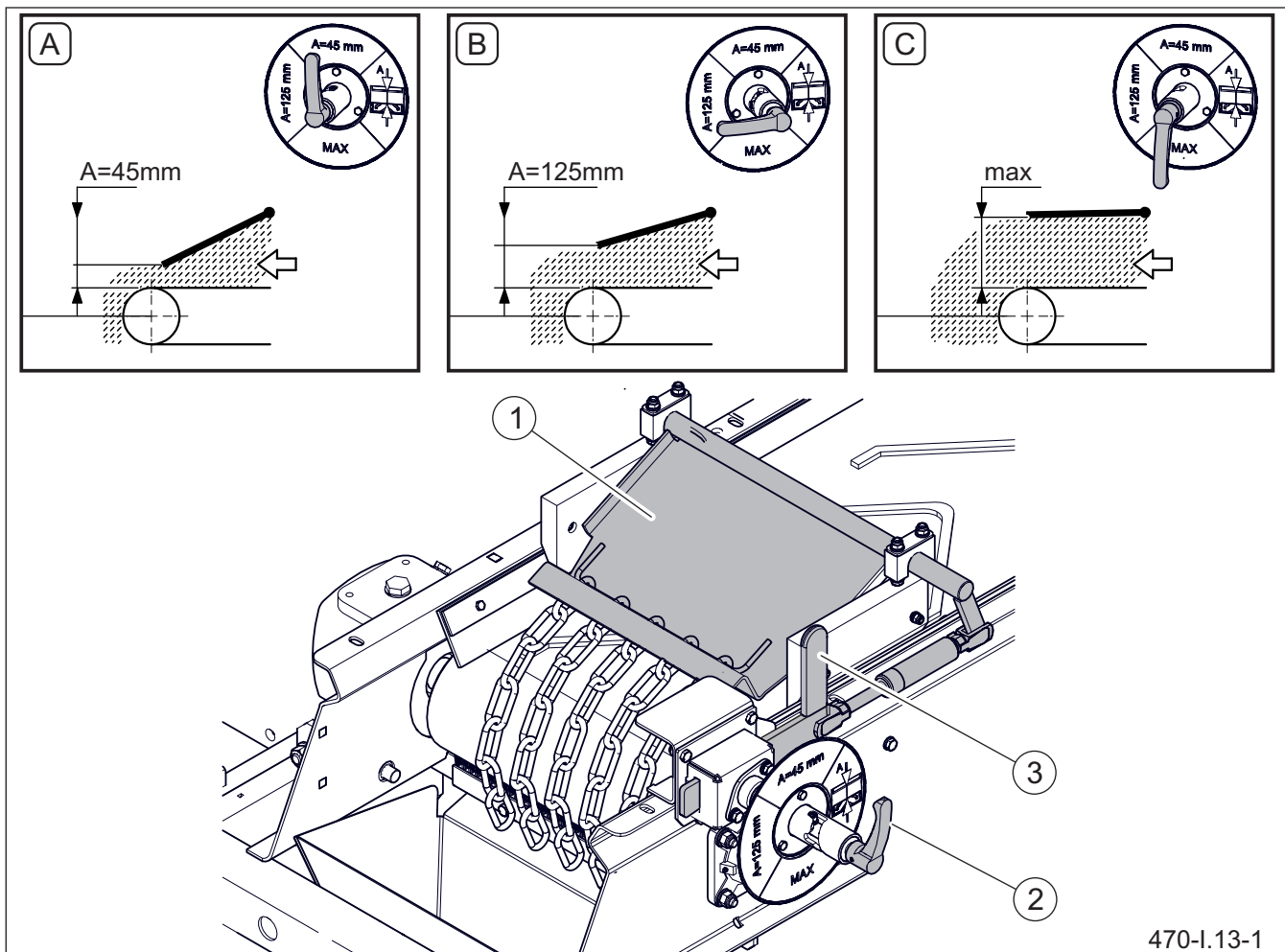

470-I.13-1

Figure 5.13 Setting the belt conveyor barrier
 (A) salt spreading (B) sand spreading (C) emptying the tank
 screen (2) locking pin (3) slider

(1)

5.5 LOAD THE MACHINE

LOADING THE TANK

The platform (2) fitted with ladder (1) (Figure 5.14) facilitates raising and lowering the tarpaulin cover.

To lower the ladder (Figure 5.14):

- hold the ladder (1) and remove securing cotter pin (3),
- lower the ladder (1).

Release pawl (3) by pulling a cord (2) (Figure 5.15) and raise tarpaulin cover by means of frame lever. Tarpaulin cover rising sequence (I) - (II) is shown in (Figure 5.15). Before loading, check that there are no foreign objects (tools, stones etc.) in the tank. The tank should be loaded from above through the sieve that prevents lumps of material from entering the tank. When loading the tank, it is recommended to use a front loader or belt



DANGER

Loading may be performed only if the sand spreader is switched off and mounted on the carrier vehicle's load box. Be especially careful when loading the machine.



IMPORTANT

Spreading agents must be prepared in accordance with the regulations concerning winter road maintenance in force in the country in which the sand spreader is used. Spreading agents other than those recommended by the Manufacturer must not be used.

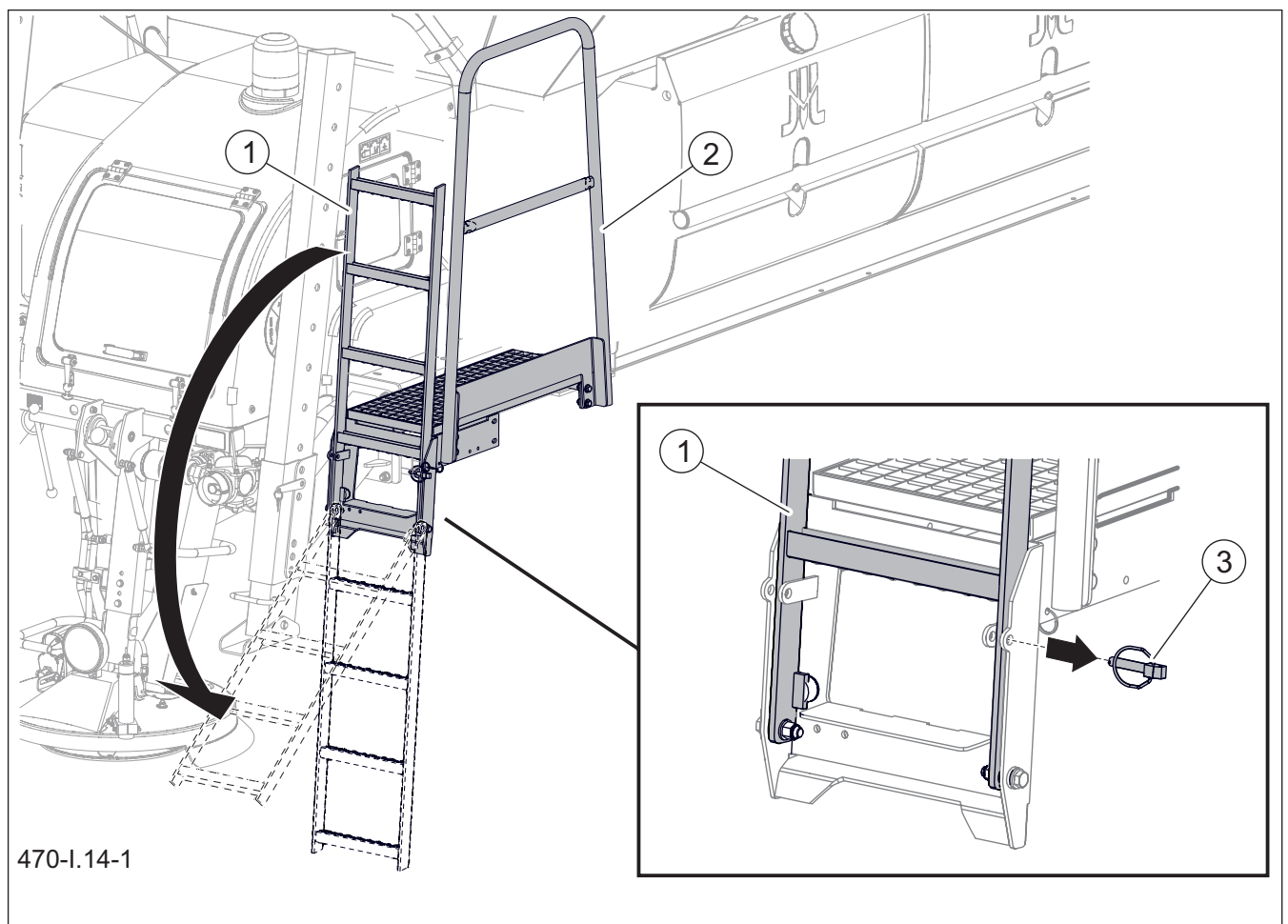

Figure 5.14 Ladder and platform
(1) ladder

(2) platform

(3) securing cotter pin

conveyor. Efforts should be made to evenly distribute the load in the tank in order to ensure proper stability of the sand spreader. Avoid throwing material into the tank from a great height. After loading, cover the tank

with tarpaulin (Figure 5.15) and make sure that the pawl (3) is locked.

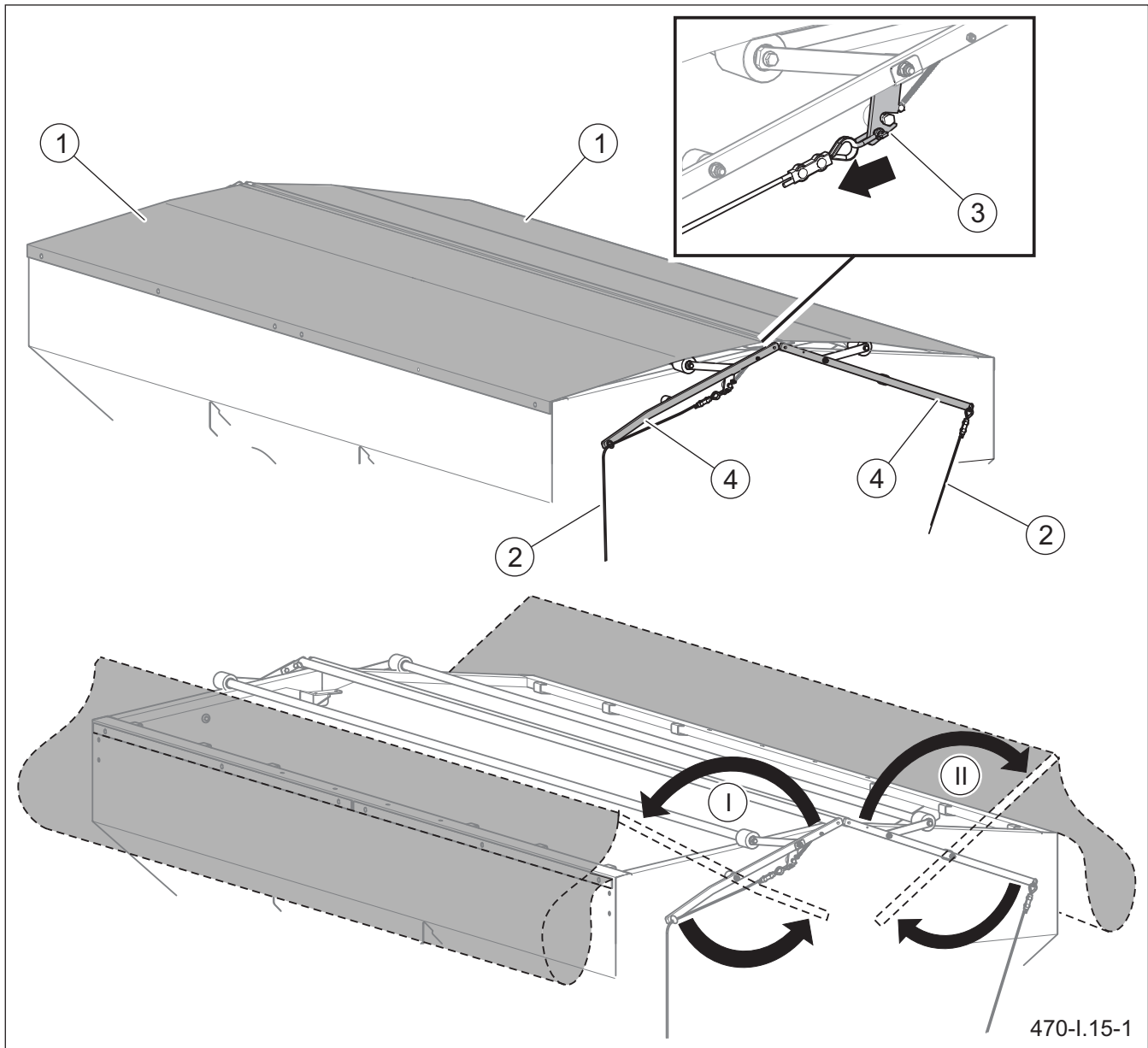

Figure 5.15 Raise the tank tarpaulin cover

(1) tarpaulin cover

(2) pawl cord

(3) latch

(4) lever

(I) (II) opening sequence

470-I.15-1

FILL THE TANK WITH BRINE

The tanks can be filled with brine (Figure 5.16) through tank openings secured with plugs (1) or through connection (2) secured with a plug (3).

In order to fill the tanks with brine (Figure 5.17) through connection (2):

- set valve lever (4) in position (B),
- unscrew plug (3) and connect filling hose to connection (2),
- set valve lever (4) in position (A) and start filling,

! DANGER

Filling the tanks with brine should be performed only if the sand spreader is switched off and mounted on the carrier vehicle's load box. Be especially careful when filling the tanks.

TIP

Each time before filling the tanks with brine, check and, if necessary, tighten the bolts fixing the tanks to the frame.

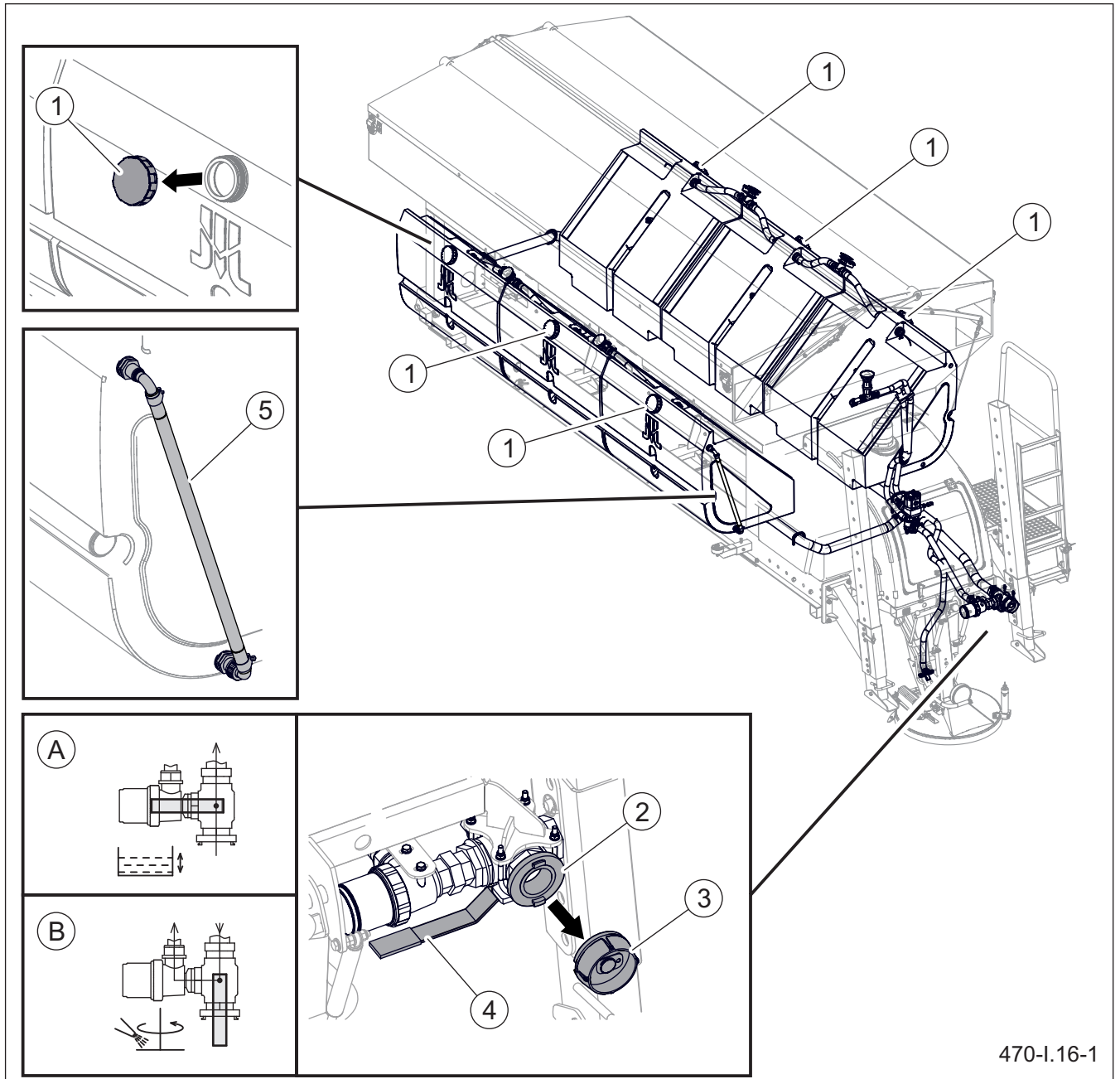

470-I.16-1

Figure 5.16 Fill the tank with brine

(1) tank plug

(4) valve lever

(B) valve in "brine spray" position

(2) STORZ 52C connector

(5) brine level indicator

(3) valve plug

(A) valve in the "filling / drain" position

- brine level is checked on brine level indicator (5) located on the tank,
- when filling is completed, set lever (4) to position (B),
- disconnect filling hose and tighten plug (3).

To fill the tanks directly through filler opening, unscrew plug (1) and insert filling hose to filler opening. It is enough to fill one tank only, because all tanks are connected. When filling is completed, tighten the tank plug.

TIP

If filling with brine is performed too quickly, the tank to which brine is poured directly may be filled faster than the other tanks. In such a case, stop filling and wait until level of liquid in all tanks is the same.

I.2.4.470.05.1.EN

5.6 MACHINE OPERATION

PRELIMINARY INFORMATION

Proper starting of the sand spreader includes a range of preparatory activities such as:

- daily inspection,
- Machine setup
- preparing for work and loading,
- Start hydraulic system
- starting proper working.

If no contraindications for starting the sand spreader are found, commence starting the machine.

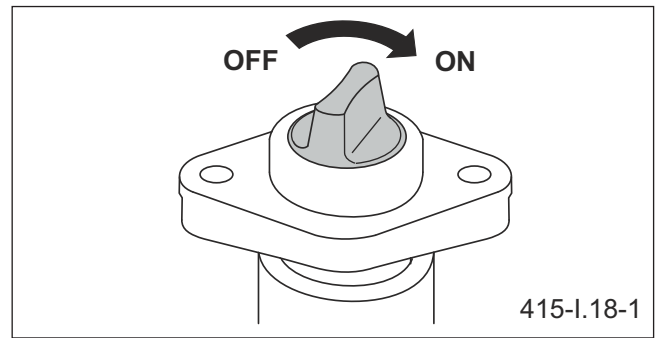

Figure 5.17 Main switch of control panel (ON) turned on (OFF) turned off

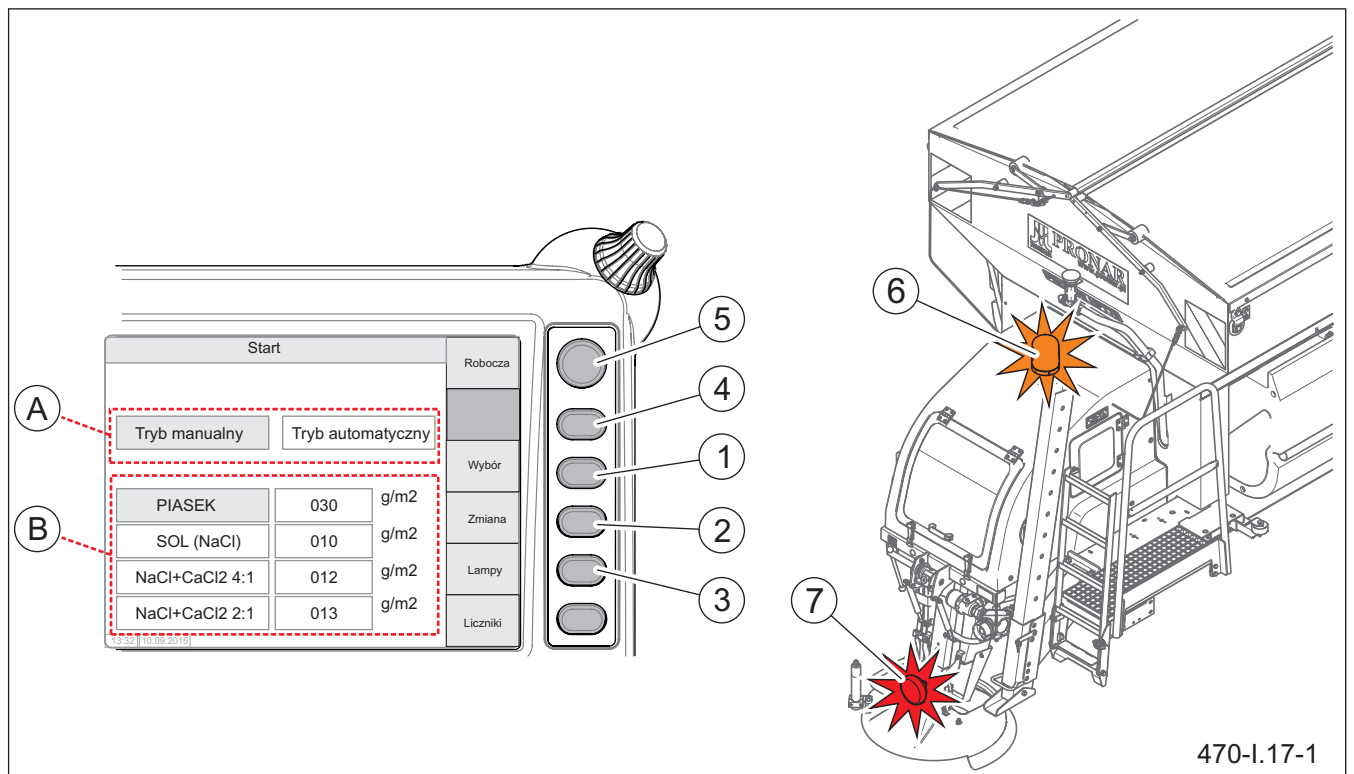



Figure 5.18 Activate individual functions on control panel home page (A) operating mode check box (B) material selection check box (1)-(5) function buttons (6) beacon light (7) rear lamp

START SPREADING

- Turn control panel on.
Turn main switch (Figure 5.17) clockwise to (ON) position - switched on (the switch is installed on the control panel power lead).
- Mark mode selection field (A) on "START" home page of the control panel (Figure 5.18) by means of the "Select" button (1). Press the "Change" button (2) to select "Manual mode" (if automatic

 **DANGER**

Do NOT use a malfunctioning or incomplete machine.

 **IMPORTANT**

Do NOT start the machine without making certain that it is in perfect technical condition.

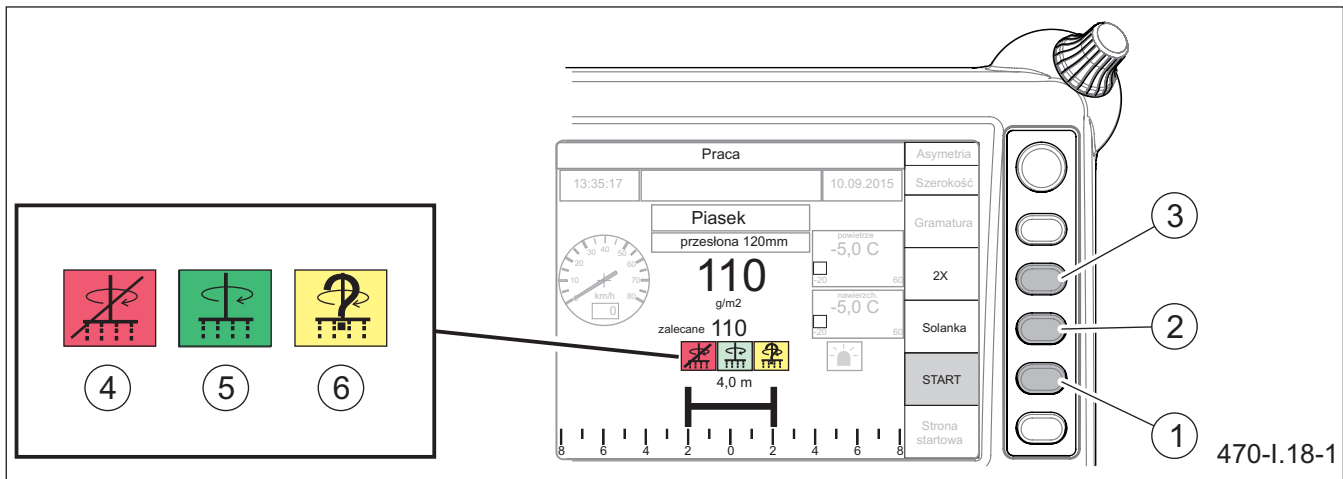

Figure 5.19 Start spreading
 (1) spreading on button
 (4-6) spreading status indicators

(2) activate brine spray button

(3) double dose button

mode is active).

- Move to field (B) by means of push-button (1) „Selection” and select the type of material to be spread. By means of „Change” push-button, select the type of material to be spread that is currently in the tank.
- Press the button (3), turn on warning lamp (6) at the rear of the machine and lamp (7) near the spreading disc.
- On control panel “Operation” page (Figure 5.19), press button (1) to activate spreading; the “Start” function will be highlighted.

Activation of spreading disc drive and belt conveyor is indicated by light (5) on the

IMPORTANT

The optical sensor detects 3 conditions: spreading - green indicator light, no spreading - red indicator light, clogged sensor - yellow indicator light and green indicator light are ON simultaneously.

DANGER

There must be no bystanders within the sand spreader working zone.

control panel (Figure 5.19). Brine spraying is switched on and off by means of push-button (2) “Brine” (not active for sand).

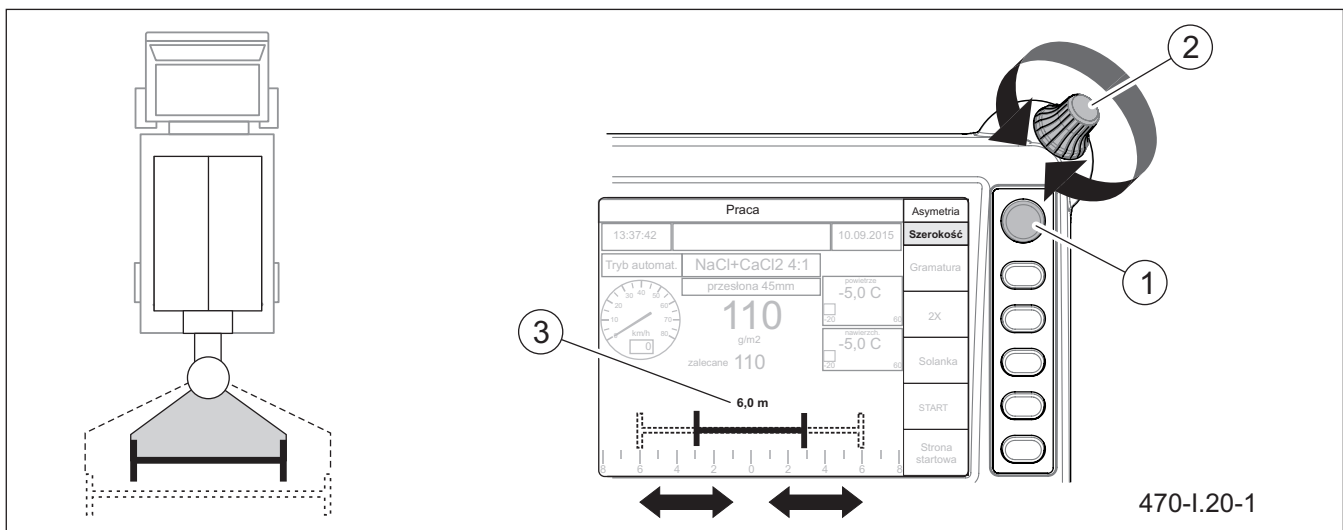

Figure 5.20 Adjustment of spreading width

(1) “Asymmetry-Width” selection button

(2) parameter adjust knob

(3) current spreading width

Push button (3), marked "2X" to temporarily double the spreading material dose.

Spreading can be started before moving off or during travel. Adjust travelling speed to road conditions and spreading material:

- travelling speed during sand spreading: 10 – 40 km/h,
- travelling speed during salt spreading: 10 – 70 km/h.

CHANGE SPREADING WIDTH AND ASYMMETRY

Spreading width is changed from the operator cab, on control panel working page ("OPERATION"). To change spreading width (Figure 5.20):

- highlight "Width" function by means of push-button (1),
- turn knob (2) to set a required width (3) from 2 m ÷ 12 m.

To change asymmetry of spreading, highlight "Asymmetry" field on working page "Operation" by means of push-button (1). Turn knob (2) to move current spreading width to the right or to the left (Figure 5.21). For example, in the figure 5.22, for spreading width of 6 m, spreading asymmetry is shifted to the right.

ADJUSTMENT OF SPREADING MECHANISM

If there are differences in spreading symmetry during spreading mechanism operation, with regard to values set on the control panel, it may be necessary to adjust

the setting of the electric cylinder.

In order to adjust the spreading mechanism (Figure 5.22), set symmetric 4 meter-wide spreading zone on the control panel. Activate spreading and drive a short distance at a constant speed. Stop the vehicle and check effect of spreading. If spreading to the right side and to the left side is not the same, adjust spreading direction (Figure 5.22) adjusting cylinder (1) as follows:

- Loosen nut (2).
- Move cylinder (1) forwards if spreading zone is excessively shifted to the left (A).
- Move cylinder (1) backwards if spreading zone is excessively shifted to the right (B).
- Tighten nut (2), conduct test spreading, if necessary, repeat the adjustment.

OPERATION IN AUTOMATIC MODE (OPTION)

Optionally, the sand spreader can operate in automatic working mode. In automatic working mode, the electronic system selects a proper dose of material on the basis of road surface temperature measurement and selected, defined working mode. Three working modes are defined in the automatic working mode according to the guidelines for winter road maintenance issued by the General Directorate of Domestic Roads and Motorways:

- T1 – prevent formation of black ice, glazed frost, hoarfrost,
- T2 – prevent snow freezing to road surface,
- T3 – eliminate black ice, hoarfrost, thin layers of

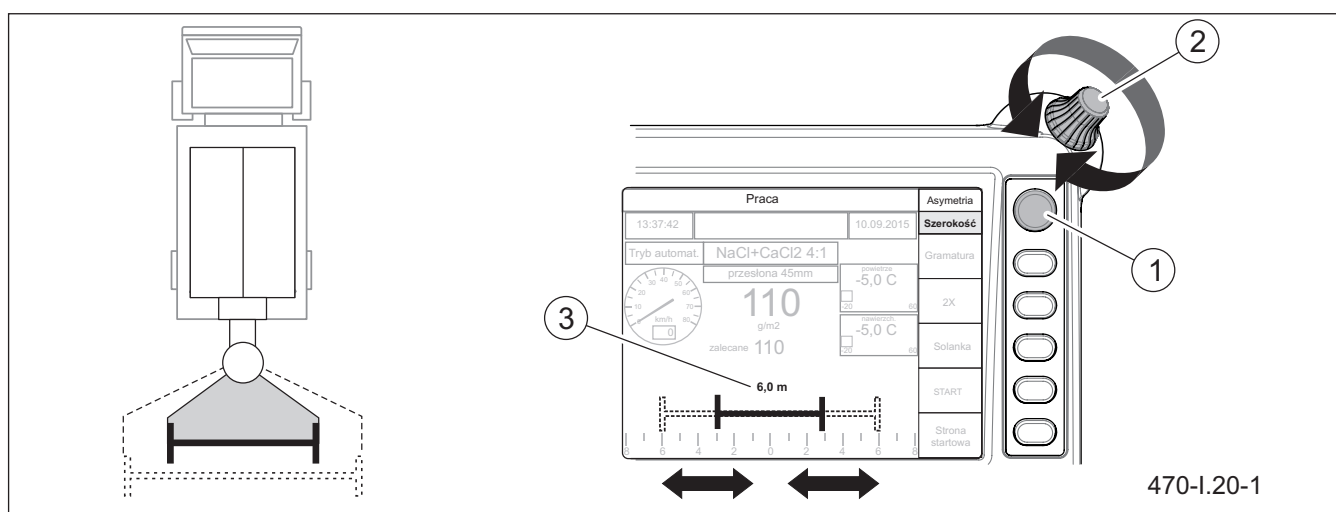

Figure 5.21 Changing asymmetry of spreading

(1) "Asymmetry-Width" selection button

(2) parameter adjust knob

(3) image of spreading asymmetry

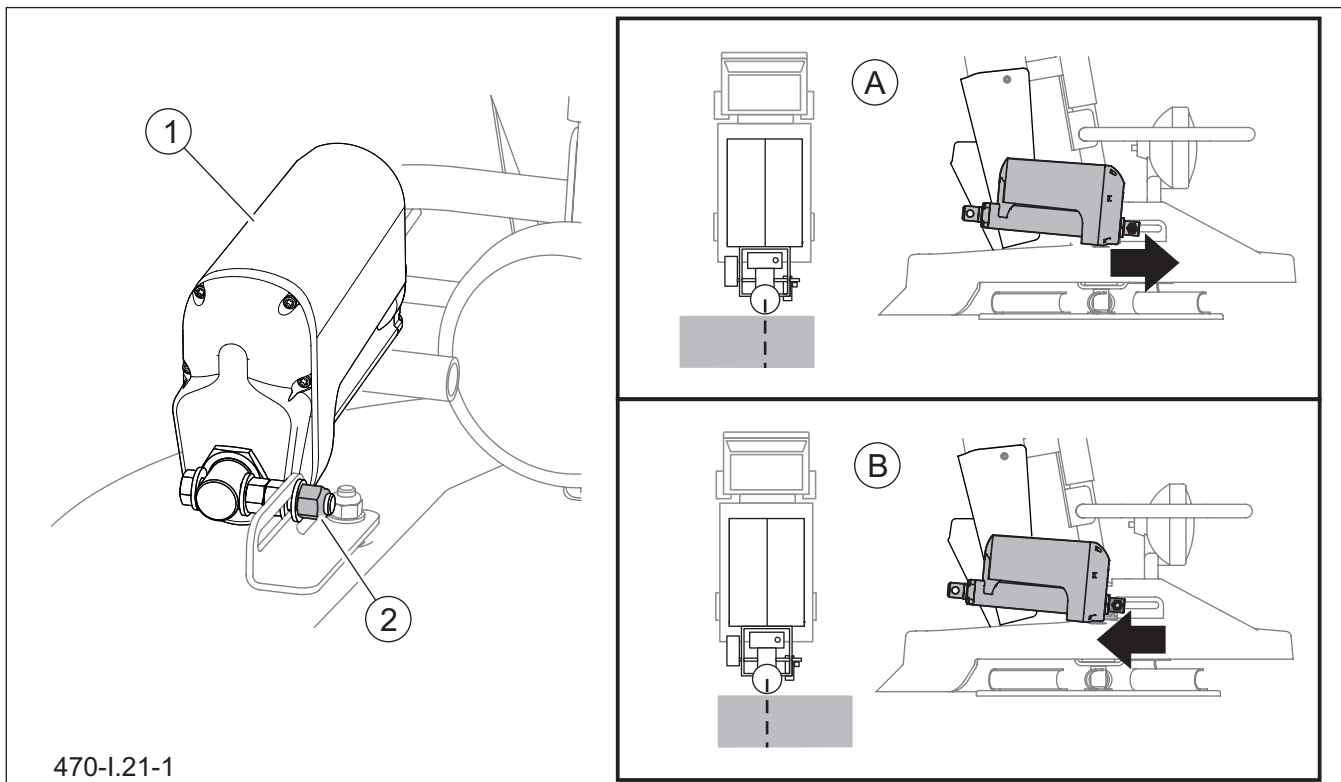

Figure 5.22 Adjustment of spreading mechanism
 (1) spreading direction adjustment cylinder (2) nut (A) spread shifted too far to the left
 (B) spread shifted too far to the right

compacted or icy snow, remains of fresh snow.

To select automatic mode (option):

- on the "Start" home page of the control panel (Figure 5.23), use button (1) to check the box (A) for selecting the operating mode,
- select "Automatic mode" by means of push-button

(2) "Change",

- select one of the three defined modes T1, T2, T3 by means of push-button (1) "Selection",
- by means of push-button (1), mark field (C) and then, by means of push-button (2) „Change”, select (C) type of material to be spread that is

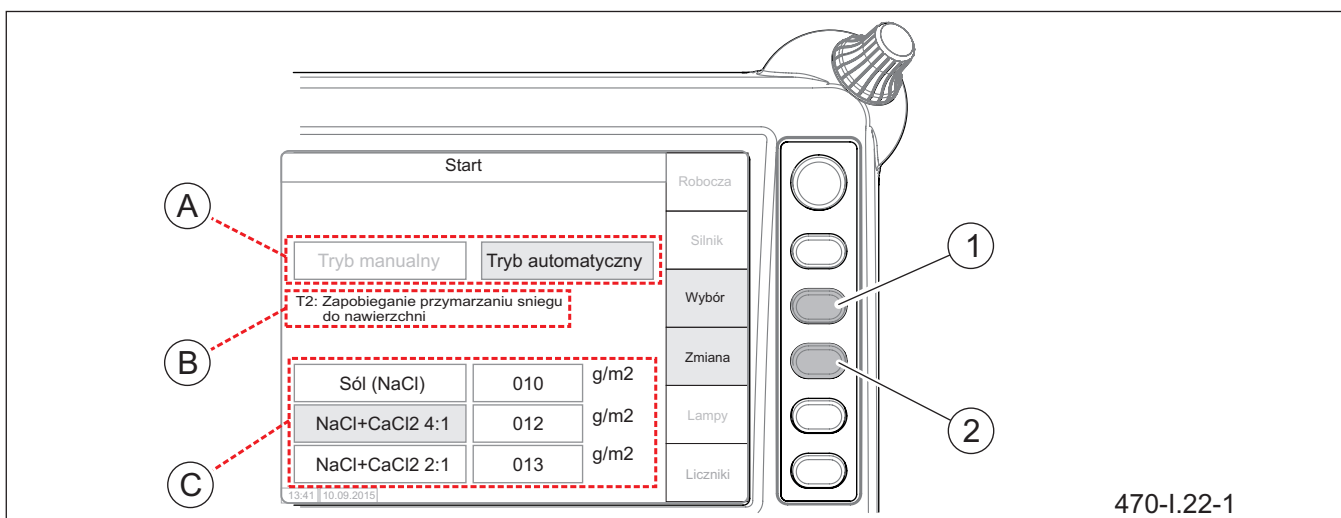

Figure 5.23 Select automatic mode
 (1) button to select field A, B or C for editing (2) button to change the selected field (A) automatic/manual mode (B) automatic mode type T1, T2, T3 check box (C) spreading material check box

currently in the tank (automatic mode can not be selected for „Sand”).

On control panel "Operation" page (Figure 5.24) the operator can correct the dose for a defined automatic mode after selecting "Spreading density" function by pushing button (1). Correction is made by means of knob (5). Recommended density (3) for a defined mode T1, T2 or T3 is displayed below spreading density set by the operator (2).

STOPPING OF SPREADING

- On control panel "Operation" page push button (1) to turn off spreading.
Indicator light (3) will go out when the spreading disc drive and the belt conveyor are stopped.
- Next push button (2) to go to "Start" home page and turn off the lights.

TIP

When road surface temperature change is detected in automatic working mode, the electronic system will change preset spreading density while maintaining the value added or subtracted previously by the operator.
If spreading density is not corrected by the operator in automatic mode, the preset value and recommended value will be equal.

- Turn off the external hydraulic system of the carrying vehicle
- Turn off the control panel power.

Turn the main switch to the (OFF) position - off .

Table 5.1. Examples of specific weights of spreading materials

Solid material		
Material name	Specific weight [kg/l]	Weight per m³[kg]
Medium sand	1.60	1,600
Coarse sand	1.60	1,600
Fine salt (NaCl)	1.20	1,200
Coarse salt (NaCl)	1.32	1,320
Liquid		
Material name	Specific weight [kg/l]	Weight per 1000L [kg]
Calcium solution (CaCl ₂)	1.16	1,160
Saline solution (NaCl)	1.20	1,200

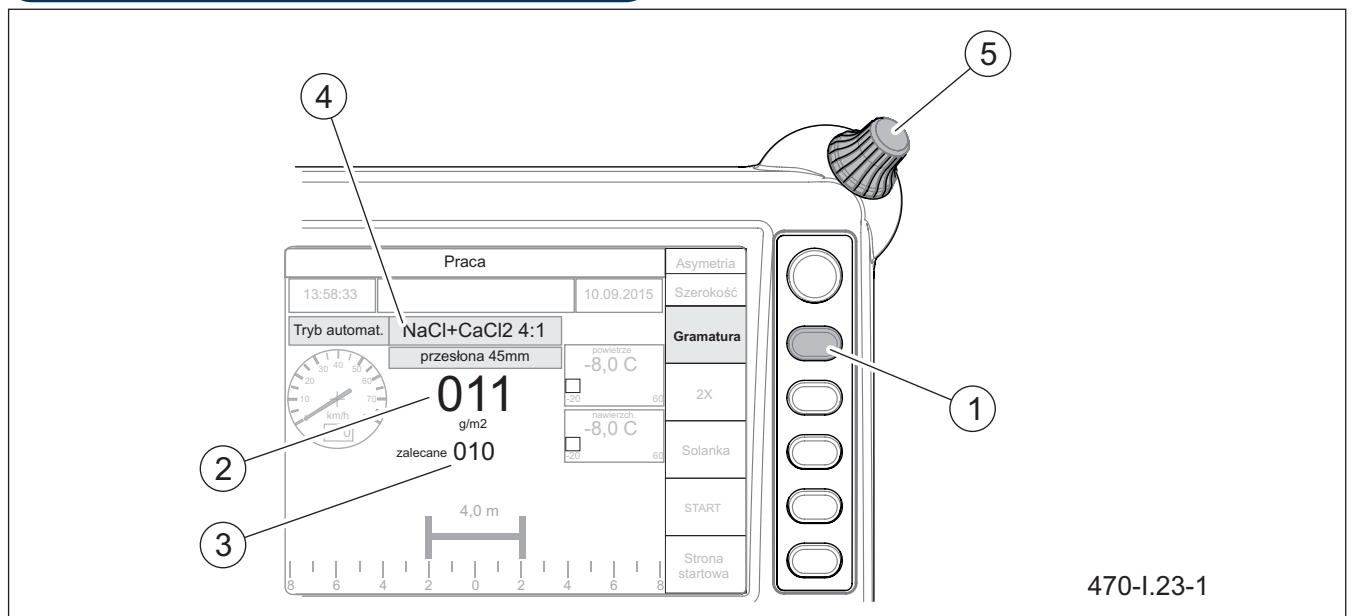

Figure 5.24 Automatic mode adjustment (option)
 (1) adjust dose button (2) setting entered by the operator (3) recommended value (4) previously selected material and operating mode (5) parameter adjust knob

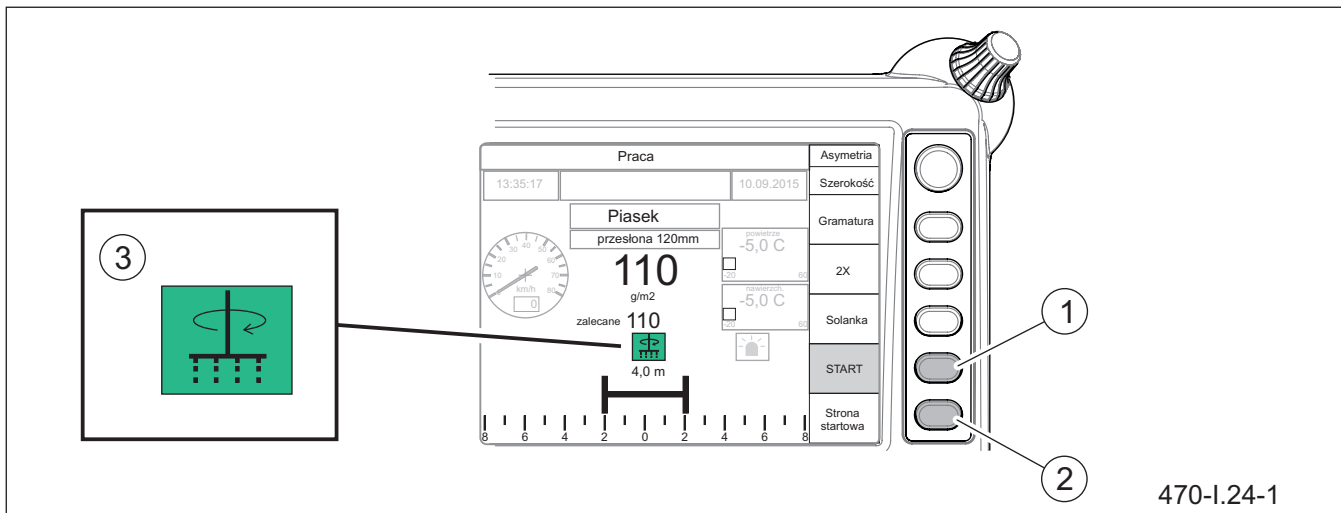

Figure 5.25 Stopping of spreading

(1) spreading on / off button (2) back to home page

(3) spreading activated indicator light

TIP

Doses of material for particular temperature ranges and working modes are defined in table included in the guidelines for winter road maintenance issued by the General Directorate of Domestic Roads and Motorways (Attachment to Ordinance No. 18 of General Director of Domestic Roads and Motorways of 30 June 2006).

I.2.4.470.06.1.EN

5.7 DRIVING ON PUBLIC ROADS

When driving on public roads, respect the road traffic regulations, exercise caution and prudence. Make sure that the machine is correctly attached to the carrier vehicle. During operation, ensure that there is suitable visibility, turn on the orange beacon light at the rear of the machine. Special attention should be paid to the bystanders likely to be near the working machine.

Avoid ruts, depressions, ditches or driving on roadside slopes. Driving across such obstacles could cause the carrier vehicle and the machine to suddenly tilt. Driving near ditches or canals is dangerous as there is a risk of the slope collapsing. Speed must be sufficiently

reduced before making a turn or driving on an uneven road or a slope. For the period of sand spreader operation, protect the lifting system of the carrier vehicle's load box (if any) against automatic or accidental activation.



DANGER

During spreading, adjust travelling speed to the prevailing road conditions and do not exceed the following values:
travelling speed during sand spreading: 10 – 40 km/h,
travelling speed during salt spreading: 10 – 70 km/h.

I.2.4.415.07.1.EN

5.8 UNLOADING

EMPTYING THE TANK

Before dismantling the sand spreader from the carrier vehicle's load box, before adjusting works, repairs and in case of spreading material change, the machine's tank should be completely emptied. In order to do this:

- raise the spreading unit and lock it in the upper position (Figure 5.26),

- set the belt conveyor barrier to maximally open position (Figure 5.27),
- start hydraulic drive.
- on control panel "Counters" page, select "Unload" function,

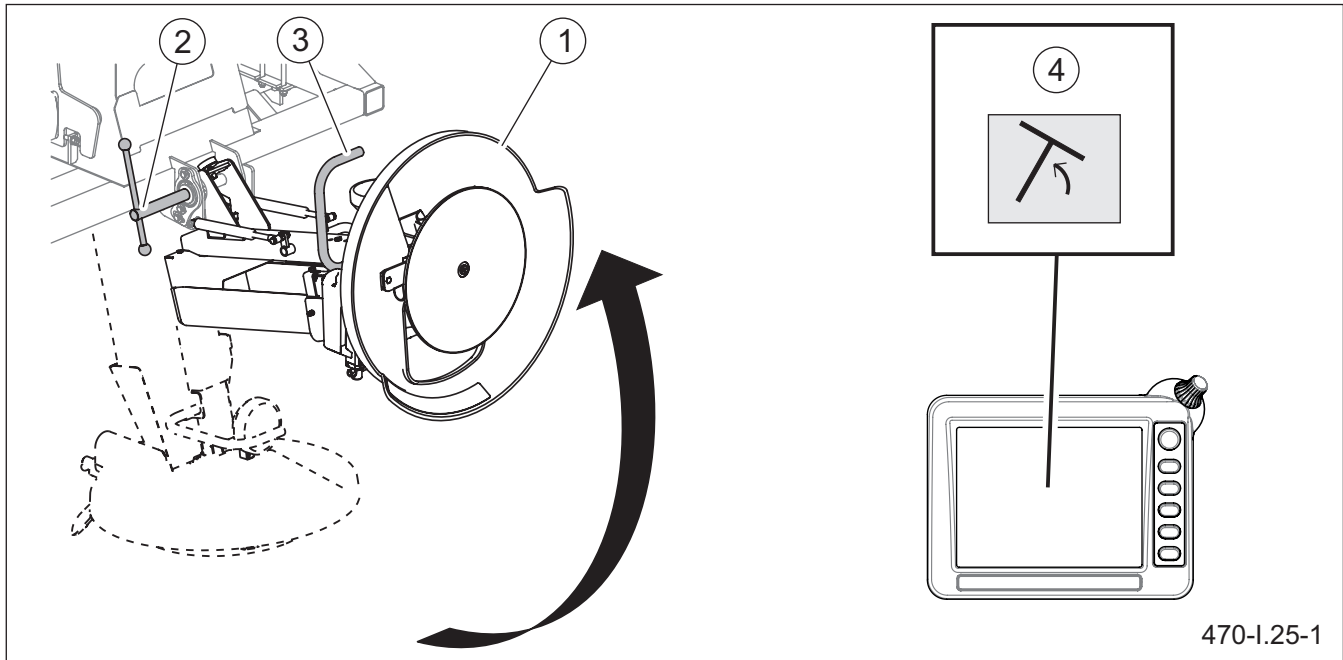

Figure 5.26 Raising the spreading mechanism
 (1) spreading mechanism (2) compression bolt (3) bracket (4) "raised disc" indicator

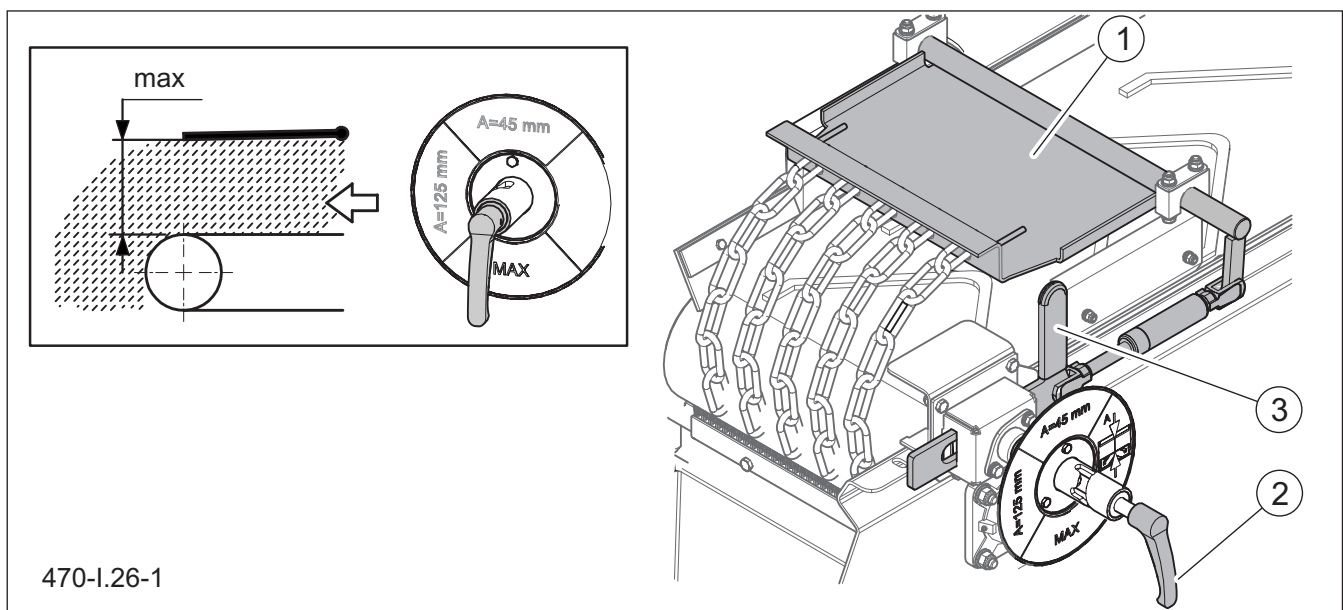

Figure 5.27 Setting the belt conveyor barrier for unloading
 (1) screen (2) locking pin (3) slider

To raise the spreading mechanism for unloading (Figure 5.27) do the following:

- loosen clamp bolt (2),
- raise spreading mechanism (1) while holding grip (3), this will be indicated by the “Raised disc” indicator light on the control panel
- tighten clamp bolt (2).

To adjust the barrier (1) for unloading (Figure 5.27), turn and pull the bolt (2). The barrier is set to maximally open position only when material is being unloaded from the tank.

When the tank is empty, turn off the “Unload” function on the control panel. Lower the spreading system to working position and set belt conveyor barrier to proper position.

EMPTY BRINE TANKS

Before dismantling the sand spreader from the carrier vehicle's load box and before repairs of spray system, empty the brine tanks.

To empty the brine tanks proceed as follows (Figure 5.28):

- prepare a container for brine,
- set valve lever (1) in position (B),
- unscrew plug (2) and connect proper drain hose to connection (3),
- set valve lever (1) to position (A) and start emptying the tanks,
- brine level is checked on brine level indicator (4) located on the tank,
- after emptying the tanks, set lever (1) to position

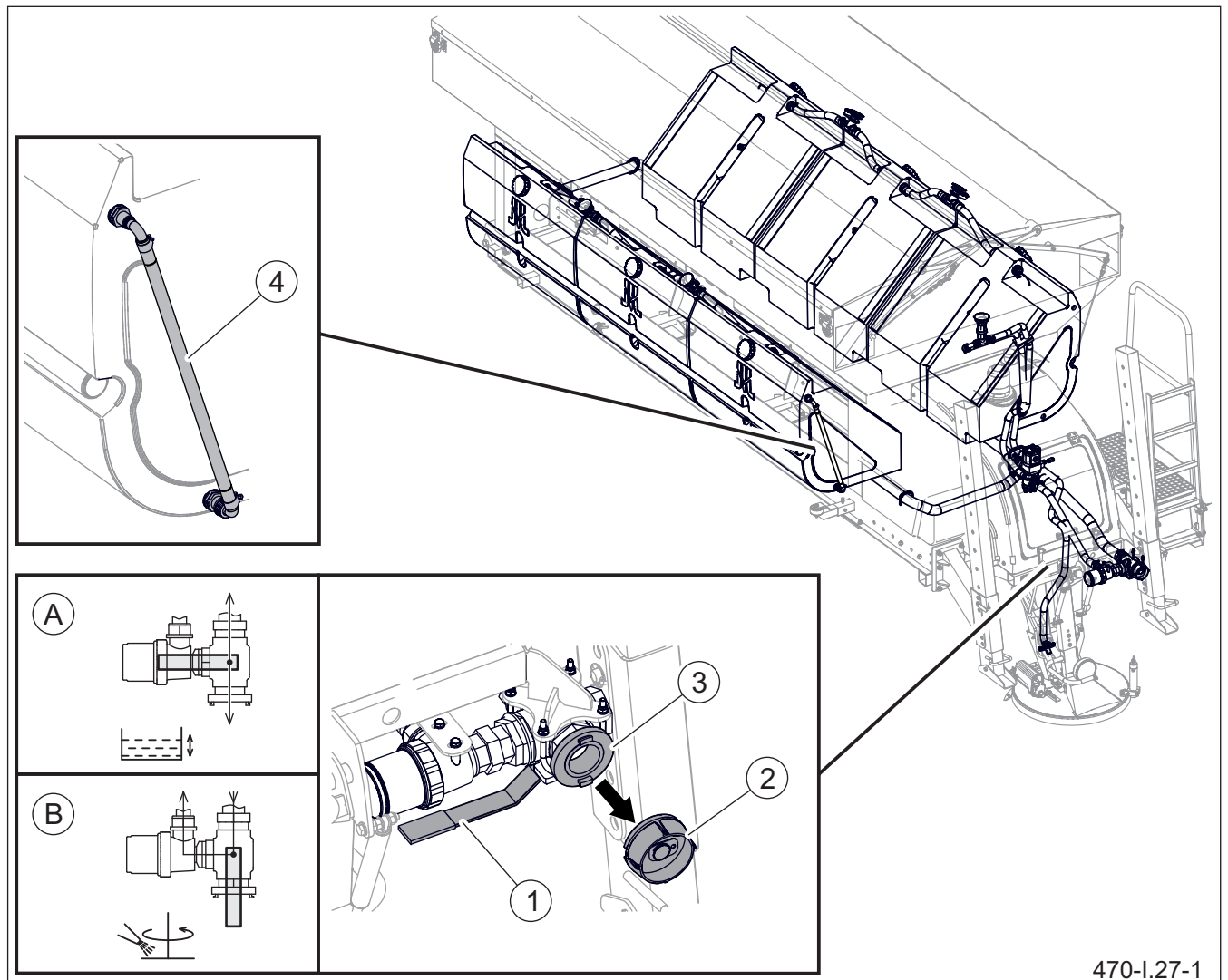

470-I.27-1

Figure 5.28 Empty brine tanks
 (1) valve lever (2) valve plug (3) STORZ 52C valve connector (4) brine level indicator
 (A) valve in the “filling / drain” position (B) valve in “brine spray” position

- (B),
- disconnect drain hose from connection (3) and tighten drain plug (2).

**IMPORTANT**

Before unscrewing plug (2), make sure that valve lever (1) is in position (B) (Figure 5.28).

**DANGER**

Before leaving the cab turn off the carrier vehicle engine, engage the parking brake and secure the vehicle's cab against access of unauthorised individuals.
Exercise caution while unloading.

I.2.4.415.08.1.EN

5.9 REMOVE THE MACHINE FROM THE CARRIER VEHICLE

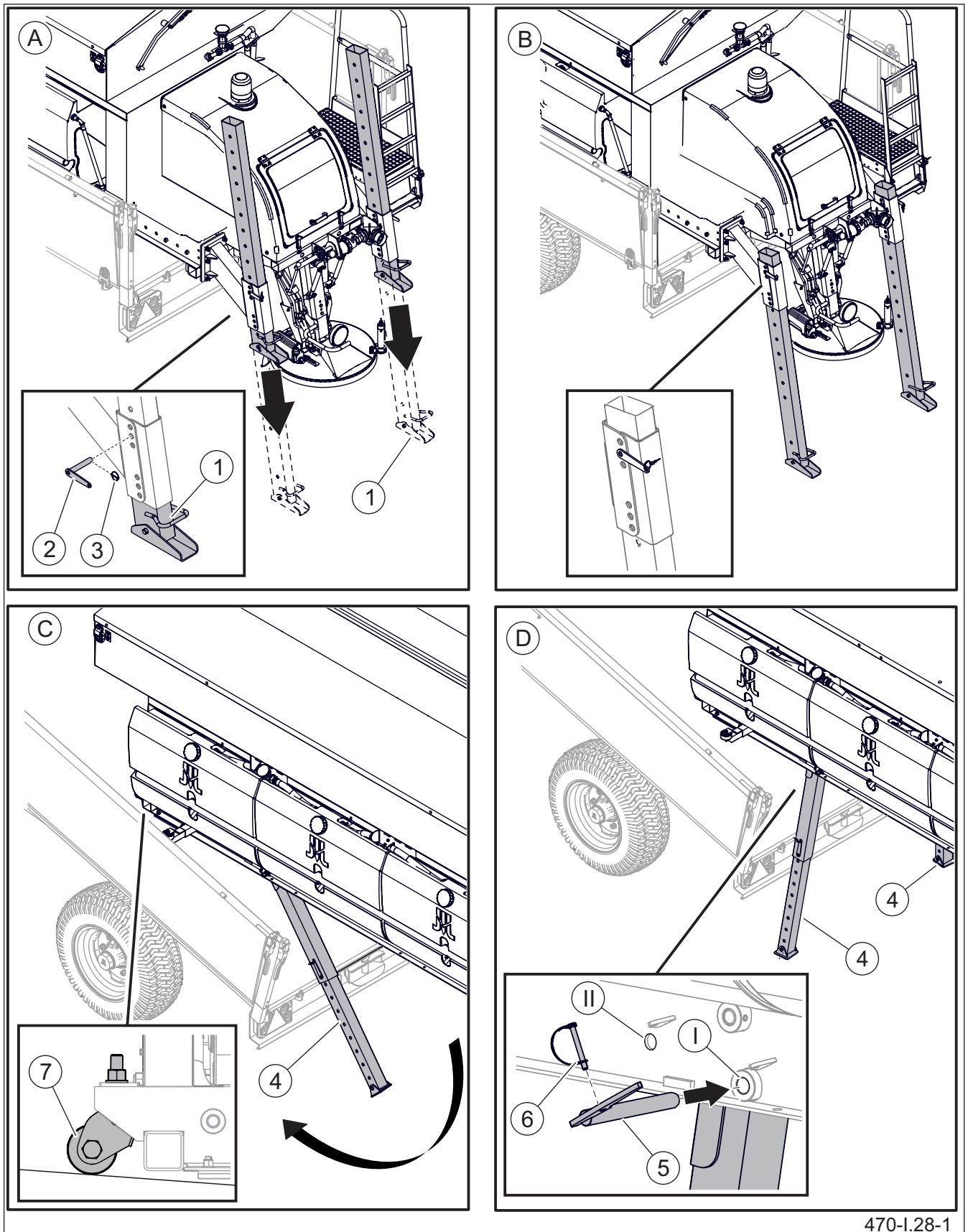

470-I.28-1

Figure 5.29 Installing the parking stands
 (1) rear support (2) rear support pic (3) cotter pin (4) front support (5) front support lock pin
 (6) cotter pin (7) roller

**DANGER**

Before dismantling the machine from the carrier vehicle's load box, turn off the vehicle's engine, engage the parking brake and secure the vehicle's cab against access of third persons. Exercise due caution when dismantling the machine.

**DANGER**

Located at the bottom of the machine, the belt sling terminated with a hook is used to prevent the machine from sliding off the platform during unloading. Be especially careful when hitching and unhitching the hook from the carrier vehicle's element.

Machine removed from the carrier vehicle must be placed on parking stands, on level, sufficiently hard surface in such a manner as to ensure that it is possible to connect it again.

To dismantle the machine from the carrier vehicle's load box proceed as follows:

- Place the carrier vehicle's load box in the area where the machine is to be stored.
- Disconnect control panel and electric leads.
- Remove straps fastening the machine to the carrier vehicle's load box.
- Unlock cotter pins (3), remove pins (2), lower the rear parking stands (1) so that they touch the ground and secure them again in a selected position (A, B – Figure 5.29).
- Carefully raise the load box of the carrier vehicle to such a height as to ensure that rollers (7) at the front of the machine are supported on the platform floor.
- Drive the carrier vehicle with the raised platform forward until the front parking stands (4) unfold

**IMPORTANT**

Before dismantling the machine from the carrier vehicle's load box, the spreading material tank and the brine tanks should be emptied completely.

automatically and stop the vehicle.

- Lock the parking stands (4) by relocating the pins on both sides of the machine from hole (II) to hole (I). If necessary, adjust the height of the front parking stands to the height of the carrier vehicle's load box. To do this, unlock cotter pins (3), remove pins (2), adjust the parking stands and secure the pins again.
- Detach the belt sling (6) ended with a hook (5) from the carrier vehicle's element (e.g. rear hitch) (Figure 5.1).
- Lower the carrier vehicle's load box until its rear part is located several centimetres below the spreader frame and drive the carrier vehicle away from the machine.

I.2.4.470.09.1.EN

SECTION 6

PERIODIC INSPECTIONS
MAINTENANCE

6.1 PERIODIC MAINTENANCE SCHEDULE

Table 6.1. Expected periodic inspections of the machine

Inspection	Description	Inspection conducted by
A	Inspection conducted daily before the first start or every 10 hours of continuous operation in shift mode.	User
B	Inspection performed every 50 engine working hours. Before commencing work, perform also all the activities included in the scope of daily inspection.	User
C	Inspection performed every 250 engine working hours. <i>or every 12 months depending on which occurs first</i> Before commencing work, perform all the activities which are part of the inspection conducted every 50 working hours.	Warranty Service
D	Inspection performed every 500 engine working hours. <i>or every 12 months depending on which occurs first</i>	Warranty Service
E	Inspection conducted every 4 years of the machine use.	Warranty Service
F	Inspection should be conducted as needed.	User
G	Inspection carried out once a year, right after the end of the season	User

During the warranty period, C, D, and E inspections are performed by a manufacturer service point. After the warranty period, we recommended that these inspections should be performed by specialised workshops. A, B, F and G inspections are performed by the machine operator according to the schedule.



DANGER

Before inspection, make sure the machine is secured against unauthorized start-up.

Table 6.2. Machine inspection schedule

Description of activities	A	B	C	D	E	F	G
Inspect rollers and conveyor belt	•						
Adjust rollers and conveyor belt						• ⁽²⁾	
Inspect and replace of conveyor belt brushes						• ⁽²⁾	
Replacement of conveyor belt brushes						•	
Inspect spreading disc	•						
Inspect hydraulic system	•						
Check technical condition of electrical system	•						
Inspection of tightening torque of nut and bolt connections		•					
Clean brine filter						• ⁽²⁾	
Chang the hydraulic oil filter (accessory)				• ⁽¹⁾			
Checking oil level in the conveyor drive transmission			• ⁽¹⁾				
Changing oil in the conveyor drive transmission				• ⁽¹⁾			
Replacement of hydraulic hoses					•		
Post-season inspection							•
Lubrication – according to a separate schedule							
<p>⁽¹⁾ - or every 12 months depending on which occurs first ⁽²⁾ - <i>at least once a month</i> A, B, C, D, E, F, G - <i>type of inspection (see Table 6.1)</i></p>							

6.2 INSPECT ROLLERS AND CONVEYOR BELT

Exercise due care and keep a safe distance from working machine while checking guidance of conveyor belts. The inspection involves checking whether the moving conveyor belt tends to shift laterally. If it does, first make certain that the rollers (the drive and tensioning roller) are clean.

During the machine's operation season, inspect rollers for dirt every day. Pay special attention to places of spreading material accumulation on the inside of the conveyor belt at the tensioning roller.

Turn of the conveyor drive before you check or clean rollers. After cleaning, check again whether the belt guidance is correct. Adjust the rollers, if the belt still tends to shift laterally.



IMPORTANT

Remember to regularly check that the conveyor belt is clean. Contamination of rollers is the most common cause of belt and bearing failures.

Check the conveyor belt guidance every day. Adjust the conveyor belt, if it is not positioned centrally on the tensioning and drive roller.



DANGER

Inspect conveyor belt guidance the machine is parked and the conveyor drive is off. Exercise extra caution careful during inspection.



DANGER

Inspect and clean the conveyor belt rollers only when the conveyor drive is turned off.

J.2.4.470.04.1.EN

6.3 ADJUST ROLLERS AND CONVEYOR BELT

The conveyor belt tends to stretch during normal machine operation. This is a normal phenomenon. Regularly check conveyor for correct operation.

If the conveyor belt slips on the drive roller, adjust the belt tension.

If the belt does not move centrally on the rollers, adjust the conveyor rollers.

Conveyor belt may only be tightened when the conveyor drive is off. Conveyor belt is tightened by means of bolts (1) and (2) located on the front wall of the tank (Figure 6.1). Turn both bolts (1) and (2) clockwise. To avoid shifting the belt sideways to the edge of the roller, turn both bolts by the same number of rotations.

ADJUST THE TENSIONING ROLLER

Before starting the adjustment (figure 6.3), loosen the

ADJUST CONVEYOR BELT TENSION

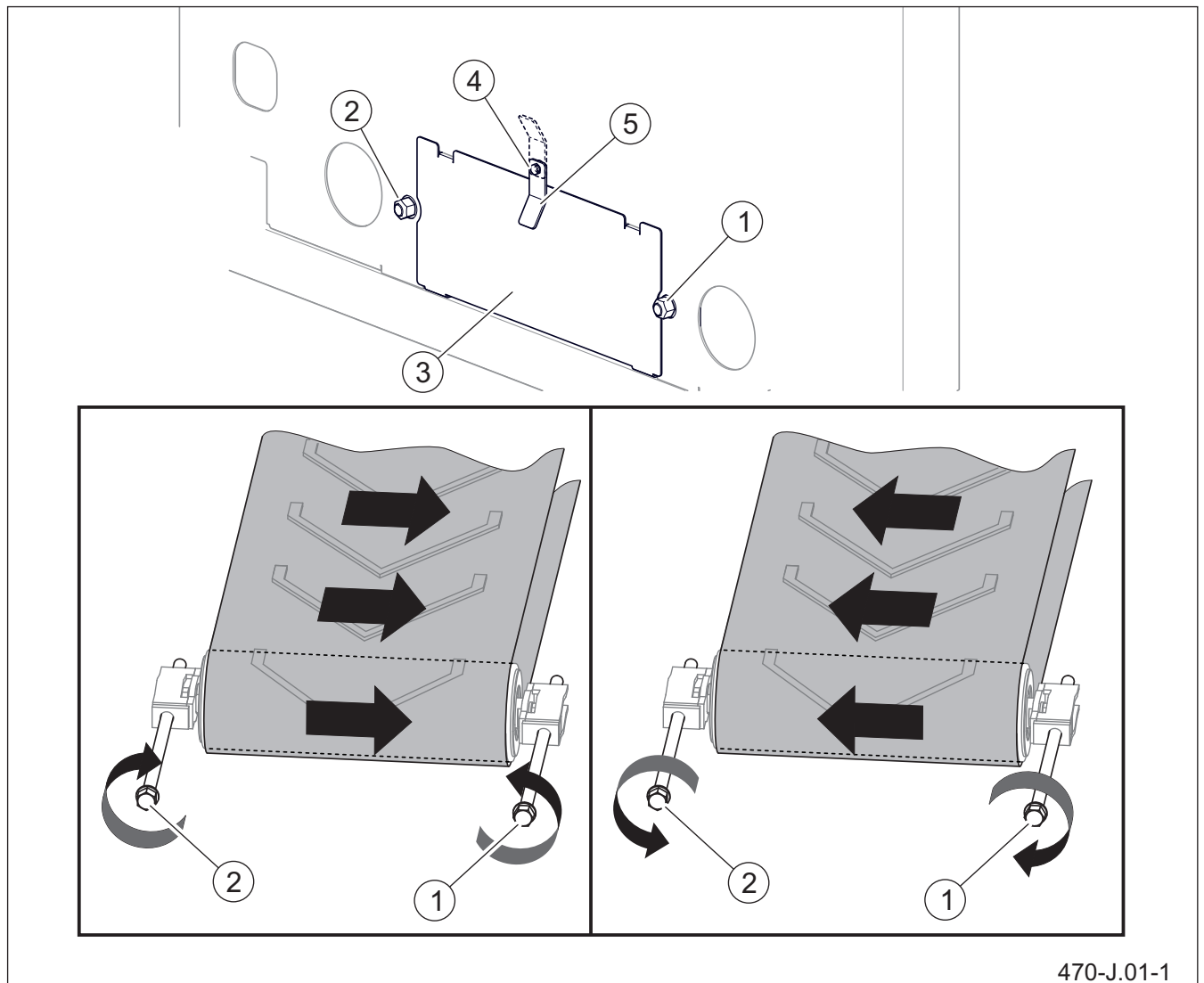

470-J.01-1

Figure 6.1 Adjustment of tightening roller
 (1)(2) adjustment bolts (3) cover (4) M8x30 bolt (5) bracket

! DANGER

Conveyor belt adjustment is performed when the sand spreader is parked and the conveyor drive is switched on. Be especially careful when making the adjustment.

! IMPORTANT

Excessive belt tension may damage the bearings and the rollers.

screw 4, turn the bracket (5) upwards and remove the cover (3).

- Turn on the spreader's hydraulic supply.
- Activate "Unloading" function in "Counters" menu on the control panel.

A detailed description can be found in the UNLOAD section.

- Conveyor belt is adjusted during conveyor operation by means of tensioning bolts (1) and (2) located on the front wall of the tank.

Depending on shifting of conveyor belt, choose the rotation direction of tensioning bolts (1) and (2).

TIP

In new sand spreaders and when replacing the conveyor belt, adjust the conveyor belt tension using the torque of 20Nm. During normal operation of the machine, adjust the conveyor belt tension using the torque of 10Nm.

the roller drive transmission bracket.

- start hydraulic drive.
- Activate "Unloading" function in "Counters" menu on the control panel.

A detailed description can be found in the UNLOAD section.

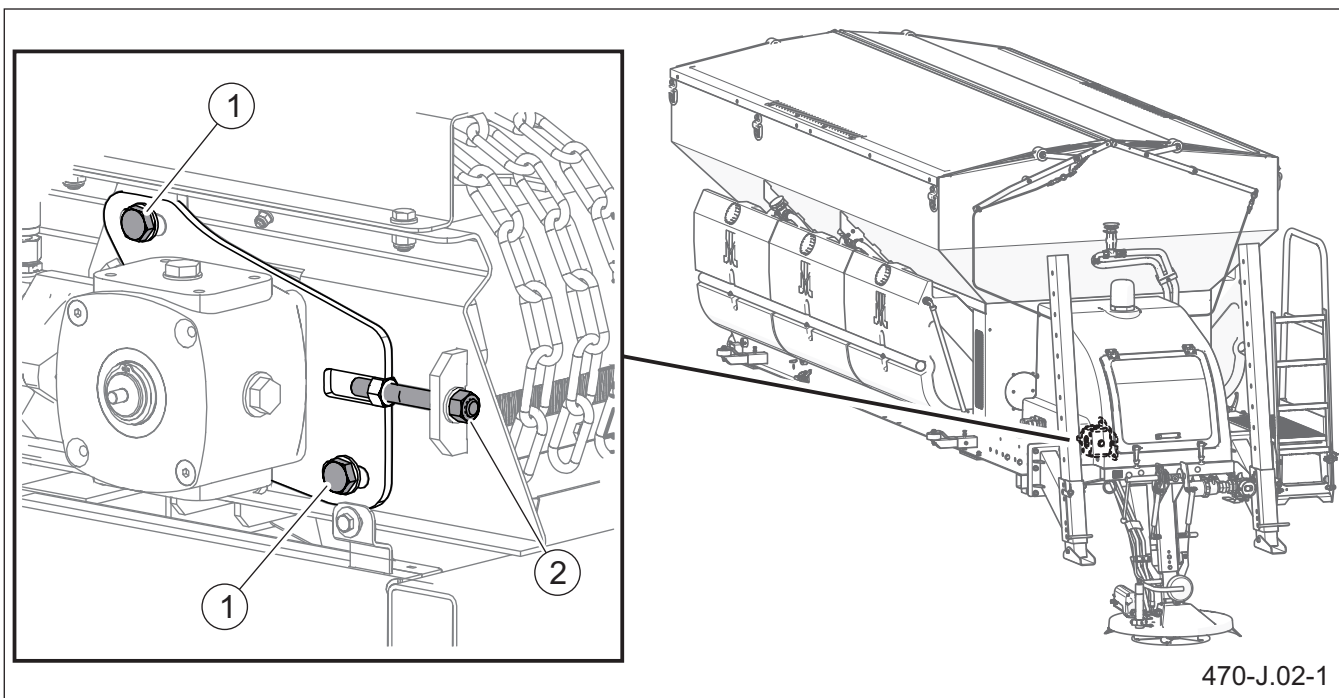

Figure 6.2 Adjustment of drive roller
(1) locking nut (2) adjusting bolt

- During the adjustment, make one turn of each bolt and wait for some time to see the effect of the adjustment. Continue adjustment until the conveyor belt is positioned centrally on the conveyor roller.

ADJUST THE DRIVE ROLLER

If the conveyor belt is shifted sideways to the edge of the conveyor drive roller, adjust the roller as needed. The adjustment is made only on one side of the conveyor (Figure 6.2) using bolt (2) by changing the position of

- Loosen nuts (1) and position the belt in the middle of the roller by means of adjusting screw (2).

During the adjustment, make one turn of bolt (2) and wait for some time to see the effect of the adjustment. Continue adjustment until the conveyor belt is positioned centrally on the conveyor roller.

- When adjusted, disengage conveyor drive, tighten nuts (1).

J.2.4.470.05.1.EN

6.4 INSPECT AND REPLACE OF CONVEYOR BELT BRUSHES

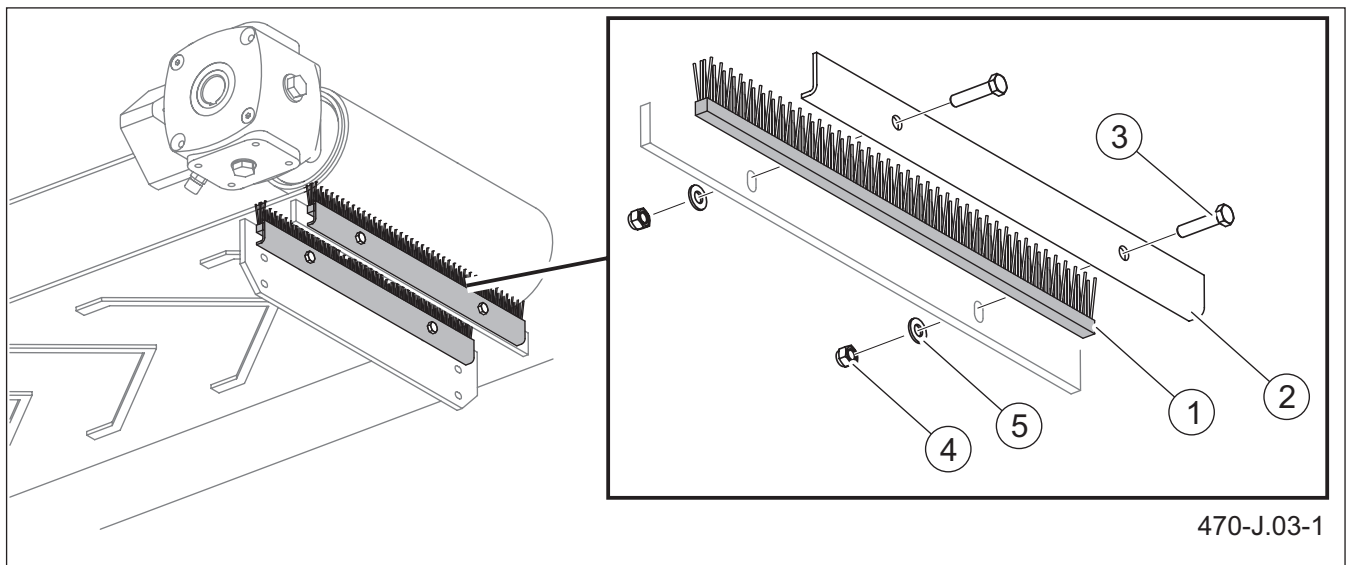

Figure 6.3 Replacement of conveyor belt brushes
(1) brush (2) clamping strip

(3) bolt (4) nut (5) washer

Belt conveyor is equipped with two brushes located under the belt, near the chute. Brushes are used for collecting remains of spreading material from conveyor belt. Degree of wear of brushes should be checked periodically. Brushes should be pressed against the whole width of the lower side of the conveyor belt. In the event of confirmation of wear of the brushes, they must be replaced.

REPLACEMENT OF CONVEYOR BELT BRUSHES

- Unscrew bolts (3) and remove clamping strip (2).
- Remove worn or damaged brush (1) and replace it with a new one (Figure 6.3).
- Set the brush in parallel to the belt.
- Assemble the complete unit performing the above activities in reverse sequence.
- Replace the second brush in the same way.



DANGER

Before inspecting or replacing conveyor brushes, turn off the spreader drive and secure the vehicle's cab against access of unauthorised persons.

TIP

Regularly check the condition of brushes under the conveyor belt. In the event of confirmation of excessive wear of the brushes, they must be replaced.

The brushes should be inspected at least once a month during the working season.

TIP

Belt conveyor is equipped with two replaceable brushes with the length of L= 410 mm, part number STL4999-255662, located under the drive roller.

J.2.4.415.06.1.EN

6.5 INSPECT SPREADING DISC

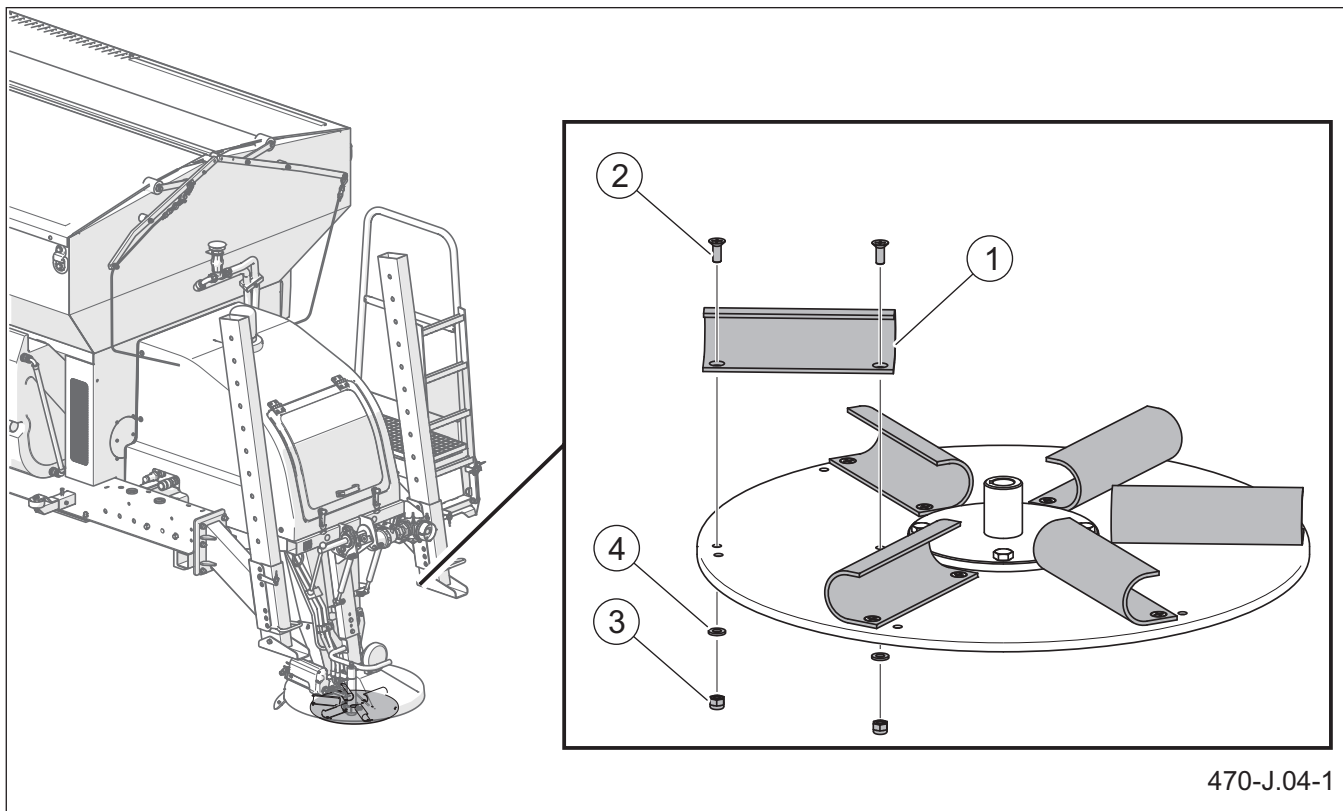

Figure 6.4 Replace spreading mechanism disc blades
 (1) blade (2) bolt (3) nut (4) washer

Technical condition of spreading mechanism disc blades should be checked periodically paying attention to mechanical damage, excessive wear and completeness of securing elements.

Table 6.3. The list of working components of spreading disc

Item	Name / Part No.	Number of items
1	Blade / 402-005-000801	6
2	Screw / 324-500-001312	12
3	Nut / 324-200-000411	12
4	Washer / 324-300-000274	12

REPLACE SPREADING DISC BLADES

- Unscrew nuts (3).
- Remove bolts (2) and washers (4).
- Replace blades (1) with new ones, check condition of bolts and nuts, if necessary replace,
- Install in reverse order.



DANGER

Spreading disc blades may be checked and replaced only if the machine is switched off and secured.

6.6 INSPECTION OF HYDRAULIC SYSTEM

Hydraulic system maintenance duties:

- visual inspection of tightness of hydraulic pumps, motors and connections,
- inspection of technical condition of conduits,
- visual inspection of hydraulic connections.

The hydraulic system must be tight. Replace any leaking or damaged seals of pumps and hydraulic cylinders. If leaks appear at connections then try to tighten the connections. Tightening torques for hydraulic lines are given in the table “*Tightening torques for hydraulic hose terminations.*” If the leak at connections is not removed, replace conduit, connector and seals (depending on place of leakage). Hydraulic oil leaks may occur also in rubber conduits, as a result of their delamination or abrasion. A conduit must be replaced with a new one.

In the event of contact of oil with skin wash the place of contact with water and soap. Do NOT apply organic solvents (petrol, kerosene). Contaminated clothing should be changed to prevent access of oil to skin. In the event of contact of oil with eye, rinse with large quantity of water and in the event of the occurrence of irritation consult a doctor.

Spilt oil should be immediately collected and placed in a marked tight container. Used oil should be taken to the appropriate facility dealing with recycling or regeneration of oils.

TIP

Bleeding of the hydraulic system is not required during normal operation of the stockpiler.



DANGER

Do not repair hydraulic system on your own. All hydraulic system repairs must be performed only by suitably qualified personnel.



IMPORTANT

Before starting work, visually inspect the hydraulic system components.



DANGER

During work on hydraulic system, use the appropriate personal protection equipment i.e. protective clothing, footwear, gloves and eye protection. Avoid contact of skin with oil.



IMPORTANT

Do NOT use the machine if the hydraulic system is unreliable. The hydraulic system is under high pressure when operating. Regularly check the technical condition of the connections and the hydraulic conduits.
The hydraulic system is filled with L-HL-32 hydraulic oil.



DANGER

Oil fires should be quenched with carbon dioxide (CO₂), foam or extinguisher steam. Do NOT use water for fire extinguishing!

TIP

The condition of hydraulic system should be inspected regularly while using the machine.

J.2.4.415.08.1.EN

6.7 CHECK TECHNICAL CONDITION OF ELECTRICAL SYSTEM

Table 6.4. Fuses and relays

Marking (FIGURE 6.5)	Name	Type
1	Control panel power fuse	MINIVAL 5A
2	extension module and sensor power supply fuse (RCE12-4/22)	MINIVAL 3A
3	Main controller power supply fuse (RC2-2/21)	MINIVAL 3A
4	Extension module and relay power supply fuse (RCE12-4/22)	MINIVAL 20A
5	Main controller power supply fuse (RC2-2/21)	MINIVAL 3A
6	Sensor power supply fuse (RC2-2/21)	MINIVAL 3A
7	Sensor power supply fuse (RCE12-4/22)	MINIVAL 2A
8	Engine start/stop relay power supply fuse (only on spreaders with internal combustion engine)	MINIVAL 15A
P1, P2	Electric spreading direction adjustment cylinder relay	Micro 280 10/15A 24V
P3	Rear lamp relay	Micro 280 15A 24V
P4	Warning beacon relay	Micro 280 15A 24V
R1	Engine start-up relay. (only on spreaders with internal combustion engine)	Micro 280 15A 24V
R2	Engine shutdown relay. (only on spreaders with internal combustion engine)	Micro 280 15A 24V
R3	Relief valve power supply relay (only on spreaders with internal combustion engine)	Micro 280 15A 24V

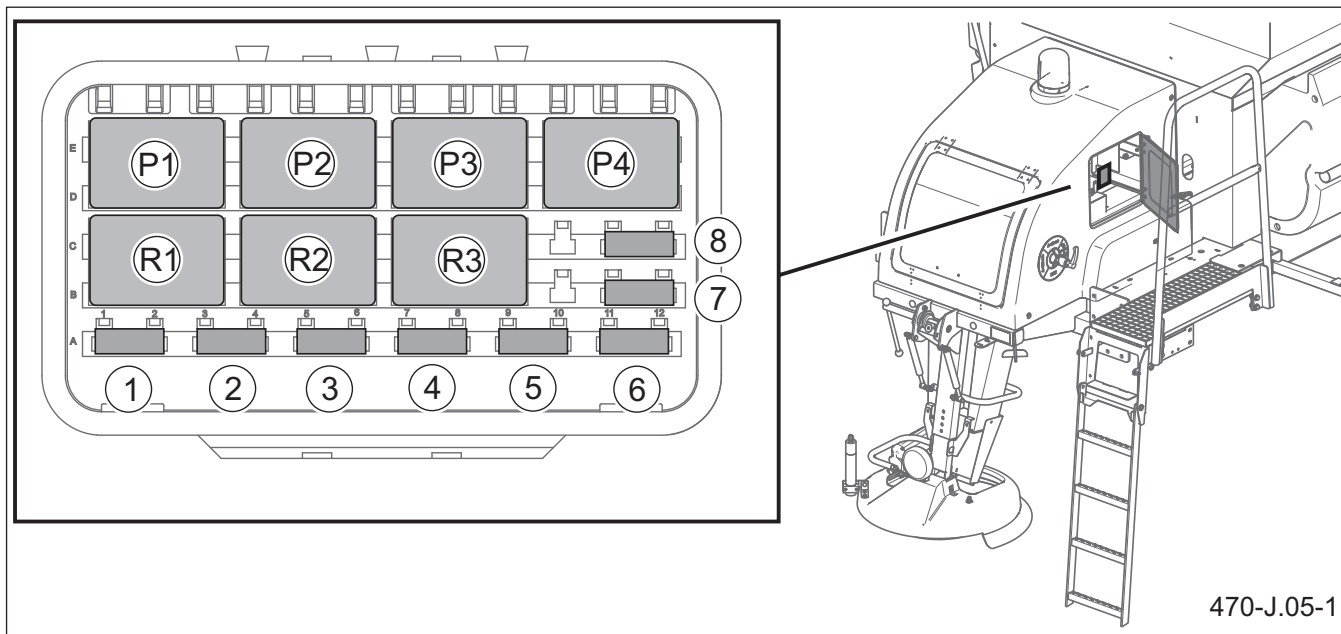

Figure 6.5 Fuses and relays
(P1-P4) relays 1-8 fuses



DANGER

Do not repair electric system on your own. All electric system repairs must be performed only by suitably qualified personnel.

Electrical system maintenance is conducted during the periodical inspection of the control and lighting system operation.

In case of bulb burnout in beacon light or fog light, replace the bulbs. The list of bulbs is presented in the table “*List of lighting components.*”

In the event of a fault in the electrical system, check the fuses. Fuses and relays are located in hydraulic unit enclosure under a cover. Remove a blown fuse from the holder and replace it with a new one. The list of fuses and relays is shown in the figure and table “*Fuses and relays*”

Table 6.5. List of lighting components

Lamp type	Bulb type	Quantity [item]
Beacon light 2RL-007 550-021	H1, 70W 24V	1
Fog lamp M56 red 56/03/01	BA15S P21W 24V	1



IMPORTANT

Before beginning work on electrical system, disconnect the machine from power source (carrier vehicle power cord)

J.2.4.470.09.1.EN

6.8 INSPECTION OF TIGHTENING TORQUE OF NUT AND BOLT CONNECTIONS

During maintenance or repair work, apply appropriate torque when tightening bolt and nut connections, unless other tightening torque values are given. Recommended tightening torques of the most frequently used bolt and nut connections are given in the table. Given values apply to non-lubricated steel bolts.

If you need to replace the fasteners (bolts, nuts), the lowest allowable strength class is 8.8. Do NOT use nut and bolt connections of a lower strength class.

Table 6.6. Tightening torque for nut and bolt connections

Thread	8.8	10.9	A2-70
	M [Nm]		
M6	10	15	7
M8	25	36	17
M10	49	72	33
M12	85	125	57
M14	135	200	91
M16	210	310	140
M20	425	610	273
M24	730	1,050	472
M27	1,150	1,650	682
M30	1,450	2,100	930

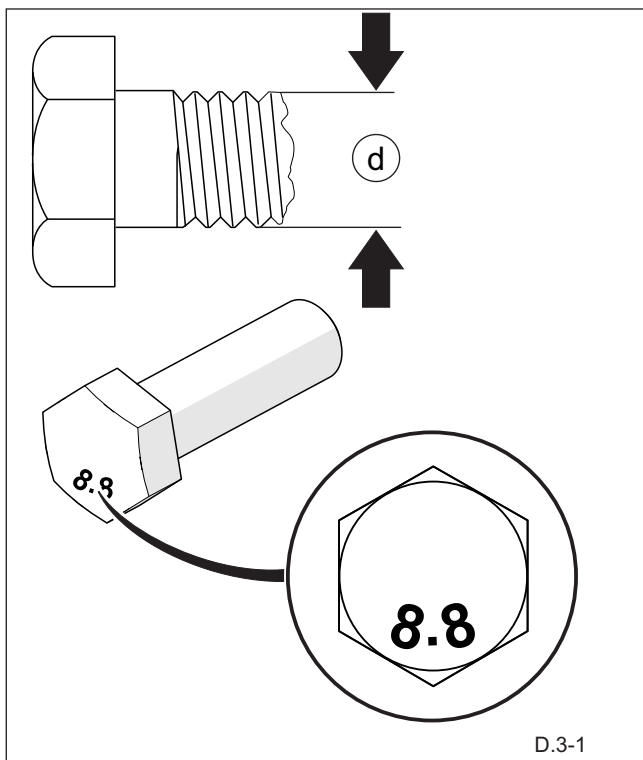

Figure 6.6 Bolt with metric thread
(8.8) resistance class (d) thread diameter

J.2.4.415.10.1.EN

6.9 CLEAN BRINE FILTER

TIP

Each time before filling the tanks with brine, check and, if necessary, tighten the bolts fixing the tanks to the frame.

It is recommended to maintain such a level of brine as to ensure that the pump is filled with the solution at all times. This prevents corrosion of internal pump components and facilitates suction of fluid in the beginning of spraying.

Brine filter cartridge should be cleaned at least once a month during the working season.

Filter of brine spray system is equipped with a reusable mesh cartridge with part number of C00100036. In the event of damage to the cartridge, replace it with a new one.

Maintenance of brine spray system involves periodical cleaning of filter, checking operation and tightness of the system.

BRINE FILTER CLEANING

- Set valve in position (A) - "filling/emptying".
- Unscrew filter housing (4).
- Remove filter cartridge (3) and wash it in water.
- Install the cartridge and tighten filter housing (4).
- Set valve in position (B) - "brine spraying".

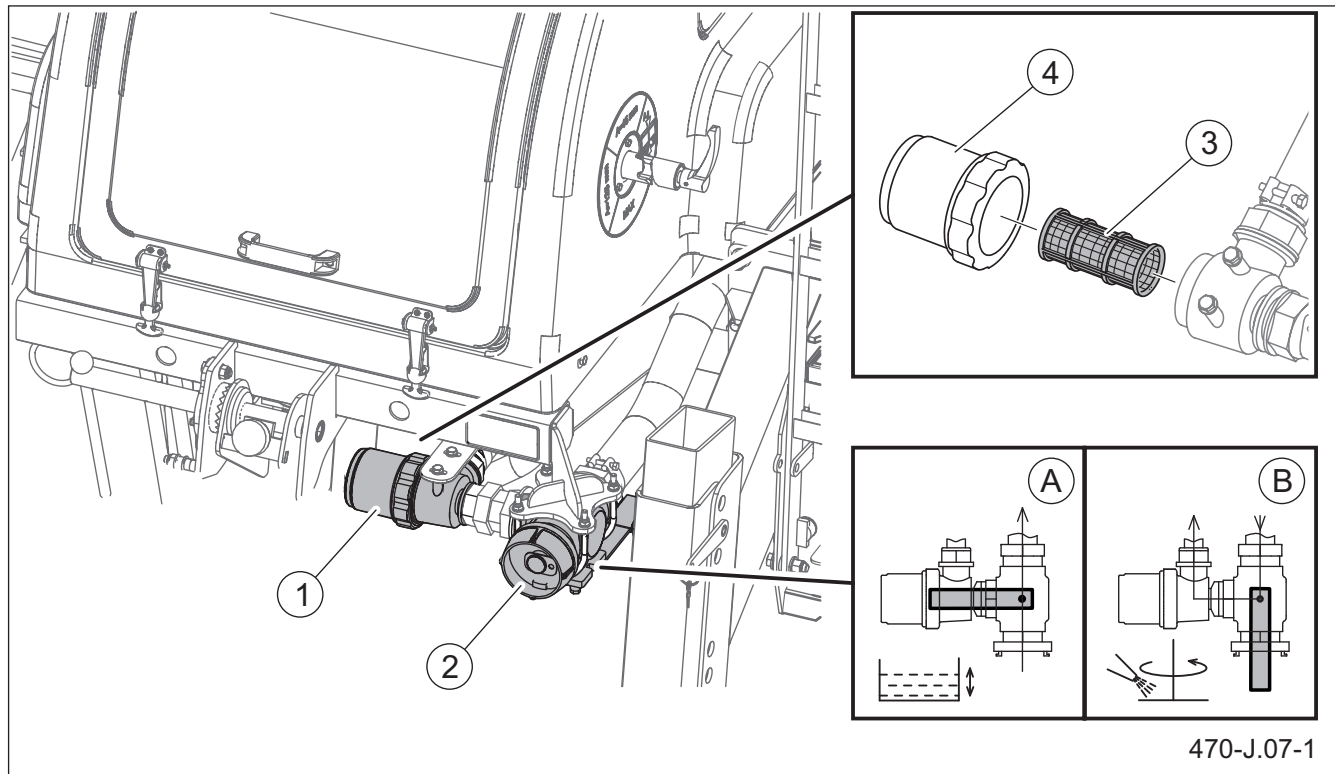

Figure 6.7 Clean brine filter

(1) brine filter

(2) valve

(3) filter mesh cartridge

(4) filter housing

(A) valve in the "filling / drain" position

(B) valve in "brine spray" position

J.2.4.470.15.1.EN

6.10 REPLACEMENT OF OIL FILTER

The spreader can be also equipped with a pressure oil filter installed in the hydraulic supply line. Oil filter cartridge should be periodically replaced.

During the warranty period the filter cartridge may be replaced by the authorised service.

In order to replace oil filter cartridge:

- Unlock the catches and open the rear cover.
- Unscrew the filter cover.
- Remove filter cartridge.
- Lubricate the seal surface with oil.
- Insert a new filter cartridge and screw on the filter housing.

The hydraulic system is vented automatically during machine operation.



DANGER

Before working on the hydraulic system, disconnect the machine from the hydraulic supply and reduce the residual pressure in the system.



DANGER

When working with hydraulic system, use the suitable personal protection equipment i.e. protective clothing, footwear, gloves, eye protection. Avoid contact of skin with oil.

TIP

Installed in the hydraulic system is a replaceable filter cartridge, part number CCH306FS1
Replace oil filter cartridge every 500 engine working hours or once a year.

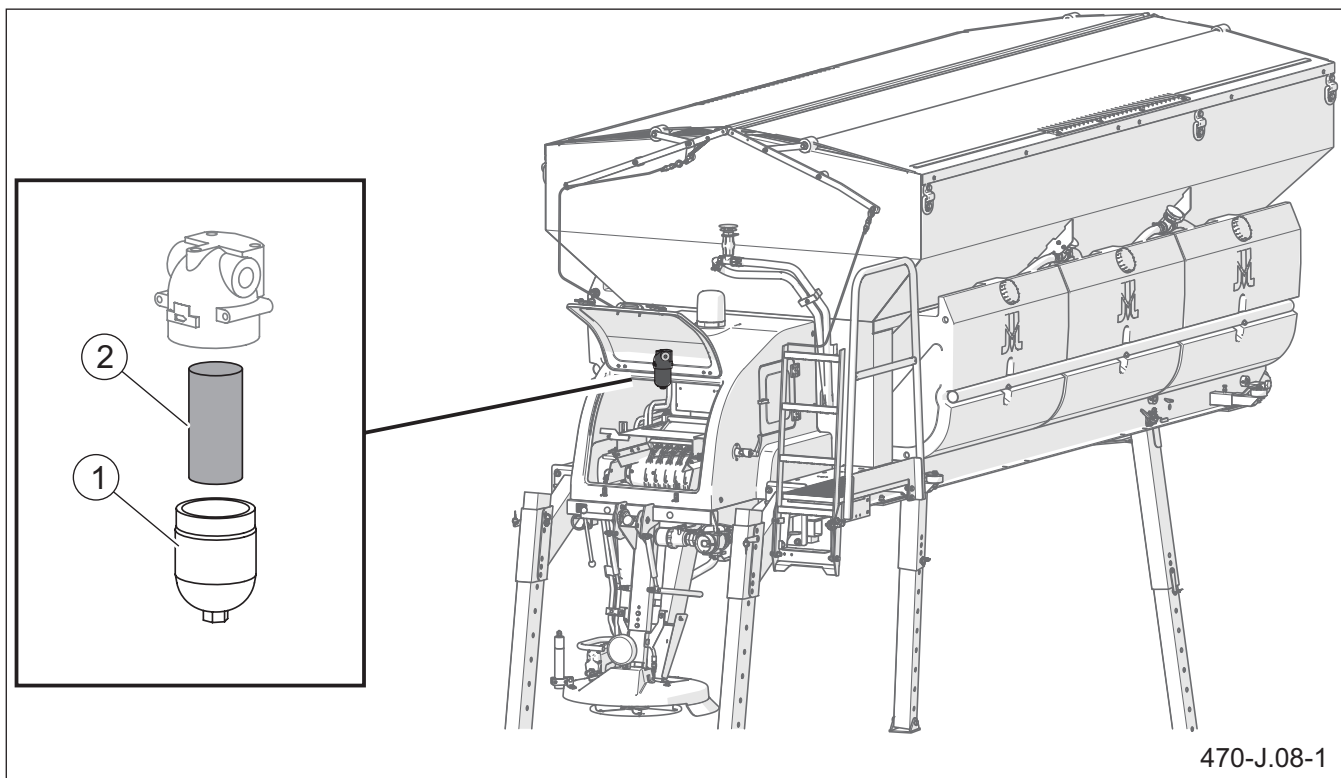

470-J.08-1

Figure 6.8 Replace the oil filter (accessory)
(1) oil filter housing (2) replaceable filter cartridge

J.2.4.470.16.1.EN

6.11 CHECKING OIL LEVEL AND CHANGE OIL IN CONVEYOR DRIVE TRANSMISSION

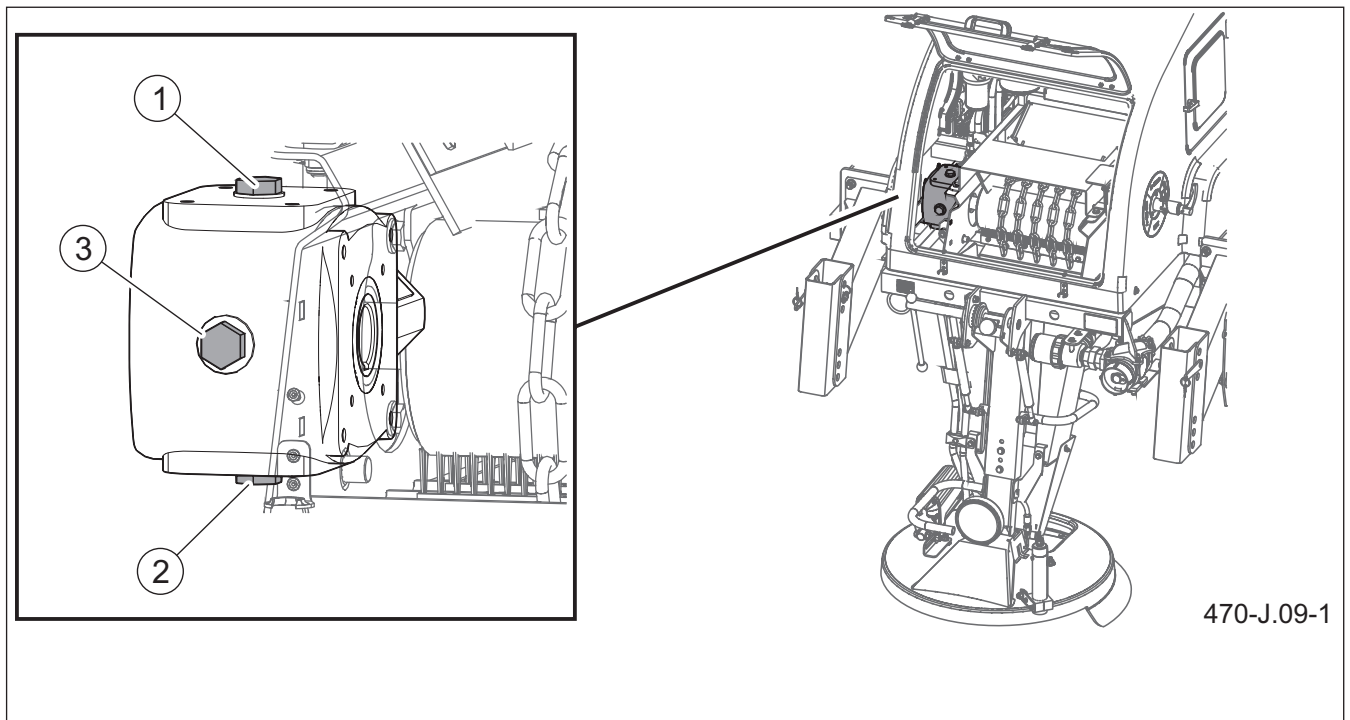

Figure 6.9 Inspect and replace oil in the gearbox
 (1) oil filler plug (2) drain plug (3) inspection plug

Maintenance of belt conveyor drive transmission involves periodical checking of oil level and changing oil (Figure 6.16). To access conveyor transmission open the cover at the back of the machine.

CHECK OIL LEVEL

- set the machine horizontally,
- unscrew inspection plug (3),
- oil level should reach the lower edge of the inspection plug opening (3),
- if necessary, add oil through filler opening (1) to the required level.

CHANGE OIL

- Unscrew filler plug (1),
- Unscrew drain plug (2) and drain oil to a previously prepared container.
- Tighten drain plug (2) and pour new oil through filler plug opening (1).
- Check that air vent in filler plug (1) is not blocked,

if necessary clean the air vent.

- Tighten filler plug (1).

Used oil should be taken to the appropriate facility dealing with recycling or regeneration of oils.

If a leak is noticed, carefully inspect seals and check oil level. Operation of the transmission with insufficient oil level or without oil may cause permanent damage to the transmission mechanisms.

During the warranty period the transmission may only be repaired by the authorised service.

TIP

It is recommended to check oil in the belt conveyor drive transmission before commencing the working season but no less frequently than every 250 engine hours. Change oil every 500 hours of operation or once a year, depending on which occurs first and when the transmission is repaired. To lubricate the belt conveyor drive transmission use 0.6 L grade SAE 90 EP transmission oil.

J.2.4.415.17.1.EN

6.12 REPLACE HYDRAULIC LINES

Rubber hydraulic conduits must be replaced every 4 years regardless of their technical condition. The replacement should be entrusted to specialist repair workshops.

Information concerning hydraulic lines can be found in the spare parts list.



IMPORTANT

Flexible hydraulic lines must be replaced every 4 years due to their working characteristics and material (ageing, high pressure, variable loads).



DANGER

Do not repair hydraulic system on your own. All hydraulic system repairs must be performed only by suitably qualified personnel.

Table 6.7. Hydraulic line terminal tightening torque

Conduit size	Tightening torque
DN	[Nm]
6	30÷50
8	30÷50
10	50÷70
13	50÷70
16	70÷100
20	70÷100
25	100÷150
32	150÷200

J.2.4.470.18.1.EN

6.13 POST-SEASON INSPECTION

In the winter season spreader operation is usually short, but intensive, followed by a long storage period. The post-season inspection, carried out immediately after the completion of winter road maintenance, will allow you to keep the machine in its best technical condition before the next season.

This inspection covers the following:

- machine cleaning
- machine maintenance,
- machine protection

PROCEDURE

- Thoroughly clean and wash the machine.
See CLEAN THE MACHINE, CLEAN THE BRINE FILTER.
- Inspect the machine, inspect technical condition of individual components. Repair or replace any

used or damaged components.

- Paint defects must be cleaned of rust and dirt, thoroughly degreased, and then preserved by applying anti-corrosive agents to the work surfaces.
- Lubricate and maintain the machine each time after washing.

Lubricate the machine according to the schedule and apply a thin layer of grease or other preservative to all metal surfaces that are not painted (especially working elements). Do not use old oils and greases for maintenance.

- Machine should be kept in closed or roofed building.

See STORAGE.

J.2.4.470.19.1.EN

6.14 MACHINE CLEANING

- The machine should be cleaned as needed. Before using the pressure washer the user is obliged to acquaint himself with the operating principles and recommendations concerning safe use of this equipment.
- Before washing carefully clean the machine, pay special attention to accumulation of spreading material on the inner side of the conveyor belt near the tensioning roller.
- The machine may only be washed with clean running water. Cleaning detergents with neutral pH may be used, which do not react aggressively with the machine's structural elements.
- The use of a pressure washer increases washing effectiveness but care must be taken during work. During washing, the washer nozzle may not be placed closer than 50 cm from the cleaned surface.
- Water temperature should not exceed 55°C.
- Do not direct water jets directly at system elements and equipment i.e. control valves, bearings, hydraulic cylinders, electric and hydraulic plugs, lights, electrical connections, information and warning decals, identification plate, conduit connections, lubrication points, control panels, safety switches, etc. High pressure water jets may get inside the machine and cause mechanical damage or corrosion.
- For cleaning and maintenance of plastic coated surfaces, use clean water or special preparations designed for this purpose.
- Do not apply organic solvents, preparations of unknown origin or other substances, which may cause damage to lacquered, rubber or plastic surfaces. In the event of doubt it is recommended to make a test on an unseen surface area.
- Surfaces smeared with oil or grease should be cleaned by application of white spirit or other degreasing agents and then washed with clean water with added detergent. Follow the cleaning agent manufacturer instructions.



DANGER

Carefully read the instructions for application of detergents and maintenance preparations. While washing with detergents, wear appropriate protective clothing and goggles protecting against splashing.



IMPORTANT

Remains of material containing salt cause quick corrosion of metal parts.

TIP

Proper machine maintenance and storage improve durability.

- Detergents should be kept in original containers, optionally in replacement containers, but very clearly marked. Preparations may not be stored in food and drink containers or in unmarked containers.
- Ensure cleanliness of elastic conduits and seals. The plastic from which these elements are made may be susceptible to organic substances and some detergents. As a result of long-term reaction of some substances, the ageing process may be accelerated and risk of damage increased. Rubber elements should be maintained with the aid of special preparations after previous thorough washing.
- Rubber components should be washed with warm soapy water or 10% glycerol alcohol mixture. You can also use liquid ammonia (do not use diesel oil, gasoline, turpentine or similar solvents).
- Clean the chains with a brush and kerosene, preserve with graphitized grease diluted with kerosene or gasoline, applying the mixture with a brush to the chain links.
- Observe the rules of environmental protection and wash the machine in a place designed for this purpose.

- Washing and drying the machine must take place at temperature above 0°C.
- Electronic components and control panel may be cleaned only with a soft cloth.
- Lubricate and maintain the machine each time after washing.

J.2.4.415.19.1.EN

6.15 STORAGE

- After finishing work, clean the machine thoroughly (See MACHINE CLEANING)
- After cleaning, inspect the whole machine, inspect technical condition of individual elements. Used or damaged elements should be repaired or replaced.
- In the event of damage to the paint coat, clean rust and dust from damaged area, degrease and then paint with undercoat and after it is dry, paint with topcoat, retaining uniform colour and thickness of the protective coating. Until the time of touch-up painting, the damaged place may be covered with a thin layer of grease or anticorrosion preparation.
- The sand spreader's tank should be emptied and covered with tarpaulin cover.
- If the machine will not be used for a long time, protect it from adverse weather conditions, especially those which initiate corrosion of steel, have aggressive impact on anticorrosion coating and accelerate ageing of stockpiler belt.
- In the event of a prolonged storage, it is essential to lubricate all components regardless of the date of the last lubrication.
- It is recommended that the machine be stored in a closed or roofed room (cool and dry), where it is not exposed to sunlight and away from heating devices.
- Loosen the conveyor belt on the tensioner.
- The machine must be secured for storage so that operating components and hydraulic lines (especially flexible lines) do not remain under pressure.
- When the machine in storage for an extended period, disconnect the control panel. Secure the electrical connector with a plug.

J.2.4.470.20.1.EN

6.16 TROUBLESHOOTING

Table 6.8. Troubleshooting

Fault (Alarm)	Possible cause	Solution
Control panel is not working	Main switch of control panel is off	Turn on the main switch (power supply)
	Electric lead is disconnected from control panel	Connect the power supply to control panel
	Burnt out fuse	Replace
	No contact in electrical connections	Clean or replace a connection
Belt conveyor does not move or does not move smoothly	Oil level in carrier vehicle hydraulic system is too low	Check and add oil if necessary
	Too slack belt is slipping on drive roller	Adjust according to the operator's manual
	Hydraulic system is damaged	Repair *
	Damaged transmission of conveyor belt drive	Repair *
Hydraulic system malfunction	Oil level in carrier vehicle hydraulic system is too low	Check and add oil if necessary
	Leakage in hydraulic system	Check and correct the fault
Spreading disk malfunction	See "Hydraulic system malfunction"	See "Hydraulic system malfunction"
	Damaged hydraulic motor of spreading disc drive	Repair *
Brine spray system does not work	Brine level in tanks is too low	Check brine level on the brine level indicator, supplement brine.
	Brine valve is set in "fill/drain" position	Set the valve in "brine spray" position
	Oil level in the system is too low	Check oil level in the carrier vehicle's system, add oil if necessary.
	Leakage in hydraulic system	Check and correct the fault
	Clogged brine filter	Check and clean if necessary
	Brine pump drive damaged	Repair *
	Leakage in hydraulic system	Check and correct the fault
Lights do not work	Burned-out bulb	Replace
	Damaged relay	Replace

Fault (Alarm)	Possible cause	Solution
Incorrect spreading of material	Incorrect machine settings	Set the belt conveyor barrier in a manner suitable for a given type of spreading material, conduct a test and correct settings.
	Electrical spreading direction adjusting cylinder is incorrectly set	Check and adjust according to operator's manual
	Damaged relay in fuse box	Replace
	Damaged spreading disc blades	Replace
* during the warranty period inspections and repairs are carried out by authorised service		

J.2.4.470.21.1.EN

6.17 CONSUMABLES

Table 6.9. List of consumables

Place of application - name	Quantity	Number / type / standard
Reduction gear - gear oil	0.6 L.	SAE 90 EP
Hydraulic system - pressure oil filter (filter cartridge)	1 item	CCH306FS1
Brine spray system - filter (mesh filter cartridge)	1	8074008 (C00100036)
grease	-	ŁT-43-PN/C-96134

J.2.4.415.22.1.EN

SECTION 7

LUBRICATION SCHEDULE

7.1 LUBRICATION

Lubrication of the machine should be performed according to the specified schedule or each time after washing the machine, regardless of the date of previous lubrication. Keep lubrication points clean as excessive amount of lubricant causes dirt to accumulate. Lubrication should be performed using generally available tools such as manually or foot operated pneumatic grease guns, etc. filled with a recommended grease. Before commencing lubrication, remove old grease and other contaminations. Check grease nipples and set of stoppers. If necessary, supplement missing elements.

After finishing work, remove and wipe off excess oil or grease.



IMPORTANT

Empty grease or oil containers should be disposed of according to the recommendations of the lubricant Manufacturer.



DANGER

Before starting work, protect the machine against accidental starting by unauthorized persons.

L.2.4.415.01.1.EN

7.2 LUBRICATION SCHEDULE

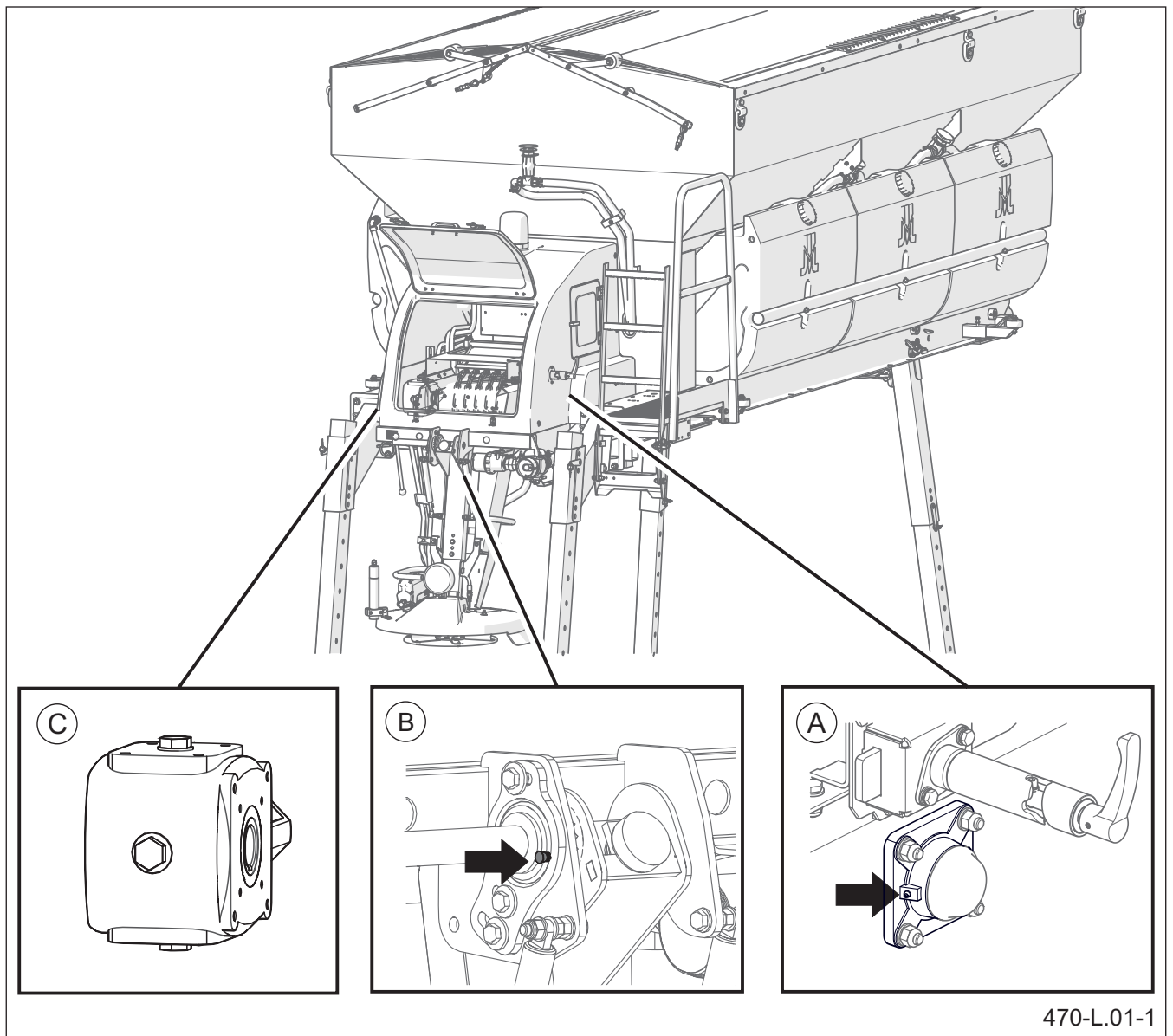

470-L.01-1

Figure 7.1 HPT70 lubrication points

Table 7.1. Lubrication schedule

Item	Lubrication point	Number of lubrication points	Type of grease grease (see table 6.9)	Frequency
A	Bearing of belt conveyor drive shaft	1	grease	20H
B	Pivot point of hopper system	1	grease	1M
C	Conveyor drive transmission	1	oil	1R

| H - hour | D - day | M - month | Y - year |

L.24.470.02.1.EN

