



PRONAR Sp. z o.o.

17-210 NAREW, UL. MICKIEWICZA 101A, PODLASKIE PROVINCE

tel.:	+48 085 681 63 29	+48 085 681 64 29
	+48 085 681 63 81	+48 085 681 63 82
fax:	+48 085 681 63 83	+48 085 682 71 10

www.pronar.pl

OPERATOR'S MANUAL

TRAILER

PRONAR T780

Translation of the original instructions

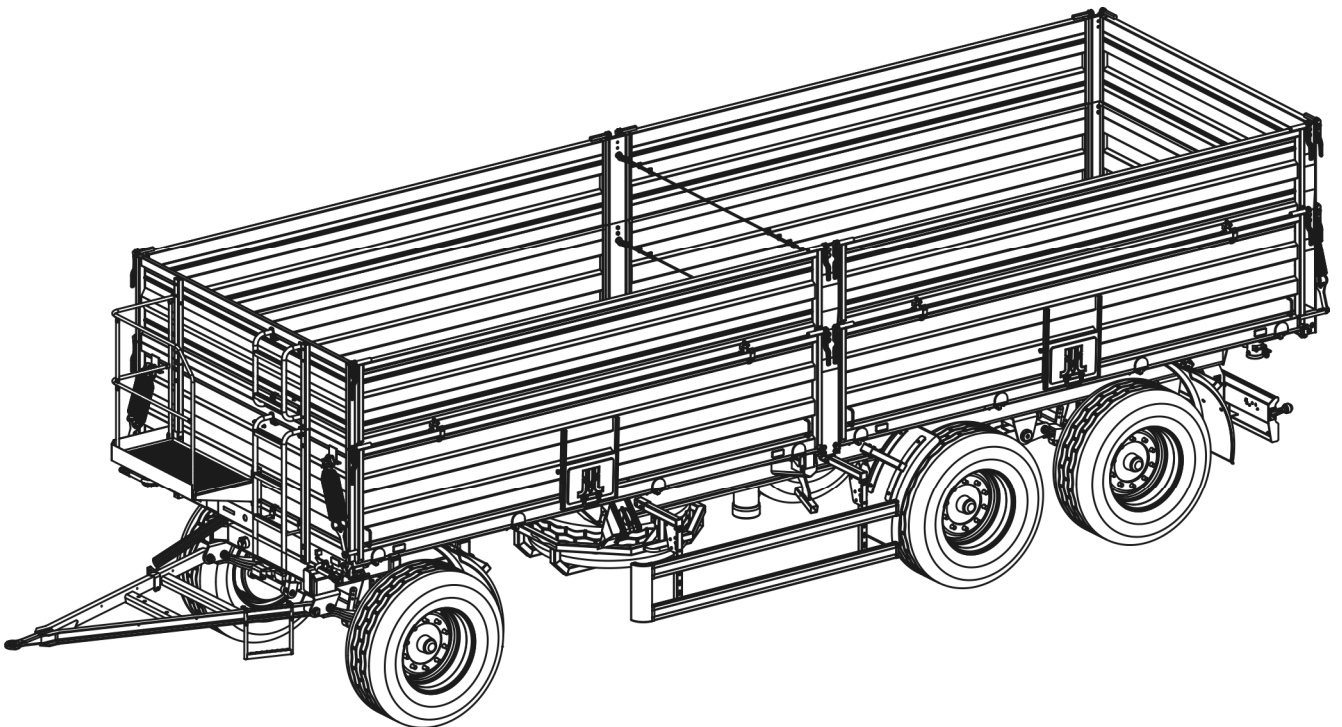

ISSUE 3B-01-2010

PUBLICATION NO 163N-00000000-UM



INTRODUCTION

Information contained herein is current at date of publication. As a result of improvements, some numerical values and illustrations contained in this publication may not correspond to the factual specification of the machine supplied to the user. The manufacturer reserves the right to introduce design changes in machines produced that facilitate operation and improve the quality of their work, without making minor amendments to these operating instructions. Please send comments and observations on the subject of the design and operation of the machine to the manufacturer. This information enables objective evaluation of the machines produced and provides indications for their further modernisation. Information on significant design changes are passed on to users with the aid of the information insert attached to these operating instructions (annexes).

The operating instructions are an integral part of the machine's documentation. Before using the tractor, the user must familiarise himself with the content of these instructions and observe all recommendations. This guarantees safe operation and ensures malfunction free work of the machine. The machine is designed to meet obligatory standards, documents and legal regulations currently in force.

The instructions describe the basic principles of safe use and operation of T780 trailer. If the information contained in the operating instructions needs clarification then the user should refer for assistance to the sale point where the machine was purchased or to the manufacturer.

Manufacturer's address:

PRONAR Sp. z o.o.

ul. Mickiewicza 101A

17-210 Narew

Contact telephones

+48 085 681 63 29

+48 085 681 64 29

+48 085 681 63 81

+48 085 681 63 82

Information, descriptions of danger and precautions and also recommendations and orders associated with user safety instructions are marked:



and also preceded by the word "**DANGER**". Failure to observe the instructions may endanger the machine operator's or other person's health or life.

Particularly important information and instructions, the observance of which is essential, are distinguished in the text by the sign:



and also preceded either word "**ATTENTION**". Failure to observe the instructions may lead to damage to the machine as a result of improper operation, regulation or use.

In order to focus the user's attention on the need to perform technical maintenance, the relevant section of the operating instructions is marked with the pictogram:



TABLE OF CONTENTS

1	BASIC INFORMATION	1.1
1.1	IDENTIFICATION	1.2
1.2	INTENDED USE	1.3
1.3	FITTINGS	1.6
1.4	WARRANTY CONDITIONS	1.7
1.5	TRANSPORT	1.8
1.6	ENVIRONMENTAL HAZARDS	1.9
1.7	WITHDRAWAL FROM USE	1.9
2	SAFETY IN USE	2.1
2.1	BASIC SAFETY PRINCIPLES	2.2
2.2	PRINCIPLES WHEN TRAVELLING ON PUBLIC ROADS	2.7
2.3	DESCRIPTION OF MINIMAL RISK	2.8
2.4	INFORMATION AND WARNING STICKERS	2.9
3	CONSTRUCTION AND PRINCIPLE OF OPERATION	3.1
3.1	TECHNICAL SPECIFICATION	3.2
3.2	CHASSIS	3.3
3.3	LOAD BOX	3.5
3.4	WORKING BRAKE	3.8
3.5	PARKING BRAKE	3.9
3.6	HYDRAULIC TIPPER SYSTEM	3.10
3.7	ELECTRICAL SYSTEM, WARNING SIGNS AND INDICATORS	3.11
4	CORRECT USE	4.1
4.1	PREPARING FOR WORK BEFORE FIRST USE	4.2
4.2	CHECKING THE TRAILER'S TECHNICAL CONDITION	4.3
4.3	ATTACHING TO TRACTOR	4.4
4.4	LOADING	4.6
4.5	TRANSPORTING LOADS	4.11
4.6	UNLOADING	4.12
4.7	DISCONNECTING FROM TRACTOR	4.16

4.8	PROPER USE AND MAINTENANCE OF TYRES	4.16
5	TECHNICAL MAINTENANCE	5.1
5.1	INSPECTION AND REGULATION OF WHEEL AXLE BEARINGS	5.2
5.2	REGULATION OF MAIN BRAKES	5.3
5.3	REGULATION OF MAIN BRAKES	5.5
5.4	PNEUMATIC SYSTEM OPERATION	5.6
5.5	HYDRAULIC SYSTEM OPERATION	5.8
5.6	LUBRICATION	5.10
5.7	INSTALLATION AND DISASSEMBLY OF THE FRAME AND CANVAS COVER	5.14
5.8	INSTALLATION AND DISASSEMBLY OF EXTENSION WALLS	5.15
5.9	ABSORBER SPRING SYSTEM MAINTENANCE	5.16
5.10	STORAGE	5.16
5.11	TRAILER PREPARATION FOR END OF SEASON	5.16
5.12	TIGHTENING TORQUE FOR NUT AND BOLT CONNECTIONS	5.17
5.13	FAULTS AND MEANS OF REMEDYING THEM	5.18
5.14	LIST OF BULBS	5.19

SECTION

1

BASIC INFORMATION

IDENTIFICATION

INTENDED USE

FITTINGS

WARRANTY CONDITIONS

TRANSPORT

ENVIRONMENTAL HAZARDS

WITHDRAWAL FROM USE

1.1 IDENTIFICATION

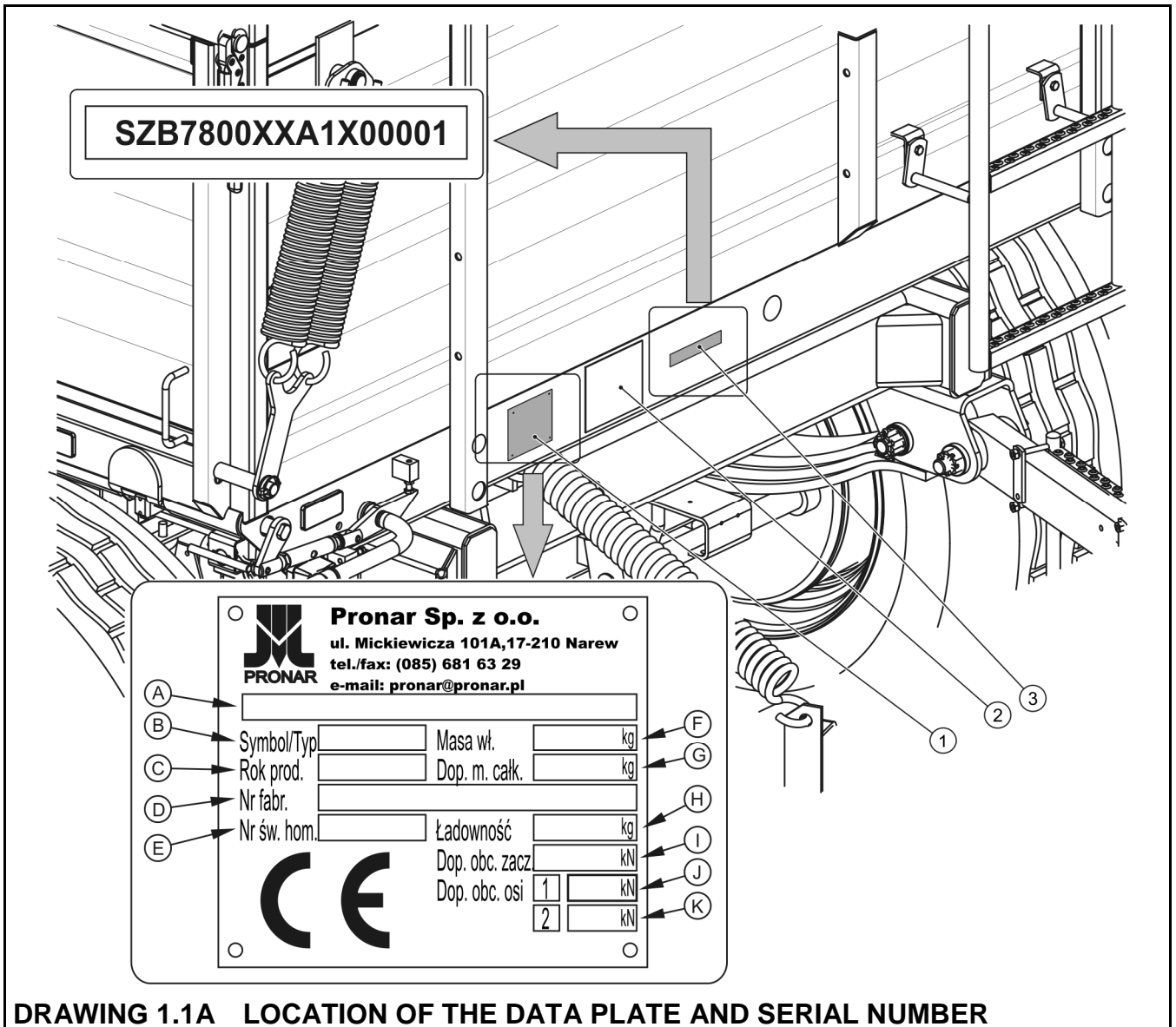

DRAWING 1.1A LOCATION OF THE DATA PLATE AND SERIAL NUMBER



(1) data plate, (2) ALB data plate, (3) serial number

The trailer is marked with a data a plate (1) and a serial number (3). The trailer's all identification markings are placed on the front beam of the upper frame, on the right side of the trailer. The factory number is stamped on a rectangle area painted silver. When buying the trailer check that the serial numbers on the machine agree with the numbers written in the *WARRANTY BOOK*, in the sales documents and in the *OPERATING INSTRUCTIONS*.

The meaning of the individual fields found on the data plate are presented in the table below:

ITEM	MARKING
A	General description and purpose
B	Symbol /Type
C	Year of manufacture
D	Seventeen digit serial number (VIN)
E	Official certificate number
F	Tare weight
G	Maximum gross weight
H	Carrying capacity
I	Maximum hitch load (not applicable)
J	Permissible front axle load
K	Permissible rear axle load

The factory numbers of the axle shafts and their types are stamped onto the identity plate secured to the central part of axle shaft beam. If the trailer is equipped with a pneumatic braking system with an automatic brake force regulator, an additional data plate is placed on the front wall of the load box – figure (1.2A).

 KNORR - BREMSE		Automatisch - Lastabhängige Bremskraftregelrichtung (ALB) Für Typ: _____ Load Sension Device for type: Dispositif de correction automatique de freinage pour type: _____					
Vorderachse, Front Axle, Essieu avant			Hinterachse, Rear Axle, Essieu arrière				
Feder - Nr Spring No Ressort No		_____		Feder - Nr Spring No Ressort No		_____	
Ventile - Nr Valves No Valves No		_____		Ventile - Nr Valves No Valves No		_____	
 $l =$ _____ mm		Eingangsdruck Input Pressure Pression d'entree		_____ bar		 $l =$ _____ mm	
Achslast Axle Load Charge essieu	Ausgangsdruck Output pressure Pression de sortie	Weg S am Hebel Stroke S at Lever Course S au Levier	Achslast Axle Load Charge essieu	Ausgangsdruck Output pressure Pression de sortie	Weg S am Hebel Stroke S at Lever Course S au Levier		
Kg	bar	mm	Kg	bar	mm		

DRAWING 1.2A EXAMPLE OF ALB DATA PLATE

1.2 INTENDED USE

The trailer is designed for transport of harvested crops and agricultural products as well as loose and bulk materials in the vicinity of the farm and on public roads at a maximum speed of 40 km/h. The trailer is also designed for transport of harvested crops and agricultural products transported on pallets.

TABLE 1.1 RECOMMENDED TYPES OF PALLETS

PALLET NAME AND SITE	LENGTH [mm]	WIDTH [mm]	HEIGHT [mm]
EUR – standard	1 200	800	144
EUR – 1/2	800	600	144
EUR – extended	1 200	1 200	144
ISO	1 200	1 000	144

The trailer must not be used in any way other than that described above. Using it as intended also involves all actions connected with the safe and proper operation and maintenance. The trailer is not intended or designed for transporting people or animals.

It is acceptable to transport construction materials, mineral fertilisers, pasture salt and mineral mixes, provided the conditions indicated in section 4. Non-compliance with the recommendations concerning transport and loading of this type of materials could damage the trailer or invalidate the guarantee.

The trailer may only be used by persons, who:

- are familiar with the contents of this publication and with the contents of the agricultural tractor Operator's Manual,
- have been trained in trailer operation and work safety,
- have the required authorisation to drive and are familiar with the road traffic regulations and transport regulations.

The braking system and the light and indicator system meet the requirements of road traffic regulations. The maximum speed of the trailer on public roads is 30 km/h in Poland (pursuant to Road Traffic Act of June 20th 1997, art. 20). In the countries where the trailer is used, the

limits stipulated by the road traffic legislation in force in a given country must be observed. The trailer's speed must not, however, be greater than the maximum design speed of 40 km/h. Axle system (axles, wheels and tyres), meet the requirements of agricultural trailers. The trailer user shall familiarise himself with the contents of the operating instructions and comply with them,

DANGER

The trailer must not be used for purposes other than those for which it is intended, in particular:



- for transporting people and animals,
- for transporting loose unsecured toxic materials, if there is a possibility of causing environmental damage,
- for transporting machines and equipment, with centre of gravity location impairing the trailer stability,
- for transporting loads with uneven loading and overloading of axles,
- for transporting unsecured loads, which may move in the load box platform,
- tipping the load box (unload) on an uneven or soft ground.

Requirements concerning trailer operation with agricultural tractor are presented in the table below.

TABLE 1.2 THE AGRICULTURAL TRACTOR'S REQUIREMENTS

CONTENTS	UNIT	REQUIREMENTS
Brake system		
Double conduit pneumatic system	-	sockets compliant with PN-ISO 1728:2007
Pressure rating of the pneumatic system	kPa	600
Hydraulic system		
Hydraulic oil	-	HL 32
Pressure rating of the system	MPa	16
Oil demand:	l	68

CONTENTS	UNIT	REQUIREMENTS
Electrical system		
Electrical system voltage	V	12
Attachment socket	-	7 polar compliant with ISO 1724
Tractor hitches		
Upper transport hitch with a minimum horizontal traction force★	kN	70
Other requirements		
Minimum power demand★★	kW / KM	107 / 146

★ The minimum towing power required to tow a trailer with a total weight of 27,000 kg, equipped with brakes.

★★ The minimum power requirements is the tractor's minimum power required to tow a single trailer in medium or difficult terrain conditions. Average or difficult terrain conditions are defined as hard and not marshy ground at an inclination not exceeding 5°. Data indicated in table (1.2) refer standard T780 trailer.

1.3 FITTINGS

Standard equipment as well as special fittings and accessories available on order are given in table (1.3).

TABLE 1.3 FITTINGS OF THE T780 TRAILER

FITTINGS	T780
<i>OPERATING INSTRUCTIONS</i>	SD
<i>WARRANTY BOOK</i>	SD
Connection lead for the electrical system	SD
Wheel wedges	SD
load box walls without chute openings 800 mm	SD
Side pull-off mechanism,	SD
Wall extensions 600 mm	SD
Rear hitch,	OP
Warning reflective triangle	OP

FITTINGS	T780
Slow-moving vehicle warning sign	OP
Fenced platform	OP
Chute	OP
Toolbox	OP
Frame with canvas cover	OP
Spare wheel	OP
Spare wheel holder	OP
Rear under run protective device	OP
Set of walls with the side chute openings - left or right execution, lateral chute channels	OP

SD – standard fittings, OP – fittings available at the customer's request

1.4 WARRANTY CONDITIONS

PRONAR Sp. z o.o., Narew guarantees the reliable operation of the machine when it is used according to its intended purpose as described in the *OPERATOR'S MANUAL*.

The repair period is specified in the *WARRANTY BOOK*.

The guarantee does not cover parts and sub-assemblies of the machine which are subject to wear in normal usage conditions, regardless of the warranty period. normal tyre wear, brake linings, mechanical damage, damage arising from improper use, regulation and maintenance.

Detailed guarantee regulations are contained in the *WARRANTY BOOK* attached to each machine.



ATTENTION!

Demand that the seller carefully and precisely fills out the *WARRANTY BOOK* and guarantee repair coupons. A missing date of purchase or sale point stamp, may make the user ineligible for any warranty repair or refund.

1.5 TRANSPORT

The trailer is ready for sale in a completely assembled state and does not require packing. Packing is only required for the machine's technical and any extra fittings. The trailer is delivered to the user either transported on a vehicle or, after being attached to a tractor, independently (towed).

ATTENTION!



When transporting independently, the user must familiarise himself with the content of these instructions and observe their recommendations. When being transported on a motor vehicle the trailer must be mounted on the vehicle's platform in accordance with the transport safety requirements. The driver of the vehicle should take particular care while transporting the trailer. This is due to the vehicle's centre of gravity shifting upwards when loaded with the machine.

When loading and unloading the trailer, comply with the general principles of workplace health and safety for reloading work. Persons operating reloading equipment must have the qualifications required to operate these machines.

The trailer should be attached firmly to the platform of the vehicle using straps or chains fitted with a tightening mechanism. The fastening equipment used must have a valid safety certificate. Wedges or other objects without sharp edges should be placed under the wheels of the trailer to prevent it from rolling. The wedges must be fixed to the platform of the vehicle. During reloading work, particular care should be taken not to damage parts of the trailer's fittings or the lacquer coating.

Fixing belts or chains can be attached to transport lugs, welded to the bottom side of lower frame. Longitudinal rails and other strong structural elements of the upper or lower frame can be also used to secure the load. When securing the load special attention should be paid to correct mounting of the lockbox.

1.6 ENVIRONMENTAL HAZARDS

A hydraulic oil leak constitutes a direct threat to the natural environment owing to its limited biodegradability. While carrying out maintenance and repair work which involves the risk of an oil leak, this work should take place on an oil resistant floor or surface. In the event of oil leaking into the environment, first of all safeguard the source of the leak, and then remove the leaked oil using available means. Remaining oil must be collected using sorbents.

1.7 WITHDRAWAL FROM USE

Should the user decide to withdraw the machine from use, the entire trailer should be taken to a scrap yard approved by local authorities. When spare parts are changed, worn out or damaged parts should be taken to a collection point for recyclable raw materials. Hydraulic oil should be taken to the appropriate facility dealing with the re-use of this type of waste.

SECTION

2

SAFETY IN USE

BASIC SAFETY PRINCIPLES

PRINCIPLES WHEN TRAVELLING ON PUBLIC ROADS

DESCRIPTION OF MINIMAL RISK

INFORMATION AND WARNING STICKERS

2.1 BASIC SAFETY PRINCIPLES

- Before using the trailer, the user must thoroughly familiarise himself with the content of these instructions. While using it, follow all the recommendations contained in them.
- The trailer may only be used and operated by persons qualified to drive agricultural tractors and agricultural machines and trained in the use of the machine.
- If the information contained in the operating instructions is difficult to understand, contact a seller who runs an authorised technical service on behalf of the manufacturer, or contact the manufacturer directly.
- Careless and improper use and operation of the trailer, and non-adherence to the recommendations included in these instructions are dangerous for the health.
- Non-adherence to the principles of safe use creates a danger for the health and life of the operator and others.
- Be warned that a minimal risk does exist, and for this reason the fundamental basis for using this trailer should be the application of safety principles and sensible behaviour.
- The trailer must never be used by persons who are not authorised to drive agricultural tractors, including children and people under the influence of alcohol or other drugs.
- The trailer must not be used for purposes other than those for which it is intended. Anyone who uses the machine other than the way intended takes full responsibility on himself for any consequences of this use.
- Any modification to the trailer frees PRONAR Narew from any responsibility for damage or detriment to health which may arise as a result.
- . In particular, check the technical condition of the hitch system, the axle system, the brake system, indicator lights and the connective elements of the hydraulic, pneumatic and electrical systems.
- The trailer can only be stood on when it is absolutely motionless and the tractor engine is switched off.
- The trailer unhitched from tractor must be immobilised with parking brake. If the machine is positioned on a slope or elevation it shall be additionally secured against

moving by placing wedges or other objects without sharp edges under the trailer's wheels.

- People or animals must not be carried.
- The trailer and tractor must not be attached if the hydraulic oil in the two machines is of different types.
- While connecting the trailer to the tractor, use the appropriate hitch. After linking the trailer, check the hitch safeguards.
- Be especially careful when attaching the machine.
- When attaching, there must be nobody between the trailer and the tractor.
- Do NOT proceed with disconnecting trailer from the tractor when load box is raised on telescopic cylinders. Exercise caution when disconnecting trailer.
- Regularly check the condition of connections and safety devices.
- Prior to tipping the load box, place the tipping pins on the intended unloading side. Check if the pins are correctly inserted and secured.
- . Using third-party pins could damage the trailer.
- The hydraulic system is under high pressure when operating.
- Regularly check the technical condition of the connections and the hydraulic and pneumatic leads.
- Prior to moving off make sure that tipping pins connecting the lockbox and the lower frame and the side wall hinge pins are secured against falling out.
- The trailer's maximum carrying capacity must not be exceeded.
- Load must be uniformly distributed and it must not obstruct visibility or hinder driving.
- Loading and unloading work should be carried out by someone experienced in this type of work.
- When unloading, tractor and trailer must be positioned to drive forward.
- Do NOT drive with an load box raised.
- Ensure that during unloading nobody is near tipped load box.

- Cut-off valve in the hydraulic tipping system limits the tipping angle of the load box when tipped to the sides. The length of the control cable controlling this valve is factory adjusted by the manufacturer and must not be changed when the trailer is used.
- People or animals must not be carried.
- Keep a safe distance from electric power lines during unloading.
- Tipping the load box must be done on hard and level ground.
- When opening load box side wall locks take particular care, because of the pressure of the load on the wall.
- Do NOT tip of the load box in windy conditions.
- When closing the rear grain chute gate or the walls take particular care to avoid crushing fingers.
- Bulk materials loaded in excess of 1 m can be unloaded by tipping the load box to the rear only.
- Tipping may only be performed when trailer is hitched to tractor.
- Assembly and disassembly of extension walls, the frame and canvas cover, can only be carried out with the use of appropriate platforms, ladders or from a ramp. These tools must be in good condition to fully protect the persons working on them against falling. The above procedure should be performed by at least two persons.
- In the final phase of folding the canvas cover, at all times hold with one hand the railing of the fenced platform or top of the front frame. Non-compliance with this rule can put the user at risk of falling.
- In the event of a fault in the hydraulic or pneumatic system, disconnect the trailer from use until the fault has been fixed.
- When connecting the hydraulic conduits to the tractor, make sure that the hydraulic systems of the tractor and trailer are not under pressure.
- Check condition of machine hydraulic system frequently, oil leaks are not permissible.
- Do NOT perform any maintenance or repairs on the load box that is loaded, raised or not supported.

- Before beginning repair works on hydraulic or pneumatic installations reduce oil or air pressure.
- In the event of injuries being caused by pressurised hydraulic oil, contact a doctor immediately. Hydraulic oil may find its way under the skin and cause infections. In the event of contact of oil with eye, rinse with large quantity of water and in the event of the occurrence of irritation consult a doctor. In the event of contact of oil with skin wash the area of contact with water and soap. Do not apply organic solvents (petrol, kerosene).
- Use the hydraulic oil recommended by the Producer. Never mix two types of oil.
- After changing the hydraulic oil, the used oil should be properly disposed of.
- When working on the tyres, wedges attached to trailer should be placed under the wheels of the trailer to prevent it from rolling.
- Repair work on the wheels or tyres should be carried out by persons trained and entitled to do so. This work should be carried out using appropriately selected tools.
- After removing a wheel, always check how firmly the nuts are screwed in. Inspection should take place each time after first use, after first journey with a load and then every 6 months.
- Check the tyre pressure regularly.
- In the event of any fault or damage whatsoever, disconnect the trailer from use until the fault has been fixed.
- During work use the proper, close-fitting protective clothing, gloves and appropriate tools. When working on hydraulic systems it is recommended to use oil resistant gloves and goggles.
- Servicing and repair work should be carried out in line with the general principles of workplace health and safety. In the event of injury, the wound must be immediately cleaned and disinfected. In the event of more serious injuries, seek a doctor's advice.
- Repair, maintenance and cleaning work should be carried out with the tractor's engine switched off and the ignition key removed.
- Regularly check the condition of the screw and nut connections.

- During the warranty period, any repairs may only be carried out by a Warranty Service authorised by the manufacturer.
- Should it be necessary to change individual parts, use only original parts or those indicated by the manufacturer. Non-adherence to these requirements may cause danger to the health and the user's and other people's lives, and also damage the machine.
- Regularly check technical condition and mounting of all guards and protective elements.
- Before welding or electrical work, the trailer should be disconnected from the power supply.
- The paint coating should be cleaned off before beginning welding work. Burning paint fumes are poisonous for people and animals. Welding work should be carried out in a well lit and well ventilated space.
- During welding work pay attention to flammable or fusible elements (parts of the pneumatic, electric and hydraulic systems, plastic parts). If there is a risk that they will catch fire or be damaged, they should be removed before commencing welding work. Before beginning work prepare a CO₂ or foam extinguisher.
- In the event of work requiring the trailer to be raised, use properly certified hydraulic or mechanical lifts for this purpose. After lifting the trailer, stable and durable supports must also be used. Work must not be carried out under a trailer which has only been raised with a lift.
- The trailer must not be supported using fragile elements (bricks or concrete blocks).
- After completing work connected with greasing, remove excess oil or grease.
- The trailer should be kept clean and tidy.
- Before climbing on to the load box, make sure unauthorised persons do not have access to the character.
- Keep a safe distance from electric power lines during unloading and when load box is raised.

- Exercise caution when climbing on top of the load box. Climbing on top of the load box is possible through the fenced platform, ladders placed on the front wall, while extension and folding steps attached inside the load box.

2.2 PRINCIPLES WHEN TRAVELLING ON PUBLIC ROADS

- When travelling on public roads, respect the road traffic regulations.
- Exceeding the maximum load capacity of the trailer may damage it, and also threaten the safety of traffic.
- If the trailer is the last vehicle in the group, a slow-moving vehicle sign should be placed on the trailer's rear load box wall – figure (2.1A).
- Do not exceed the maximum design speed. Adjust your speed to the road conditions.
- The machine must NOT be left unsecured. Securing the trailer involves engaging the parking brake and/or placing wedges or other objects without any sharp edges under trailer wheels.
- While driving on public roads the trailer must be fitted with a certified or authorised reflective warning triangle.
- The trailer is designed to operate on slopes up to 8° . Tipping of the load box can only be done when trailer is positioned on a flat surface.
- Monitor trailer's behaviour when travelling on an uneven terrain.
- Adjust driving speed to road conditions, slow down early enough when turning.

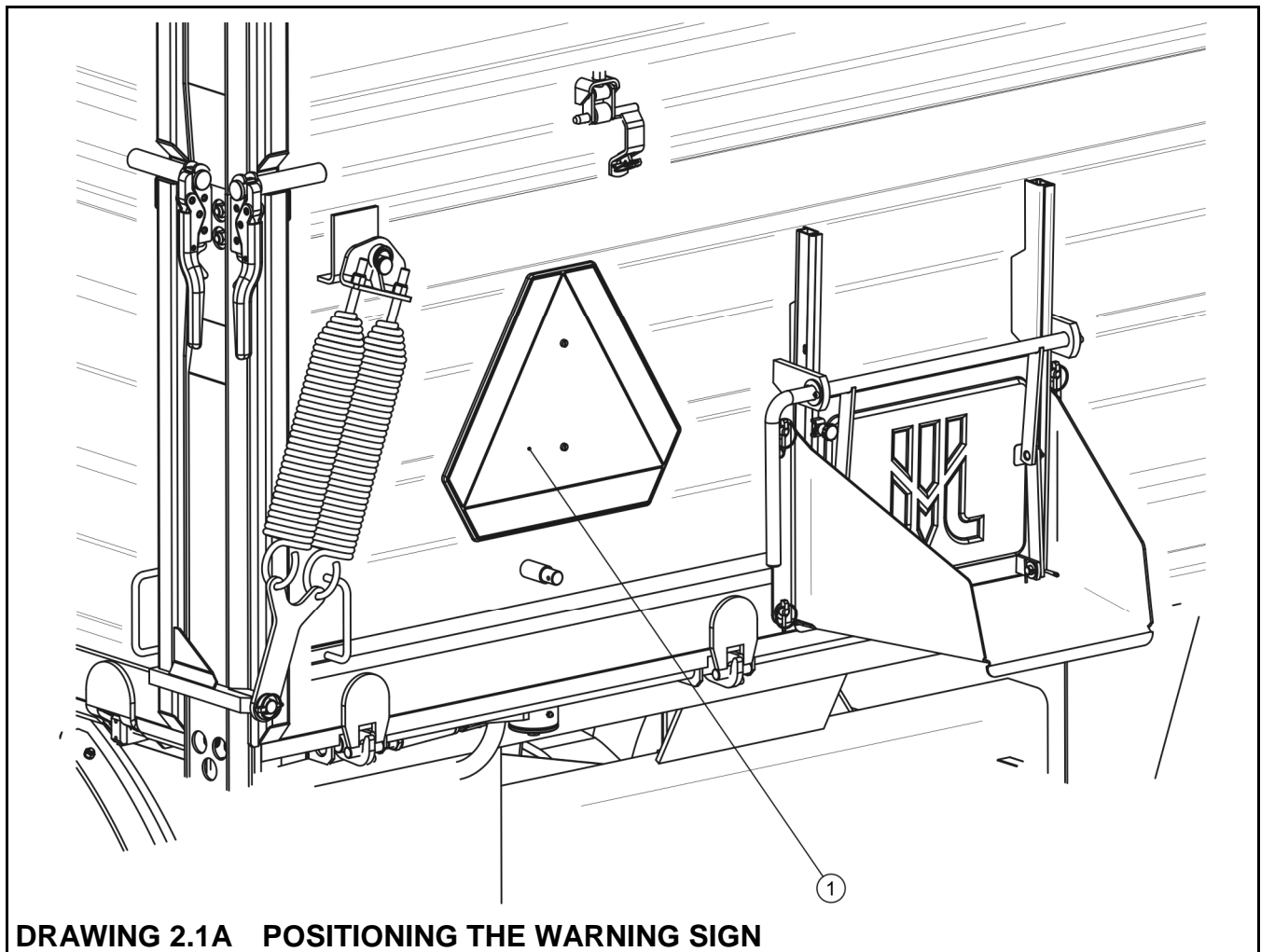

(1) *slow-moving vehicle sign*

2.3 DESCRIPTION OF MINIMAL RISK

Pronar Sp. z o. o. in Narew has made every effort to eliminate the risk of accidents. There is, however, a certain minimal risk which could lead to an accident, and this is connected mainly with the actions described below:

- using trailer for purposes other than those described in the instructions,
- being between the tractor and the trailer while the engine is running and when the machine is being attached,
- operation of the trailer by persons under the influence of alcohol or other intoxicating substances,
- operation of trailer by an authorised person,
- being on the machine during work,

- cleaning, maintenance and technical checks of the trailer.

The minimal risk may be kept to a minimum by following the recommendations below:





- prudent and unhurried operation of the machine,
- sensible application of the remarks and recommendations contained in the *OPERATING INSTRUCTIONS*,
- keeping a safe distance from forbidden or dangerous places,
- a ban on being on the machine when it is operating,
- carrying out repair and maintenance work by persons trained to do so,
- using suitable protective clothing,
- ensuring unauthorised persons have no access to the machine, especially children.

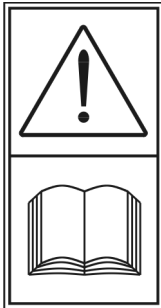

2.4 INFORMATION AND WARNING STICKERS

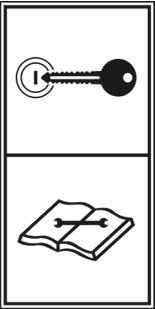
The trailer is labelled with the information and warning stickers mentioned in table (2.1). The symbols are positioned as presented in figure (2.2A). Throughout the time it is in use, the user of the machine is obliged to take care that notices and warning and information symbols located on the trailer are clear and legible. In the event of their destruction, they must be replaced with new ones. Stickers with notices and symbols are available from the manufacturer, or from the retailer where the trailer was purchased. New assemblies, changed during repair, must be labelled once again with the appropriate safety signs.

TABLE 2.1 INFORMATION AND WARNING STICKERS

ITEM	SAFETY SYMBOL	DESCRIPTION
1		<p>Before starting work, familiarise yourself with the contents of the <i>OPERATING INSTRUCTIONS</i>.</p>

ITEM	SAFETY SYMBOL	DESCRIPTION
2		<p>Before beginning servicing or repairs, switch off engine and remove key from ignition</p>
3		<p>Before climbing on the ladder in order to perform maintenance or repair is inside the load box, switch of engine and remove key from ignition. Secure tractor against unauthorised access.</p>
4		<p>Check the condition of the screw and nut connections of the wheel axles</p>
5		<p>Grease according to the recommendations in the <i>OPERATING INSTRUCTIONS</i></p>
6	<div style="border: 1px solid black; padding: 5px; text-align: center;">550 kPa</div>	<p>Air pressure in the tyres★</p>
7	<div style="border: 1px solid black; padding: 5px; text-align: center;">T780 PRONAR</div>	<p>Type of trailer</p>
8		<p>Do not support load box containing load.</p>

ITEM	SAFETY SYMBOL	DESCRIPTION
9		Keep a safe distance from electric power lines during unloading.
10		Hydraulic tipper system★★
11		Switching between hydraulic circuits I & II★★

★ - air pressure in tyres depends on tyres used

★★ - not shown on figure (2.2A), stickers are applied in the vicinity of hydraulic sockets and three-way hydraulic valve

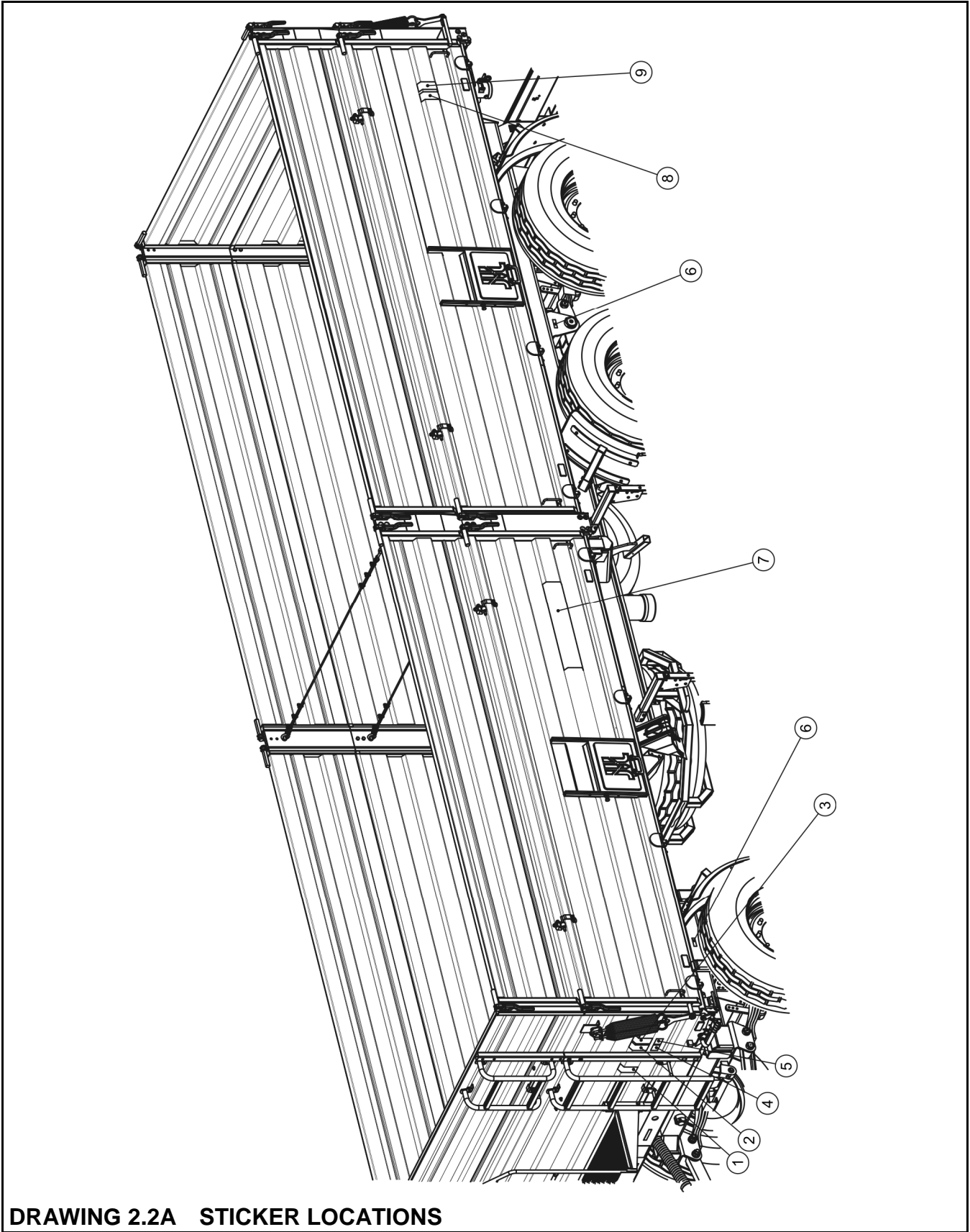

DRAWING 2.2A STICKER LOCATIONS

Labelling in line with table 2.1 „Information and warning stickers”

SECTION

3

CONSTRUCTION AND PRINCIPLE OF OPERATION

TECHNICAL SPECIFICATION

CHASSIS

LOAD BOX

WORKING BRAKE

PARKING BRAKE

HYDRAULIC TIPPER SYSTEM

ELECTRICAL SYSTEM, WARNING SIGNS AND INDICATORS

3.1 TECHNICAL SPECIFICATION

TABLE 3.1 T780 TRAILER BASIC TECHNICAL SPECIFICATION*

CONTENTS	UNIT	DATA
Dimensions		
Total length	mm	9 614
Total width	mm	2 548
Total height	mm	3 102
Axle track	mm	1 900
Axle base	mm	4 760
Internal load box dimensions:		
- length	mm	7 696
- width	mm	2 410
- height (walls + wall extensions)	mm	800 + 600
Technical specification		
Load volume	m ³	26
Load surface	m ²	18.5
Lift of load surface	mm	1 360
Load box tipping angle		
- rear	(°)	46
- sideways	(°)	45
Weights		
Tare weight	kg	7 850
Maximum legal gross weight:	kg	24,000
Maximum design gross weight	kg	27 000
Maximum legal carrying capacity:	kg	16 150
Tyres		
Tyre dimensions	-	385/65-R22.5
Wheel rim size	-	11.75x22.5 ET-30
Air pressure in the tyres	kPa	550
Other information		
Nominal voltage	V	12

CONTENTS	UNIT	DATA
Maximum design speed	km/h	40**
Hydraulic oil demand	l	68

* - Technical specifications for a standard configuration with a spare wheel (no fenced platform, canvas cover or frame)

- **The maximum speed of the trailer on public roads is 30 km/h in Poland (pursuant to Road Traffic Act of June 20th 1997, art. 20). In the countries where the trailer is used, the limits stipulated by the road traffic legislation in force in a given country must be observed. The trailer's speed must not, however, be greater than the maximum design speed of 40 km/h.

TABLE 3.2 WEIGHTS OF SELECTED ADDITIONAL FITTINGS AND ACCESSORIES

ADDITIONAL FITTINGS AND ACCESSORIES	UNIT	DATA
Set of 800 mm wall extensions*	kg	577
frame + canvas cover + fenced platform	kg	150

* Using 800 mm wall extensions instead of 600 mm wall extensions increases the trailer's weight by 106 kg.

3.2 CHASSIS

Trailer chassis consists of subassemblies indicated on figure (3.1A). Lower frame (1) of the load box is a structure are welded from steel sections. The main support elements are two longitudinal rails connected with crossbars. In the middle section and there are sockets used for mounting of the tipping ram cylinders (7). In the rear section of the frame there is lights support beam (3), to which mounted are primarily all electrical systems elements and the license plate. Axles (2) are mounted on suspension with absorber springs using plates and U screws - see figure (3.2A). Axles are made from square bars terminated with a pins, were mounted on cone bearings are wheel hubs. These are single wheels, equipped with shoe breaks activated through mechanical expander cams.

At the rear part of the frame there is it being terminated with ball pins. The support structure of the upper frame and the interlocking method allows tipping of the load box to the side and to the rear. Brackets for mounting of the upper frame are welded in the centre and on the left and right side of the front beam of lower frame.

In the front part of the trailer there are front axle suspension elements: rotator, rotator frame

(4), taper leaf springs (5) and the drawbar (6). Drawbar is fixed to the rotator's frame using pins.

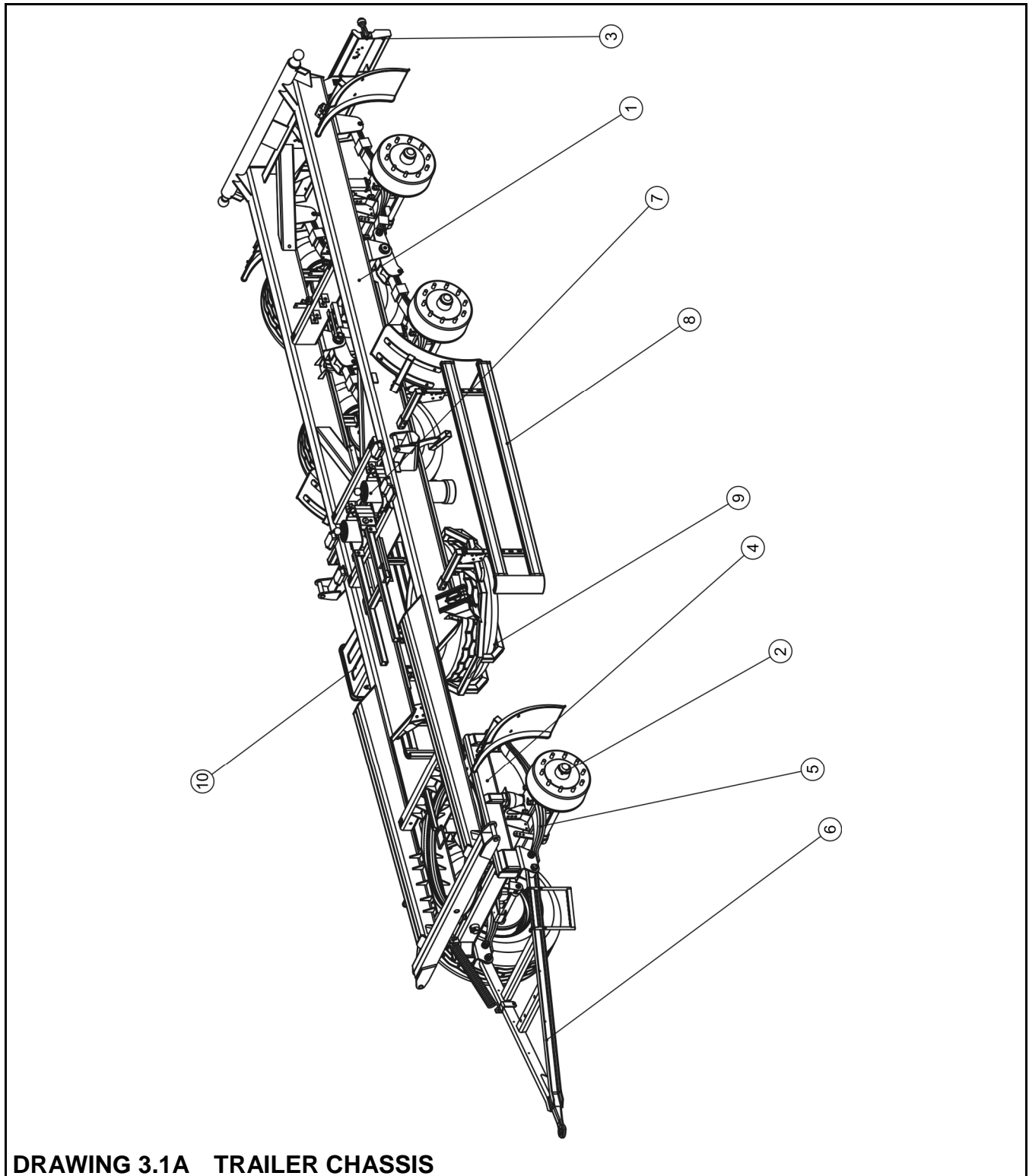

DRAWING 3.1A TRAILER CHASSIS

(1) lower frame, (2) wheel axle, (3) lights support beam, (4) rotator frame, (5) taper leaf spring (6) drawbar, (7) telescopic cylinder, (8) rear under-run protective device, (9) spare wheel holder, (10) toolbox

The height of drawbar attachment can be adjusted by moving the bracket fixing the spring to the drawbar.

Tandem axle suspension with absorber springs is mounted in the rear part of the frame – figure (3.2A). It is composed of rocker arm (1) and taper leaf springs (2). The whole assembly is connected using pins (3), (4) and (5).

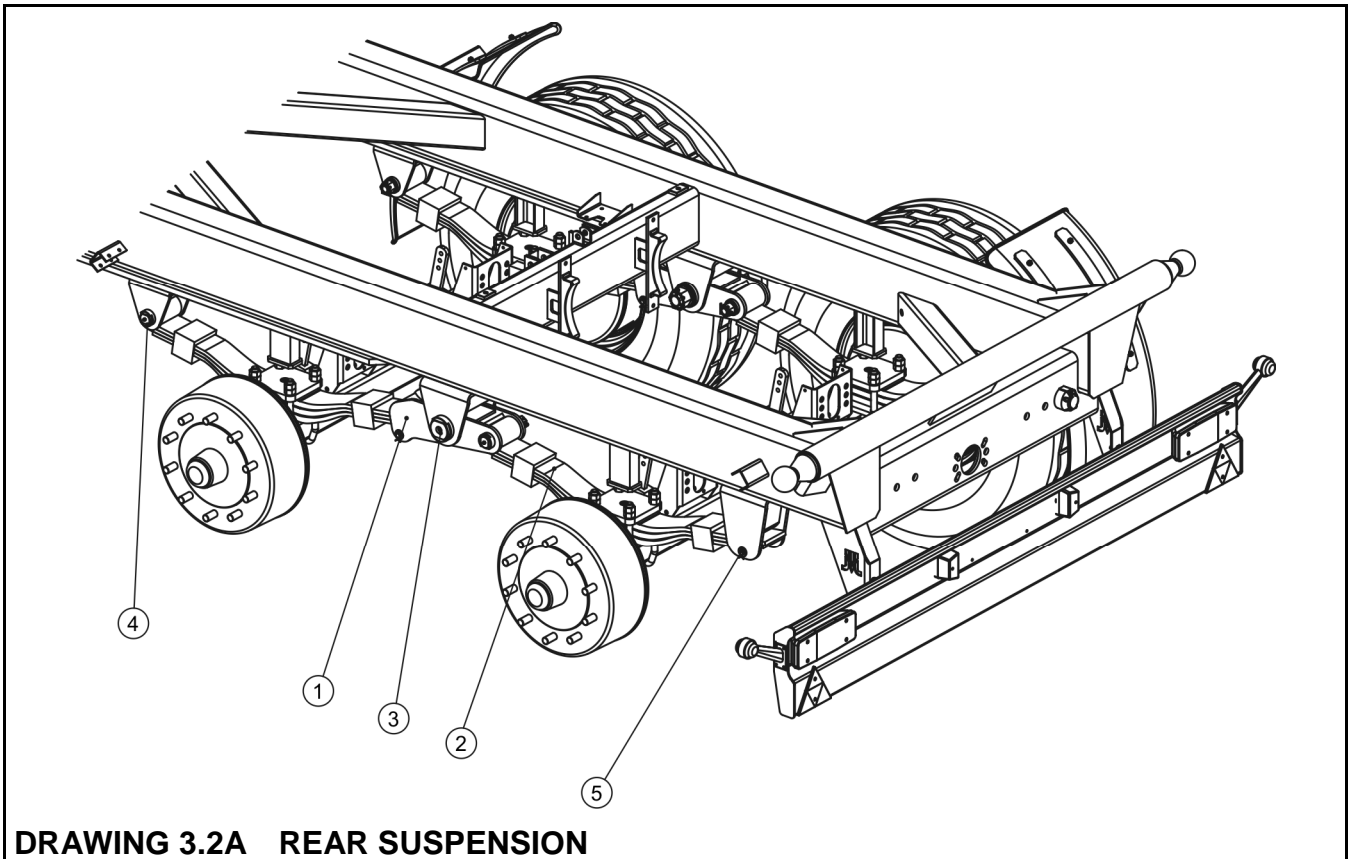

DRAWING 3.2A REAR SUSPENSION

(1) rocker arm, (2) taper leaf spring, (3) rocker arm pin, (4), (5) spring pins

3.3 LOAD BOX

Trailer's load box - Figure (3.3A) - consists of: upper frame (1), load box walls 800 mm (2), wall extensions 600 mm (3) and add additional accessories including fenced platform (4) and frame with canvas cover. Three different versions of walls (2) are available:

- No grain chute openings – standard,
- grain chute openings on the left side,
- grain chute openings on the right side,

The trailers of standard fittings include 600 mm wall extensions(3). Walls and wall extensions are connected with each other using linking cables (8).

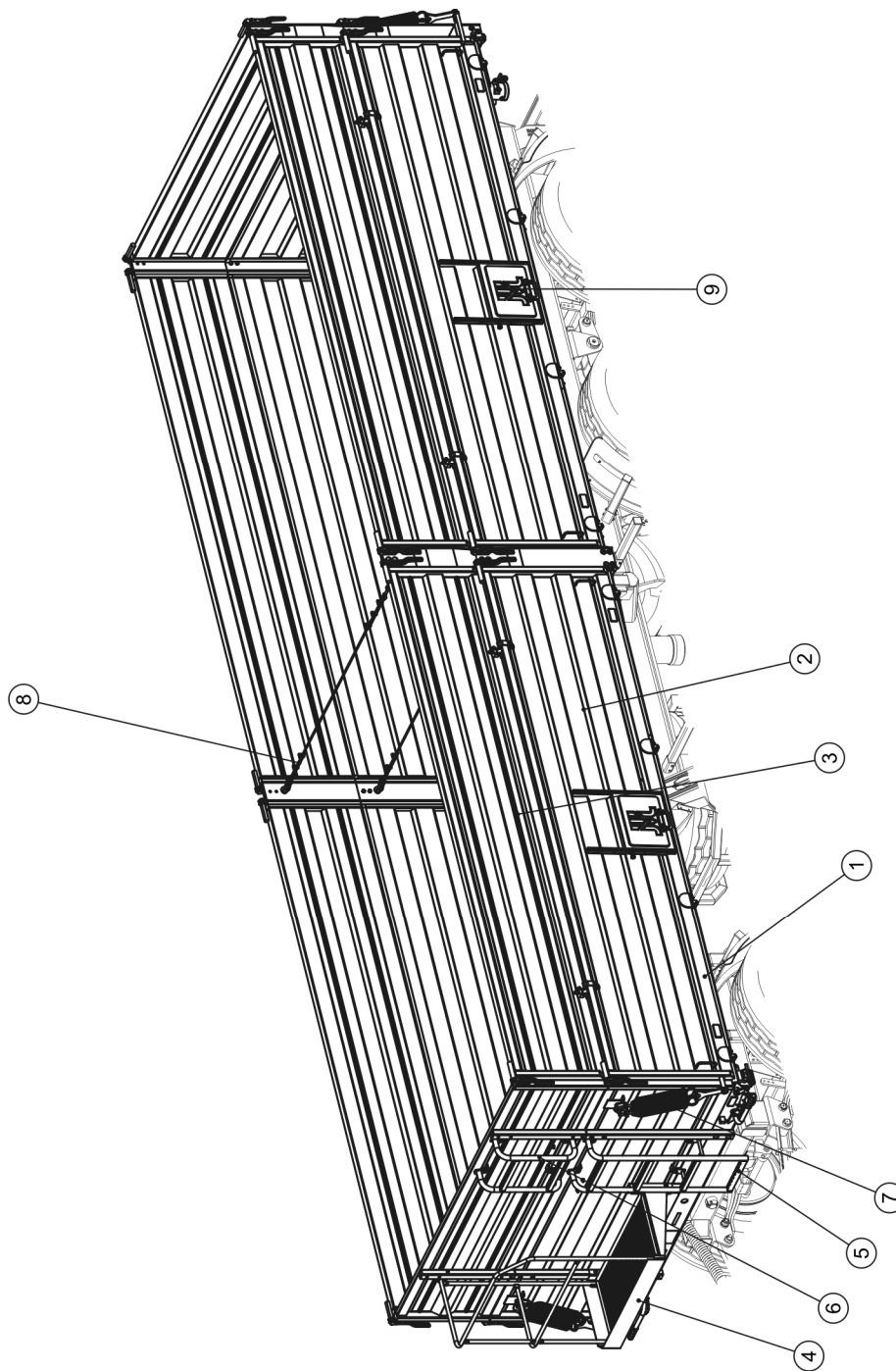

DRAWING 3.3A LOAD BOX

(1) upper frame, (2) load box walls, (3) wall extensions, (4) fenced platform, (5) front wall ladder, (6) front wall extension ladder, (7) side pull-off mechanism, (8) linking cable, (9) lateral grain chute

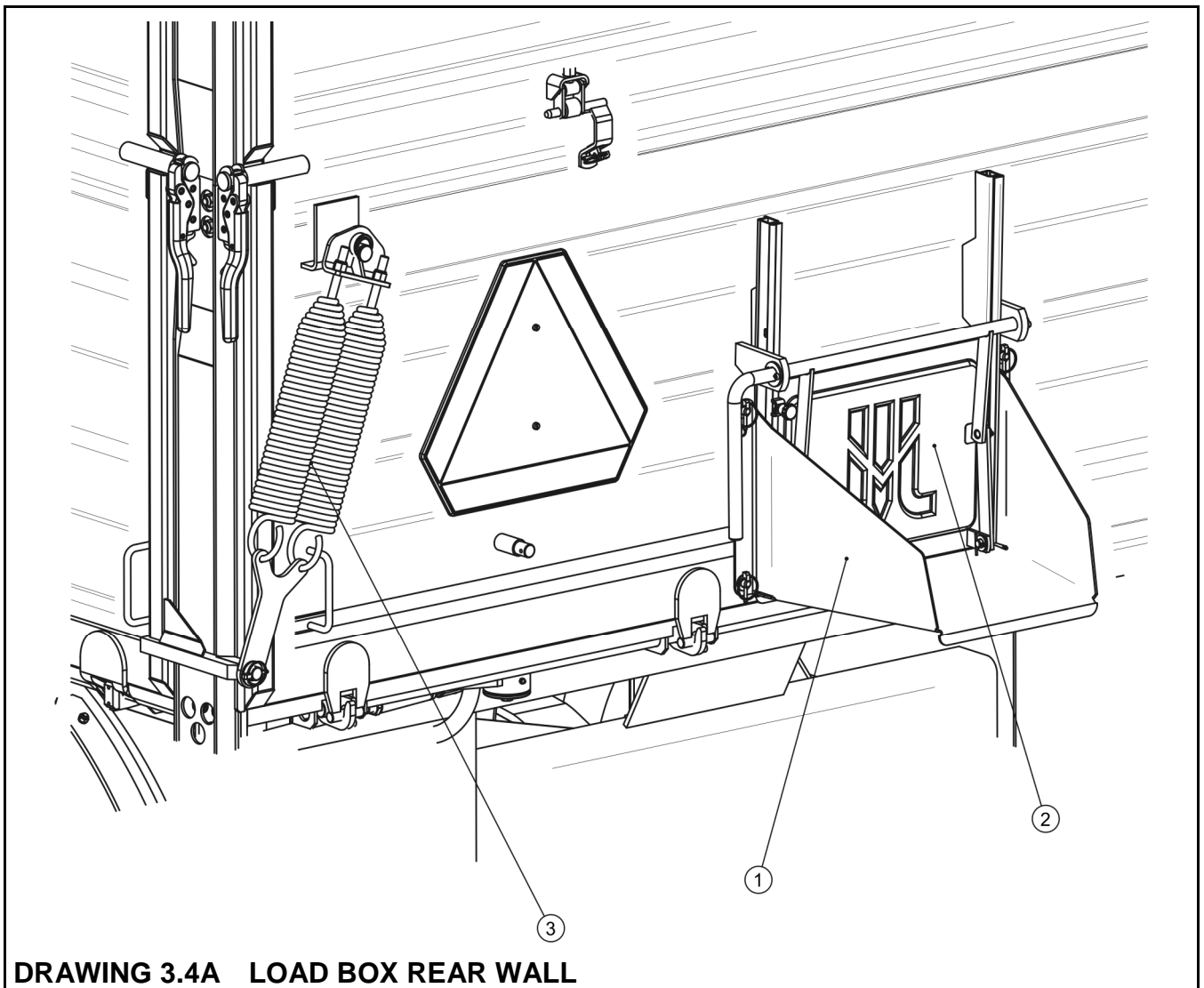

(1) grain chute, (2) slide gate, (3) rear wall pull-off mechanism

Upper frame is mounted on the lower frame and articulated sockets secured with pins, which are pivot points when tipping the load box in three directions

Wall ladder (5) and wall extension ladder (6) are mounted to the front wall and wall extension of the load box – figure (3.3A). Fenced platform (4) is mounted on the right side. Front wall (7) and rear wall (8) is installed on both sides of the load box – figure (3.4A).

Side walls (extensions) are mounted the using pins in front side wall (extension) brackets and brackets welded to rear and middle stakes. Slide lock (2) is installed in the rear wall – figure (3.4A), and chute (1), allowing more accurate unloading of loose materials.

3.4 WORKING BRAKE

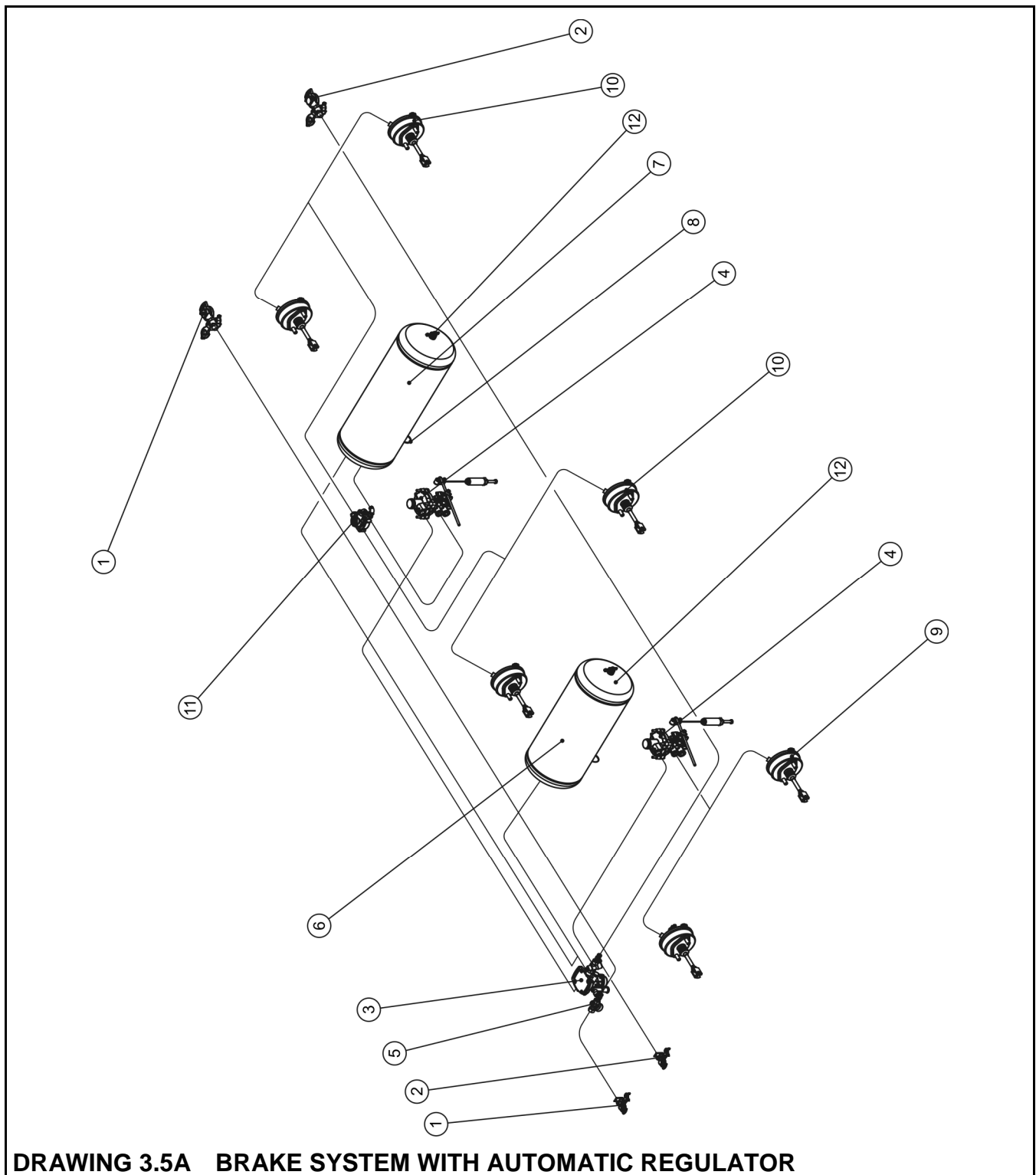

(1) supply conduit, (2) control connector, (3) control valve, (4) automatic brake force regulator, (5) air filter, (6) 40 L air tank, (7) 60 L air tank, (8) drain valve, (9) diaphragm actuator 30", (10) diaphragm actuator 24", (11) relay valve, (12) air tank to control connector

The trailer is equipped with double conduit pneumatic system with automatic brake force

regulator (3.5A)

Working brake is activated from the tractor driver's cab by pressing on the brake pedal in the tractor. The function of the control valve (3) - figure (3.5A) is the operation of the trailer's brakes simultaneously when tractor's brakes are applied. Furthermore, in case of an inadvertent disconnection of the conduit between the trailer and the tractor, the control valve will automatically activate trailer's brakes. Valve used in the system is equipped with a circuit causing the brakes to be applied when trailer is disconnected from the tractor. When compressed air conduit is connected to a tractor, the device automatically applying the brakes now changes its position to allow normal brake operation.

Automatic brake force regulator adjusts braking force depending on trailer load and does not require any attention of the trailers operator. When braking, compressed air from the control valve(3) flows through the regulator (4), and then is directed to brake ram cylinders (9), (10). The setting of brake force regulator lever mechanically connected with vehicle's axle depends on trailer's loaded. In a fully loaded trailer compressed air freely flows through the regulator exerting the highest braking force.

3.5 PARKING BRAKE

The parking brake is for immobilising trailer while standing motionless. The brake crank mechanism (3) – located on the left side of chassis frame - is connected with axle rudder bar using a steel cable (1). Rotation of the crank increases tension of the steel cable. Expander arms exert pressure on brake pads and cause the axle to brake. Prior to moving off, handbrake must be released - steel cable must hang loose.

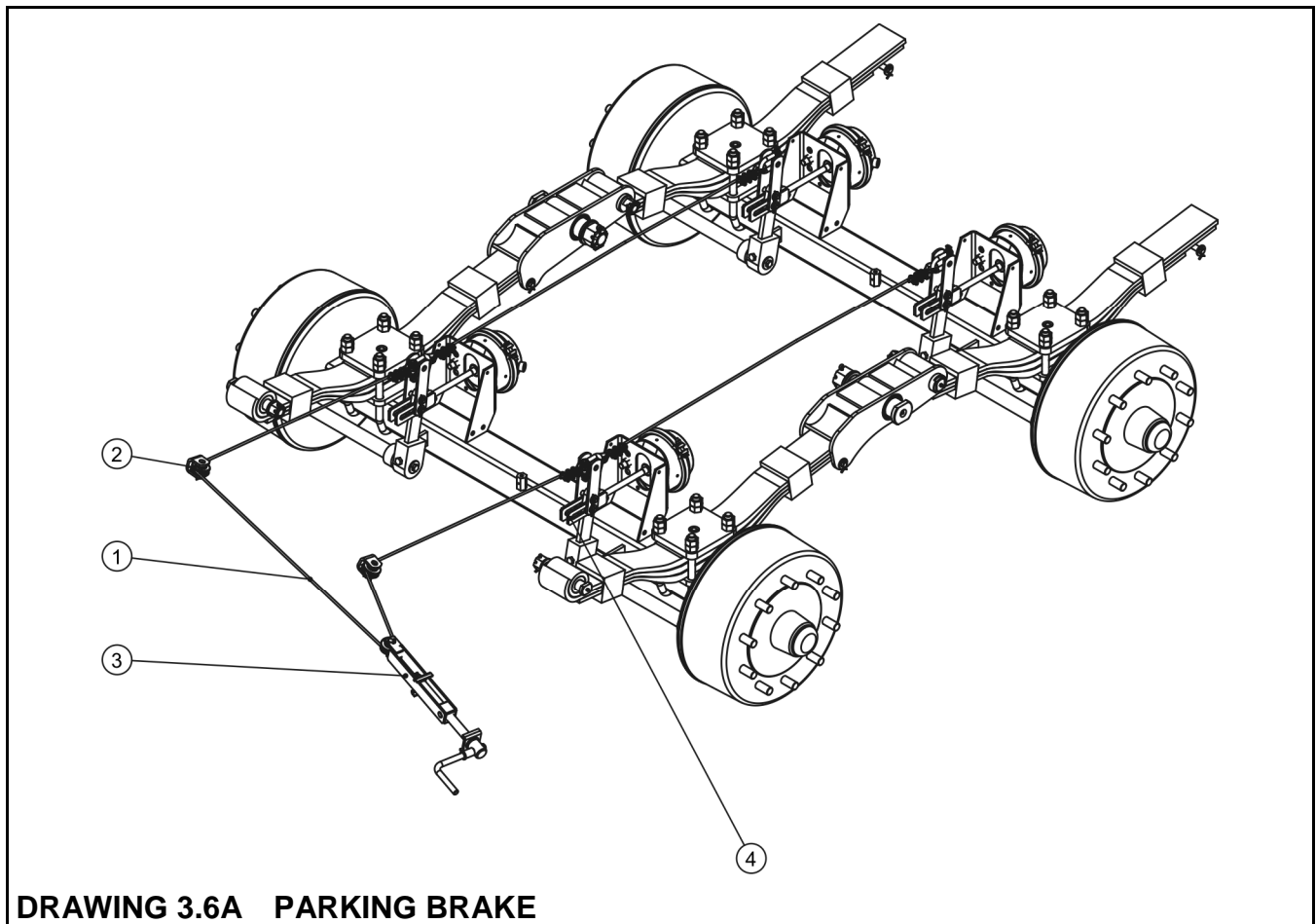

DRAWING 3.6A PARKING BRAKE

(1) steel cable, (2) guide rollers, (3) brake crank mechanism, (4) handbrake release

3.6 HYDRAULIC TIPPER SYSTEM

Hydraulic tipping system serves in automatic unloading of trailer by tipping the load box to the rear or sideways. The trailers hydraulic tipping system is supplied with oil from the tractor's hydraulic system. Hydraulic oil manifold of the tractor's external hydraulic system is used to control the load box tipping mechanism.



ATTENTION!

Cut-off valve (3) – figure (3.7A) limits the tipping angle of the load box when tipped to the sides. The length of the control cable (4) controlling this valve is factory adjusted by the manufacturer and must not be changed when the trailer is used.

The trailer system consists of two independent circuits:

- circuit (A) - to supply the trailer's hydraulic ram cylinders,
- circuit (B) - to supply of the second trailer's hydraulic ram cylinder, if two trailers are

hitched to the tractor.

Three-way valve (7) – (3.7A) is used to activate these circuits. This valve's lever can be placed in two positions:

- 1 - trailer's tipping circuit opened - circuit (A),
- 2 - second trailer's tipping circuit opened – circuit (B).

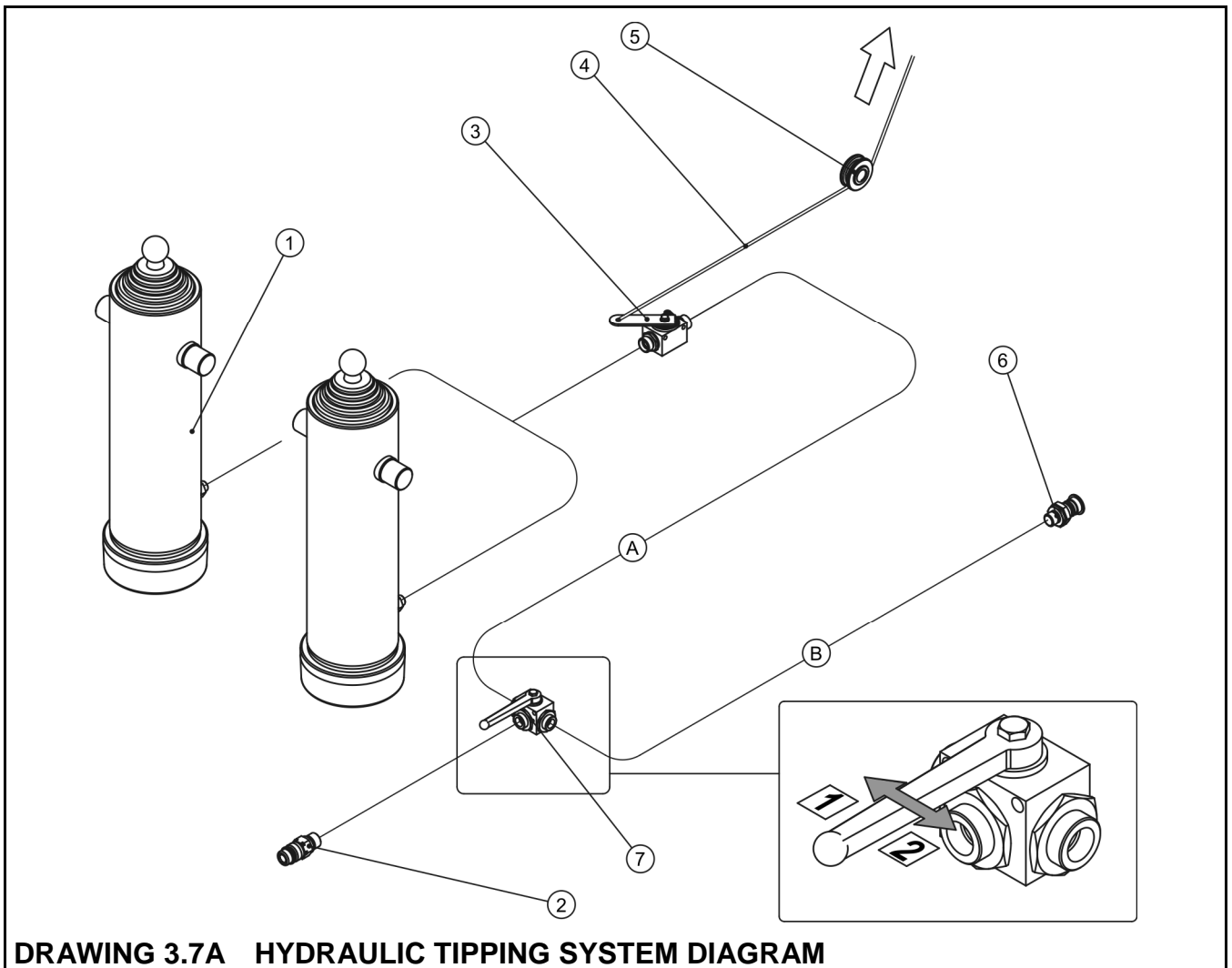

(1) telescopic cylinder, (2) plug, (3) cut-off valve, (4) control cable, (5) guide roller, (6) socket, (7) three-way valve

3.7 ELECTRICAL SYSTEM, WARNING SIGNS AND INDICATORS

The trailer's electrical system is designed for supply of 12 V DC. Connection of the trailer's electrical system with the tractor should be made through an appropriate connection lead that is part of the trailer's standard equipment.

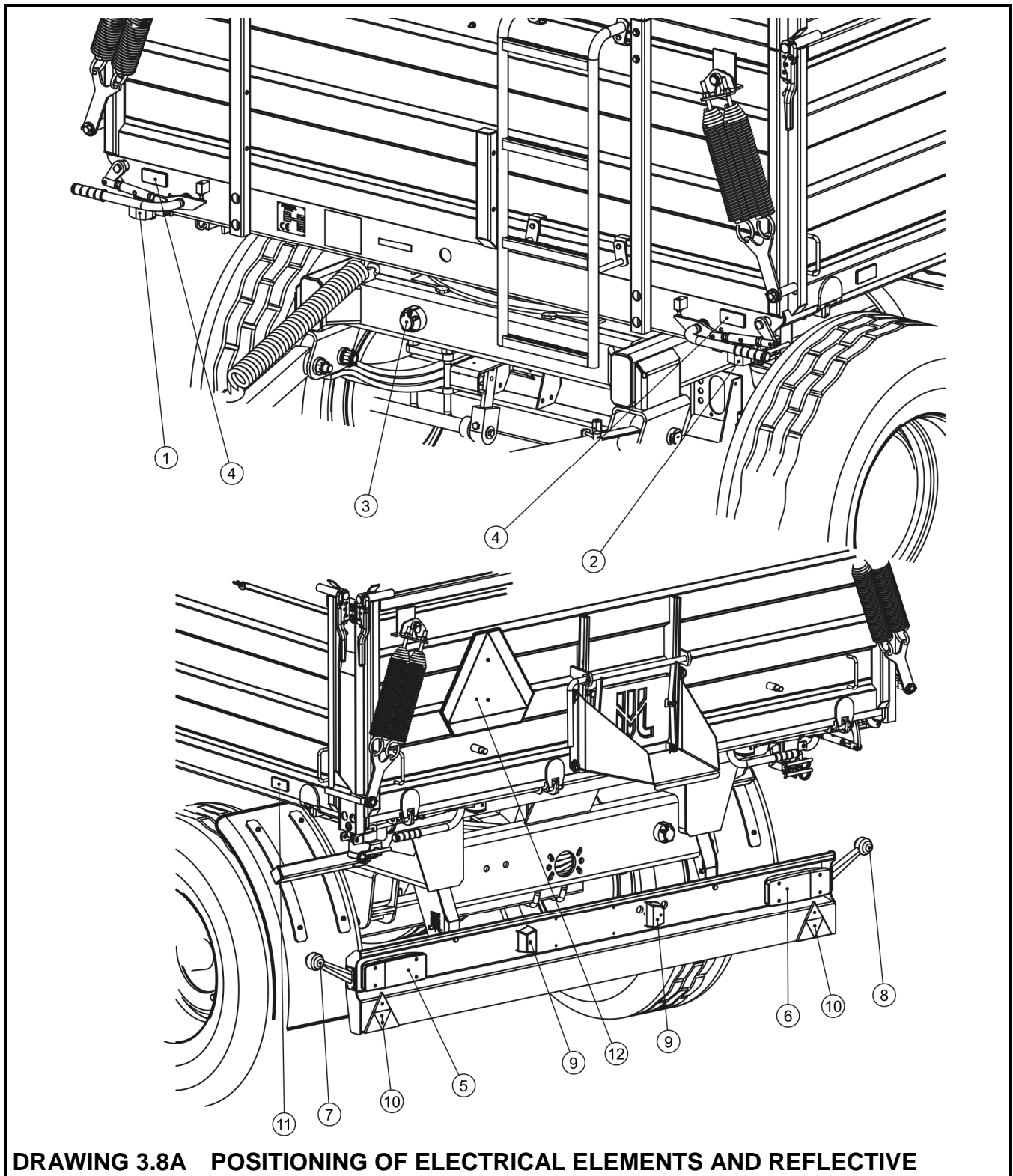

DRAWING 3.8A POSITIONING OF ELECTRICAL ELEMENTS AND REFLECTIVE

(1),(2) front position lamp, (3) 7-pin socket, (4) white reflective light (5), (6) rear light combination group, (7), (8) clearance light, (9) license plate light, (10) rear reflective triangle, (11) orange lateral reflective light, (12) slow-moving vehicle warning sign

Lateral clearance lamps are available as additional accessories. Positioning of electrical

components and reflective lights is shown on figure (3.9A). Figure (3.10A) presents electrical system diagram including additional accessories (lateral clearance lights).

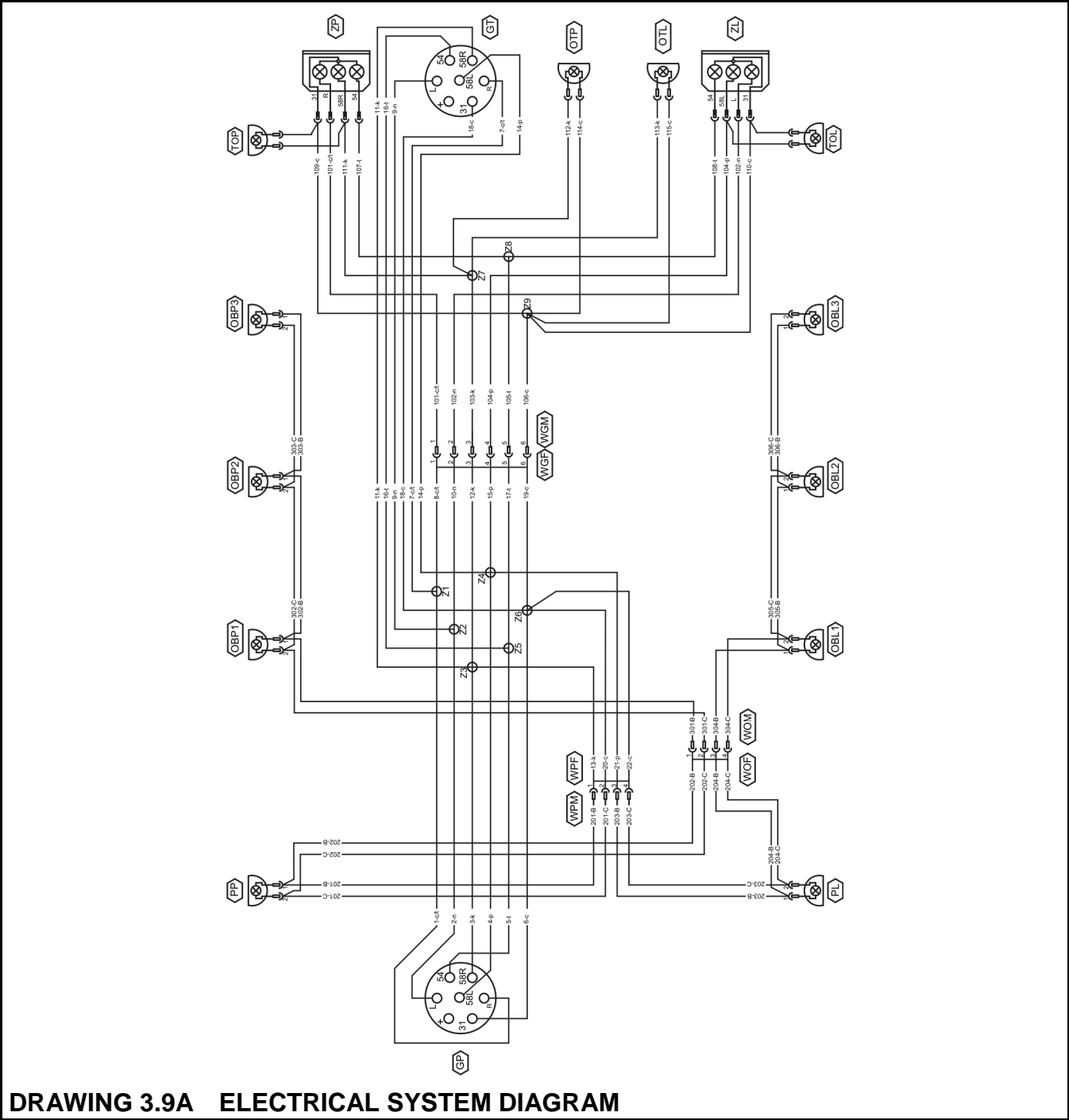

DRAWING 3.9A ELECTRICAL SYSTEM DIAGRAM

(ZP), (ZL) rear lamp group, (TOP), (TOL) rear clearance light, (GP), (GT) seven-pin socket, (OTP), (OTL) license plate light, (PP), (PL) front position lamp, (OBL), (OBP) lateral clearance light

SECTION

4

CORRECT USE

PREPARING FOR WORK BEFORE FIRST USE
CHECKING THE TRAILER'S TECHNICAL CONDITION
ATTACHING TO TRACTOR
LOADING
TRANSPORTING LOADS
UNLOADING
DISCONNECTING FROM TRACTOR
PROPER USE AND MAINTENANCE OF TYRES

4.1 PREPARING FOR WORK BEFORE FIRST USE

The trailer is supplied to the user in a completely assembled state and does not require additional mounting operations of machine sub-assemblies. The manufacturer guarantees that the trailer is fully operational and has been checked according to quality control procedures and is ready for normal use. This does not release the user from an obligation to check the machine's condition prior to purchasing and before first use.

Prior to connecting to the tractor, machine operator must verify the trailer's technical condition. In order to do this:

- the user must familiarise himself with the content of these instructions and observe all recommendations
- immobilise trailer with parking brake,
- check condition of paint coatings, traces of corrosion or mechanical damage (crushing, piercing, bending or breaking of minor elements),
- Check if side walls open correctly, locks interlock properly, there are no missing cotter pins,
- Check if tipping pins are inserted and correctly interlocked (pin lug should be vertical, cotter pin installed),
- check air pressure in tyres and check correct tightening of wheel nuts,
- check if the drawbar is correctly installed,
- Check the technical condition of canvas cover, clips fastening canvas belts and if the frame is assembled correctly.
- Drain water from pneumatic system -- see section 5.

If all the above checks have been performed and there is no doubt as to the trailer's good technical condition, it should be hitched to tractor (4.3). After connection of brake system conduits and hydraulic tipping system conduit, the correct operation of individual systems should be checked with inspection of systems and hydraulic cylinders with regard to seals and tightness. Further use of the trailer, is not permitted, if there are any leaks from hydraulic systems or if the brake systems are unreliable. If any faults are detected they must be

identified and rectified. If a fault cannot be rectified or the repair could void the guarantee, please contact retailer for additional clarifications.



ATTENTION!

Non-adherence to the recommendations contained in the instructions or improper use of trailer may cause damage to the machine.

The technical condition prior to starting use may not give rise to any reservation.

4.2 CHECKING THE TRAILER'S TECHNICAL CONDITION

When preparing the trailer for normal use, check individual elements according to guidelines presented in table (4.1).

TABLE 4.1 TECHNICAL INSPECTION SCHEDULE

DESCRIPTION	SERVICE OPERATION	FREQUENCY
Check technical condition of tyres and tyre pressure,	Visually inspect the tyres and check if they are properly inflated.	Before each use
Correct operation of lights and indicators.	After hitching trailer to the tractor activate in sequence individual lights, check if all reflective lights are installed, check if slow-moving vehicle warning sign is in place.	
Operation of brake system	Attach trailer to the tractor and test the brakes after moving off.	
Operation of hydraulic tipping system	Check operation and tightness of hydraulic systems during tipping of load box	
Check technical condition of tyres and tyre pressure,	Check the condition of tyre tread, lateral surfaces, wheel rim and if necessary inflate the tyres up to recommend pressure	Every month
Check if the nuts and bolts securing drawbar and other nut and bolt connections are properly tightened,	Torque values should be according to table (5.5).	Every three months

DESCRIPTION	SERVICE OPERATION	FREQUENCY
Lubrication	Lubricate elements according to guidelines presented in section "Lubrication".	According to table (5.4)
Degree of tightening of road wheel nuts	Torque values should be according to table (5.5).	According to section 4.8 "Proper use and maintenance of tyres"

ATTENTION!



The trailer must not be used when not in working order.

Prior to connecting individual system conduits the user must familiarise himself with the content of the tractors operating instructions and observe all manufacturer's recommendations.

4.3 ATTACHING TO TRACTOR

Trailer may only be hitched to tractor equipped with a hitch, capable of towing 27,000 kg.

DANGER



When attaching, there must be nobody between the trailer and the tractor. when attaching the trailer, tractors driver must exercise caution and make sure that nobody is present in the hazard zone.

Hitching trailer to agricultural tractor shall be performed according to the sequence described below:

- immobilise trailer with parking brake,
- place tractor sufficiently near to trailer,
- Adjust drawbar height, if necessary. Precise setting of drawbar eye can be achieved by adjusting drawbar spring (1) tension by moving bracket (2) - figure (4.1A),

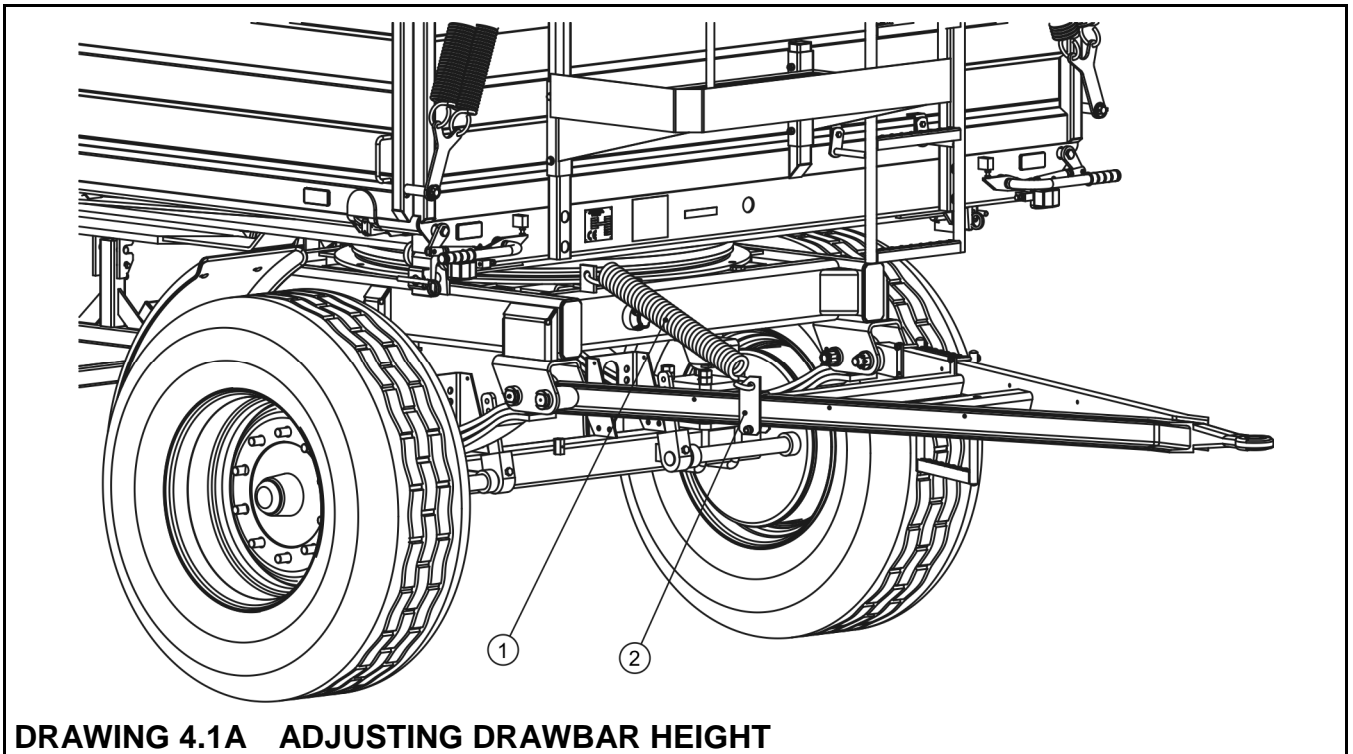

DRAWING 4.1A ADJUSTING DRAWBAR HEIGHT

(1) tension spring, (2) bracket

- reverse tractor, connect drawbar eye with appropriate tractor hitch, secure the hitch against inadvertent disconnection of the trailer
- connect electrical leads to the tractor as well as braking and tipping system conduit tubes to appropriate tractor sockets,
- release parking handbrake, turning brake mechanical crank anticlockwise.



ATTENTION!

Do NOT travel with trailer which has an unreliable brake, lighting or signalling system.

When turning, conduit connection tubes must hang loosely and not become tangled with moving elements of trailer and tractor.

Pneumatic brake systems are equipped with connectors, whose safety caps, are made from coloured plastic. The colours of these elements correspond to the colours of the connection sockets in the tractor (yellow, red).

4.4 LOADING

Before beginning loading it is necessary to make certain that the load box side walls and slide gates are properly closed and secured. The trailer must be positioned to travel forwards and be hitched to the tractor. Loading should only take place, when trailer is placed on flat level surface and hitched to tractor. If the trailer is equipped with canvas cover, it should be rolled to the right. If load does not exert pressure on the side walls or extension walls, the linking cable can be disengaged. In other cases it must be attached to middle stakes of walls and wall extensions. Walls can be damaged if there is no linking cable.

Load should be distributed evenly in load box. Depending on type of load, it is necessary to use the appropriate equipment (crane, loader, foreloader etc.). Loading should be carried out by a person experienced in this type of work and having appropriate authorisation for operating equipment (if required). When loading goods on pallets pay special attention to load distribution on the platform. Pallets must be secured against the displacement on the platform. Pallets must not be stacked in layers.

TABLE 4.2 GUIDELINE WEIGHTS VOLUME OF SELECTED LOADS

TYPE OF MATERIAL	VOLUME WEIGHT kg/m ³
Root crops: raw potatoes steamed crushed potatoes dried potatoes sugarbeet - roots fodderbeet - roots	700 - 820 850 - 950 130 - 150 560 - 720 500 - 700
Organic fertilisers: old manure mature manure fresh manure compost dry peat	700 - 800 800 - 900 700 - 750 950 – 1 100 500 - 600
Mineral fertilisers: ★ ammonium sulphate	800 - 850

TYPE OF MATERIAL	VOLUME WEIGHT kg/m ³
potash salt	1,100 – 1 200
superphosphate	850 – 1 440
basic slag phosphate	2,000 – 2 300
potassium sulphate	1,200 – 1 300
kainite	1,050 – 1 440
milled lime fertiliser	1,250 - 1 300
Building materials: ★	
cement	1,200 – 1 300
dry sand	1,350 – 1 650
wet sand	1,700 – 2 050
solid bricks	1,500 – 2 100
hollow bricks	1,000 – 1 200
stones	1,500 – 2 200
soft wood	300 - 450
hard sawn timber	500 - 600
impregnated timber	600 - 800
steel structures	700 - 7000
milled burnt lime	700 - 800
cinders	650 - 750
gravel	1,600 – 1 800
straw litter and bulk feeds	
meadow hay dried in the swath	10 - 18
hay wilted in the swath	15 - 25
hay in gathering trailer (dry wilted)	50 - 80
wilted cut hay	60 - 70
dry baled hay	120 - 150
wilted baled hay	200 - 290
stored dry hay	50 - 90
stored cut hay	90 - 150
clover (lucerne) wilted in the swath	20 - 25
clover (lucerne) cut wilted on trailer	110 - 160
clover (lucerne) wilted on gathering trailer	60 - 100

TYPE OF MATERIAL	VOLUME WEIGHT kg/m ³
dry stored clover	40 - 60
cut dry stored clover	80 - 140
dry straw in round bales	8 - 15
damp straw in round bales	15 - 20
cut damp straw in bulk trailer	50 - 80
cut dry straw in bulk trailer	20 - 40
cut dry straw in gathering trailer	50 - 90
cut dry straw in stack	40 - 100
baled straw (lightly crushed)	80 - 90
baled straw (heavily crushed)	110 - 150
cereal mass in round bales	20 - 25
cut cereal mass in bulk trailer	35 - 75
cut cereal mass in gathering trailer	60 - 100
green fodder in swath	28 - 35
cut green fodder in bulk trailer	150 - 400
green fodder in gathering trailer	120 - 270
fresh beet leaves	140 - 160
cut fresh beet leaves	350 - 400
beet leaves in gathering trailer	180 - 250
concentrated feeds and mixed feeds:	
stored chaff	200 - 225
pressed cake	880 – 1 000
milled dry feed	170 - 185
mixed feeds	450 - 650
mineral mixtures★	1,100 – 1 300
ground oats	380 - 410
wet sugarbeet pulp	830-1000
pressed sugar beet pulp	750 - 800
dry sugarbeet pulp	350 - 400
bran	320 - 600
bonemeal	700 – 1 000
pasture salt★	1,100 – 1 200

TYPE OF MATERIAL	VOLUME WEIGHT kg/m ³
molasses	1,350 – 1 450
silage (pit silo)	650 – 1 050
hay silage (tower silo)	550 - 750
Seeds and grains:	
beans	750 - 850
mustard	600 - 700
peas	650 - 750
lentils	750 - 860
runner beans	780 - 870
barley	600 - 750
clover	700 - 800
grass	360 - 500
maize	700 - 850
wheat	720 - 830
oil seed rape	600 - 750
linseed	640 - 750
lupins	700 - 800
oats	400 - 530
lucerne	760 - 800
rye	640 - 760
Others:	
dry soil	1,300 – 1 400
wet soil	1,900 – 2 100
fresh peat	700 - 850
garden soil	250 - 350

Source: "Technology of machine work in agriculture", PWN, Warszawa 1985

★ - building materials, mineral fertilisers and mineral mixtures cause damage to trailer construction and/or paint coating and cause the creation of corrosion points

With regard to the various density of materials, using the total load box capacity may cause exceeding permissible carrying capacity of the trailer. Guideline specific weight of selected

materials shown in table (4.2). It is necessary to pay particular attention not to overload the trailer.

Light materials with a large volume, maybe loaded even above the edge of the load box extension walls paying special attention to trailer stability. Regardless of the type of load carried, the user is obliged to secure it in such a manner that the load is unable to spread and cause contamination of the road.

Construction materials can be transported using the trailer, provided the load box is properly prepared. In order to do that lay thick plywood, hard particle board, thick planks or other materials of similar properties on the load box platform. Side walls and optionally load box extension walls should be protected in a similar manner. Non-compliance with these requirements could lead to dents in the load box platform or its walls, scratching of painted surfaces and could give rise to ingress of corrosion. Non-compliance with the instructions provided could invalidate the guarantee.

Mineral fertilisers and other materials, which by having contact with painted or steel surfaces may cause damage, are recommended to be carried in sealed packing (sacks, boxes, drums, barrels etc.). After unloading the load box should be thoroughly cleaned using strong water jet.

If the transported materials exert high local pressure on the load box platform it should be protected against damage using thick planks, plywood or other materials of similar properties.

Oilseed rape or seeds of other plants of very small size can be transported provided the load box is properly sealed in places where gaps are a bigger than the seed diameter. Profiled rubber seals, silicone sealers, plastic wrap, rope or textile materials are recommended materials to provide sealing of the load box.



ATTENTION!

Do NOT exceed permissible load weight of trailer because this may cause danger to road traffic and cause damage to the machine.

4.5 TRANSPORTING LOADS

When travelling on public or private roads, respect the road traffic regulations, exercise caution and prudence. Listed below are the key guidelines for driving the tractor and trailer combination.

- Before moving off make sure that there are no bystanders, especially children, near the trailer or the tractor. Take care that the driver has sufficient visibility.
- Make sure that the trailer is correctly attached to the tractor and tractor's hitch is properly secured.
- The trailer must not be overloaded, loads must be uniformly distributed so that the maximum permissible axle loads are not exceeded. The trailer's maximum carrying capacity must not be exceeded as this can damage the trailer and pose a risk to the operator or other road users.
- Permissible design speed and maximum speed allowable by road traffic law must not be exceeded. The towing speed should be adapted to the current road conditions, load carried by the trailer, road surface conditions and other relevant conditions.
- Trailer may be towed on slopes of up to 8° and unloading must take place only on a level surface.
- When not connected to the tractor, the trailer must be immobilised using parking brake and possibly also with wedges or other objects without sharp edges placed under the front and back wheels. Do NOT leave unsecured trailer. In the event of trailer malfunction, pull over on the hard shoulder avoiding any risk to other road users and position reflective warning triangle according to traffic regulations.
- When travelling on public roads trailer must be marked with a slow-moving vehicle warning sign attached to the rear wall of load box, if the trailer is the last vehicle in the group. While driving on public roads the trailer must be fitted with a certified or authorised reflective warning triangle. When driving, comply with all road traffic regulations, indicate an intention to turn using indicator lamps, keep all road lights and indicator lights clean at all times and ensure they are in good condition. Any damaged or lost lamps or indicator lights must be immediately repaired or replaced.
- Avoid ruts, depressions, ditches or driving on road side slopes. Driving across such obstacles could cause the trailer or the tractor to suddenly tilt. This is of special

importance because loaded trailer's centre of gravity is higher, which reduces safety. Driving near ditches or channels is dangerous as there is a risk of the wheels sliding down the slope or the slope collapsing.

- Speed must be sufficiently reduced before making a turn or driving on an uneven road or a slope.
- When driving, avoid sharp turns especially on slopes.
- Please note that the braking distance of tractor and trailer combination is substantially increased at higher speeds and loads carried in the trailer.

ATTENTION!



Prior to moving off with the trailer hitched, check the following:

- pins connecting the load box with the lower frame are secured against falling out,
- side wall hinge pins are protected against falling out.

4.6 UNLOADING

The trailer is equipped with hydraulic tipping system and suitable frame structure and the load box allowing tipping sideways and to the rear. Tipping off the load box is controlled from driver's cab using external tractor hydraulic system manifold. Unloading trailer is performed in the following sequence:

- tractor and trailer must be placed to drive forwards on flat ground,
- immobilise tractor and trailer with parking brake,
- Tipping pins (connecting load box and lower frame) should be placed and properly interlocked on the side which will be used to unload. Individual sockets are designed so it is impossible to place them on the opposite diagonal side of the load box which would damage the trailer,
- Open appropriate closures chute sliding gates (depending on the direction in which unloading should take place). When opening take special care because load may exert a great pressure on the walls,
- Using the manifold lever in the operator's cabin to initiate tipping of the load box,

- after unloading a lot where there is an old box, clean the residual material from the load box edge, the walls and wall extensions,
- close and secure the walls and wall extensions or chute opening,
- before moving off make sure that tipping pin are in correct position, i.e. with the handle facing downward and secured with cotter pin - see figure (4.2A).

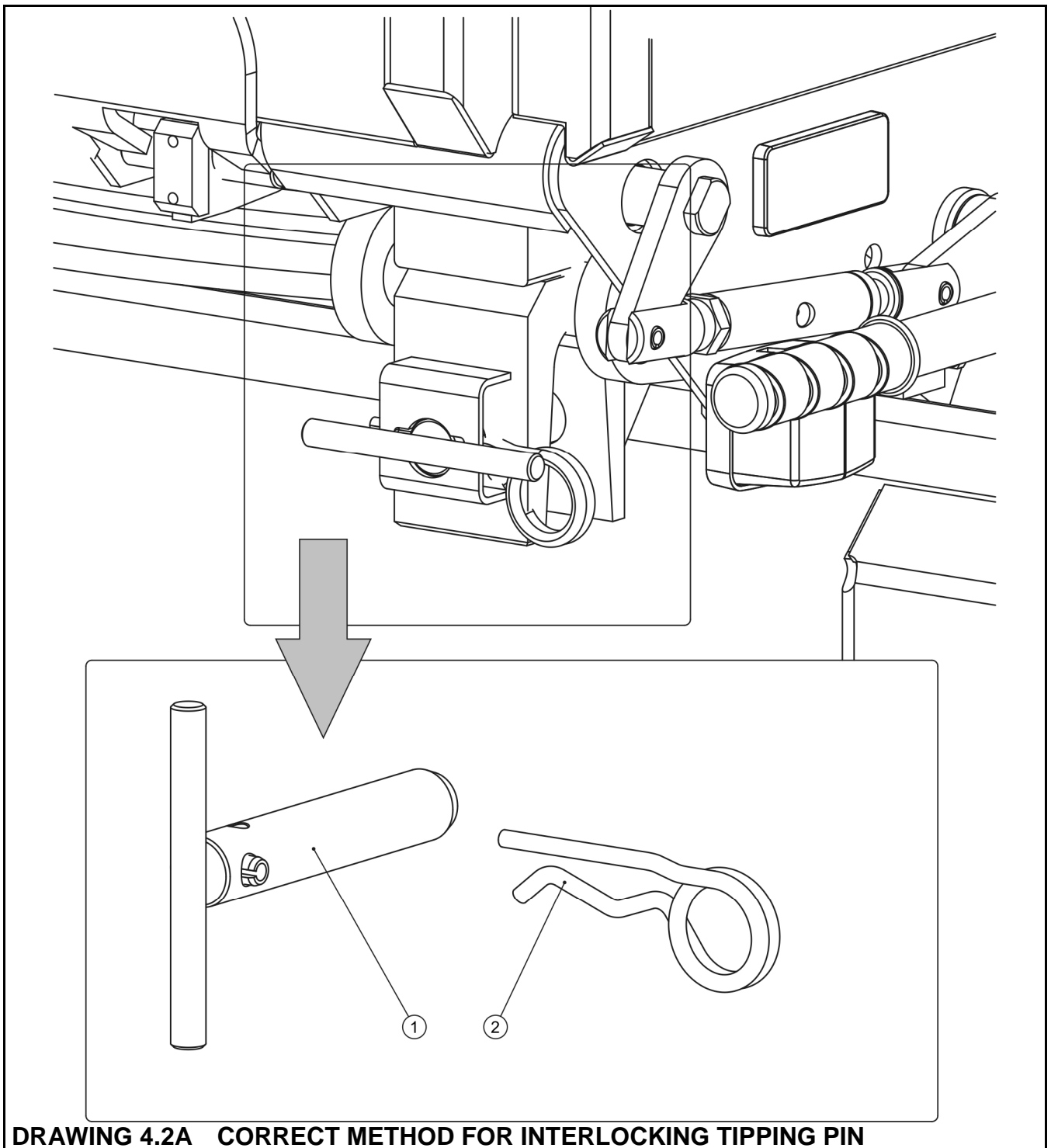

DRAWING 4.2A CORRECT METHOD FOR INTERLOCKING TIPPING PIN

(1) tipping pin (2) securing cotter pin

Rear load box wall is equipped with chute slide gate (1) and chute opening (2) (additional accessory) – figure (4.3A) which is used for unloading of loose materials. Chute design allows very accurate dosing of the material to packaging (sacks, boxes etc). The opening gap can be controlled using a lever (4). In order to do that loosen the interlocking bolt (3), open the slide as required and interlock using the bolt. When unloading through the chute do not open wall locks or wall extension locks and tipping of the load box must be done very slowly and without jerking. Raising the load box quickly will exert large pressure on the rear part of the load box due to displacement of the carried material and could compromise trailer's stability.

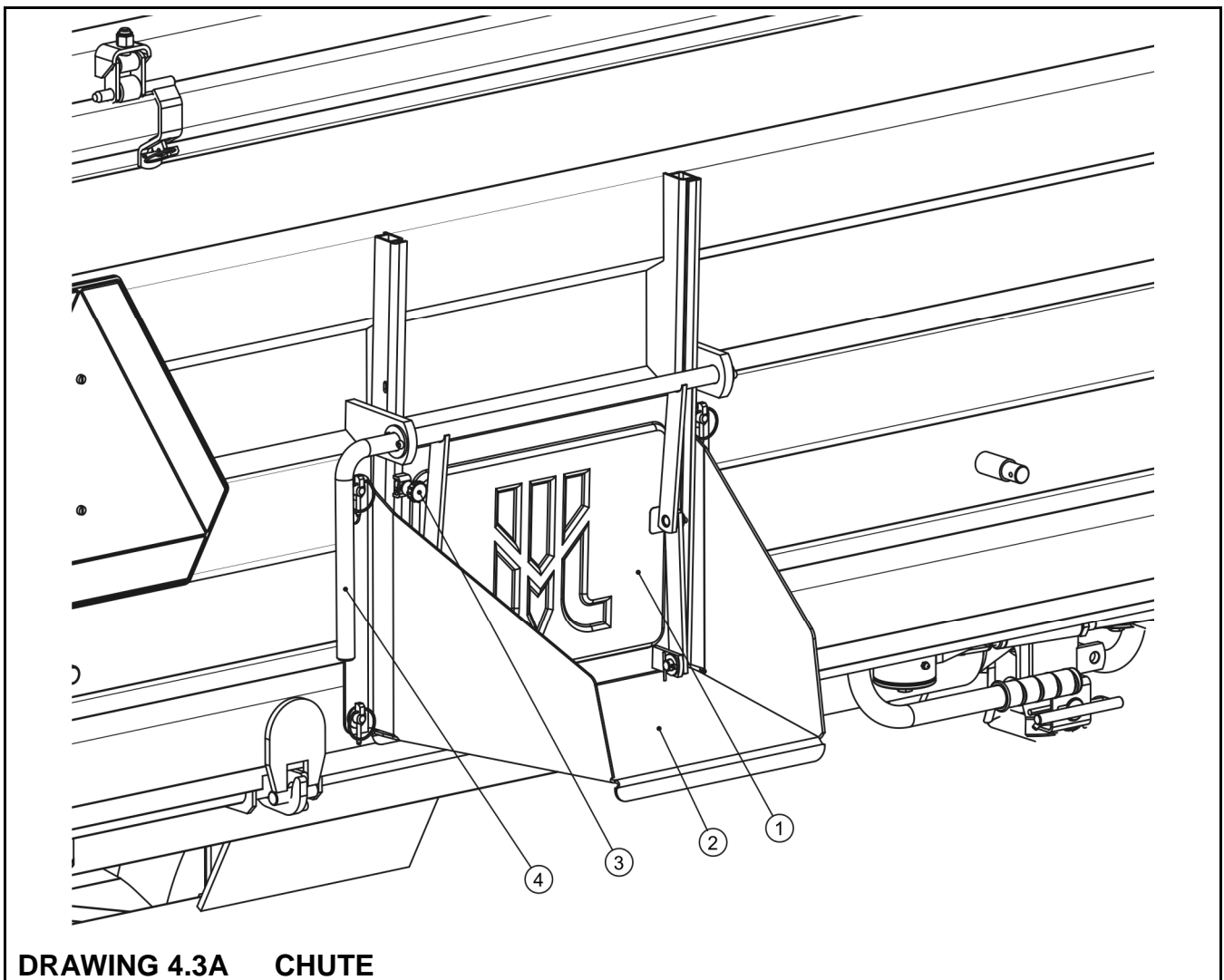

(1) chute slide gate, (2) chute, (3) interlocking bolt, (4) lever

Unloading of loose materials through chute openings in lateral walls (additional accessory) should be performed according to procedures described above.

DANGER

Tipping the load box must be done on hard and level ground.

Use only original pins with a handle and securing cotter pin. Using third-party pins could damage the trailer. Tipping pins must be correctly interlocked.

When opening load box side wall locks take particular care, because of the pressure of the load on the wall.

When opening and closing the rear grain chute gate or the walls take particular care to avoid crushing fingers.

Bulk materials loaded in excess of 1 m can be unloaded by tipping the load box to the rear only.

Ensure that during unloading nobody is near tipped load box or load material pouring out.

Tipping may only be performed when trailer is hitched to tractor.

Do NOT tip load box in strong gusty winds conditions.

Do NOT move off or drive when load box is raised.

Take particular care while unloading near electric power lines.



4.7 DISCONNECTING FROM TRACTOR

In order to disconnect the trailer from the tractor perform the following:

- stop tractor, immobilise trailer with parking brake and if needed place wedges under wheels,
- disconnect from the tractor all electrical leads as well as hydraulic tipping and braking system conduits tubes and protect ends of these conduits against contamination,
- Disconnect drawbar from the tractor's hitch and move the tractor forward.

4.8 PROPER USE AND MAINTENANCE OF TYRES

- When working on the tyres, wedges or other objects without sharp edges should be placed under the wheels of the trailer to prevent it from rolling. The wheel can be taken off only when the trailer is not loaded.
- Repair work on the wheels or tyres should be carried out by persons trained and entitled to do so. This work should be carried out using appropriately selected tools.
- After removing a wheel, always check how firmly the nuts are screwed in. Individual

checks should be made after the first use, after the first journey with a load and then every 6 months. The above actions should be repeated individually if a wheel has been removed from the wheel axle.

- Regularly check and maintain correct pressure in tyres according to instructions (especially if trailer is not used for a longer period).
- Pressure and tyres should be also checked after the whole day of intensive work. Please note that higher temperatures could raise tire pressure by as much as 1 bar. At high temperatures and pressure reduced load or speed.
- Do not release air from warm tyres to adjust the pressure or the tyres will be underinflated when temperatures return to normal.
- Protect valves using suitable caps to avoid soiling.
- Do not exceed the trailer's maximum design speed.
- When trailer is operated all day, stop working for a minimum of one hour in the afternoon.
- Adhere to 30 minutes rest for cooling tyres after driving 75 km or after 150 minutes continuous travel depending on which occurs first.
- Avoid potholes, sudden manoeuvres or high speeds when turning.

SECTION

5

TECHNICAL MAINTENANCE

INSPECTION AND REGULATION OF WHEEL AXLE BEARINGS

REGULATION OF MAIN BRAKES

REGULATION OF MAIN BRAKES

PNEUMATIC SYSTEM OPERATION

HYDRAULIC SYSTEM OPERATION

LUBRICATION

INSTALLATION AND DISASSEMBLY OF THE FRAME AND CANVAS COVER

INSTALLATION AND DISASSEMBLY OF EXTENSION WALLS

ABSORBER SPRING SYSTEM MAINTENANCE

STORAGE

TRAILER PREPARATION FOR END OF SEASON

TIGHTENING TORQUE FOR NUT AND BOLT CONNECTIONS

LIST OF BULBS

5.1 INSPECTION AND REGULATION OF WHEEL AXLE BEARINGS

In newly purchased trailer, after covering a distance of 100 km, while during further use – after 6 months of vehicle use check and regulate wheel axle bearings when needed. Worn or damaged bearing should be replaced. Inspection of these elements should be conducted according to instructions below.

- Hitch empty (without load) trailer to tractor, place blocking wedges under trailer wheels and raise wheels in succession using the appropriate lifting jack. The lifting jack should be placed under the axle between U crews fixing absorber springs to the axle (figure (5.2A)). Make certain that the trailer will not move during inspection of the bearing.
- Turning the wheel slowly in both directions check that movement is smooth and that the wheel rotates without excessive resistance.
- Turn the wheel so that it rotates very quickly, check that the bearing does not make any unusual sounds.
- Grasp wheel above and below and try to feel any slack play, this may equally be checked with the aid of a jack placed under the wheel supported on the floor/ground.

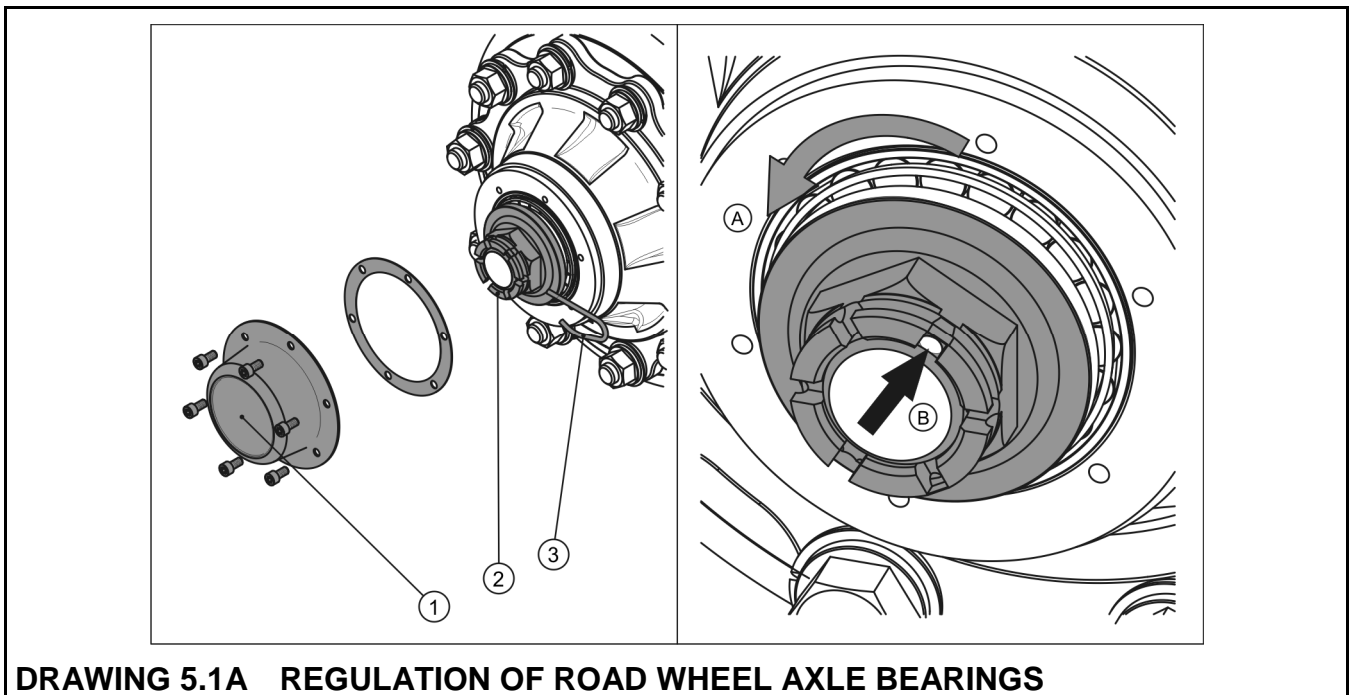

DRAWING 5.1A REGULATION OF ROAD WHEEL AXLE BEARINGS

(1) hub cover, (2) castellated nut, (3) securing split cotter pin

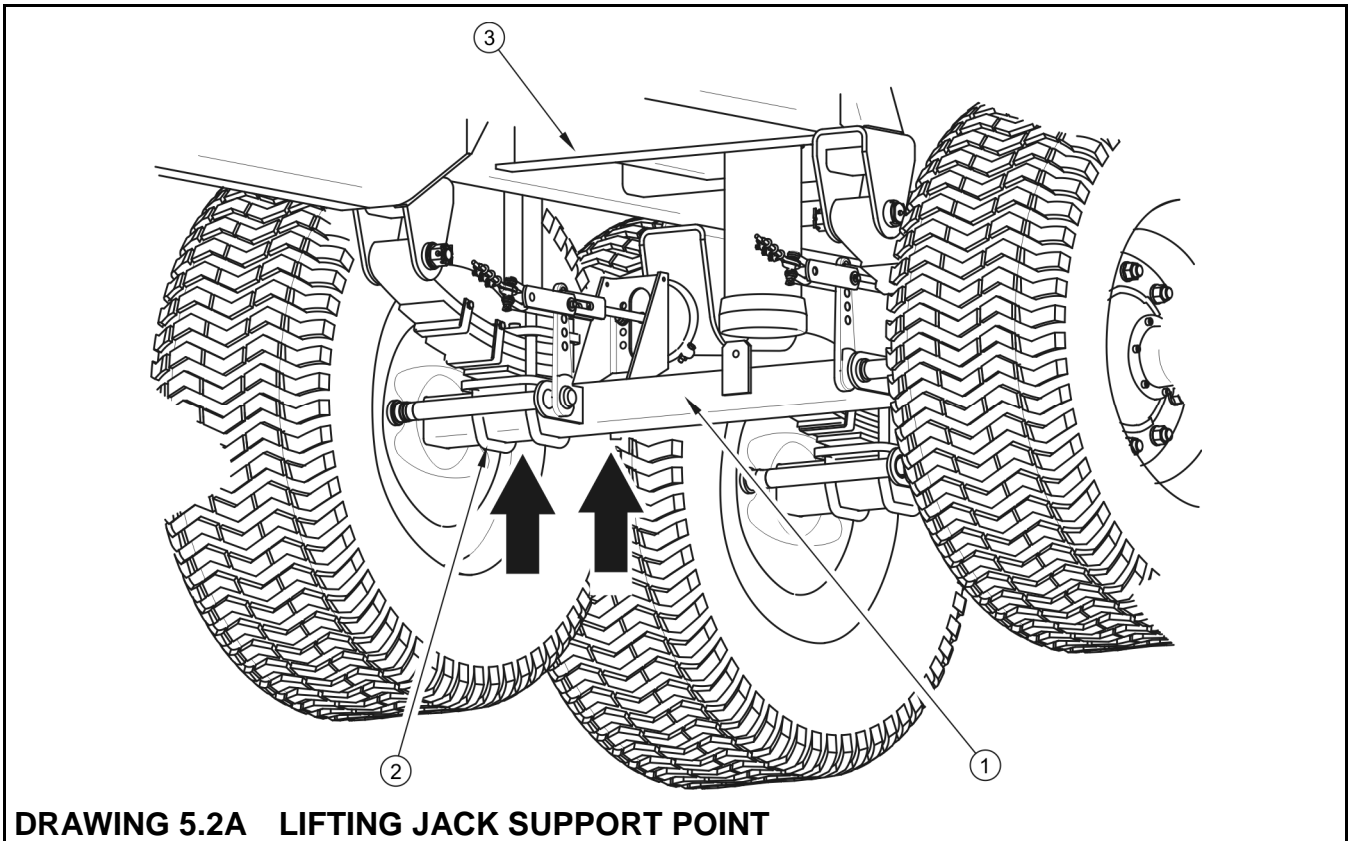

(1) wheel axle, (2) U bolt, (3) lower frame

If slack is felt, it is necessary to adjust bearing. Unusual sounds coming from bearing may be symptoms of excess wear, dirt or damage. In such an event the bearing, together with sealing ring, should be replaced with new parts.

Bearing regulation should be performed according to the following instructions – figure (5.1A):

- take off hub cover (1),
- take out split cotter pin (3) securing castellated nut (2),
- turning the wheel simultaneously tighten castellated nut until the wheel comes to a stop,
- unscrew nut IN (A) direction, (not less than 1/3 rotation) to cover the nearest thread groove with alignment to opening in wheel stub axle (B).
- secure castellated nut with cotter pin and mount hub cap.

The wheel should turn smoothly without faltering or detectable resistance not originating from abrasion of brake shoes in brake drum.

Bearings replacement, lubrication and repairs connected with brake system and wheel axle should be entrusted to specialist service provider.



Inspection of slack and technical condition of wheel axle bearings must be performed after the first month of use, and then every 6 months of trailer use.

5.2 REGULATION OF MAIN BRAKES

Brakes regulation is necessary when:

- as a result of wear of brake shoe linings between lining and drum there is excessive slack and reduced braking effectiveness.
- wheel brakes do not brake evenly or simultaneously.

If brakes are correctly regulated, braking of trailer road wheel takes place simultaneously. Brakes regulation consists of changing setting of axle shaft expander arm (1) in relation to expander shaft (2). To do this rotate regulation screw (3) in appropriate direction to displace the expander lever:

- to the rear - if brake brakes too late,
- forward - brake brakes too early.

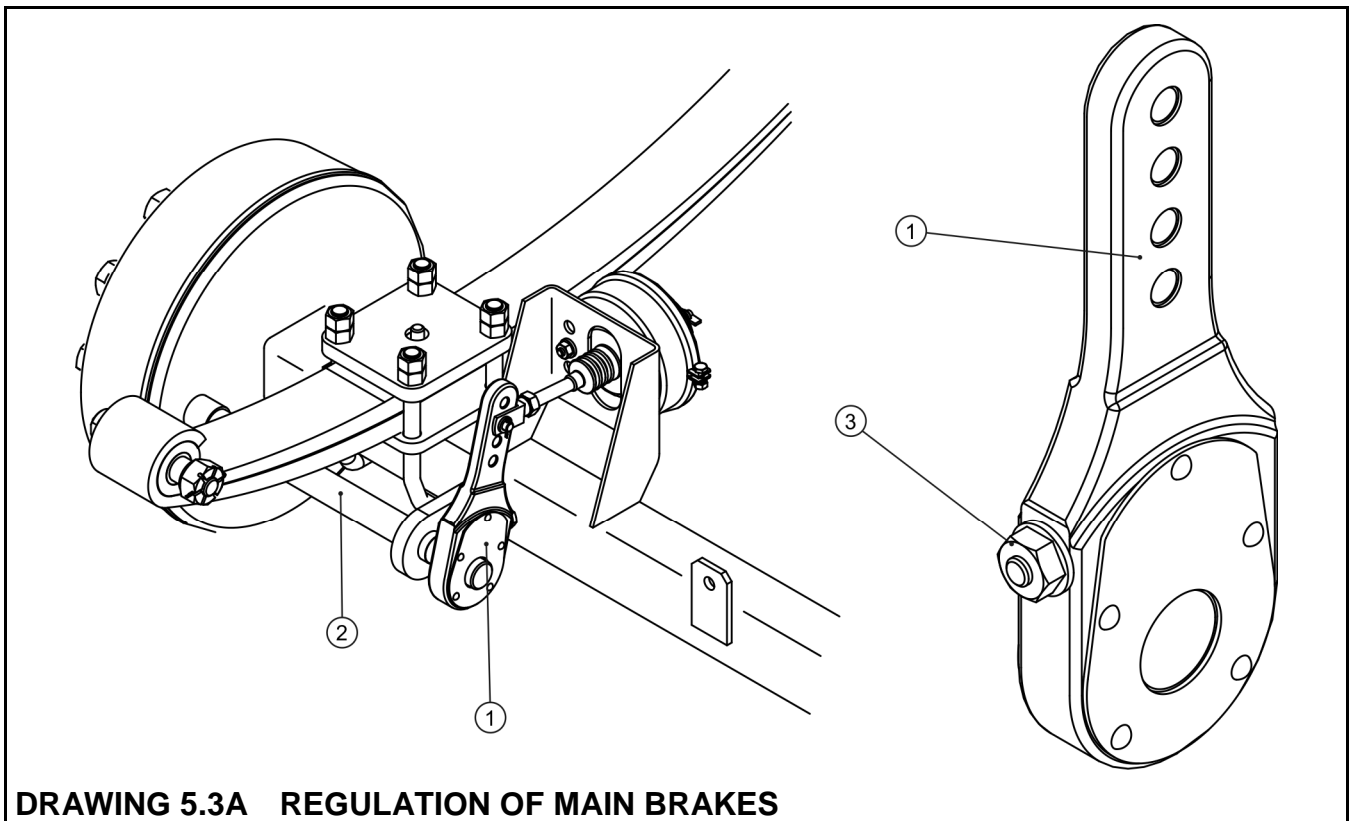

DRAWING 5.3A REGULATION OF MAIN BRAKES

(1) expander arm, (2) expander shaft, (3) regulation screw

TABLE 5.1 MAIN BRAKE BRAKING FORCE

MAIN BRAKE BRAKING FORCE	UNIT
124.5	kN

Regulation should be conducted separately for each wheel. After proper brake regulation, at full braking the axle shaft expander arm should create an angle of 90° with pneumatic ram piston. With properly regulated brakes, trailer main brake braking force should reach a value not less than that given in table(5.1).



ATTENTION!

Braking force of the trailer, is the braking force of all trailer wheels.

Difference in braking force may not be greater than 30%, considering that 100% constitutes greater force.



The main brake system should be inspected annually and in case of need should be regulated.

5.3 REGULATION OF MAIN BRAKES

Regulation of parking brake should be conducted in the event of:

- stretching of cable,
- loosening of parking brake cable clamps
- after regulation of main brake,
- after repairs in main brake system,
- after repairs in parking brake system.

Before commencing regulation make certain that the main brake is functioning properly. Length of parking brake cable should be so selected that at total release of working and parking brake the cable would be loose and hanging by 1 - 2 cm.

With properly regulated brakes, trailer parking brake braking force should reach a value not less than that given in table (5.2). Difference in braking force of left and right wheel may not be greater than 30%, considering that 100% constitutes greater force.

TABLE 5.2 PARKING BRAKE BRAKING FORCE

PARKING BRAKE BRAKING FORCE	UNIT
40.8	kN



ATTENTION!

Braking force of the trailer, is the braking force of all trailer wheels, braked with parking brake.



The parking brake system should be inspected annually and in case of need should be regulated.

5.4 PNEUMATIC SYSTEM OPERATION

As a part of trailer maintenance, it is necessary to conduct inspection of individual pneumatic systems, giving particular attention to places of all connections. Tightness of the system should be checked at nominal pressure in system of approximately 600 kPa (6.0 kg/cm²).

If conduits, seals or other system elements are damaged, compressed air will escape in these damaged places with a characteristic hiss. Lack of system tightness may be exposed by covering checked elements with washing fluid or other foaming preparations, which will not react aggressively with system elements. Damaged seals or conduits, causing leaks should be replaced. If the cause of the system leak is the outflow from a piston, control valve body or braking force regulator should be taken to authorised repair provider for repair or replacement of parts.

Condensation collecting as water should be removed from air tank periodically. In order to do this open out drain valve (2) placed in lower part of tank. The compressed air in the tank causes the removal of water to the exterior. After release valve mandrel should automatically close and stop air flow from tank. Annually before the winter period unscrew drain valve and clean off accumulated dirt. Replace copper seal.



Annually before the winter period unscrew and clean drain valve.

Inspection of tightness and inspection of pneumatic braking systems in detail should be conducted at least annually and after repairs associated with this system.

Depending on trailer working conditions, but not less than once in three months, take out and clean air filter inserts, which are placed in pneumatic system connection conduits. Inserts are used many times and are not subject to changing unless they are mechanically damaged. In order to clean insert first reduce pressure in supply conduit. Next slide out the safety slide lock (1) – figure (5.4A) - filter cover (2) should be covered with other hand. After removing slide lock, the cover is pushed off by the spring, in the filter housing. The insert and the filter

body should be carefully washed out and blown through with compressed air. Assembly should be done in reverse order.

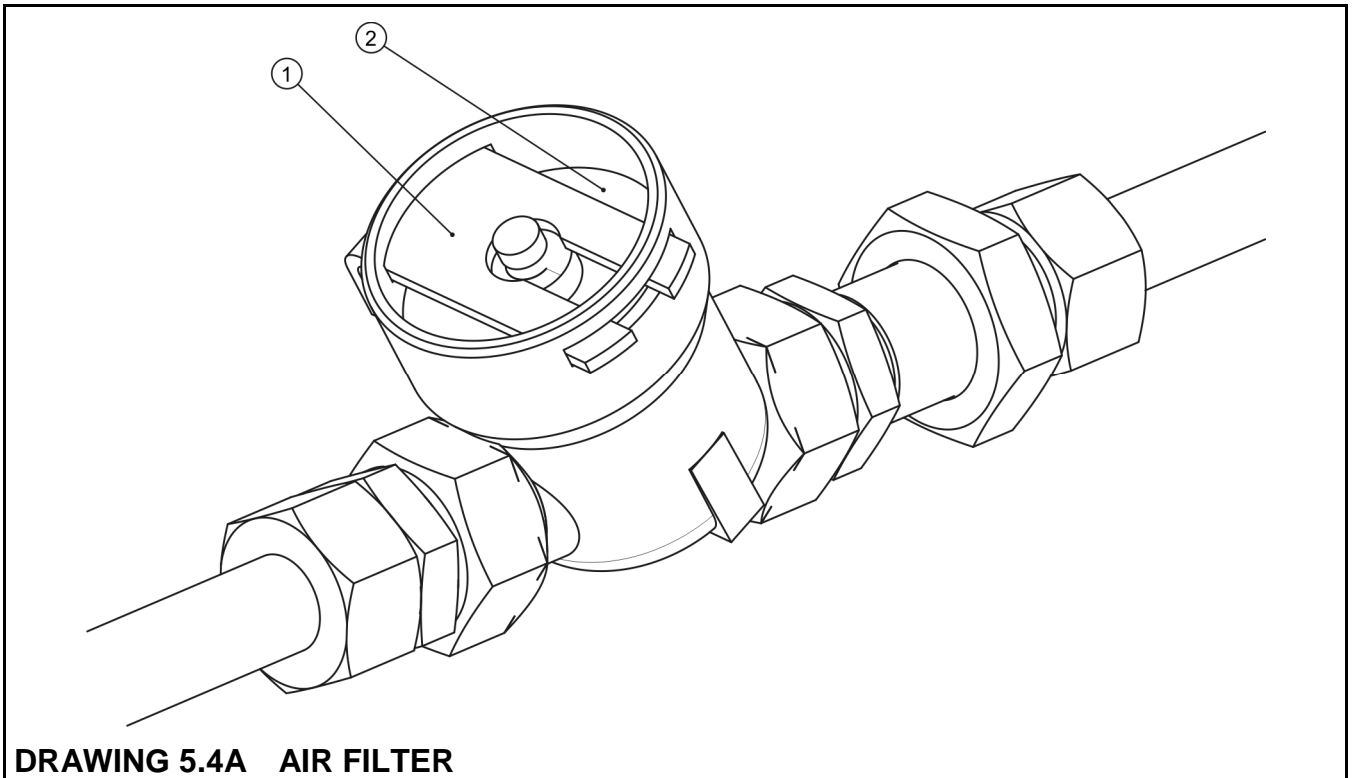

DRAWING 5.4A AIR FILTER

(1) securing slide lock, (2) air filter cover



DANGER

Before proceeding to dismantle filter, reduce pressure in supply conduit.

While disengaging filter slide gate, hold cover with other hand. Stand away from filter cover vertical direction.



The insert and the air filter body should be cleaned at least every 3 months of trailer use.

Pneumatic system connection must be inspected on regularly during use of trailer and if necessary cleaned of all contamination. Particular attention should be paid to the technical condition of security covers and rubber seals. If these elements are damaged they should be replaced.

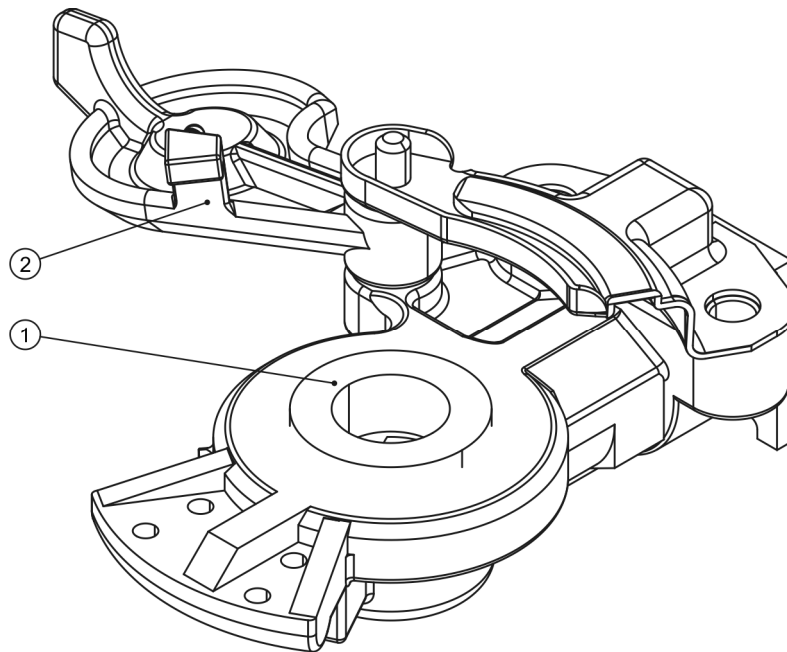

DRAWING 5.5A CONDUIT CONNECTIONS

(1) rubber seal, (2) security cover

It is recommended that seals are preserved with silicon preparation, specified for rubber elements every six months. Contact of the seals with fuel, lubricants being petroleum derivatives, paints etc., causes rapid ageing of the material from which they are made.



Connection should be inspected every time before connecting trailer to tractor. During connection make sure that tractor socket is not damaged and is maintained in the due cleanliness.

5.5 HYDRAULIC SYSTEM OPERATION

Always adhere to the principle that the oil in the trailer hydraulic system and in the tractor hydraulic system are the same type. Application of different types of oil is not permitted. In a new trailer system is filled with HL32 hydraulic oil.

The hydraulic system should be completely tight sealed. Checking tightness of hydraulic system consists of connecting machine with tractor and starting hydraulic cylinder rams and holding them in position of maximum extension for a period of 30 seconds. In the event of confirmation of an oil leak on hydraulic conduit connections, tighten connections, and if this does not remedy faults then it is necessary to change conduit or connection elements. If oil leak occurs beyond connection, the leaking conduit system should be changed. Change of

sub assemblies is equally required in each instance of mechanical damage. In the event of confirmation of damage of hydraulic ram cylinders they must be replaced or repaired. In such an event the whole set of seals must be changed.



Hydraulic conduits should be replaced after 4 years of trailer use.

Detailed tightness and technical condition inspection of hydraulic system should be made at least annually.

TABLE 5.3 HL32 HYDRAULIC OIL CHARACTERISTICS

ITEM	NAME	VALUE
1	ISO 3448VG viscosity classification	32
2	Kinematic viscosity at 40 ⁰ C	28.8 – 35.2 mm ² /s
3	ISO 6743/99 viscosity classification	HL
4	DIN 51502 quality classification	HL

ATTENTION!



Trailer with a leaking hydraulic system must NOT be used.

The condition of hydraulic systems should be inspected regularly while using trailer.

The hydraulic system is under high pressure when operating.

Regularly check the technical condition of the connections and the hydraulic conduits.

Use the hydraulic oil recommended by the Producer. Never mix two types of oil.

In the event of necessity of changing hydraulic oil for another oil, check the recommendations of the oil producer very carefully. If it is recommended to flush the system with the appropriate preparation, then it is necessary to comply with these recommendations. Attention should be given, so that chemical substances used for this purpose do not damage the materials of the hydraulic system.

The oil applied because of its composition is not classified as a dangerous substance, however long-term action on the skin or eyes may cause irritation. In the event of contact of

oil with skin wash the place of contact with water and soap. Do not apply organic solvents (petrol, kerosene). Contaminated clothing should be changed to prevent access of oil to skin. In the event of contact of oil with eye, rinse with large quantity of water and in the event of the occurrence of irritation consult a doctor. Hydraulic oil in normal conditions is not harmful to the respiratory tract. A hazard only occurs when oil is strongly atomised (oil vapour), or in the case of fire during which toxic compounds may be released. Oil fires should be quenched with the use of carbon dioxide, foam or extinguisher steam.

5.6 LUBRICATION

Trailer lubrication must be carried out in places indicated in figures (5.6A) & (5.7A), and also detailed in table (5.4).

TABLE 5.4 GREASING POINTS

ITEM	NAME	NUMBER OF GREASING POINTS	TYPE OF GREASE	GREASING FREQUENCY
1	Articulated joints and sockets for installation of load box.	4	permanent	2 months
2	Sockets for installation of tipping ram cylinder	2	permanent	6 months
3	Absorber spring pins	4	permanent	6 months
4	Rocker arm pins	2	permanent	6 months
5	Absorber spring sliding surfaces	4	permanent	1 month
6	Axle bearings	4	permanent	24 months
7	Axle expander shaft sleeves	4	permanent	6 months
8	Absorber spring	4	anticorrosion and penetration	6 months
9	Wall extension hinges and wall locks	10	permanent	1 month
10	Handbrake mechanism	1	permanent	6 months

ITEM	NAME	NUMBER OF GREASING POINTS	TYPE OF GREASE	GREASING FREQUENCY
11	Slide gate guides	2 or 6★★	Silicone	1 month
12	Slide gate pins in the rear wall	6	Silicone	1 month
13	Wall pins and locks	12	Silicone	1 month
14	Tipping ram cylinder ball bearing	1	permanent	6 months
15	Drawbar pins	2	permanent	3 months
16	Wall locking mechanism	4	permanent	3 months

★ not shown on figure

★★ Depending on wall configuration - 2 or 6 lubrication points

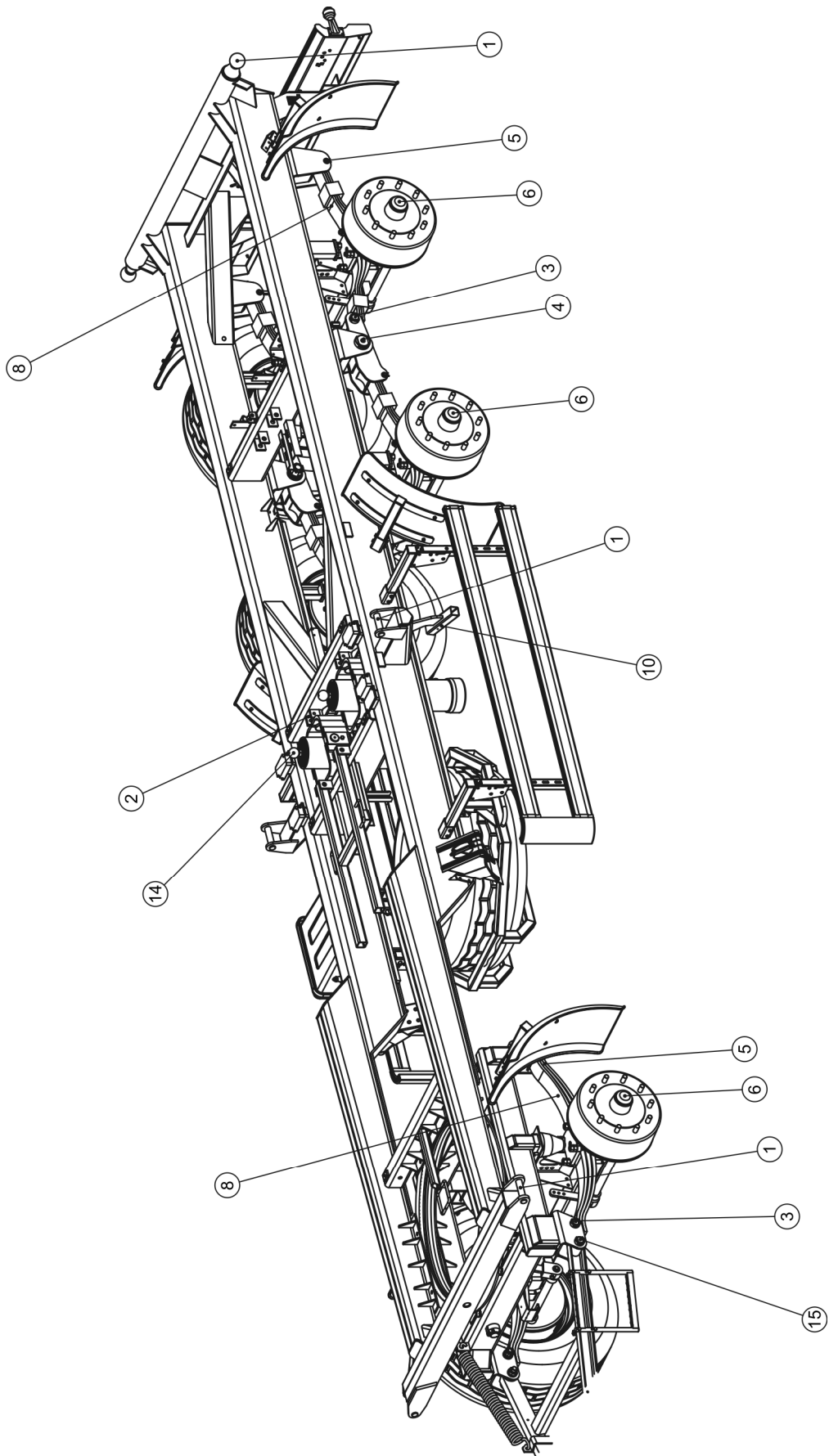

DRAWING 5.6A CHASSIS GREASING POINTS

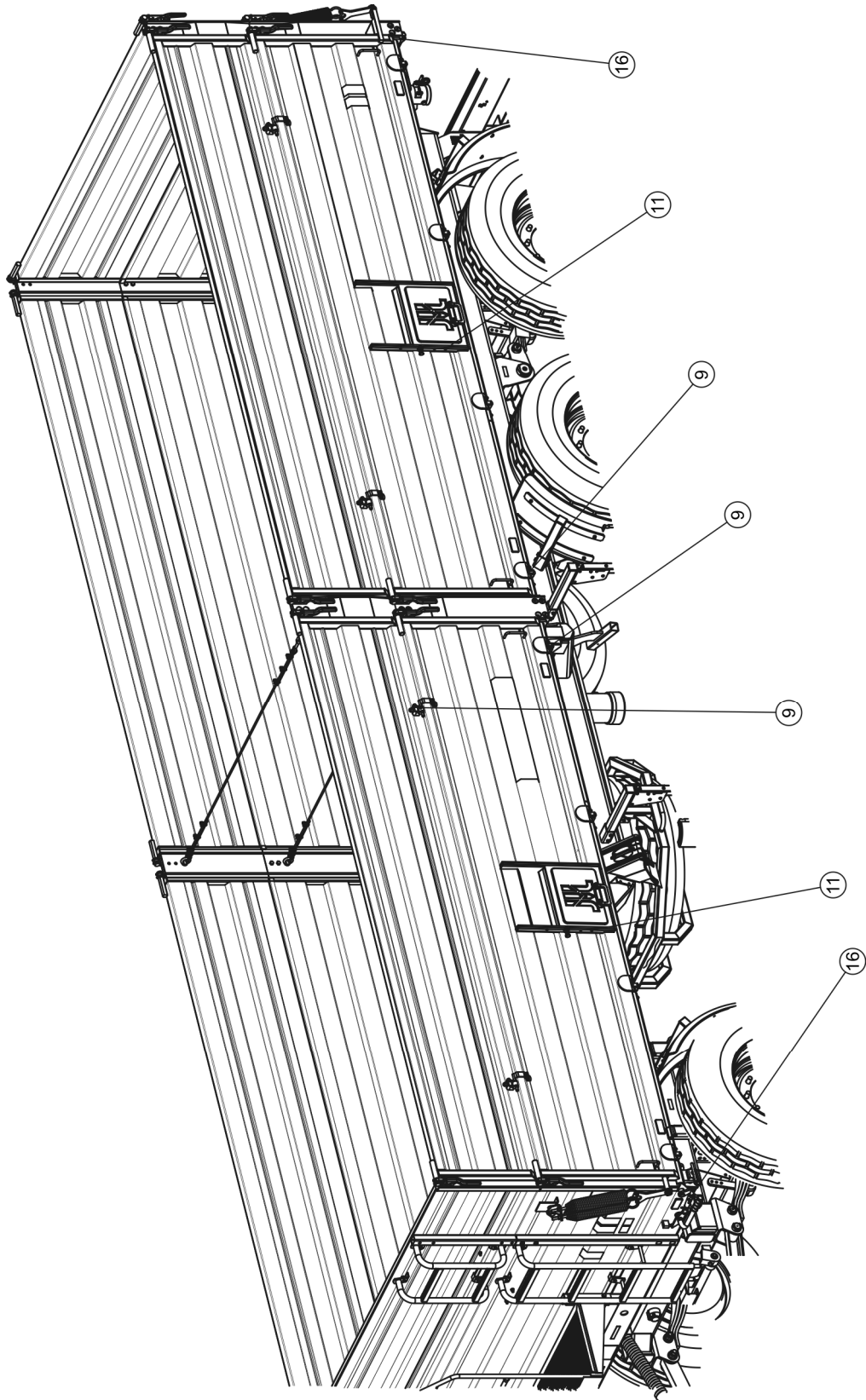

DRAWING 5.7A LOAD BOX GREASING POINTS

Trailer greasing should be performed with the aid of a manually or foot operated grease gun, filled with generally available permanent grease. Absorber plates should be lubricated using an agent having both anticorrosion and lubricating properties, it is recommended to apply on outer surfaces very thin layer of grease. For this purpose, silicone spray (for lubricating of guides, lock etc see table) can be used.

After greasing the trailer according to instructions, wipe off excess grease. Changing grease in wheel hub axle bearings should be entrusted to professional service.



During trailer use the user is obliged to observe greasing instructions according to attached schedule. Excess greasing substance causes depositing additional contaminants in places requiring greasing, therefore it is essential to keep individual machine elements clean.

5.7 INSTALLATION AND DISASSEMBLY OF THE FRAME AND CANVAS COVER

Canvas cover can only be used together with the frame and fenced platform. Fenced platform is located on the trailer's front wall. It provides convenient and safe location for work associated with canvas cover. The canvas cover should be rolled up and unrolled while standing on the fenced platform. Be especially careful when on the fence platform. Stand firmly and hold the railing with one hand. Secure the cover using belts.

The frame's of structure comprises front and rear stakes as well as connecting pipe. Installation of the frame and canvas cover should be conducted as follows:

- Attach stakes to wall extensions,
- Screw the pipe to stakes,
- Put the canvas cover on the right side and rest it on the limiters,
- Unroll the canvas cover and attach belts to appropriate wall extension lugs.

Disassembly of the frame and canvas cover should be performed in reverse order.

ATTENTION!



Assembly and disassembly of the frame should be carried out with the use of appropriate platforms, ladders or when standing on a ramp. These tools must be in good condition to fully protect the persons working on them against falling. Work should be performed by at least two persons. Exercise caution when working.

In the final phase of folding the canvas cover, at all times hold with one hand the railing of the fenced platform or front stake of the frame. Non-compliance with this rule can put the user at risk of falling.

5.8 INSTALLATION AND DISASSEMBLY OF EXTENSION WALLS

Installation of wall extensions should be performed as follows:

- Attach rear stakes of extension walls to rear wall stakes,
- Install middle wall extensions takes,
- Install front and a rear wall extension,
- Install side wall extensions,
- Screw in side step and extension ladder to the front wall.
- Screw in fenced platform.

Disassembly of wall extensions should be performed in reverse order.

ATTENTION!



Assembly and disassembly of wall extensions should be carried out with the use of appropriate platforms, ladders or when standing on a ramp. These tools must be in good condition to fully protect the persons working on them against falling. Work should be performed by at least two persons. Exercise caution when working.

when using the trailer with a third wall extension installed there is an increased risk of: Loss of trailer stability, trailers overturning, failure of the trailer's structural elements, insufficient visibility of the elements of trailer's body, uncontrolled movements of the trailer's body on an uneven terrain, the risk of overloading.

5.9 ABSORBER SPRING SYSTEM MAINTENANCE

Maintenance of the absorber spring system involves periodical lubrication of the suspension in locations indicated in table (5.4) and described in the Lubrication section and periodical monitoring of the technical condition of absorber plates.

The surfaces between the absorber plates should be protected using silicone spray with anticorrosion and lubrication properties. Do not allow a thick layer of dry mud to accumulate on absorber plates.

5.10 STORAGE

After finishing work with trailer cleaned thoroughly and wash with water jet. In the event of damage to the paint coat, clean rust and dust from damaged area, degrease and then paint with undercoat and after it is dry paint with surface coat paint retaining colour uniformity and even thickness of protective coating. Until the time of repainting the damaged place may be covered with a thin layer of grease or anticorrosion preparation. Trailer should be kept in closed or roofed building.

5.11 TRAILER PREPARATION FOR END OF SEASON

If the trailer will not be used for a long time, it is essential to protect it from adverse weather, especially rust and accelerated tyre deterioration. During this time trailer must be unloaded.

Trailer and canvas cover should be very carefully washed and dried. While washing do not direct a strong water or steam jet at information and warning stickers, hydraulic or pneumatic cylinders, electrical equipment, and hydraulic and pneumatic systems. If possible, clean and dry canvas cover should be stored unfolded and suspended, otherwise it should be carefully rolled up without any creases.

Corroded areas should be protected as described above in previous subsection.

Tyres should undergo conservation maintenance at least twice a year using the appropriate preparations designed for this purpose. Wheels and tyres should be previously carefully washed and dried. During longer storage of unused trailer it is recommended that every 2 to 3 weeks the trailer may be moved a bit so that the place of contact of tyres with ground is changed. So that tyres are not deformed and maintain proper geometry. Also tyre pressure should be inspected from time to time, and if necessary pressure should be increased to appropriate value.

Lubricate elements according to guidelines presented in section "Lubrication".

5.12 TIGHTENING TORQUE FOR NUT AND BOLT CONNECTIONS

Unless other tightening parameters are given, during maintenance repair work apply appropriate torque to tightening nut and bolt connections. Recommended tightening torque of most frequently applied nut and bolt connections are given in table (5.5). Given values apply to non greased steel bolts.

TABLE 5.5 TIGHTENING TORQUE FOR NUT AND BOLT CONNECTIONS

THREAD (d) [mm]	5.8	8.8	10.9
	M _D [Nm]		
M6	8	10	15
M8	18	25	36
M10	37	49	72
M12	64	85	125
M14	100	135	200
M16	160	210	310
M20	300	425	610
M24	530	730	1050
M27	820	1150	1650
M30	1050	1450	2100

(M_D) – tightening torque, (d) thread diameter

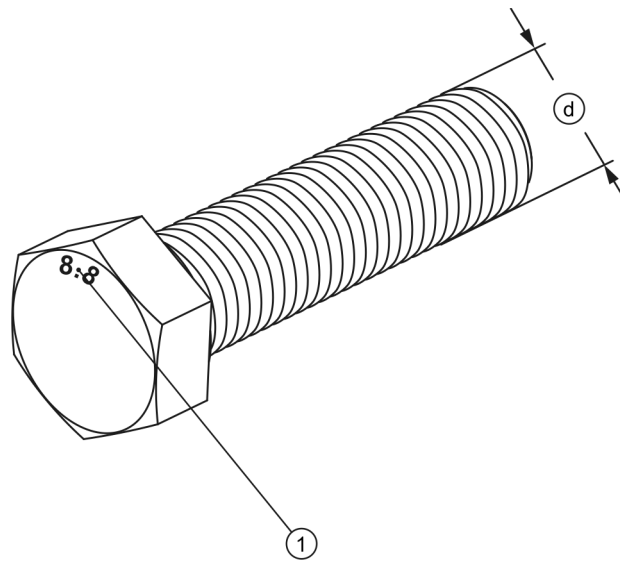

DRAWING 5.8A BOLT WITH METRIC THREAD

(1) bolt strength class, (d) thread diameter

5.13 FAULTS AND MEANS OF REMEDYING THEM

TABLE 5.6 FAULTS AND MEANS OF REMEDYING THEM

FAULT	CAUSE	REMEDY
Problem with moving off	Brake system pneumatic conduits not connected	Connect brake conduit.
	Damaged pneumatic system connection conduit	Replace
	Leaking connections	Tighten, replace washers or seal set
	Parking brake applied	Release parking brake
Noise in axle hubs	Excessive slack in bearings	Checks slack and regulate if needed
	Damaged bearing	Change bearing together with sealing ring
Excessive heating of axle hubs	Incorrectly regulated main brake	Regulate setting of expander arms
	Incorrectly regulated parking brake	Regulate tension of parking brake cables

FAULT	CAUSE	REMEDY
	Worn brake linings	Change brake shoes
Tipping the load box and not possible	Hydraulic tipping system conduit not connected	Connect the conduit
	Hydraulic circuits control valve set to position 2	Set the valve the position 1
	Cut-off valve stuck or the cable for controlling the cut-off valve is blocked	Check the routing of the control cable and if the cut-off valve is fully functional. Replace if cut-off valve is damaged.

5.14 LIST OF BULBS

TABLE 5.7 LIST OF BULBS

LAMP	BULB
Front position light left/right LO - 110PP	C5W-SV8.5
Left/right clearance light	R5W
License plate light LT - 120	C5W-SV8.5
Rear lamp group: left WE 549L, right WE 549P	indicator light: P21W brake light: P21W parking light: R10W



ATTENTION!

The trailer's electrical system is supplied with 12V.

NOTES

A series of horizontal dotted lines for writing notes.



ANNEX A

Tire sizes

TRAILER VERSION	TIRE
T780	385/65 R 22.5 160 K ⁽¹⁾ 425/65 R 22.5 160 F ⁽²⁾ 445/65 R 22.5 170 F ⁽³⁾ 500/60 R 22.5 165 A8 ⁽⁴⁾ 560/60 R 22.5 161 D ⁽⁴⁾

⁽¹⁾ - disc wheel 11.75x22.5" ET=-30

⁽²⁾ - disc wheel 13.00x22.5" ET=0

⁽³⁾ - disc wheel 14.00x22.5" ET=0

⁽⁴⁾ - disc wheel 16.00x22.5" ET=0