



PRONAR SP. Z O.O.

17-210 NAREW, UL. MICKIEWICZA 101A, WOJ. PODLASKIE

TEL.: +48 085 681 63 29

+48 085 681 64 29

+48 085 681 63 81

+48 085 681 63 82

FAX: +48 085 681 63 83

+48 085 682 71 10

www.pronar.pl

USER MANUAL

AGRICULTURAL TRAILER PRONAR T672ECO

ORIGINAL MANUAL

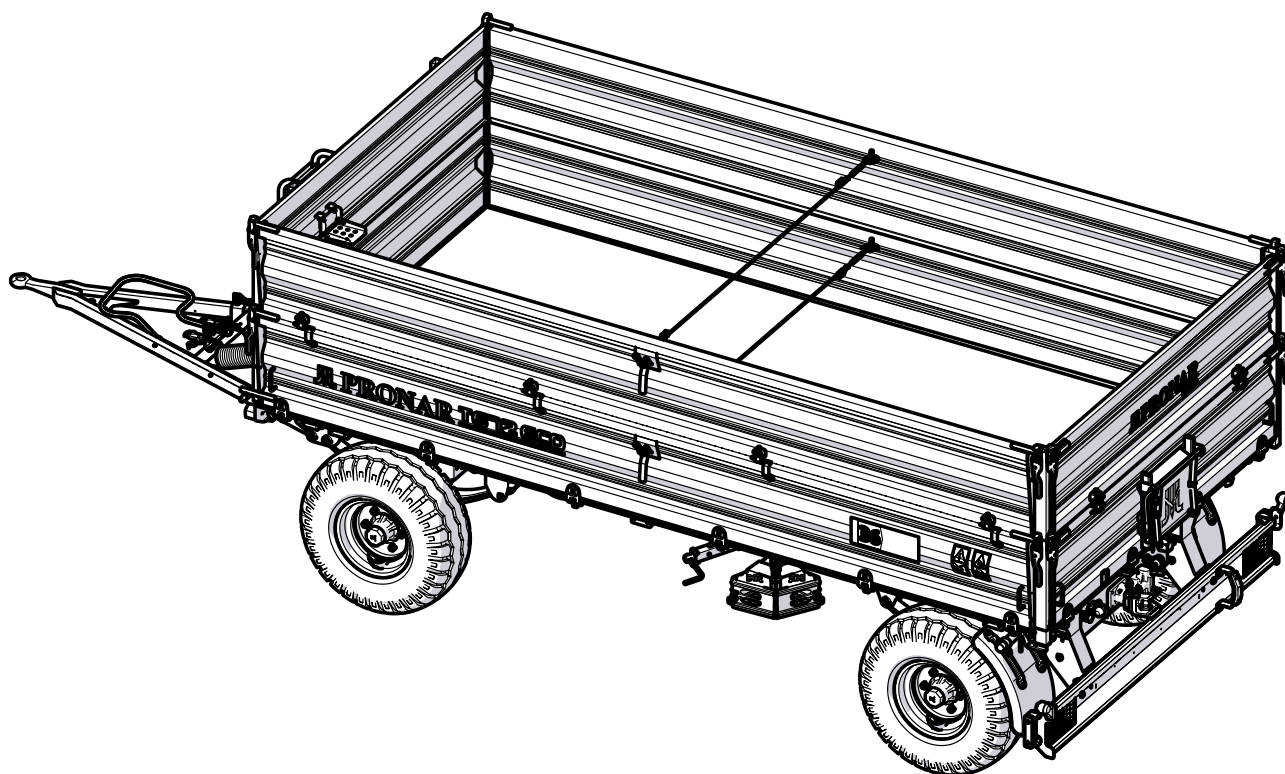

SAFE FOR FUTURE USE

ISSUE: 1A

05-2020

EDITION NO. 619.00.UM.1A.EN



Copyright © PRONAR Sp. z o.o. All rights reserved

This study is the property of PRONAR Sp. z o.o. and is a work within the meaning of the Copyright and Related Rights Act. No part of this document may be distributed or copied in any way (electronic, mechanical or other) without the written consent of PRONAR Sp. z o.o.

INTRODUCTION

INTRODUCTION

The information contained in the publication is current as at the date of publication. As a result of improvement, some sizes and illustrations contained in this publication may not correspond to the actual state of the machine delivered to the user. The manufacturer reserves the right to introduce constructional changes in the manufactured machines to facilitate operation and improve the quality of their work, without making any current changes to this publication.

The operating instruction is the basic equipment of the machine. Before using the machine, the user must read the

contents of this manual and observe all recommendations contained therein. This will guarantee safe and trouble-free operation of the machine. The machine was constructed in accordance with applicable standards, documents and current legal regulations.

If the information contained in the operating instructions does not turn out to be comprehensible, please contact the sales office where the machine was purchased or directly to the Manufacturer.

After purchasing the machine, we recommend to enter the machine serial number in the fields below.

Machine serial number

--	--	--	--	--	--	--	--	--	--	--	--	--	--	--	--	--	--	--	--

This manual contains important safety and operating instructions for the machine. The manual should be kept near the machine so that it is available for authorized persons.

Keep this manual for future reference. If the manual is lost or damaged, contact the seller or the manufacturer for a duplicate.

The manual instruction is intended for the end user. For this reason, some required maintenance is listed in the inspection tables but the procedure is not described in this publication. To perform them, call the manufacturer's authorized service centre.

U.10.1.EN

SYMBOLS USED IN THE MANUAL

DANGER

Information, descriptions of hazards and precautions as well as instructions and orders related to the safety of use in the content of the manual are marked with a frame with the word **DANGER**. Failure to comply with these recommendations may endanger the health or life of persons operating the machine or bystanders.

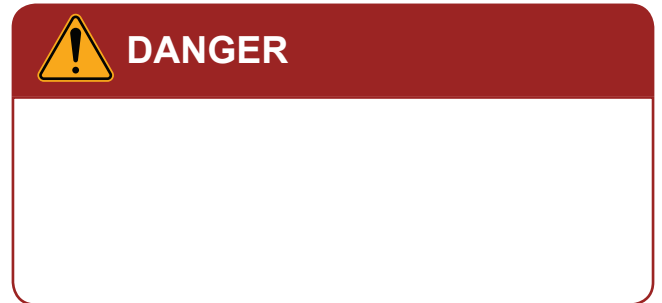

CAUTION

Particularly important information and recommendations, the observance of which is absolutely necessary, are highlighted in the text with a frame and word **CAUTION**. Failure to comply with these recommendations creates the risk of damage to the machine due to improper handling, adjustment or use.



ADVICE

Additional instructions contained in the manual describe useful information on operating the machine and are marked with a frame with the word **ADVICE**.



U.02.1.EN

DESIGNATION OF DIRECTIONS IN THE MANUAL

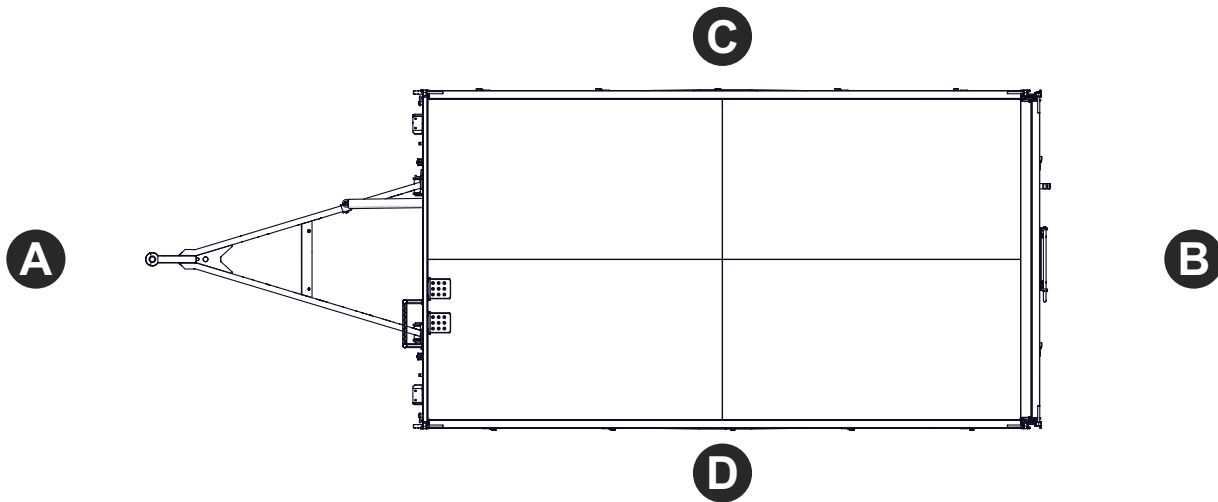

Figure 1.1 Determining directions on the machine
 (A) - front (B) rear (C) right side (D) left side

Left side – the left hand side of the observer facing the machine in the forward direction.

Right side – the right hand side of the observer facing the machine in the forward direction.

Turn right – turn the mechanism clockwise (operator facing the mechanism).

Turn left – turn the mechanism counter-clockwise (operator facing the mechanism).

U.03.1.EN

CHECKING THE MACHINE AFTER DELIVERY

The manufacturer ensures that the machine is fully functional, has been checked in accordance with control procedures and is approved for use. However, this does not release the user from the obligation to check the machine after delivery and before first use. The machine is delivered to the user completely assembled. Detailed information on the transfer can be found in the WARRANTY BOOK.

CONTROL RECOMMENDATIONS

- Check the completeness of the machine in accordance with the order (standard and optional equipment).
- Check the machine for missing parts or damage resulting from incorrect transport of the machine to its destination point (dents, punctures, bends or broken parts, etc.).
- Check technical condition of guards, safety devices.
- Check the condition of the paint coating, check for any signs of corrosion.
- Check the condition of the tires on the road wheels and the air pressure

ADVICE

The delivery of the machine includes a detailed inspection and check of the operation of the machine, as well as instructing the buyer on the basic principles of use. The first start-up takes place in the presence of the Seller.

in the tires.

- Check the correct tightening of the wheels.
- Check the technical condition of the drawbar eye and its attachment.
- Check the technical condition of the flexible hydraulic hoses.
- Check technical condition of pneumatic conduits.
- Make sure there are no hydraulic oil leaks.
- Check the machine's lighting electric lamps.
- Check the electrical controls (panel, harness).
- Check cylinders for hydraulic oil leaks.

In case of any irregularities found, report them directly to the seller to remove any defects.

U.11.2.EN

START-UP OF THE MACHINE



CAUTION

The first start-up involves checking the machine in the presence of the Seller. The Seller is obliged to carry out training in the safe and proper operation of the machine.

Training by the seller does not release the user from the obligation to become familiar with the contents of this manual and to follow the recommendations contained therein.

Before starting the machine, the user will be familiarized with its construction, principle of operation, available equipment and operation, and above all safety rules.

THE SCOPE OF ACTIVITIES

- Read the contents of this *OPERATOR'S MANUAL* and follow the recommendations contained therein.
 - Adjust the height of the eye drawbar to the hitch on your tractor.
 - Perform a daily review machine according to the guidelines in the schedule Inspection.
 - Check all machine lubrication points, if necessary lubricate as recommended in lubricating.
 - Check the correct tightening of screw connections (in particular the suspension, drawbar and road wheels).
 - Make sure that the pneumatic, hydraulic and electrical connections on the agricultural tractor comply with the requirements, otherwise do not connect the trailer.
 - Make sure that the hydraulic oil in the trailer and tractor is of the same type and grade.
- If all of the above activities have been carried out and the technical condition of the trailer does not raise any objections, connect the machine to the tractor.
- Start the tractor, check individual systems and carry out a test run of the machine and perform a test drive without load (without a loading box). It is recommended that visual inspection be carried out by two people, one of them should be permanently in the tractor's cab. The test run must be carried out in the order shown below.
- Connect the machine to the appropriate hitch on the agricultural tractor.
 - Connect the brake, electrical and hydraulic system lines.
 - By activating individual lights, check the correct operation of the electrical system.
 - Activate and check correct operation of the hydraulic tipping system.
 - When moving off check the operation of the service brake.
 - Perform a test drive. While driving,

check the braking effect of the machine.

- Stop the tractor and turn off the engine, immobilize the tractor and the machine with the parking brake.

If during the test trip, disturbing symptoms such as:

- excessive noise and unnatural noises from rubbing moving parts,
- leakage and pressure drop in the braking system,
- improper operation of hydraulic and/or pneumatic cylinders,
- other faults,

do not use the trailer until the removal of



DANGER

Careless and improper use and operation of the machine, as well as non-compliance with the recommendations contained in the operating instructions, pose a threat to health and life.

The machine must not be used by unauthorized persons, children, people under the influence of alcohol or other drugs.

Non-compliance with the rules of safe use poses a threat to the health of the operating and bystanders.

fault. If the fault cannot be rectified or remedied, you will void the warranty, contact the place of purchase for clarification or repair.

After completing the test drive, check the tightness of the wheel nuts.

U.12.3.EN



PRONAR Sp. z o.o.

ul. Mickiewicza 101 A
17-210 Narew, Polska

tel./fax (+48 85) 681 63 29, 681 63 81, 681 63 82,
681 63 84, 681 64 29

fax (+48 85) 681 63 83

http://www.pronar.pl

e-mail: pronar@pronar.pl

EC DECLARATION OF CONFORMITY OF THE MACHINERY

PRONAR Sp. z o.o. declares with full responsibility, that the machine:

Description and identification of the machinery	
Generic denomination and function:	AGRICULTURAL TRAILER
Type:	T672
Model:	-----
Serial number:	
Commercial name:	TRAILER PRONAR T672ECO

to which this declaration relates, fulfills all the relevant provisions of the Directive **2006/42/EC** of The European Parliament and of The Council of 17 May 2006 on machinery, and amending Directive 95/16/EC (Official Journal of the EU, L 157/24 of 09.06.2006).

The person authorized to compile the technical file is the Head of Research and Development Department at PRONAR Sp. z o.o., 17-210 Narew, ul. Mickiewicza 101A, Poland.

This declaration relates exclusively to the machinery in the state in which it was placed on the market, and excludes components which are added and/or operations carried out subsequently by the final user.

PRONAR Spółka z o.o.
17-210 Narew ul. Mickiewicza 101A
Tel. (85) 681 63 29 , 682 72 54
Fax: (85) 681 63 83
NIP 543-02-00-939, KRS 0000139188
BDO 000014169

Z-CIA DYREKTORA
d/s technicznych
czynności zarządku
Roman Wnietianuk
Roman Wnietianuk

Narew, the 15.05.2020

Place and date

Full name of the empowered person
position, signature

TABLE OF CONTENTS

INTRODUCTION	2
SYMBOLS USED IN THE MANUAL	3
DESIGNATION OF DIRECTIONS IN THE MANUAL	4
CHECKING THE MACHINE AFTER DELIVERY	5
START-UP OF THE MACHINE	6

GENERAL

1.1	IDENTIFICATION	1.2
1.2	DRIVING AXLE IDENTIFICATION	1.3
1.3	INTENDED USE	1.4
1.4	REQUIREMENTS	1.6
1.5	EQUIPEMENT	1.8
1.6	TERMS OF WARRANTY	1.10
1.7	TRANSPORT	1.11
1.8	THREAT TO THE ENVIRONMENT	1.14
1.9	WITHDRAWAL FROM USE	1.15

SAFETY OF USE

2.1	BASIC SAFETY RULES	2.2
2.2	SAFETY WHEN THE MACHINE AGGREGATING	2.4
2.3	SAFETY RULES FOR OPERATING HYDRAULIC AND PNEUMATIC SYSTEMS	2.5
2.4	RULES OF SAFE TECHNICAL SERVICE	2.6
2.5	RULES OF SAFE DRIVING ON ROADS	2.9
2.6	LOADING AND UNLOADING OF THE TRAILER	2.12
2.7	TIRES	2.14
2.8	DESCRIPTION OF RESIDUAL RISK	2.15
2.9	INFORMATION AND WARNING STICKERS	2.16

CONSTRUCTION AND PRINCIPLE OF OPERATION

3.1	TECHNICAL CHARACTERISTICS	3.2
3.2	GENERAL CONSTRUCTION	3.3
3.3	LOAD BOX	3.6
3.4	SERVICE BRAKE	3.9
3.5	HYDRAULIC TIPPING SYSTEM	3.13
3.6	PARKING BRAKE	3.15
3.7	ELECTRICAL LIGHTING INSTALLATION	3.16

RULES OF USE

4.1	ADJUSTING THE POSITION OF THE DRAWBAR	4.2
4.2	CONNECTING AND DISCONNECTING OF THE TRAILER	4.3
4.3	CONNECTING AND DISCONNECTING OF A SECOND TRAILER	4.7
4.4	LOADING	4.9
4.5	LOAD TRANSPORTATION	4.16

4.6	UNLOADING _____	4.18
4.7	CHUTE GATE SERVICE _____	4.20
4.8	OPERATION OF THE WALL EXTRACTOR MECHANISM _____	4.23
4.9	TARPAULIN SERVICE _____	4.24
4.10	RULES FOR USE OF TIRES _____	4.26
4.11	CLEANING OF THE TRAILER _____	4.28
4.12	STORAGE _____	4.30

PERIODIC INSPECTIONS OF THE TRAILER

5.1	GENERAL _____	5.2
5.2	PERIODIC INSPECTION SCHEDULE _____	5.3
5.3	PREPARATION OF THE TRAILER _____	5.6
5.4	CHECKING THE AIR PRESSURE IN THE WHEELS _____	5.7
5.5	TANK DRAINAGE _____	5.8
5.6	CHECKING PLUGS AND CONNECTION SOCKETS _____	5.9
5.7	CHECKING THE TRAILER BEFORE DRIVING OFF _____	5.10
5.8	MEASUREMENT OF AIR PRESSURE, CHECK TIRES AND WHEELS _____	5.11
5.9	CLEANING THE AIR FILTERS _____	5.12
5.10	CHECKING BRAKE LINING WEAR _____	5.13
5.11	CHECKING THE CLEARANCE OF THE AXLE BEARINGS _____	5.14
5.12	CHECKING OF MECHANICAL BRAKES _____	5.15
5.13	CLEANING THE DRAINAGE VALVE _____	5.16
5.14	CHECKING OF PARKING BRAKE CABLE TENSION _____	5.17
5.15	BRAKE CABLE TENSION ADJUSTMENT _____	5.19
5.16	HYDRAULIC SYSTEM INSPECTION _____	5.20
5.17	CONTROL OF PNEUMATIC SYSTEM _____	5.21
5.18	SCREW CONNECTIONS INSPECTION _____	5.22
5.19	LUBRICATION _____	5.24
5.20	REPLACEMENT OF HYDRAULIC HOSES _____	5.30

TECHNICAL SUPPORT

6.1	WHEEL ASSEMBLY AND DISASSEMBLY _____	6.2
6.2	PARKING BRAKE CABLE REPLACEMENT _____	6.3
6.3	ADJUSTING THE CLEARANCE OF THE AXLE BEARINGS _____	6.4
6.4	ADJUSTMENT OF BRAKES _____	6.5
6.5	ELECTRICAL SYSTEM SERVICE AND WARNING ELEMENTS _____	6.10
6.6	CONSUMABLES _____	6.12
6.7	TROUBLESHOOTING _____	6.14

APPENDIX A

CHAPTER 1

GENERAL

1.1 IDENTIFICATION

S Z B 6 7 2 E X X

Item	Meaning
A	General information and function
B	Trailer symbol / type
C	Year of machine production
D	VIN Number
E	Certificate approval number
F	The machine's karb weight
G	Permissible gross weight
H	Permissible load on coupling
I	Permissible axle load
J	Technical permissible gross weight
K	Technical permissible axle load

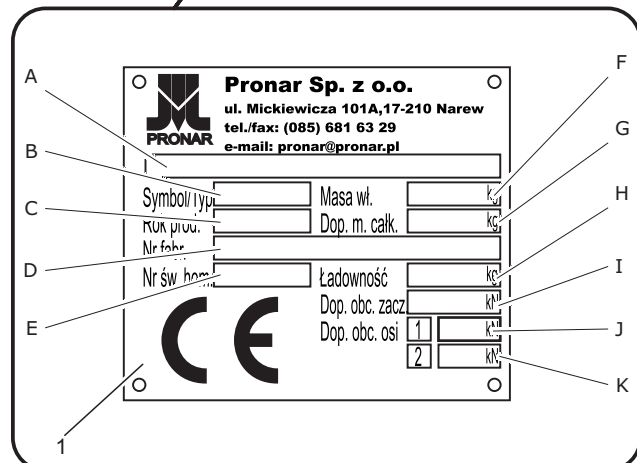
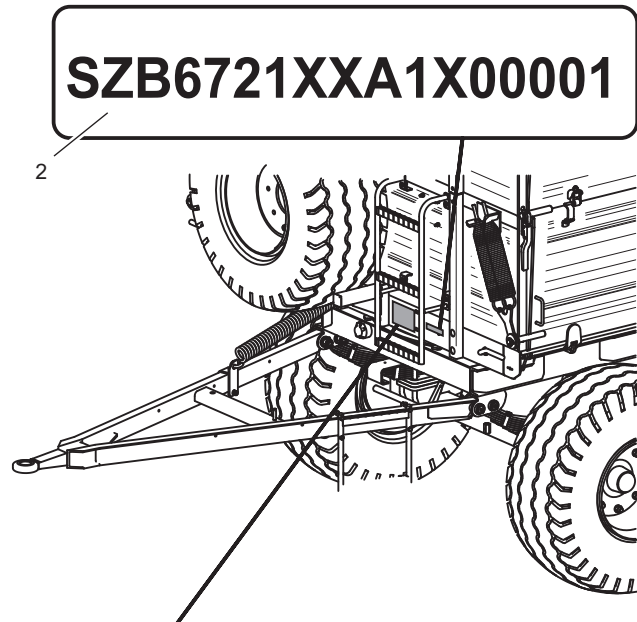

619-E.01-1

Table 1.1. Nameplate markings

The trailer was marked with a nameplate (1) and the serial number (2) placed on a rectangular field painted in gold. The serial number and the nameplate are located on the front beam of upper frame - figure (1.1).

When purchasing the trial, check that the serial numbers on the machine match the number entered in the WARRANTY CARD, in the sales documents and in the USER MANUAL. The meaning of the individual

Figure 1.1 Identification of trailer

(1) nameplate

(2) trailer VIN number

fields on the nameplate is shown in the table below.

Record the trailer's serial number in the top field.

E.3.3.619.01.1.EN

1.2 DRIVING AXLE IDENTIFICATION

The serial number of the driving axles and their type is stamped on the type plate (2) attached to the driving axle profile - figure (1.2). After purchasing the trailer, it is recommended to enter the individual serial numbers in the fields below.

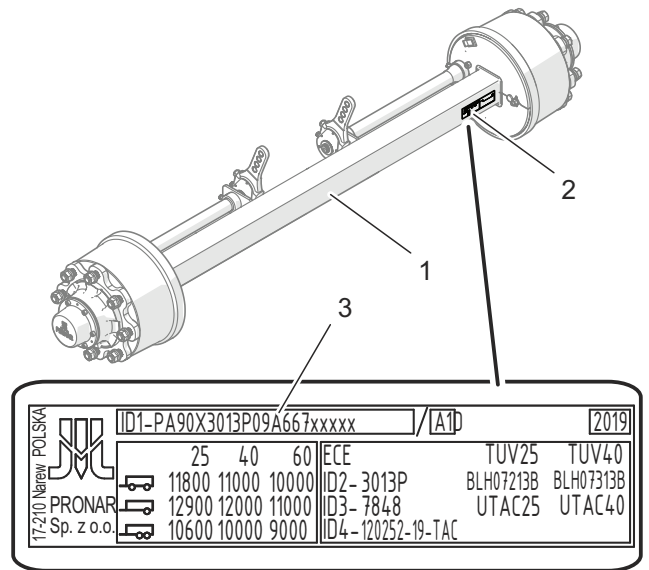

622-E.02-1

Figure 1.2 Axis identification

- (1) driving axle
- (2) nameplate
- (3) axle serial number

E.3.4.622.02.1.EN

1.3 INTENDED USE



DANGER

The machine may not be used for purposes other than those for which it is intended.

The trailer is designed for transporting agricultural crops and products (loose, volumetric, long-haul, etc.), within the farm and on public roads. Transportation of building materials, mineral fertilizers and other loads is allowed provided that the requirements of Chapter 4 are met. Non-compliance with the recommendations of carriage and loading specified by the Manufacturer and road transport regulations in force in the country in which the trailer is used will void the warranty services and is treated as using the machine for purposes other than those intended.

The trailer is not adapted and intended for the transport of people, animals and goods classified as hazardous materials.

The trailer was constructed in accordance with applicable safety requirements and machine standards.

Braking system and lighting system as well as signalling meet the requirements of traffic regulations.

In the countries where the trailer is used, restrictions related to the road traffic laws in force in a given country must be observed.

The trailer speed must not, however, be greater than the maximum design speed 40 km/h.

Intended use also includes all activities related to the correct and safe operation and maintenance of the machine. Therefore, the user is obliged to:

- Read the content of trailer's USER MANUAL and WARRANTY CARD and to the guidelines contained in these documents,
- understand the principle of machine operation and the safe and proper operation of the trailer,
- work in compliance with established maintenance and adjustment plans,
- work in compliance with general safety regulations,
- accident prevention,
- comply with road traffic regulations and transport regulations in force in the country in which the trailer is used,
- get acquainted with the contents of the farm tractor instruction manual and comply with its recommendations,
- couple the vehicle only with such an agricultural tractor that meets all the requirements set by the trailer Manufacturer.

The trailer may only be used by persons who:

- Become familiar with the contents of publications and documents attached to the trailer and the contents of manual agricultural tractor,
- have been trained in trailer operation and work safety,
- have the required authorization to drive and are familiar with the traffic rules and transport regulations.

The trailer may not be used for purposes other than those for which it is intended, in particular:

- Transport of people, animals, dangerous materials, aggressive loads as a result of chemical reactions to trailer structural elements (causing

corrosion of steel, damaging paint coverings, dissolving plastic elements, destroying rubber elements, etc.),

- transport improperly secured cargo that could cause road and environmental pollution while driving,
- transport of incorrectly secured cargo, which could change its position in the load box during driving,
- transport of cargo that location of the center of gravity adversely affects the stability of the trailer,
- carry loads that affect uneven loading and/or overloading of the axles and suspension components.

E.3.3.619.03.1.EN

1.4 REQUIREMENTS

Table 1.2. Agricultural tractor requirements

Content	Unit	Requirements
Braking system - sockets		
Pneumatic 2 - wire	-	in accordance with ISO 1728
Hydraulic	-	in accordance with ISO - 7421-1
Maximum system pressure		
Pneumatic 2 - wire	bar / kPa	8 / 800
Hydraulic	bar / MPa	150 / 15
Hydraulic tipping system		
Hydraulic oil	-	L HL 32 Lotos (1)
Maximum system pressure	bar / MPa	160 / 16
Oil demand	l	13
Electrical system		
Electrical system voltage	V	12
Connection socket	-	7 poles in accordance with ISO 1724
Tractor hitch required		
Type of hitch	-	Upper transport hitch
Other requirements		
Min. tractor power	kW/KM	47.8 / 65

(1) – a different oil may be used, provided it can be mixed with oil in the trailer. Detailed information can be found in the product information card.

If a second trailer is connected to the trailer, it must meet the requirements specified in table (1.3).

Table 1.3. Second trailer requirements

Content	Unit	Requirements
Permissible gross weight	kg	8,000
Braking system - sockets		
Pneumatic 2 - wire	-	in accordance with ISO 1728
Hydraulic	-	in accordance with ISO - 7421-1
Maximum system pressure		
Pneumatic 2 - wire	bar / kPa	8 / 800
Hydraulic	bar / MPa	150 / 15
Hydraulic tipping system		
Hydraulic oil	-	L HL 32 Lotos (1)
Maximum system pressure	bar / MPa	160 / 16
Oil demand	l	13
Electrical system		
Electrical system voltage	V	12
Connection socket	-	7 poles in accordance with ISO 1724
Trailer drawbar		
The drawbar eye diameter	mm	40

(1) – a different oil may be used, provided it can be mixed with oil in the trailer. Detailed information can be found in the product information card.

E.3.3.619.04.1.EN

1.5 EQUIPEMENT

Table 1.4. Trailer equipment

Equipment	STANDARD	ADDITIONAL	OPTIONAL
User manual	•		
Warranty Card	•		
Hand brake	•		
Wheel chocks	•		
Drawbar V ø40		•	
Fenders		•	
Spare wheel hanger		•	
Feeder assembly		•	
Document tube		•	
Wall hanger		•	
Shock absorbing belts L = 1800		•	
Rear chute system		•	
Chute		•	
Balcony		•	
Bort extraction mechanism		•	
Rear manual hitch		•	
Rear automatic hitch		•	
Warning triangle		•	
Plate for slow-moving vehicles		•	
Tarpaulin frame		•	
Hydraulic tipping system			•
Mesh extensions (8mm)			•
Mesh extensions (30mm)			•
Fi-40 Y drawbar			•
Set of attachable tops 500 (P) front wall with a window			•

Braking system 2pp WT			•
Braking system 2pp ALB			•
Braking system 2pp ALB WT			•
Overrun brake system (axles, drawbar, braking system)			•

(1) Some standard equipment items that are listed in the table may not be included in the trailer supplied. This is due to the possibility of ordering a new machine with a different set - optional equipment, replacing the standard equipment.

Tire information is provided at the end of the publication in APPENDIX A.

E.3.4.622.05.1.EN

1.6 TERMS OF WARRANTY

ADVICE

You should require the seller to carefully fill out the *Warranty Card* and complaint coupons. The lack of e.g. date of sale or point of sale stamp exposes the user to not accept any complaints.

PRONAR Sp. z o.o. in Narew guarantees easy operation of the machine when it is used in accordance with the technical and operational conditions described in the *USER MANUAL*. Deadline for completion of repairs is specified in the *Warranty Card*.

The warranty does not apply to parts and sub-assemblies of the machine, which are subject to wear in normal operating conditions, regardless of the warranty period. The warranty services only apply to such cases as: mechanical damage not caused by the fault of the user, factory defects of parts, etc.

In the event that damage occurs as a result of:

- mechanical damage caused by the

user's fault, road accident,

- from improper operation, adjustment and maintenance, use contrary to its purpose,
- use of a damaged machine,
- repairs carried out by unauthorized persons, improper repairs,
- execution of user changes in machine design,

the user loses the warranty.

The user is obliged to immediately report all noticed defects in the paint coatings or traces of corrosion, and order removal of defects regardless of whether the damage is covered by the warranty or not.

Detailed warranty conditions are given in the *WARRANTY CARD* attached to the newly purchased machine.

Modifications to the machine without the written consent of the Manufacturer are prohibited. In particular, welding, reaming, cutting and heating of the main machine components that directly affect safety during use are not permitted.

E.3.4.622.06.1.EN

1.7 TRANSPORT

The machine is ready for sale completely assembled and does not require packing. Only the machine's technical documentation and any additional equipment elements are packed. Delivery to the user is carried out by road or independent transport (towing a trailer with an agricultural tractor).

TRUCKING

Loading and unloading of a trailer from

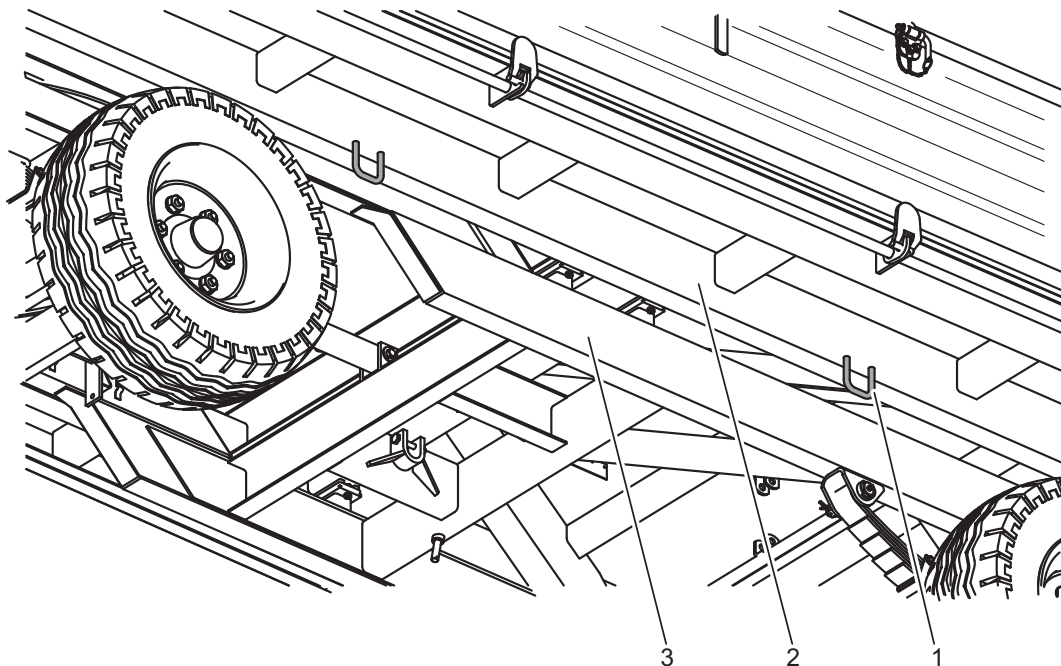

619-E.03-1

Figure 1.3 Trailer attachment points

(1) carrying handle (2) upper frame member, (3) bottom frame member



DANGER

Incorrect use of securing measures can cause an accident

a car should be carried out using a loading ramp and a farm tractor. During work act in compliance with the general principles



DANGER

During road transport, the trailer must be mounted on the platform of the vehicle in accordance with safety requirements and regulations.

While driving, the car driver should exercise extreme caution. This is due to the vehicle's centre of gravity shifting upwards with the machine loaded.

Use only approved and technically reliable securing measures. Read the operating instructions of the securing measures manufacturer.

of workplace health and safety for reloading work. Persons operating reloading equipment must have the required permissions to use these devices. The machine must be correctly connected to the tractor in accordance with the requirements

contained in this manual. The trailer braking system must be activated and checked before going down or onto the ramp.

The machine should be attached firmly to the platform of the vehicle using straps, chains, lashings or other fastening devices equipped with a tensioning mechanism. The fastening elements should be attached to the transport eyelets designed for this purpose (1) - figure (1.3). Transport eyelets are welded to the upper frame side members (2).

Chocks or other elements without sharp edges should be placed under the trailer wheels, protecting the machine against rolling. The wheel must be secured to the vehicle loading platform in such a way that it cannot move.

Use certified and technically reliable securing measures. Wiping belts, cracked fasteners, bent or corroded hooks or other damage may disqualify the product from being used. Please refer to the instructions in the operating instructions of the manufacturer of the securing material used. The number of fastening elements (ropes, belts, chains, lashings, etc.) and the force needed for their tension depends, among others, on the weight of the trailer, the construction of the car carrying the trailer, the speed of travel and other conditions.



CAUTION

It is forbidden to attach slings and all kinds of fastening elements to the elements of the hydraulic and electrical systems as well as the slender elements of the machine (e.g. covers, wires)

Therefore, it is not possible to specify the fastening plan in detail.

In order to optimally attach the trailer to the loading platform, support the drawbar by placing a support in the form of a wooden block under it. A properly attached trailer will not change its position relative to the transporting vehicle. The fastening means must be selected according to the manufacturer's instructions. In case of doubt, a larger number of attachment and securing points for the trailer should be used. If necessary, protect the sharp edges of the trailer, thus securing the securing means against damage during transport.

During reloading work, particular attention should be paid so as not to damage the machine equipment components and the paint coating. The kerb weight of the trailer in running order is given in table (3.1).

USER'S TRANSPORT

In case of independent transport organised



DANGER

When transporting independently, the operator should read the instructions the operating and follow the recommendations contained therein.

by the user after purchasing the trailer, read the trailer User Manual and follow its recommendations. Independent transport involves towing a trailer with own

agricultural tractor to its destination. While driving, adjust the speed to the prevailing road conditions, but it must not be greater than the maximum design speed.

E.3.4.619.07.1.EN

1.8 THREAT TO THE ENVIRONMENT

A hydraulic oil leak is a direct threat to the natural environment owing to its limited biodegradability. Repair works with a risk of leakage of oil, should be carried out in rooms with an oil resistant surface. In the event of oil leaking into the environment, first of all contain the source of the leak, and then collect the leaked oil using available means. Collect oil residue with sorbents or mix the oil with sand, sawdust or other absorbent materials. Collected oil contaminants should be stored in an airtight and marked container, resistant to hydrocarbons, and then transferred to an oil waste disposal point. The container should be kept away from heat sources, flammable materials and food.

Oil which has been used up or is unsuitable for further use due to the loss of its properties is recommended to be stored in its original packaging in the same conditions



CAUTION

Oil waste can only be delivered to a point dealing with the utilization or regeneration of oils. It is prohibited to throw or pour oil into the sewage system or water reservoirs.



DANGER

Do not store oil waste in food containers. Store used oil in containers resistant to hydrocarbons.

ADVICE

The trailer's hydraulic system is filled with L-HL 32 Lotos oil.

as described previously. Waste code 13 01 10 (hydraulic oil). Detailed information on oil can be found in the product safety data sheet.

E.3.4.622.08.1.EN

1.9 WITHDRAWAL FROM USE

If the user decides to withdraw the machine from use, comply with the provisions in force in the given country regarding withdrawal from use and recycling of machines withdrawn from use.

Before dismantling the machine, the oil must be completely removed from the hydraulic system.

In the event of parts being replaced, worn or damaged parts should be sent to a recycling centre. Used oil as well as rubber or



DANGER

During dismantling, use appropriate tools and equipment (overhead cranes, elevators, lifts, etc.) and use personal protective equipment, i.e. protective clothing, footwear, gloves, glasses, etc.
Avoid oil contact with skin. Do not allow oil to leak.

plastic elements should be taken to plants dealing with the utilization of this type of waste.

E.3.4.622.09.1.EN

CHAPTER 2

SAFETY OF USE

2.1 BASIC SAFETY RULES

- Use of the trailer for any other purpose is prohibited. Everyone who uses the trailer in a manner contrary to its intended use, thus takes full responsibility for all consequences arising from its use. Using the trailer in a manner not in accordance with the manufacturer's instructions may void the warranty.
 - Before using the trailer, the user should carefully read the content of this document and the WARRANTY CARD. During their operation, all recommendations contained therein must be observed.
 - The trailer may only be used and operated by persons authorized to drive agricultural tractors with a trailer.
 - The trailer user is obliged to become familiar with the construction, operation and principles of safe machine operation.
 - If the information contained in the User's Manual is difficult to understand, contact a seller who runs an authorized technical service on behalf of the manufacturer, or contact the manufacturer directly.
 - Access to the trailer is possible only with the machine absolutely still.
- Stop the agricultural tractor, remove the ignition key of the tractor, secure the trailer and tractor against rolling by placing wedges. Immobilize the trailer and tractor with parking brake. Use the appropriate height and strength of the platform or ladder to climb. It is forbidden to climb onto the trailer using underrun protection and wheels.
- Careless and improper use and operation of the trailer, non-observance of the recommendations contained in these instructions creates a threat to health.
 - The trailer may only be used when all the covers and other protective elements are functional and properly fastened.
 - Be aware of the existence of a minimal risk of danger, therefore the application of the principles of safe use and sound behavior should be the basic principle of using a trailer.
 - The machine must not be used by persons who are not authorized to drive agricultural tractors, including children, people under the influence of alcohol or other drugs.
 - Non-compliance with the rules of safe

use poses a threat to the health of the operating and bystanders.

- Assembly and disassembly of extensions as well as the frame and tarpaulin should be carried out using the appropriate height of platforms, ladders or ramps. The condition of these devices must protect working people against falling. This work
- should be performed by at least two people.
- In the final phase of rolling up the tarpaulin, it is essential to hold one hand on the top of the front frame or other solid structural elements of the trailer. Failure to do so may result in a fall.

F.3.2.259.01.1.EN

2.2 SAFETY WHEN THE MACHINE AGGREGATING

- Take special care when connecting the machine.
- When connecting, nobody may be between the trailer and the tractor.
- Do not aggregate the trailer if the agricultural tractor does not meet the minimum requirements set by the manufacturer.
- Before connecting the trailer, make sure that the oil in the tractor's external hydraulic system can be mixed with the trailer's hydraulic oil.
- Before coupling the trailer, make sure that both machines are technically sound.
- When coupling of the trailer use the appropriate tractor hitch. After coupling the machines, check the the hitch safety device. The trailer's linkage height should be optimally adapted to the height of the hitch. If necessary, read the tractor's manual.
- If the tractor is equipped with an automatic hitch, make sure that the coupling operation is completed.
- Hitching and unhitching of the trailer may only take place when the machine is immobilized by means of the parking brake. If the trailer stands on a slope, it must be additionally secured against rolling by placing wedges or other elements without sharp edges under the wheels.

F.3.3.259.02.1.EN

2.3 SAFETY RULES FOR OPERATING HYDRAULIC AND PNEUMATIC SYSTEMS

- The hydraulic and pneumatic systems are under high pressure during operation.
- Regularly check the technical condition of connections and hydraulic and pneumatic hoses. The trailer may not be operated with leaking installations.
- In the event of a failure of the hydraulic or pneumatic system, the trailer should be decommissioned until the failure is removed.
- Repairs and replacements of pneumatic and hydraulic system elements should be entrusted to appropriately qualified persons.
- When connecting the hydraulic conduits to the tractor, make sure that the tractor hydraulic system and trailer are not under pressure. If necessary, reduce the residual pressure of the system.
- In the event of injuries being caused by pressurized hydraulic oil, contact a doctor immediately. Hydraulic oil can penetrate the skin and cause infection. If the oil gets into the eyes, rinse with plenty of water and if irritation occurs, contact a doctor. In the event of contact of oil with skin, wash the area of contact with water and soap. Do not use organic solvents (petrol, kerosene).
- Use hydraulic oil recommended by the manufacturer.
- After changing the hydraulic oil, the used oil must be disposed. Used oil or oil which has lost its properties should be stored in original containers or replacement packaging resistant to hydrocarbons. Replacement containers must be accurately described and properly stored.
- It is forbidden to store hydraulic oil in packaging intended for food storage.
- Rubber hydraulic conduits must be replaced every 4 years regardless of their technical condition.

F.3.3.259.05.1.EN

2.4 RULES OF SAFE TECHNICAL SERVICE

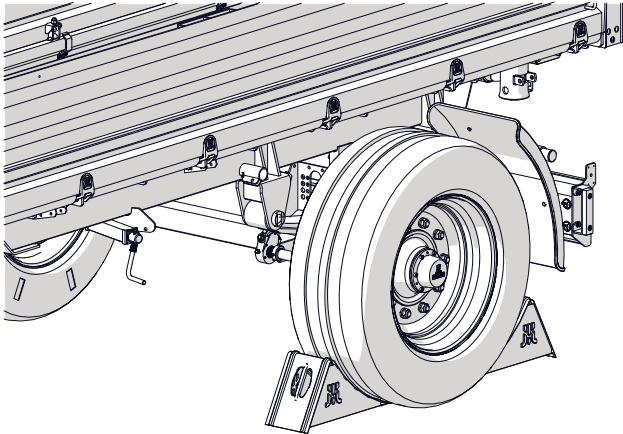

259-F.01-1

Figure 2.1 Laying of locking wedges

- During the warranty period, any repairs may only be carried out by a Warranty Service authorized by the manufacturer. After the end of the warranty period, it is recommended that any repairs to the trailer be carried out by specialized workshops.
- In the event of any faults or damage, the trailer should be decommissioned until repaired.
- During maintenance work, use appropriate, close-fitting protective clothing, gloves, shoes, glasses and the right tools.
- Any modification of the trailer releases PRONAR Narew from any liability for damage or injury.
- Climbing the trailer is possible only when the trailer is absolutely stationary and the tractor engine is switched off. Tractor and trailer should be secured with parking brake and wedges should be placed under trailer wheels. Secure the tractor cab against unauthorized access.
- Regularly check the technical condition of safety devices and correct tightening of screw connections (in particular the drawbar eye and wheels).
- Inspect the trailer according to the frequency specified in this manual.
- Before starting repair work on hydraulic or pneumatic systems, the residual oil or air pressure must be completely reduced.
- Perform maintenance and repair activities applying general principles of health and safety at work. In the event of a cut, the wound should be immediately washed and disinfected. In case of serious injuries consult a physician.
- Repair, maintenance and cleaning work should only be carried out with the tractor engine switched off and the ignition key removed. Tractor and trailer should be secured with parking brake and wedges should be placed under trailer wheels. Secure

the tractor cab against unauthorized access.

- During maintenance or repair work, the trailer may be disconnected from the tractor, but secured by means of wedges and parking brake.
- If it is necessary to replace individual parts, use only parts recommended by the manufacturer. Failure to comply with these requirements may endanger the health or life of bystanders or persons operating the trailer, cause damage to the machine and constitute the basis for withdrawing the warranty.
- Before welding or electrical work, the trailer should be disconnected from the power supply. The paint coating should be cleaned. The fumes of burning paint are poisonous to humans and animals. Welding work should be carried out in a well-lit and ventilated room.
- During welding work pay attention to flammable or fusible elements (elements of pneumatic, electric, hydraulic systems, elements made of plastic). If there is a risk of ignition or damage, they must be removed or covered with non-flammable material before welding. Before starting work, it is recommended to prepare a CO₂ or foam extinguisher.
- In the event of work requiring the trailer to be raised, use properly certified hydraulic or mechanical lifts for this purpose. After lifting the machine, stable and durable supports must also be used. It is forbidden to work under a trailer raised only with a lift.
- It is forbidden to support the trailer with fragile elements (bricks, hollow bricks, concrete blocks).
- After completing work associated with lubrication, remove excess grease or oil. The trailer should be kept clean.
- It is forbidden to carry out independent repairs of elements of the hydraulic or pneumatic system, i.e. control valves, actuators and regulators. In case of damage to these elements, the repair should be entrusted to authorized repair centres or replace the elements with new ones.
- It is forbidden to install additional devices or accessories that do not comply with the specification specified by the Manufacturer.
- The trailer may only be towed when the running gear, lighting and braking systems are efficient.
- Before carrying out technical service or maintenance on the trailer, lower the load box. If it is necessary to raise

the load box, turn it over to the side and secure it against falling down using the load box support. The load box cannot be loaded. The trailer

must be connected to the tractor and secured with wedges and blocked with the parking brake.

F.3.3.259.04.1.EN

2.5 RULES OF SAFE DRIVING ON ROADS

- When driving on public roads, comply with traffic regulations and transport regulations in force in the country where the trailer is used.
- Do not exceed the maximum speed resulting from restrictions on road conditions and project restrictions. Adjust speed to prevailing road conditions, container loading level, and restrictions resulting from road traffic regulations.
- Wedges should only be placed under one wheel (one in front of the wheel, the other in the rear).
- It is forbidden to leave the machine unsecured. The trailer disconnected from the tractor must be blocked with the parking brake and secured against rolling with wedges or other elements without sharp edges placed under the vehicle wheels.
- Before driving, make sure that the trailer is correctly connected to the tractor, especially that the hitch pins are secured.
- Vertical load carried by the trailer drawbar eye affects the steering of the agricultural tractor.
- Before using the trailer always check its technical condition, especially in terms of safety. In particular, check the technical condition of the hitch system, the running gear, the braking system and traffic lights as well as the connecting elements of the hydraulic, pneumatic and electrical systems.
- Before driving, check that the parking brake is released and the braking force regulator is in the correct position (applies to pneumatic systems with a manual three-position regulator).
- Before driving, check if the bolts connecting the load box to the lower frame and wall bolts are secured against falling out. Check rear wall slide protection. Make sure that all walls and extensions are properly closed.
- If the trailer is equipped with fastening cables, check if they are fastened properly and secure the cable disconnecting mechanism.
- It is forbidden to drive with the load box raised.
- The trailer is adapted for driving on slopes up to a maximum of 8°. Moving the trailer over slopes may cause the trailer to overturn as a result of loss of stability.
- When driving on public roads, the

tractor operator must ensure that the trailer and tractor are equipped with an approved or homologated warning reflective triangle.

- A triangular plate for slow moving vehicles should be placed on the rear wall, if the trailer is the last vehicle in the set - Figure (2.2). The triangular plate should be placed in a specially prepared holder riveted to the rear

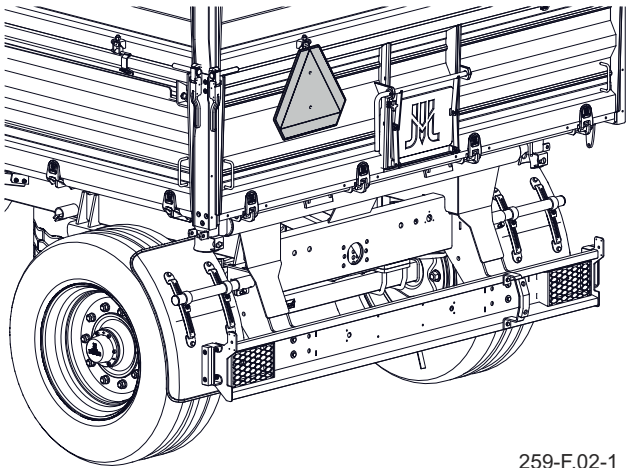

259-F.02-1

Figure 2.2 Location of the board wall of the load box.

- Periodically drain air tanks in the pneumatic system. During frosts, freezing water may cause damage to pneumatic system components.
- Reckless driving and excessive speed can cause an accident.
- Load protruding beyond the outline of the trailer should be marked in accordance with traffic regulations. It is forbidden to transport loads not allowed by the manufacturer.

- The load on the trailer must be evenly distributed and must not hinder driving. The load must be secured so that it cannot slide or tip over.
- The trailer's maximum carrying capacity must not be exceeded. Exceeding the carrying capacity may lead to damage to the machine, loss of stability and cause a hazard while driving. The braking system of the machine has been adapted to the total weight of the trailer, exceeding of which will drastically reduce the operation of the service brake.
- Prolonged driving on sloping ground creates a risk of loss of braking efficiency.
- When reversing, it is recommended to use the help of another person. During manoeuvres, the helping person must keep a safe distance from danger zones and be visible to the tractor operator at all times.
- It is forbidden to get on the trailer while driving.
- Parking the trailer on a decline is prohibited.
- When using the trailer with the fitted centre extensions, there is an increased risk of the following hazards: loss of trailer stability, trailer overturning, loss of strength of trailer

elements, insufficient visibility of the trailer body track, uncontrolled movements of the body on uneven terrain,

risk of overloading. Trailers with central extensions fitted may not be used in public traffic.

F.3.3.259.05.1.EN

2.6 LOADING AND UNLOADING OF THE TRAILER

- Loading and unloading work should be carried out by a person experienced in this type of work.
- If the trailer is equipped with fastening cables for walls and extensions, before loading make sure that they are in place and the cable release mechanism is set in the correct position and secured with a pin. If loading material that does not exert pressure on the side walls, disassembly of the fastening cables is allowed. Otherwise, the pressing load will damage the walls.
- Use only original tipping pins with handle. The use of non-original pins may damage the trailer.
- The trailer is not intended for transporting people, animals and hazardous materials.
- The load must be arranged in such a way that it does not threaten the stability of the trailer and does not hinder driving.
- The arrangement of the load must not cause an overload on the trailer's chassis.
- Incorrectly selected load distribution and overloading the machine may cause the trailer to overturn or damage its components.
- Do not stay on the load box during loading.
- Unloading and loading the trailer can only be carried out when the machine is placed on level, hard and level surface and connected to the tractor. Tractor and trailer must be placed for straight-ahead driving.
- Make sure that there are no bystanders in the unloading / loading area or the raised load box. Before tipping the load box make sure that it is visible and make sure there are no bystanders nearby.
- Before raising the load box, the tipping pins should be placed on the intended unloading side. Check the correct installation of the pins.
- When opening the wall transoms, do not stand in the area of the wall to be opened and the load being unloaded.
- Keep a safe distance from overhead power lines when lifting the box.
- When opening wall closures and locks, be extremely cautious due to pressing the load on the walls.
- Tipping the load box is prohibited during strong wind gusts.
- Unloading of volumetric materials

that have been loaded above 1 meter can only be done by tilting the load box backwards.

- A trailer with additional extensions can only be unloaded by tipping the load box backwards.
- If the load does not pour from the raised load box, unloading must be stopped immediately. Another tipping over is only possible after removing the cause of the non-sliding load.
- In winter, pay special attention to loads that may freeze during transport. At the time of tipping the load box, the frozen load may lead to the loss of stability of the trailer and cause its overturning.
- Do not raise the load box if there is any danger of the load box tipping over.
- It is forbidden to lift the load box with the sides closed.
- It is forbidden to jerk the trailer forward if the bulk or difficult-to-pour load has not been unloaded.
- After unloading make sure the load box is empty.
- When closing or opening the slide window chute, walls and extensions, be very careful to avoid crushing your fingers.
- Do not get in or put your hands between open walls and the load box.

F.3.3.259.06.1.EN

2.7 TIRES

- When working with tires, the trailer should be immobilized with the parking brake and secured against rolling by placing wedges under the wheels. It is recommended to disassemble the wheel when the trailer is without a container.
- Repair work on wheels or tires should be carried out by persons trained and authorized to do so. These works should be carried out using appropriately selected tools.
- Checking the tightening of the wheel nuts should be carried out after the first use of the trailer, every 2-3 hours during the first month of using the machine and then every 30 hours of driving. Each time, repeat all operations if the wheel was disassembled. Wheel nuts bearings should be tightened in accordance with the recommendations contained in the chapters: *MAINTENANCE / Wheel assembly and disassembly*, *PERIODIC INSPECTIONS / Checking screw connections*.
- Avoid damaged road surfaces, sudden and variable maneuvers, and high speeds when turning.
- Check tire pressure regularly. Tire pressure should also be checked during all-day intensive work. It should be taken into account that an increase in tire temperature can increase the pressure by up to 1 bar. With such a rise in temperature and pressure, reduce the load or speed. Never reduce pressure by venting if it increases due to temperature.
- Tire valves should be protected with suitable caps to avoid penetration of dirt.

F.3.3.259.07.1.EN

2.8 DESCRIPTION OF RESIDUAL RISK

Pronar Sp. z o. o. in Narew made every effort to eliminate the risk of an accident. However, there is some residual risk that can lead to an accident and is primarily associated with the following activities:

- using the trailer contrary to its purpose,
- being between the tractor and the trailer when the engine is running and when connecting the machine or connecting a second trailer,
- being on the machine during work,
- failure to maintain a safe distance when loading, disconnecting, connecting or unloading the trailer,
- trailer operation by unauthorized persons or persons under the influence of alcohol or other intoxicants,
- introducing design changes without the consent of the Manufacturer,
- trailer cleaning, maintenance and technical inspection,
- presence of persons or animals in

areas invisible from the operator's position.

Residual risk can be reduced to a minimum by following these recommendations:

- prudent and leisurely machine operation,
- sensible application of the remarks and recommendations contained in the operating instructions,
- keeping a safe distance from prohibited and dangerous places,
- performing maintenance and repair work in accordance with the principles of operating safety,
- carrying out maintenance and repair work by trained persons,
- the use of close-fitting protective clothing and appropriate tools,
- securing the machine against access by unauthorized persons, especially children.
- a ban on being on the machine while driving, loading or unloading.

F.3.3259.081.EN

2.9 INFORMATION AND WARNING STICKERS

The trailer is marked with information and warning decals mentioned in table (2.1). The arrangement of symbols is shown in figure (2.2). The machine user is obliged to ensure that the inscriptions, warning and information symbols placed on the trailer are legible throughout the entire period of use.





In the event of their destruction, they must be replaced. Information and warning stickers can be purchased directly from the Manufacturer or in the place where the machine was purchased.









The catalog numbers of the labels can be found in the table (2.1) and in the *Spare parts catalog*. New assemblies replaced during repair must be marked again with the appropriate safety signs. When cleaning the trailer, do not use solvents that may damage the label coating and do not direct a strong water jet.

Other information stickers on the system connection cables are presented in chapter 4.

F.3.3.259.09.1.EN

Table 2.1. Information and warning stickers

Item	Sticker	Meaning / Catalog number
1		Machine type sticker T672ECO 619N-00000002
2		Caution! Before starting work, read the <i>User's Manual</i> . 70N-00000004
3		Before starting any servicing or repair work, switch off the tractor engine and remove the ignition key. Secure the tractor cab against unauthorized access. 70N-00000005
4		Before starting any servicing or repair work, switch off the tractor engine and remove the ignition key. 29N-00000030
5		Caution. Danger of electric shock. When unloading the trailer keep a safe distance from overhead power lines. 58N-00000020

Item	Sticker	Meaning / Catalog number
6		<p>Danger of being crushed. It is forbidden to carry out repair or maintenance works under a loaded and/or unsupported load box.</p> <p style="text-align: right;"><i>29N-0000029</i></p>
7		<p>Regularly check the tightness of wheel nuts and other bolted connections.</p> <p style="text-align: right;"><i>104N-00000006</i></p>
8		<p>Regularly carry out trailer lubrication activities according to the schedule.</p> <p style="text-align: right;"><i>104N-00000004</i></p>
9		<p>A sticker marking the hose supplying the hydraulic brake system.</p> <p style="text-align: right;"><i>187N-00000033</i></p>
10		<p>Hydraulic supply hose for the tip system.</p> <p style="text-align: right;"><i>29N-0000029</i></p>
12		<p>Position of the valve controlling the operation of the hydraulic tipping system (1 or 2 trailers)</p>
14		<p>Tire pressure.⁽¹⁾</p> <p style="text-align: right;"><i>37N-0000007</i></p>
15		<p>Manufacturer's website address.</p> <p style="text-align: right;"><i>614N-0000001</i></p>

⁽¹⁾ – the pressure depends on the used tires

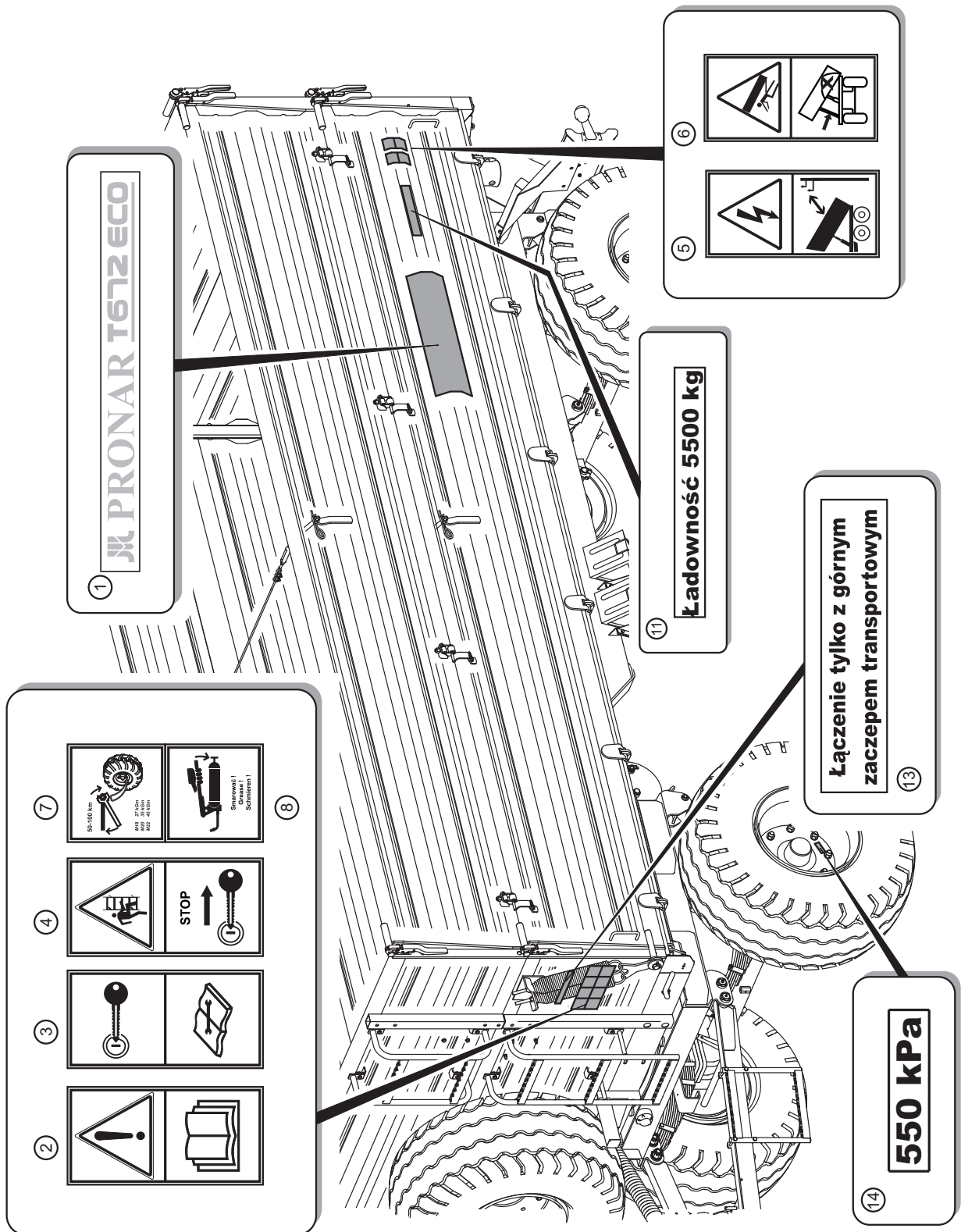

619-F.03-1

Figure 2.3 Arrangement of information and warning stickers

CHAPTER 3

CONSTRUCTION AND PRINCIPLE
OF OPERATION

3.1 TECHNICAL CHARACTERISTICS

Table 3.1. Basic technical data

Content	Unit	T672ECO
Dimensions		
Length	mm	6,636
Width	mm	2,390
Height	mm	2,171
Wheel track	mm	1,700
Internal dimensions of box		
Length	mm	4,440
Width, front	mm	2,190
Width, back	mm	2,240
Height	mm	500 + 500
Performance parameters		
Load capacity	m ³	4.9
Loading area	m ²	9.7
Loading surface lift	mm	1,128
Tipping angle of the load box - backwards / sideways	deg	50 / 46
Weight and load capacity		
The trailer's karb weight	kg	2,280 ⁽¹⁾
Permissible gross weight	kg	8,000
Allowed package	kg	5,720 ⁽¹⁾
Other information		
Min. tractor power	kW/KM	34.4 / 46.8
Electrical system voltage	V	12
Permissible design speed	km/h	40
Noise level	dB	below 70
Tipping cylinder oil demand	L	13
Nominal pressure of pneumatic system	bar	200

⁽¹⁾ depending on the equipment (completion)

Tire information is provided at the end of the publication in APPENDIX A.

3.2 GENERAL CONSTRUCTION

DIMENSIONS

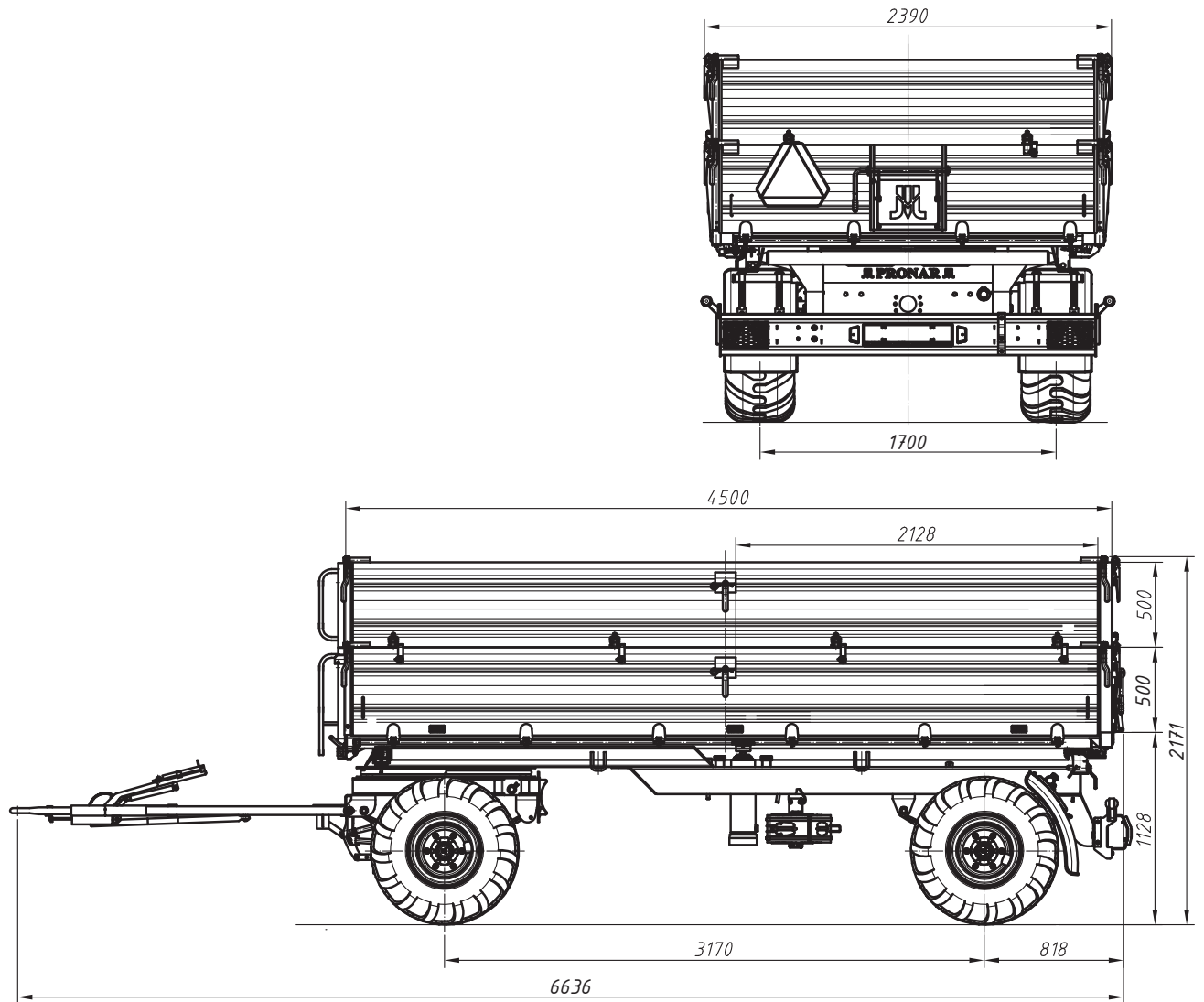

619-E.02-1

Figure 3.1 Overall dimensions of the trailer

TRAILER CHASSIS

The trailer chassis consists of the units specified in figure (3.2). The lower frame member (10) was welded to the left longitudinal member. In the central part there are

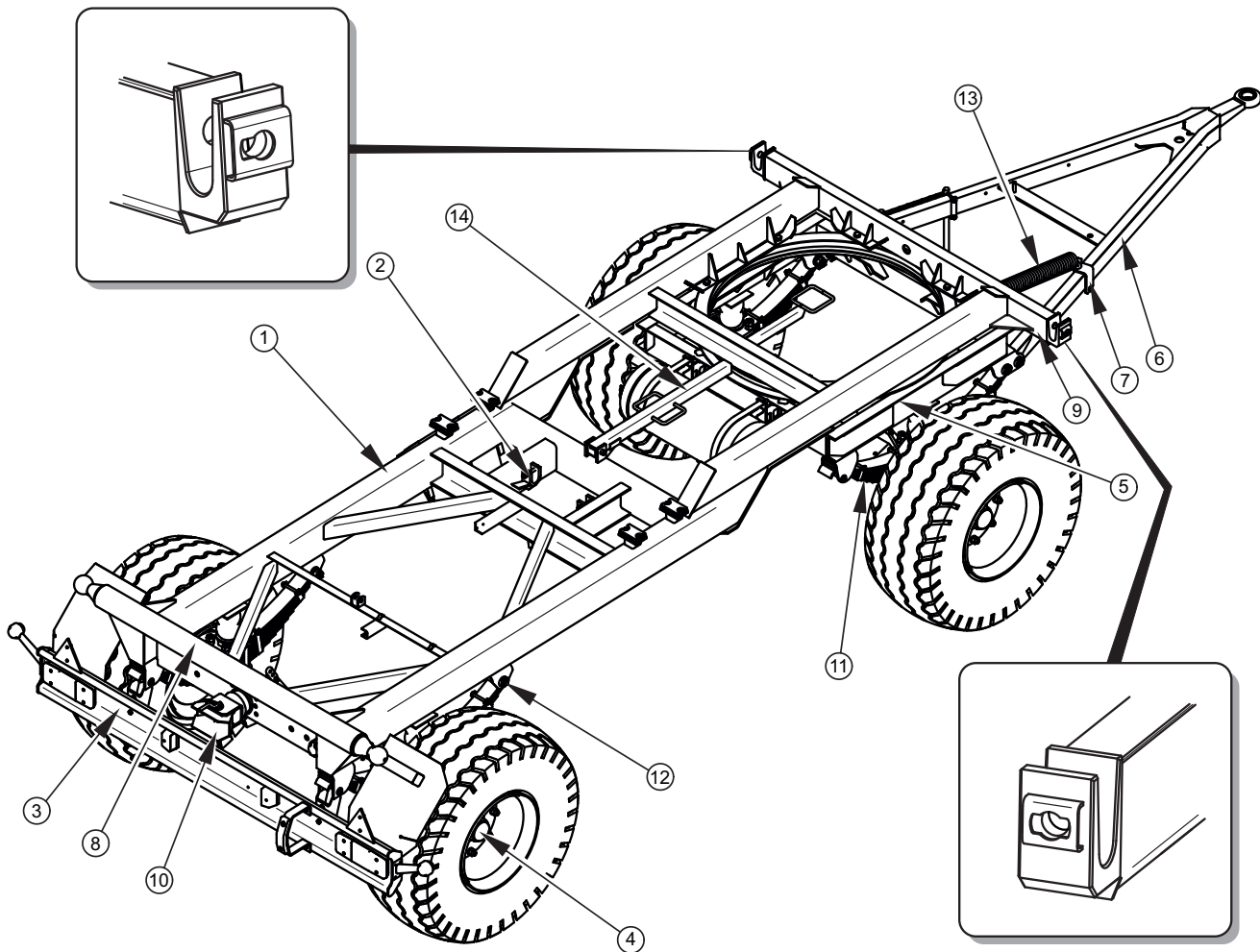

619-G.01-1

Figure 3.2 Trailer chassis

- (1) bottom frame (2) tipping cylinder housing (3) rear beam
 (4) driving axle (5) turntable frame (6) drawbar (7) spring catch
 (8) lighting beam (9) front beam (10) drawbar
 (11) parabolic spring (12) spring pin (13) spring (14) transmission support

(1) is a welded structure made of steel sections. The basic load-bearing elements are two longitudinal members connected with crossbars. The parking brake mechanism

sockets (2) for mounting the hydraulic tipping cylinder. The load box support (14) serves to protect the load box against falling during maintenance work. In the

ADVICE

Drawings describing the construction of the trailer show an example equipment configuration. Detailed information on all options can be found in the Equipment chapter.

rear part of the lower frame there is a rear beam (3), ended with ball pins. The design of the foundation of the upper frame and the locking method enables tipping of the load box sideways and backwards. The front beam (9) of the lower frame, on the right and left side have been welded with brackets for mounting the upper frame. The shapes of the holes in the handles are designed so that the pins connecting the upper frame to the lower frame are placed in the right seats.

In the rear part of the chassis there is a lighting beam (8), to which mainly electrical equipment is attached. Above the lighting beam, as an option, you can mount a rear hitch designed for aggregating

a second two-axle trailer. The 33 mm diameter pin is adapted to be connected with a 40 mm tie rod.

The trailer suspension consists of driving axles (4) and parabolic springs (11), fastened to the turntable frame (5) at the front, and to the lower frame (1) at the rear by means of spring pins (12). The axles are attached to the springs with a spring plate and U-bolts. They were made of a square bar terminated with pins, on which road wheel hubs are mounted on the tapered roller bearings. These are single wheels equipped with calliper brakes actuated by mechanical cam expanders.

In the front of the trailer there is a turntable frame (5) to which the V-type drawbar (6) or Y-type drawbar (15) can be mounted. The diameter of the drawbar eye is 40mm. The height of the drawbar can be adjusted by using the sliding hitch (7) connected to the drawbar spring (13).

ADVICE

In the trailer version with overrun brake, the (normal) axles are replaced with overrun axles equipped with a mechanism that secures the locking of the vehicle wheels when reversing.

G.3.3.619.02.1.EN

3.3 LOAD BOX

The trailer's load box consists of: upper frame (1) - figure (3.3) with welded steel floor, side walls (2), front wall (4) and rear wall (5) with a height of 500 mm. Optionally, the trailer can be equipped with a set of extensions (3) with a height of 500 mm. Side walls and side extensions can be made in

a version with a fastening rope.

The load box is mounted in the sockets of the rear beam and the front lower frame.

The selected direction of tipping is realized by placing the tipping pins in properly profiled socket holes, whose construction prevents their incorrect placement by the

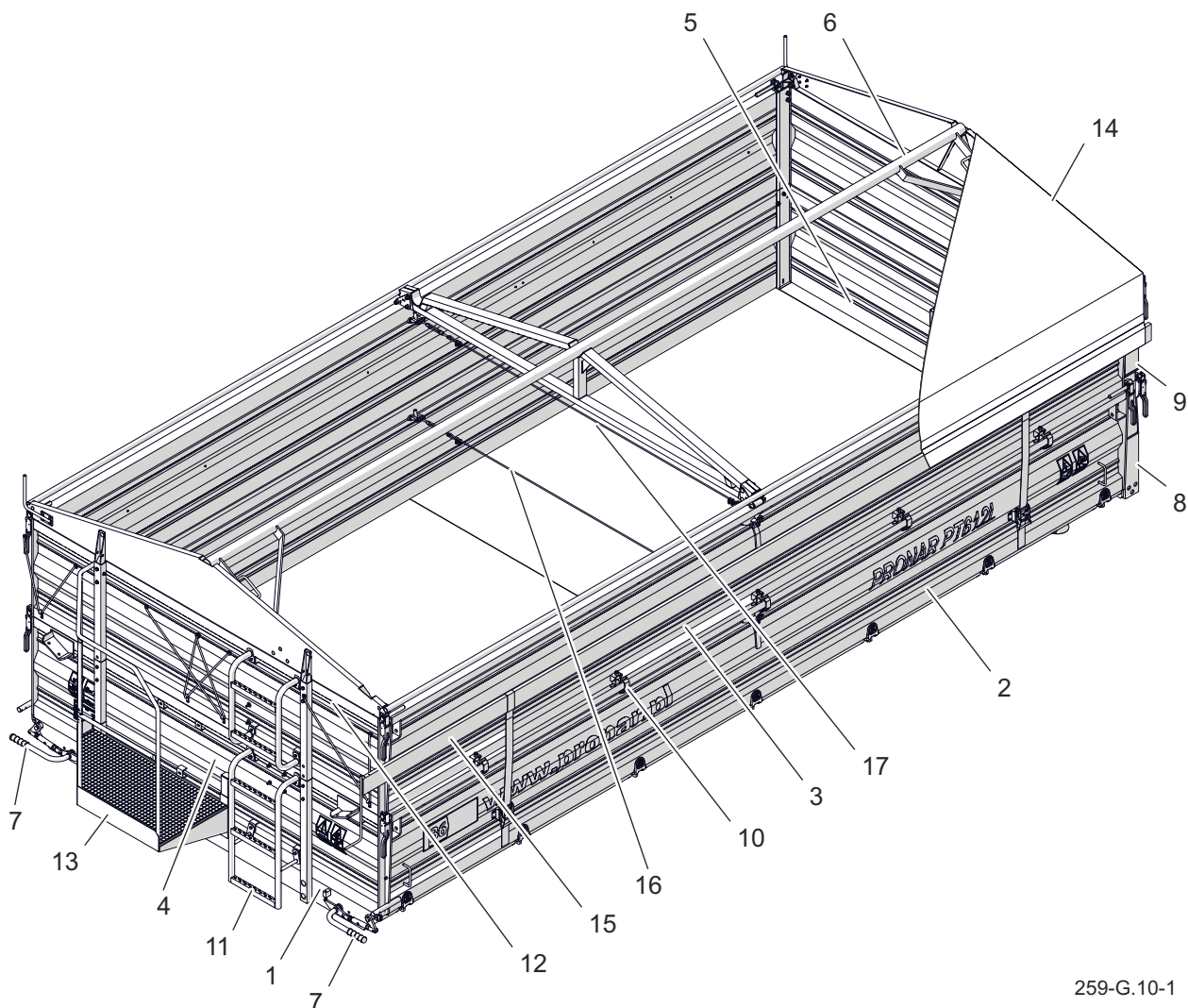

259-G.10-1

Figure 3.3 Load box

(1) upper frame, (2) side wall, (3) set of extensions, (4) front wall, (5) rear wall, (6) folding frame, (7) lever for closing the side walls, (8) rear wall post, (9) rear post extensions, (10) upper hinge, (11) bottom ladder, (12) upper ladder, (13) balcony, (14) tarpaulin, (15) rolling beam, (16) wall fastening cable, (17) cable fastening the extensions

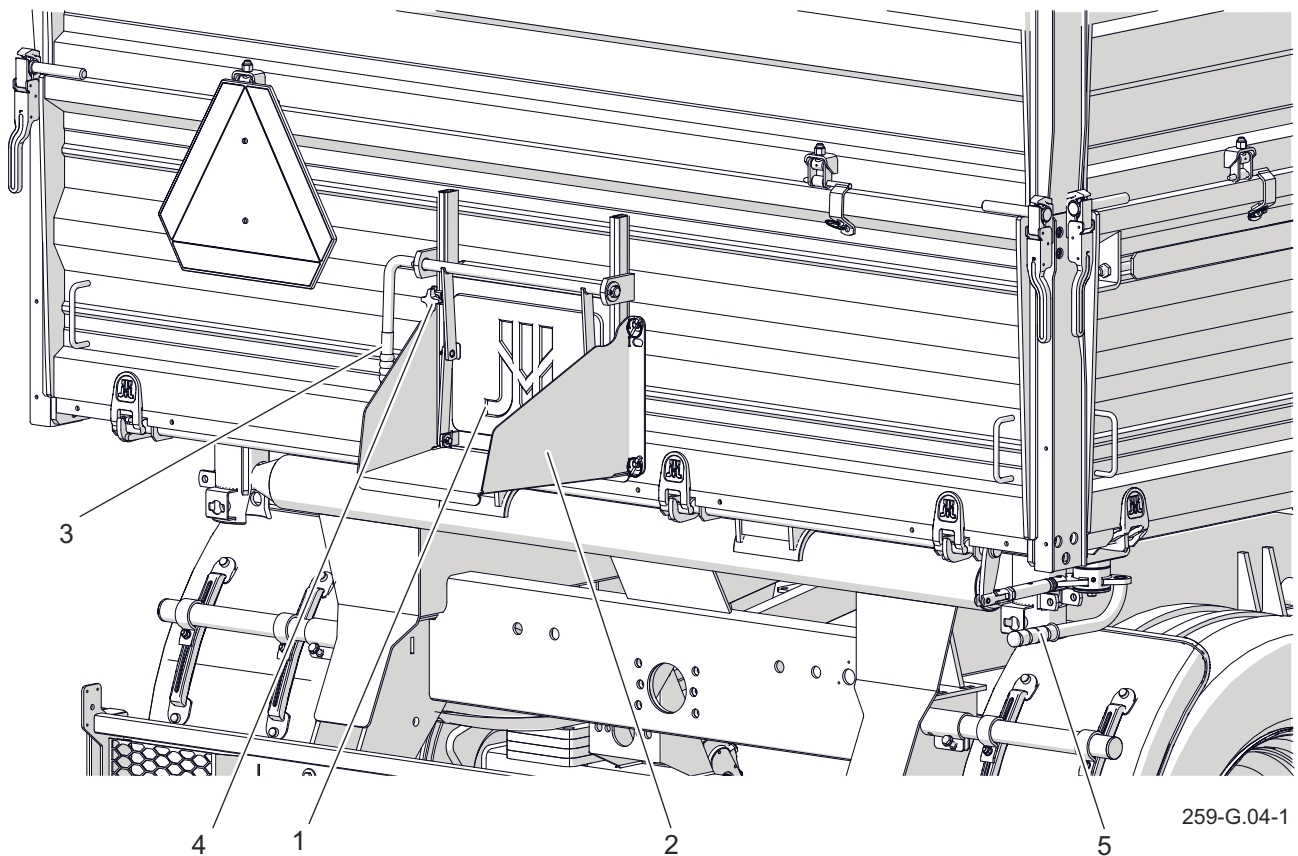

Figure 3.4 Back wall

(1) slide, (2) chute, (3) lever, (4) locking screw, (5) rear wall closing lever

trailer operator.

The side walls of the load box are fastened with locks in the wall and front, as well as locks in the rear pillars (8). In the lower part, the walls are blocked by means of locking hooks located on the left and

ADVICE

Drawings describing the construction of the trailer show an example equipment configuration. Detailed information on all options can be found in the Equipment chapter.

right side of the upper frame (1). The rear wall (5) is mounted in the rear pillar locks and is locked by means of locking hooks

located in the rear part of the upper frame. Closing and opening the side walls is done with the help of two levers (7) located on the front beam of the upper frame. In case of the rear wall, locking and opening is carried out using the lever (5) - see figure (3.4) on the right side of the load box.

The extensions are attached like the walls of the load box. The upper extension pins are fastened with front extension and rear post locks (9). The extensions are connected to the walls with hinges (10).

The entrance ladders (11) and (12) are attached to the wall and front extension. From the inside of the wall and the front extension, additional folding steps are

bolted to facilitate access to the load box. The trailer's additional equipment is a tarpaulin (14) with a rolling beam (16) mounted with a folding frame (6). The balcony (12) serves as a platform for the tarpaulin operator. In order to allow more precise unloading of loose materials, a slide (1) has been

placed in the rear wall - figure (3.4), which is lifted by means of a lever (3). The gate valve in the upper position and during the passage must be secured by tightening the locking screw (4). The rear chute (2) can be installed as additional equipment on the trailer.

G.3.3.619.02.1.EN

3.4 SERVICE BRAKE

Depending on the version, the trailer is equipped with one of three types of service brake:

- overrun brake,
- 2-wire conduit pneumatic system - figure (3.7).
- 2-wire pneumatic system with ALB - figure (3.8).

The service brake is activated from the driver's cab by pressing the tractor brake pedal. The task of the control valve used (1) - figure (3.6) in pneumatic systems is to activate the trailer's brakes simultaneously with the tractor's brake on. In addition, in the event of an unforeseen disconnection of the hose between the trailer and the tractor, the control valve automatically applies the machine's brake.

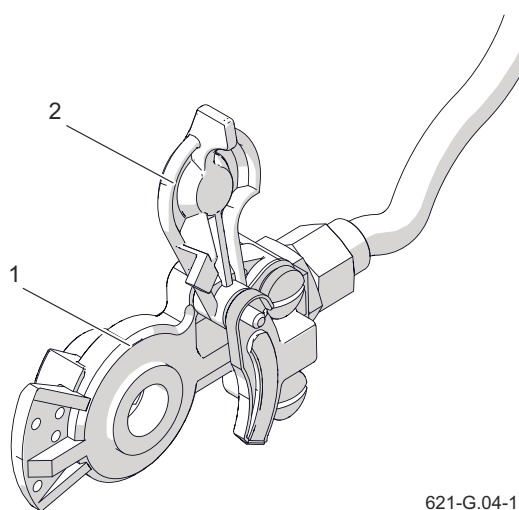

Figure 3.6 Pneumatic connections

- (1) connection body
(2) connection body

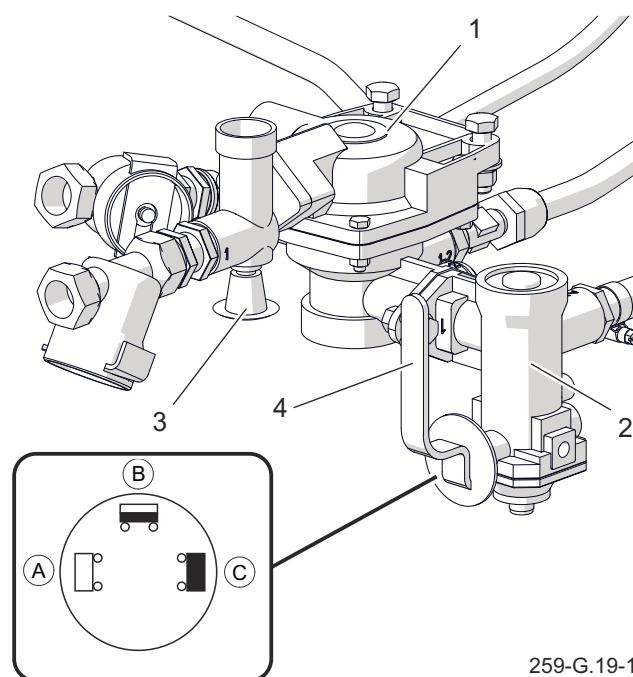

Figure 3.5 Control valve and braking force regulator

- (1) control valve (2) brake force regulator (3) brake release button (4) setting lever
(A) 'UNLOADED' position
(B) 'HALF LOAD' position
(C) 'FULL LOAD' position

The trailer is braked (automatically braked) by pressing the button (3) fully. The valve used has a brake release system, used when the trailer is disconnected from the tractor. After connecting the air line to the tractor, the release device automatically adjusts to the position enabling normal operation of the brakes.

The three-band braking force regulator (2) used in pneumatic systems adjusts the braking force depending on the setting.

Switching to the appropriate operating mode is done manually by the machine operator before starting the journey using the lever (4).

Three work positions are available: A - 'No load', B - 'Half load' and C - 'Full load'.

PNEUMATIC CONNECTIONS

Pneumatic connections are equipped with covers (2), protecting them against dirt and dust entering the system. They are made of coloured plastic (black connector - supply

and control air of a 1-wire system, red connector - supply air of a 2-wire system, yellow connector - control air of a 2-wire system). The connectors are made in accordance with the recommendations of DIN ISO 1728, which makes it impossible to mistakenly connect the connectors to agricultural tractor sockets. After uncoupling the trailer, pneumatic connections should be placed in sockets prepared for this purpose, located on the drawbar.

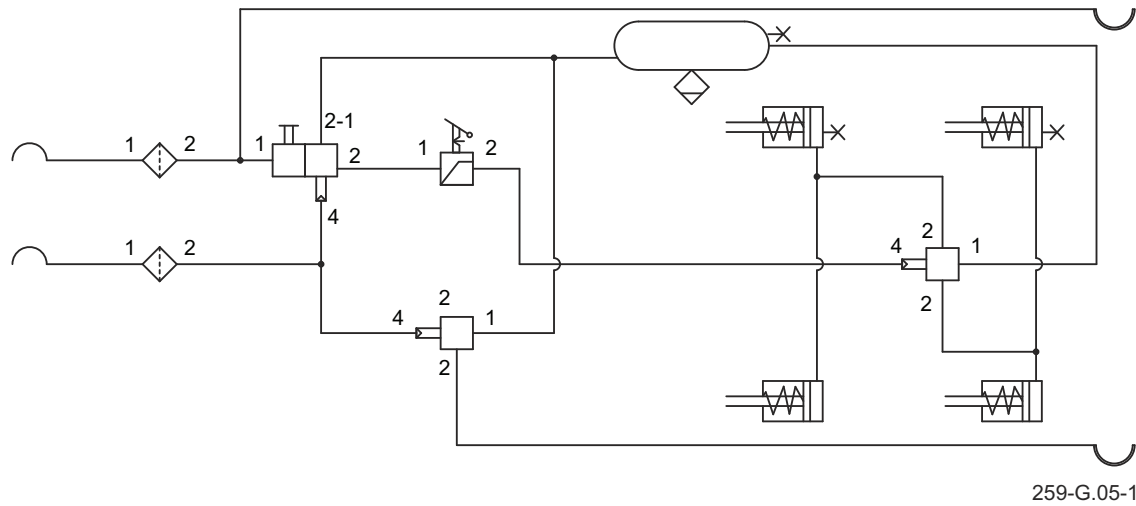

Figure 3.7 Diagram of a 2-wire pneumatic braking system

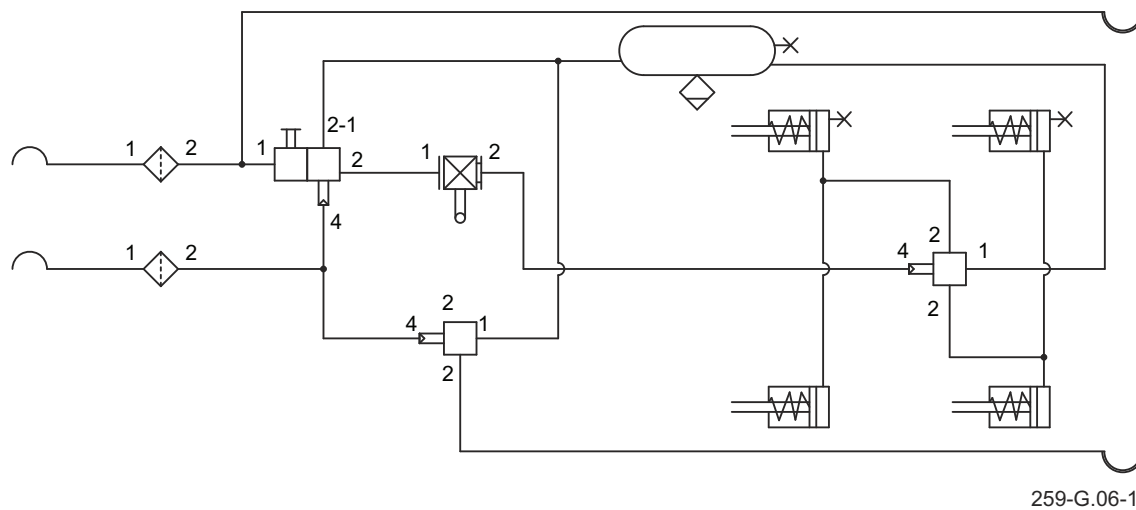







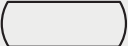

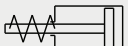



Figure 3.8 Diagram of the ALB 2-wire pneumatic braking system

Table 3.2. List of symbols used in the diagrams

Symbol	Description
	Pneumatic connection, plug
	Pneumatic connection, socket
	Drainage valve
	Main control valve
	Relay valve
	Automatic braking force regulator
	Manual braking force regulator
	Wire connection
	Air tank
	Pneumatic brake cylinders
	Hydraulic brake cylinders
	Control valve (connector)
	Air filter

G.3.3.619.02.1.EN

3.5 HYDRAULIC TIPPING SYSTEM

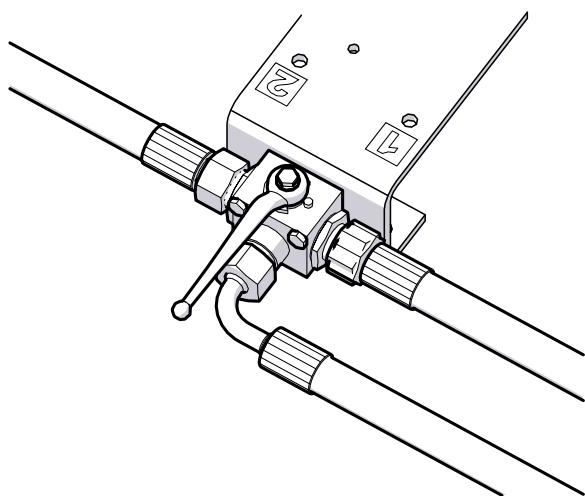

619-G.09-1

Figure 3.9 Three-way tipper valve

The hydraulic tipping system is used for automatic unloading of the trailer by tilting the load box backwards or on sides. The hydraulic system of the unloading mechanism is supplied with oil from the tractor's hydraulic system. The tractor's external hydraulic oil distributor is used to control the lifting of the load box.

In the trailer, the installation consists of two independent circuits:

- circuit (A) - for supplying the hydraulic cylinder of the first trailer,
- circuit (B) - to supply the second trailer hydraulic cylinder in case of connecting two trailers to the tractor.

A three-way valve is used to turn on these circuits (Fig. 3.9). The lever on this valve can occupy 2 positions:

ADVICE

The trailer hydraulic braking system was filled with L-HL32 Lotos hydraulic oil.



CAUTION

The pressure of the electrohydraulic brake valve (1) - figure (3.11) is set by the manufacturer and it is forbidden to regulate it when using the trailer.

- 1 - trailer tipping open circuit - circuit (A),
- 2 - second trailer tipping circuit open - circuit (B).

A sticker (8) has been placed on the connecting pipe, in the vicinity of the plug (4), which identifies the hydraulic feed pipe of the tipping system.

The hydraulic system has a shut-off valve (3) controlled by a cable (6) to limit the swing angle of the load box.



CAUTION

The length of the control cable is set by the Manufacturer and it is forbidden to adjust it by the User.

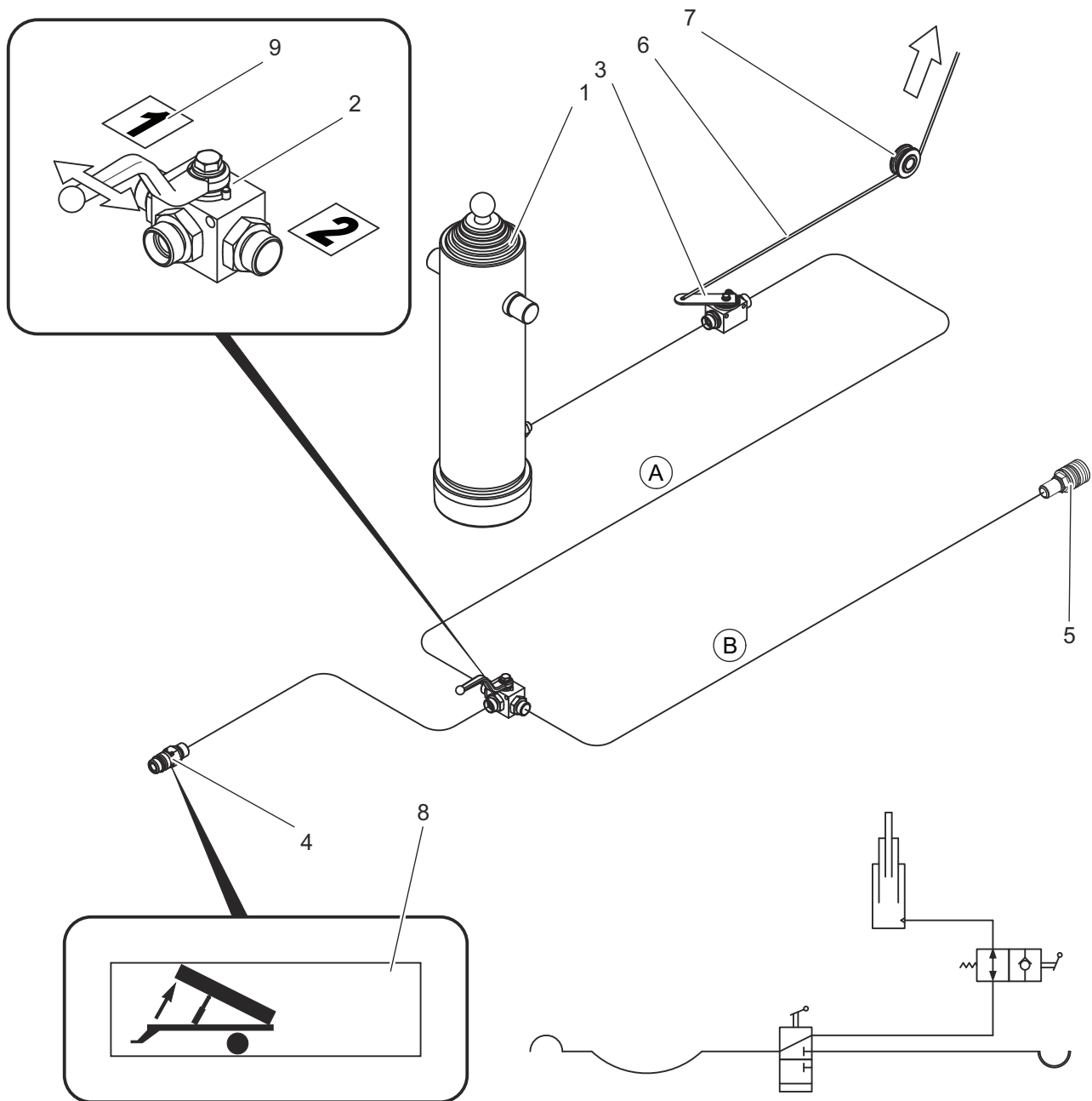

259-G.11-1

Figure 3.10 Construction and diagram of the hydraulic tipping system

(1) telescopic cylinder, (2) three-way valve, (3) shut-off valve, (4) quick coupling - plug, (5) quick coupler - socket, (6) control cable, (7) guide roller, (8), (9) information stickers

G.3.3.619.05.1.EN

3.6 PARKING BRAKE

The parking brake is used to immobilize the trailer during parking. The brake crank mechanism body (1) is welded to the bracket located to the left longitudinal member of the lower frame.

The steel cable (2) is guided through the wheels (3), connects the crank mechanism through the arms (5) to the expander levers of the rear axle (6) - figure (3.11).

Tensioning the cables (turning the crank mechanism clockwise) causes swinging of the expander levers, which by opening the brake shoes immobilize the trailer.

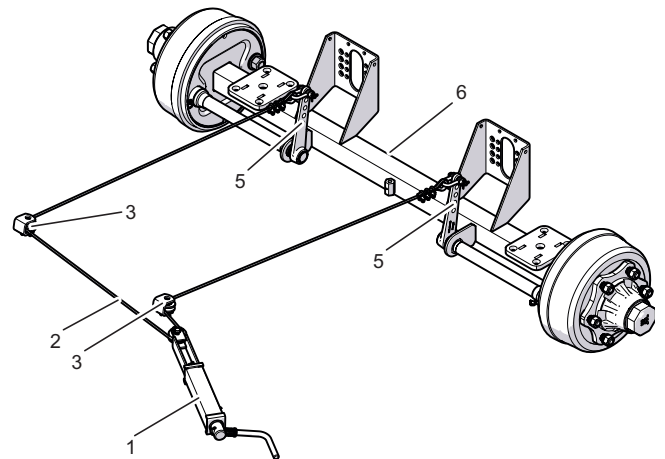

619-G.12-1

Figure 3.11 Parking brake
(1) crank mechanism, (2) steel cable
(3) guide wheel, (4) brake expander lever,
(5) brake lever arm, (6) travel axle

G.3.3.619.06.1.EN

3.7 ELECTRICAL LIGHTING INSTALLATION

The trailer's electrical installation is adapted to be supplied from a 12 V DC source. Connecting the hook trailer's electrical system to the tractor should be made using a suitable connection cable, which is included in the machine's equipment. Electrical components of the lighting system

CAUTION

The machine lamps work only when the trailer is connected to the agricultural tractor and the position lights are on.

in the standard version of the trailer are shown in figure (3.13).

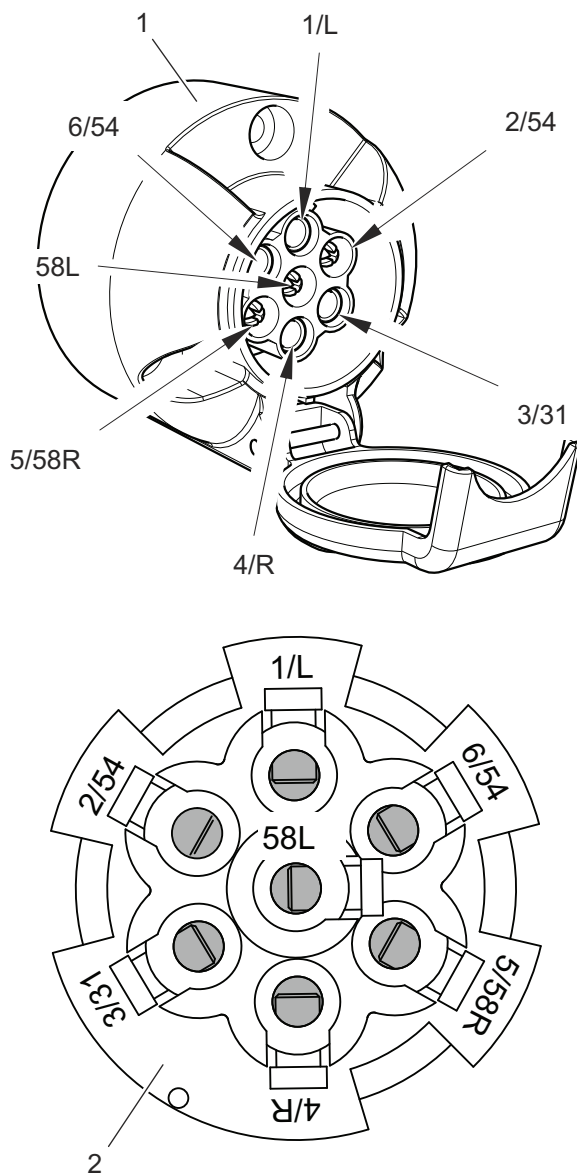

Table 3.3. Markings of connection socket

Marking	Function (wire colour)
1/L	Left indicator (yellow)
2/54G	Not used
3/31	Weight (white)
4/R	Right indicator (green)
5/58R	Rear right position light (brown)
6/54	STOP light (red)
7/58L	Rear left position light (black)

Figure 3.12 Connection socket

(1) socket

(2) beam side view

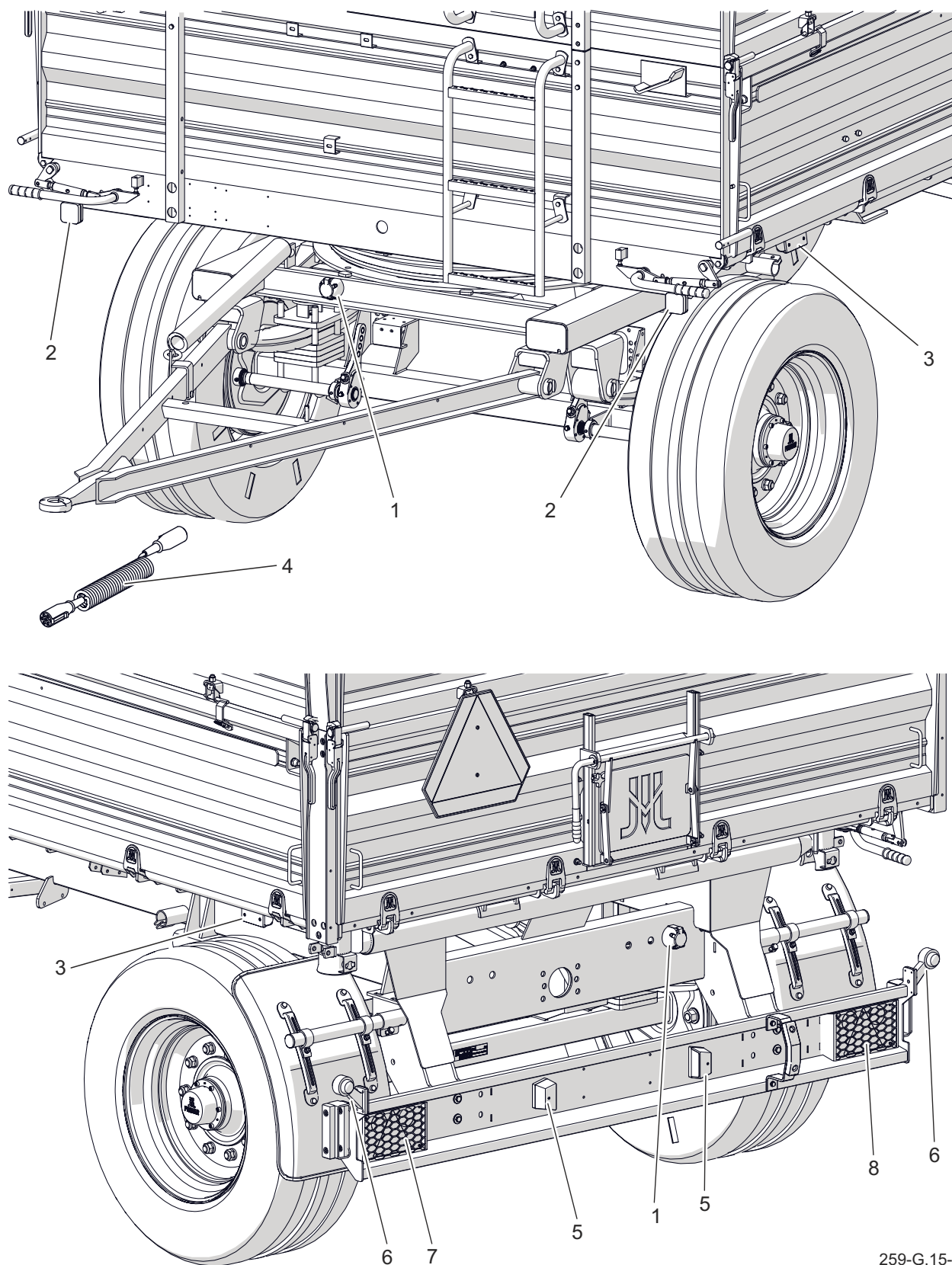

259-G.15-1

Figure 3.13 Construction of electrical installation

(1) 7pin socket, (2) front position lamp, (3) side position lamp, (4) 7pin-7pin connection cable, (5) license plate lamp, (6) clearance lamp, (7) rear left multifunctional lamp , (8) rear right multifunctional lamp

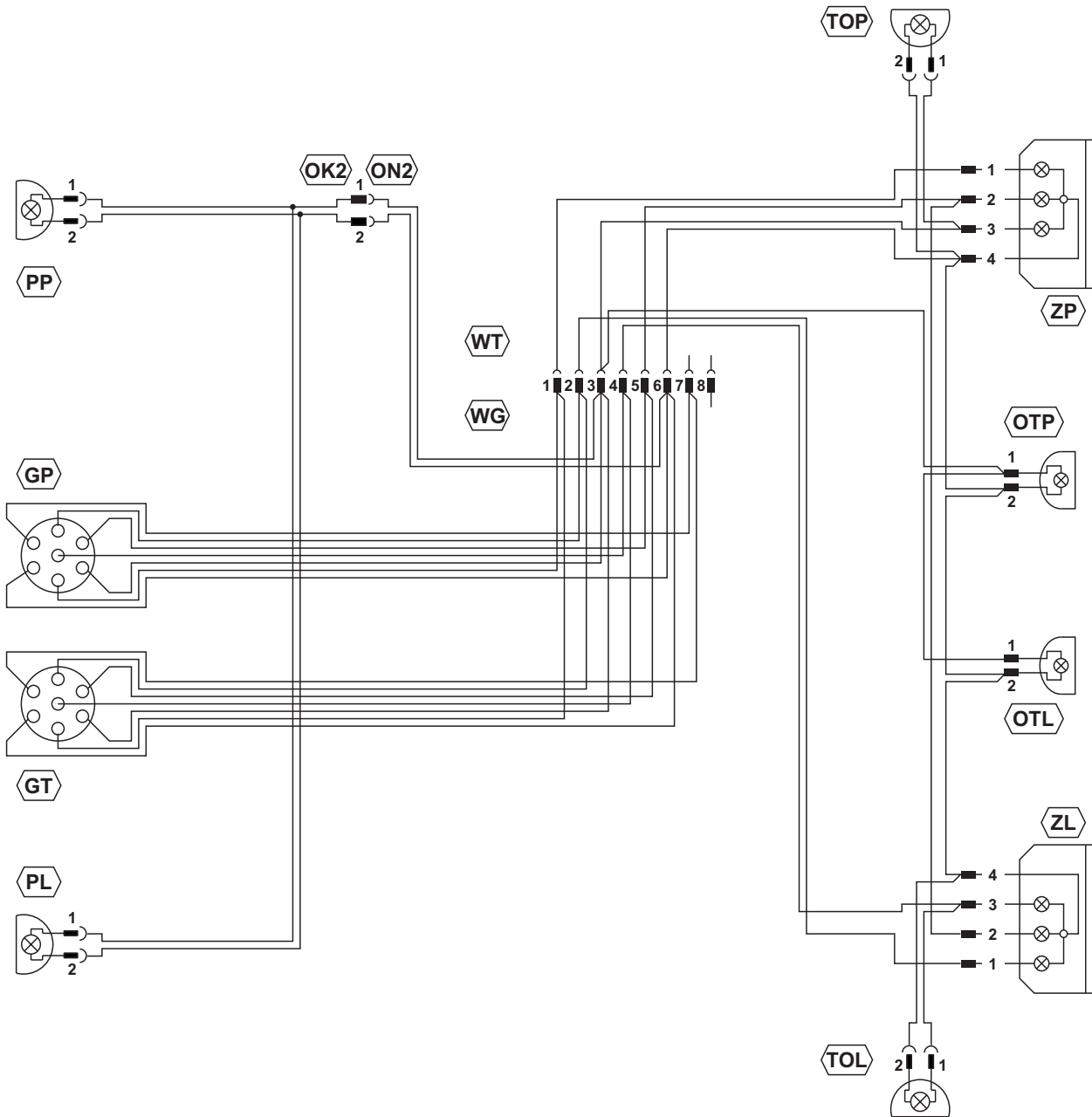

619-E.01-1

Figure 3.14 Electrical system schematic diagram

Table 3.4. List of electrical components markings

Symbol	Function
GP	Front 7 poles socket
GT	Rear 7 poles socket
PP	Front right plate lamp
PL	Front left plate lamp
ZP	Multifunctional rear right lamp
ZL	Multifunctional rear left lamp
OT	Board lighting lamp
OTP, OTL	Board lighting lamp
TOL	Clearance rear left lamp
TOP	Clearance rear right lamp
OBP	Clearance right lamp
OBL	Clearance left lamp

Table 3.5. Colour coding of wires

Symbol	Colour
B	White
C	Black
K	Red
N	Blue
P	Orange
T	Green
O	Brown
Z	Yellow
C/T	Black-green

G.3.3.619.08.1.EN

CHAPTER 4

RULES OF USE

4.1 ADJUSTING THE POSITION OF THE DRAWBAR

The drawbar position is adjusted by moving the spring hitch (2) in the selected direction. The spring tension (1) does not change with this operation. The spring is only intended to maintain the set height of the drawbar. In many solutions of the upper transport hitch of agricultural tractors, it is possible to adjust its height to the hitch of machines.

It is recommended that the trailer's drawbar be set as level as possible or with a slight upward pull.

ADVICE

It is recommended that the trailer's drawbar be set as level as possible or with a slight upward pull.

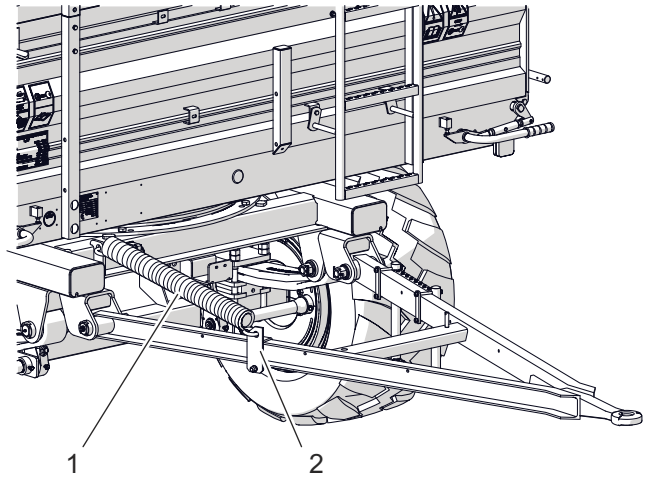

259-H.01-1

Figure 4.1 Adjusting the position of the drawbar

(1) spring, (2) spring catch

H.3.3.259.01.1.EN

4.2 CONNECTING AND DISCONNECTING OF THE TRAILER

CONNECTING OF THE TRAILER



CAUTION

After connecting the trailer, perform a daily inspection of the machine before driving.

The external examination of the machine without connecting it to the tractor will not allow verification of its technical condition.

Detailed information on inspections can be found in chapter 5.

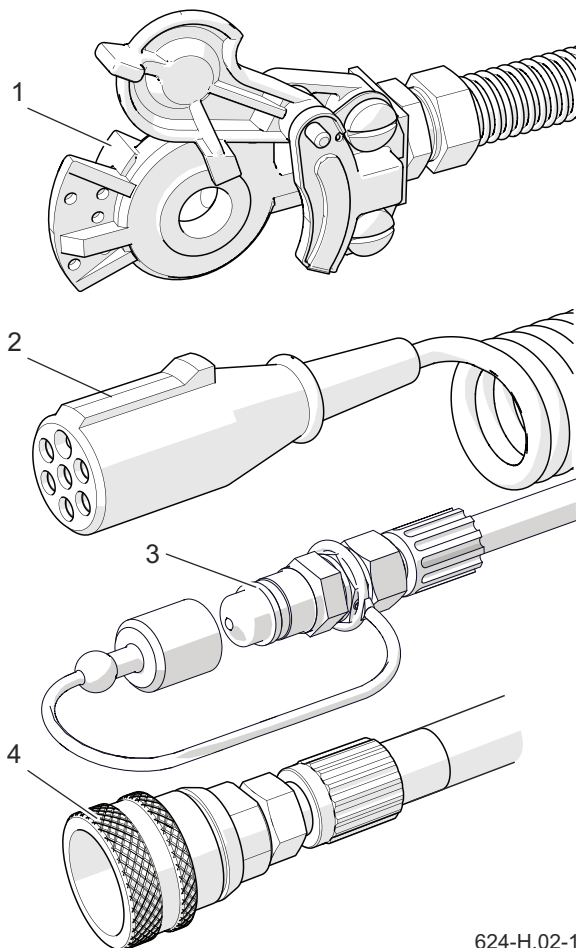

624-H.02-1

Figure 4.3 Trailer connections
 (1) pneumatic brake plug (red, yellow - 2-wire installation, black 1-wire installation),
 (2) 7pin electric plug, (3) hydraulic plug,
 (4) hydraulic brake socket

The trailer may be connected to an agricultural tractor if all connections (electrical, pneumatic, hydraulic) in the agricultural tractor are in accordance with the trailer manufacturer's requirements specified in the table Requirements of the agricultural tractor .

If the tractor does not have such sockets or the sockets are of a different type then assembly should be carried out by a qualified person in accordance with the recommendations of the tractor manufacturer.

PREPARATION

- Ensure that the trailer is immobilized

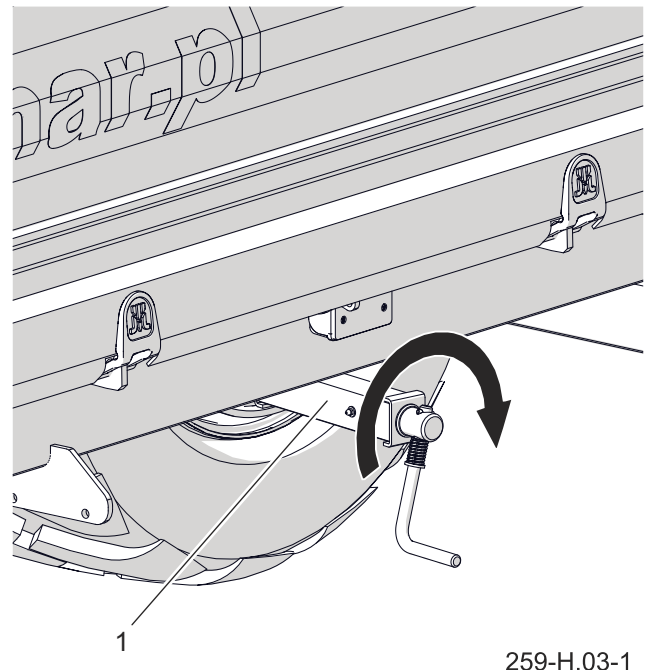

259-H.03-1

Figure 4.2 Parking brake
 (1) brake mechanism

with parking brake.

Turn the brake mechanism clockwise as far as it will go - figure (4.3).

Raise the parking brake lever located on the drawbar - if the trailer is equipped with an overrun brake.

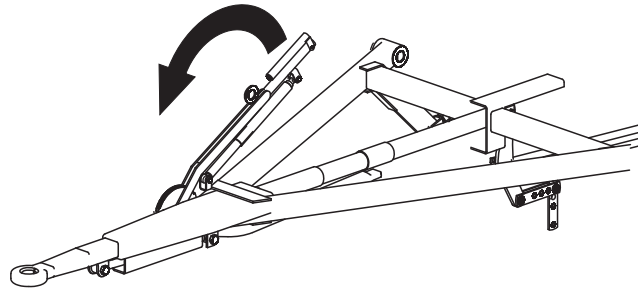

619-H.01-1

Figure 4.4 Parking brake for overrun drawbar

- Make sure that blocking wedges are placed under one trailer wheel.
- Position the agricultural tractor directly in front of the drawbar eye.
- Set the drawbar eye or the height of the upper transport hitch on the tractor at such a height that it is possible to connect the machines.

Refer to chapter (4.1). **CONNECTING THE TRAILER TO THE TRACTOR HITCH**

- Reverse the tractor, connect the trailer to the hitch, check the coupling safety device protecting the machine against accidental unhitching.
- If an automatic coupling is used in the tractor, make sure that the aggregation operation is completed and the drawbar eye is secured.
- Turn off the tractor engine and remove the keys from the ignition. Secure tractor with parking brake. Close the tractor cabin and secure it against unauthorized access.



DANGER

During hitching, unauthorized persons must not be between the trailer and the tractor. The agricultural tractor operator when connecting the machine should take particular care during work and make sure that unauthorized persons are not in the danger zone during coupling.

When connecting the hydraulic or pneumatic conduits to the tractor, make sure that the tractor and the trailer installations are not under pressure.

When coupling, take special care to ensure proper visibility.

After completing the coupling check the safety of the coupling bolt.

CONNECTING OF THE BRAKING SYSTEM

- Depending on the trailer configuration, connect the braking system connectors to the appropriate tractor sockets.
- Connect the 2-wire pneumatic system lines.

The first is to connect the yellow plug to the yellow socket on the tractor, and then to the red plug to the red socket on the tractor. After connecting the second

conduit, the brake release system will switch to normal operation mode (disconnection or interruption of the air conduits causes the trailer control valve to automatically move to the machine braking position).

- If the brakes do not react after connecting the pneumatic hoses, this may indicate a low pressure in the tank. For the system to work, it must be filled with the correct pressure.
- Connect the hydraulic brake system hose terminated in the socket (4) - figure (4.3).

When connecting the trailer with the overrun brake, it is only necessary to adjust the height of the drawbar eye in relation to the transport hitch, connect the hydraulic tipping system and the electrical installation cable.

CONNECTING OF THE HYDRAULIC SYSTEM

- Depending on the configuration of the trailer, connect the hydraulic system connections (3) - figure (4.3) to the appropriate tractor sockets.

The cables used to connect

individual systems have been marked with labels.

CONNECTING THE LIGHTING ELECTRICAL INSTALLATION

- Connect the main cable (2) - figure (4.3) supplying the lighting electrical installation (7-pin).

ADDITIONAL INFORMATION

- After completing the connection of all cables make sure that they will not get entangled in moving parts of the tractor or trailer during operation. Secure cables if necessary.
- Perform daily inspection of the trailer.
- If the trailer is functional, you can start working.
- Immediately before driving, remove the wheel chocks and release the machine parking brake.

Turn the crank handle anti-clockwise as far as it will go.



CAUTION

Pay attention to the compatibility of oils in the tractor hydraulic system and in the hydraulic system of the trailer system.

**CAUTION**

If the trailer is parked for a long time, it may turn out that the air pressure in the pneumatic braking system is insufficient to release the brake shoes. In this case, after starting the tractor and the air compressor, wait until the air in the pneumatic tank is topped up.

**DANGER**

The use of defective trailers is forbidden.

DISCONNECTING THE TRAILER

- Place the trailer on a hard and flat surface.
- Switch off the tractor engine and remove the ignition key, secure the tractor with the parking brake.
- Block the trailer with parking brake.
- Place blocking wedges under one

**CAUTION**

After completing the coupling, secure the hydraulic, braking and electrical wiring in such a way that they do not become entangled in the moving parts of the agricultural tractor during travel and are not exposed to kinking or cutting during turning.

**DANGER**

Before disconnecting wires and drawbar eye, close tractor cab and secure it against unauthorized access. The tractor engine must be turned off.

wheel of the trailer, one in the rear and the other in front of the wheel.

- Disconnect all cables in turn. Secure the ends of the hydraulic hoses by fitting the rubber caps on the hydraulic connectors.
- Place the cables in the sockets on the support located on the drawbar.
- Release the drawbar eye, start the tractor and drive away with the tractor.

**CAUTION**

When disconnecting the pneumatic conduits of a 2-wire system, first disconnect the conduit marked red and then the conduit marked yellow.

ADVICE

Before disconnecting the hydraulic hoses, reduce the pressure in the hoses. For this purpose move the lever of the distributor of the external hydraulic system of the tractor to the floating position with the tractor engine running.

H.3.3.259.03.1.EN

4.3 CONNECTING AND DISCONNECTING OF A SECOND TRAILER

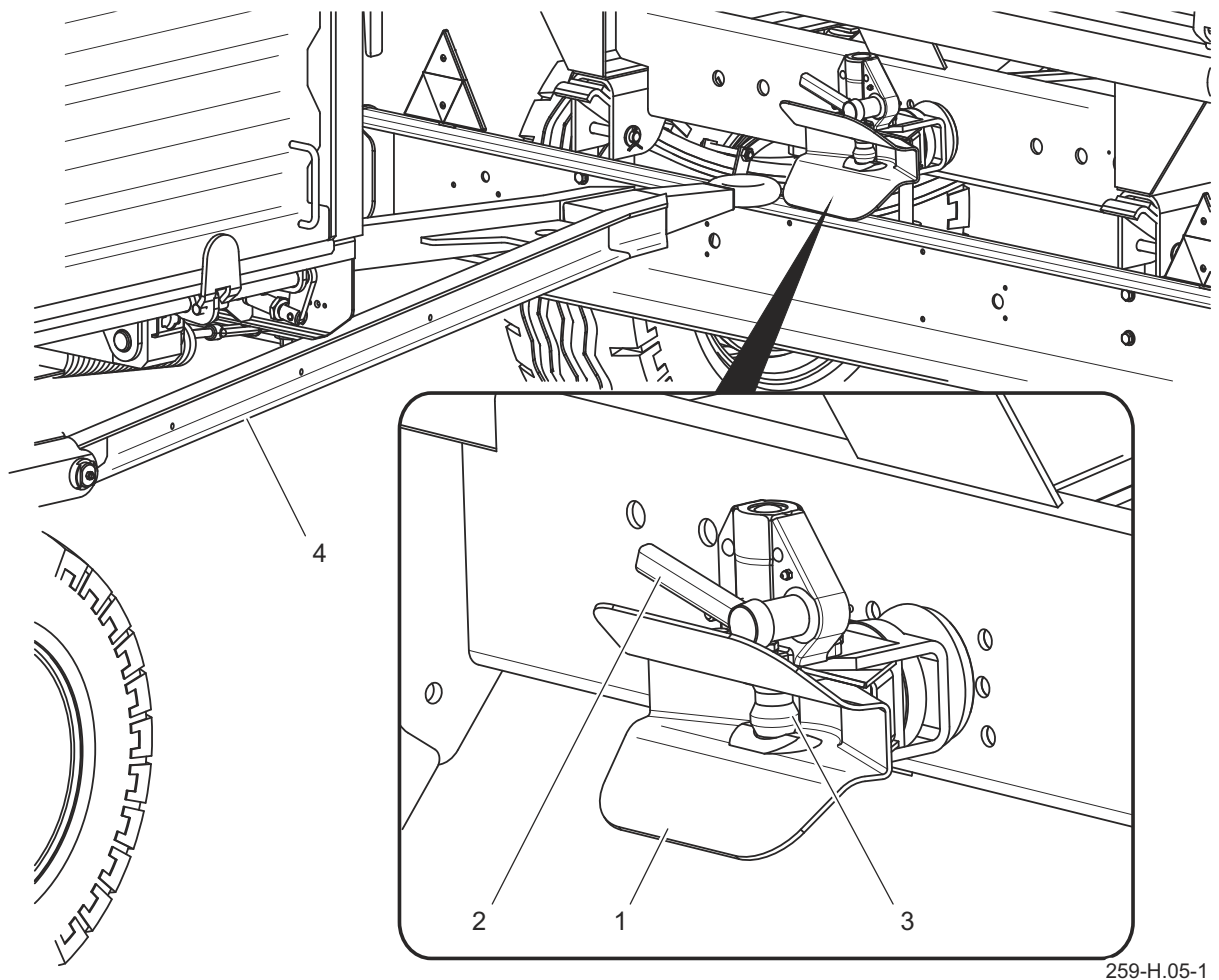

259-H.05-1

Figure 4.5 Connecting of the second trailer

(1) hitch body, (2) lifting handle for automatic hitch pin, (3) hitch pin, (4) second trailer drawbar

A second trailer may only be connected if it is a machine built on a two-axle chassis and if it meets all the requirements of Chapter 1.

Aggregating a second trailer with a set requires experience in steering an agricultural tractor with a trailer. It is recommended that when coupling the second trailer use the help of another person who will inform the tractor operator about the

course of the operation.

SECOND TRAILER REQUIREMENTS

- Before connecting the second trailer, check whether the oil in the hydraulic systems of both trailers can be mixed together.
- Position the tractor with the first trailer attached straight ahead of the second trailer's drawbar.
- Immobilize the second trailer with the

parking brake.

- Remove the cotter pin and remove the coupling pin on the first trailer.

If the automatic rear hitch is used in the trailer, the bolt should be lifted up using the handle (2) - figure (4.6).

- Adjust the height of the drawbar of the second trailer so that the machines can be coupled.
- When reversing the tractor, drive the rear hitch of the first trailer onto the drawbar of the second trailer. *In the case of an automatic drawbar, make sure that the aggregation operation*

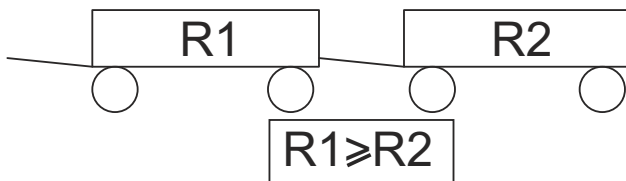

259-H.06-1

Figure 4.6 Permissible weights of trailers



DANGER

When connecting / disconnecting nobody may be between the trailers. Take special care. The person who helps aggregate the machine should stand in a place outside the hazardous area and be visible at all times by the tractor operator.

After completing the coupling check the safety of the pin hitch.

is completed and the drawbar eye of the second trailer is secured.

- Install the pin and the cotter securing



CAUTION

Only two-axle trailers with a permissible total weight not greater than the parameters of the drawbar and rear hitch of the towing trailer can be aggregated with the trailer.

It is forbidden to connect a second trailer with a permissible total weight greater than the first.

When connecting two trailers to the tractor, both should have the same type of braking system.

the pin.

- Connect the braking, hydraulic and electrical lines according to the instructions in section (4.3).

DISCONNECTING OF THE SECOND TRAILER

- Block the tractor and trailer with parking brake.
- Switch off the tractor engine. Close the tractor cabin and secure it against unauthorized access.
- Disconnect the braking, hydraulic and electrical lines according to the instructions in section (4.3).
- Unlock the coupling bolt on the first trailer. Remove the bolt and drive the tractor away.



DANGER

The trailer with overrun brakes may only be towed individually.

It is forbidden to combine the trailer with the overrun brake in a set of two trailers.

H.3.4.619.03.1.EN

4.4 LOADING

GENERAL LOADING INFORMATION

Before starting loading, make sure that the walls, extensions and the slide window of the chute window are properly closed and secured. The trailer must be placed for straight ahead and connected to the tractor. Loading should take place only when the trailer is placed on level and stable ground. If the trailer is equipped with a tarpaulin, it should be rolled up. If the trailer is equipped with fastening cables for walls and extensions, before loading make

sure that they are in place and the cable release mechanism is set in the correct position and secured with a pin. If the load does not exert pressure on the walls and side extensions, it is allowed to remove the fastening cables. Lack of a fastening rope may damage the load box.

Table 4.1. Approximate volumetric weights of selected loads

Material	Weight kg/m ³
Root Crops:	
raw potatoes	700 - 820
dried potatoes	130 - 150
sugar beets - roots	560 - 720
fodder beets - roots	500 - 700
Organic fertilizers:	
Old manure	700 - 800
Settled down manure	800 - 900
Fresh manure	700 - 750
Compost	950 – 1,100
Dry peat	500 - 600
Mineral fertilizers:	
ammonium sulphate	800 - 850
potassium salt	1,100 – 1,200
super phosphate	850 – 1,440

Material	Weight kg/m ³
basic slag	2,000 – 2,300
potassium sulphate	1,200 – 1,300
kainite	1,050 – 1,440
ground lime fertilizer	1,250 - 1,300
Building Materials:	
cement	1,200 – 1,300
dry sand	1,350 – 1,650
wet sand	1,700 – 2,050
solid bricks	1,500 – 2,100
brick blocks	1,000 – 1,200
stone	1,500 – 2,200
soft wood	300 - 450
hardwood timber	500 - 600
impregnated timber	600 - 800
steel structures	700 – 7,000
ground quicklime	700 - 800
slag	650 - 750
gravel	1,600 – 1,800
Plant litter and roughage:	
dry meadow hay on the swath	10 - 18
hay wilted on the swath	15 - 25
hay in a collecting trailer (dry, wilted)	50 - 80
hay wilted, cut	60 - 70
dry pressed hay	120 - 150
wilted pressed hay	200 - 290
dry stored hay	50 - 90
cut stored hay	90 - 150
clover (alfalfa) wilted on the swath	20 - 25
clover (alfalfa) withered cut on a trailer	110 - 160
clover (alfalfa) wilted on a collecting trailer	60 - 100
dry stored clover	40 - 60

Material	Weight kg/m ³
dry chopped stored clover	80 - 140
dry straw in rollers	8 - 15
wet straw in rollers	15 - 20
wet straw cut on a volume trailer	50 - 80
Dry straw cut on a volume trailer	20 - 40
dry straw cut on a collecting trailer	50 - 90
dry straw cut in a haystack	40 - 100
pressed straw (low compaction)	80 - 90
pressed straw (high compaction)	110 - 150
cereal mass cut on a volume trailer	35 - 75
cereal mass cut on a collecting trailer	60 - 100
forage	28 - 35
forage cut on a volume trailer	150 - 400
forage on a collecting trailer	120 - 270
fresh beet leaves	140 - 160
fresh cut beet leaves	350 - 400
beet leaves on a harvesting trailer	180 - 250
Concentrated feed and compound feed:	
stored chaff	200 - 225
oil cake	880 – 1,000
dried mince	170 - 185
compound feed	450 - 650
mineral mixtures	1,100 – 1,300
oat middlings	380 - 410
wet beet pulp	830-1,000
expeller pressed beet	750 - 800
dry beet pulp	350 - 400
bran	320 - 600
bone meal	700 – 1,000
fodder salt (1)	1,100 – 1,200

Material	Weight kg/m ³
molasses	1,350 – 1,450
silage (underground silo)	650 – 1,050
silage (tower silo)	550 - 750
Seeds:	
broad bean	750 - 850
mustard	600 - 700
pea	650 - 750
lentil	750 - 860
bean	780 - 870
barley	600 - 750
Shamrock	700 - 800
grass	360 - 500
maize	700 - 850
wheat	720 - 830
rape	600 - 750
flax	640 - 750
lupine	700 - 800
oat	400 - 530
Lucerne	760 - 800
rye	640 - 760
Other:	
dry soil	1,300 – 1,400
wet soil	1,900 – 2,100
fresh peat	700 - 850
compost soil	250 - 350
<i>Source: „Technologia prac maszynowych w rolnictwie”, PWN, Warsaw 1985</i>	

Regardless of the type of transported load, the user is obliged to secure it in such a way that the load cannot move freely in the load box or cause road pollution. If this

is not possible, it is prohibited to transport this type of load.

Materials that come into contact with painted or steel surfaces may cause

**CAUTION**

The trailer is intended for the transport of crops and agricultural products (bulky or loose). It is allowed to transport other loads (wood, building materials, packed loads), provided that the load box is protected against damage (abrasion of the paint coating, corrosion, etc.). The load should be evenly distributed in the load box.

Uneven distribution of the load may cause overloading of the trailer's chassis.

It is forbidden to exceed the permissible load capacity of the trailer because it threatens road safety and may cause damage to the machine.

Loading should be performed by a person with appropriate authorization to operate the equipment (if required).

**DANGER**

The trailer load must be secured to prevent it from shifting and polluting the road when travelling. If it is not possible to properly secure the load, it is forbidden to transport such materials.

Trailer overloading, inefficient loading and securing of loads are the most common causes of accidents during transport.

It is forbidden to transport people and animals.

damage, should be transported in sealed packaging (bags, boxes, barrels, etc.), and after transporting the load box should be thoroughly washed with a strong water jet.

If materials that exert point pressure on the floor of the load box are transported, they should be protected against damage by placing thick boards, plywood or other materials with similar properties under the load.

Due different density of materials, the

use of the total capacity of the load box may exceed the allowable capacity of the trailer. Approximate specific weight of selected materials is presented in table (4.1). Therefore, pay special attention not to overload the trailer.

When loading goods on Euro-pallets and box-pallets, pay attention to how they are arranged on the platform. The pallets must be secured so that they cannot move freely on the platform. Laying pallets in layers is prohibited.

BULK LOADS

Loading of loose materials is usually carried out with the help of loaders or conveyors, possibly by manual loading. Loose materials must not protrude beyond the outline of walls or extensions. After loading, the load layer should be evenly distributed over the entire surface of the load box. If the trailer is equipped with wall connecting cables and extensions during loading loose materials, they should be connected with a connecting cable. Secure the cable

**DANGER**

If it is necessary to transport permitted hazardous materials, please read the regulations for the transport of hazardous materials in force in your country and the ADR agreement in detail.

Familiarize yourself with the contents of the manufacturer's information leaflets, adhere to the transport and handling instructions. Make sure that additional personal protective equipment (masks, rubber gloves, etc.) is necessary during loading work.

release mechanism with a cotter pin.

Rapeseed, seeds of other plants with very small grains or powdered materials can be transported provided that the load box is thoroughly sealed, in places where the connection gap is smaller than the grain diameter. For sealing, it is recommended to use profiled rubber gaskets, silicone sealants, foil, cord or textile materials used for tarpaulins.

In addition, it is necessary to secure the load with a tarpaulin. It will protect the load against scattering while travelling, blowing away by the wind and will additionally protect the load against moisture. This is especially dangerous in the case of loose materials. They can significantly absorb water, which can increase the weight of the load while driving. In extreme cases, the total weight of the trailer may exceed the permissible total weight of the vehicle. Some loose loads (e.g. building materials such as gravel, slag) can cause faster damage to the paint coating.

PIECE OR LUMP LOADS

Piece or lump loads are usually hard materials of much larger sizes than loose loads (stones, coal, bricks, aggregate). These materials without prior preparation of the load box may cause dents on the floor or walls and abrasion of the paint coating. For this reason, it is necessary to



DANGER

If there is a danger of the load moving in packaging, it is forbidden to transport this type of material. The shifting load is a serious danger when driving the tractor operator and other road users.

cover the floor and possibly the walls and add a thick plywood, hard vortex plate, thick boards or other materials with similar properties. The user acting contrary to the above recommendations may void the warranty. Loading piece or lump materials must be from a low height. The load cannot fall with great force on the floor of the load box despite its protection.

DANGEROUS GOODS

Pursuant to the European ADR agreement regarding the international carriage of dangerous goods by road, this type of cargo (specified in detail in this agreement) is prohibited using agricultural trailers. The only exceptions are plant protection products and artificial fertilizers that can be transported with an agricultural trailer, provided that they are transported in appropriate packaging and in the quantities provided for in the ADR agreement.

BULK LOADS

Bulk loads (light, high-volume), such as hay, pressed cubes or bales, straw, fodder, etc., it is recommended to load with the help of appropriate accessories: bale grippers, forks, etc. The load can be loaded

even above the load box extensions with special attention due to the stability of the trailer and proper fastening and securing of the load. It should be remembered that a highly placed load adversely affects the stability of the trailer.

LOADS IN PACKAGING

Loads transported in packages (boxes, sacks) should be placed tightly next to each other starting from the front wall. If it is necessary to lay several layers, individual batches should be applied alternately (in a block system). The load must be laid tightly and over the entire surface of the trailer floor. Otherwise, the load will shift during the journey. Due to the construction of the trailer (adapting the load box to transport crops and agricultural products, no load fastening points), packed materials can be placed only below the contour of the walls or extensions of the load box. If the trailer is equipped with mesh extensions, the height of the load layer may not be higher than 600 mm, i.e.

it may not exceed the upper edge of the walls. A higher layer of load may shift while driving and cause significant damage to the mesh extensions and the scattering of the load.

Materials that can cause steel corrosion, chemical damage or react in a different way by adversely affecting the construction materials of the trailer may be transported only if the load is properly prepared. Materials must be tightly packed (in plastic bags, plastic containers, etc.). During transport, the contents of the packages must not get into the load box, so ensure that the containers are properly sealed.

Due to the variety of materials, tools, methods of securing and securing loads, it is not possible to describe all methods of loading. When working, be guided by reason and your own experience. The trailer user is obliged to read the regulations regarding road transport and comply with their recommendations.

H.3.3.259.05.1.EN

4.5 LOAD TRANSPORTATION

When driving on roads (public and non-public), comply with traffic regulations, be prudent and considerate. Below are the most important guidelines for driving a tractor with a trailer or trailers attached.

- Before moving off make sure that there are no bystanders, especially children, near the trailer and tractor. Ensure proper visibility.
- Make sure that the trailer is correctly connected to the tractor and tractor's hitch is properly secured.
- The trailer must not be overloaded, the load must be distributed evenly in such a way that it does not exceed the permissible pressure on the trailer's running gear. Exceeding the permissible load capacity of the vehicle is forbidden and may cause damage to the machine, and may also pose a threat during road travel for the tractor and trailer operator or other road users.
- The permissible design speed and speed resulting from restrictions on road traffic regulations must not be exceeded. The travel speed should be adjusted to the prevailing road conditions, trailer load condition, type of load carried and other conditions.



CAUTION

Before driving the trailer, check that:

- bolts connecting the load box to the lower frame are secured against spontaneous falling out,
- extensions pins are secured against falling out.

Travelling with a volumetric load through ruts, ditches, slopes etc. poses a great risk of tipping over. Take special care.

- The trailer may be towed on slopes of up to 8°, unloading should only be carried out on level ground.
- The trailer disconnected from the tractor must be secured by immobilizing it with the parking brake and placing chocks or other elements without sharp edges under the wheel. Leaving an unsecured trailer is prohibited. In the event of a machine breakdown, stop at the side of the road without endangering other road users and mark the stopping place in accordance with traffic regulations.
- Before driving, the trailer's braking force should be adjusted by setting the braking force regulator lever - figure (4.7) - for pneumatic braking systems,
- When travelling on public roads, the trailer must be marked with a slow-moving vehicle warning sign located

on the rear wall of the load box, if the trailer is the last vehicle in the set.

- The tractor operator is required to equip the trailer with an approved or approved warning reflective triangle.
- While driving, obey the rules of the road, signal the change of direction by means of direction indicators, keep clean and take care of the technical condition of the lighting and signalling installation. Damaged or lost lighting and signalling components must be repaired or replaced immediately.
- Avoid ruts, depressions, ditches, or driving along roadside slopes. Driving across such obstacles can cause the trailer and tractor to tilt suddenly. This is particularly important because the centre of gravity of the trailer with load (and especially with volumetric load) adversely affects driving safety. Driving near the edges of ditches or canals is dangerous due to the risk of landslides under the wheels of a trailer or tractor.

- The travel speed should be reduced sufficiently in advance of driving to curves, when driving on uneven or sloping terrain.
- When driving, avoid sharp turns, especially on slopes.
- It should be remembered that the braking distance of the set increases significantly with the increase in the weight of the transported load and the increase in speed.
- Control the behaviour of the trailer when driving on uneven terrain and adjust the speed to terrain and road conditions.
- The trailer is adapted for driving on slopes up to a maximum of 8°. Moving the trailer over slopes may cause the trailer to overturn as a result of loss of stability. Prolonged driving on sloping ground creates a risk of loss of braking efficiency.

H.3.3.619.06.1.EN

4.6 UNLOADING

The trailer is equipped with a hydraulic tipping system, and a suitable frame and load box construction enabling tipping to the sides and to the rear. Tipping the load box is controlled by means of the distributor of the tractor's external hydraulic system.

The trailer is unloaded in the following order:

- the tractor and trailer should be placed for straight driving on level, hard and level ground,
- Block the tractor and trailer with parking brake,
- tipping pins (1), (2) (connecting the load box to the lower frame) should be placed on the side on which the unloading will be carried out and properly secured - figure (4.8).
- tipping pins and individual seats are designed in such a way that they cannot be moved diagonally across the load box, which would cause damage to the trailer,
- open appropriate wall closures and / or extensions, or open the chute slide in the rear wall (depending on the intended direction and method of unloading),

Use caution when opening, as

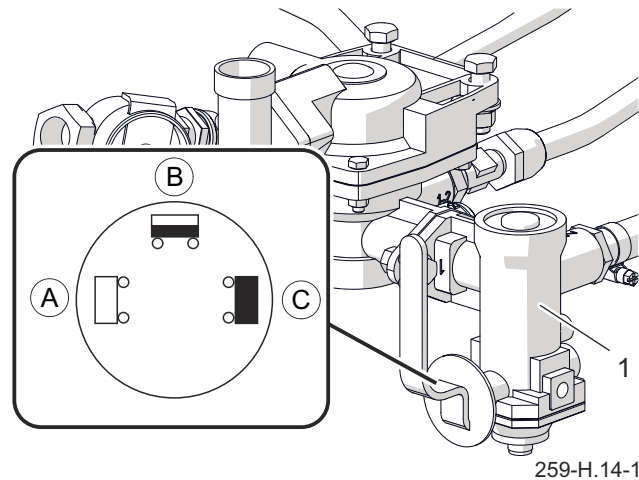

Figure 4.7 Braking force regulator

(1) regulator

(A) 'UNLOADED' position

(B) 'HALF LOAD' position

(C) 'FULL LOAD' position

the load can put a lot of pressure on the walls.

When opening wall closures do not stand in the area of the wall to be opened and the load being unloaded

- set the three-way valve lever (2) - figure (3.9) controlling operation of the hydraulic tipping system circuits to position "1" - tipping the first trailer, *In case when a second trailer is connected, its unloading should be made only when the first trailer load box has been lowered and the three-way valve controlling the hydraulic tipping system - set in the "2" position of*

- the second trailer tipping),
- using the divider lever in the driver's cab cause the load box to tilt,
 - after unloading, lower the load box, clean the edges of the floor and walls,
 - close and secure walls, extensions and a chute window,
 - before moving off make sure that the tipping pins are secured in their seats.

H.3.3.259.07.1.EN

4.7 CHUTE GATE SERVICE

CAUTION

In the event of tipping backwards, insert and secure the bolts in the rear sockets of the crate (II + III). In case of tipping to the right side, insert and secure the pins in the right crate seats (III + IV), while in the case of tipping to the left side, insert the pins in the left crates (II + I).

The tipping pin inserted and properly secured is shown in figure (4.8): Handle down, pins hidden in the socket.

ADVICE

Drawings describing the construction of the trailer show an example equipment configuration. Detailed information on all options can be found in the *Equipment* chapter.

The rear wall of the load box is standard equipped with a chute slide (1) - figure

(4.5) and additionally can be equipped with a chute (2) for unloading loose materials. As an optional equipment, the rear wall can be made in a version with two or three chutes.

The chute design enables accurate dosing

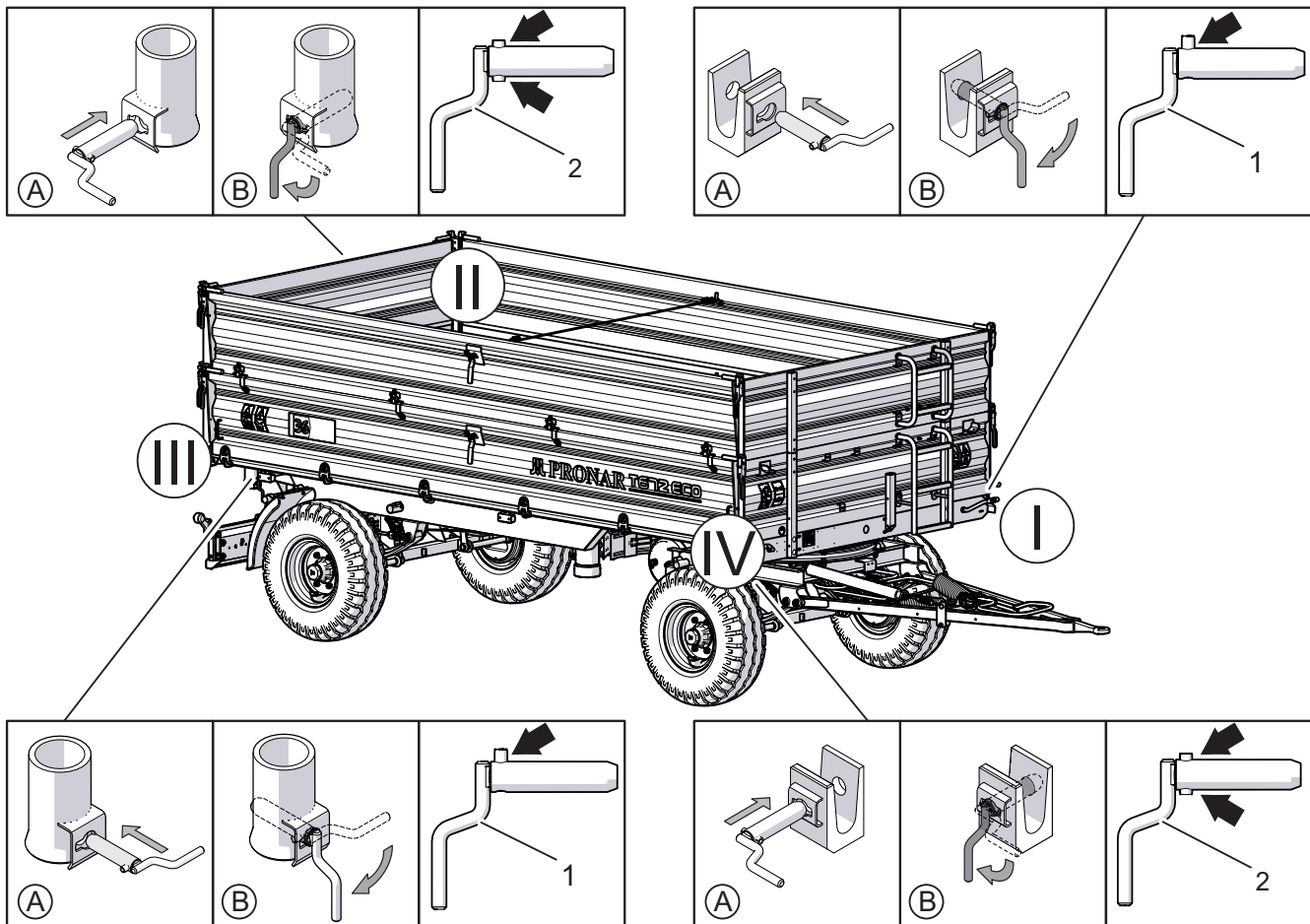

619-H.07-1

Figure 4.8 Locking of the tipping pins
 (1) tipping pin I (left front or right rear), (2) tipping pin II (right front or left rear),

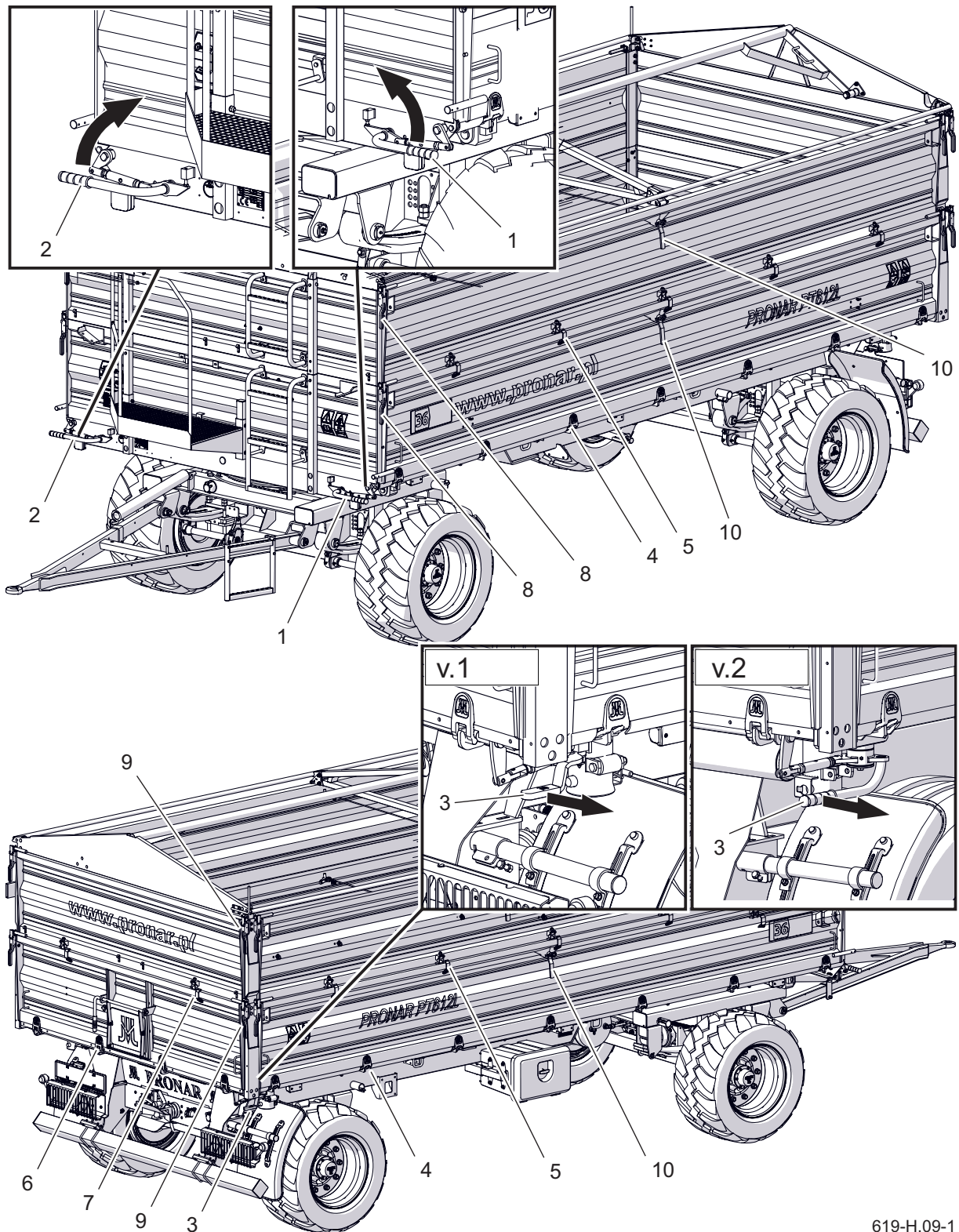

619-H.09-1

Figure 4.9 Location of hinges and wall locks and extensions in the trailer
 (1) lever for closing the left wall, (2) lever for closing the right wall, (3) lever for closing the rear wall,
 (4) lower hinges for the side wall, (5) upper hinges for the side wall, (6) lower hinges for the rear wall,
 (7) upper hinges of the rear wall, (8) lock of the wall and side extension, (9) lock of the wall and rear
 extension, (10) lever for locking the cable connecting the bottom walls and extensions

**DANGER**

When opening wall closures and locks, be extremely cautious due to pressing the load on the walls. When closing walls and the chute window slide, be extremely careful to avoid crushing your fingers.

of the load into the packaging (bags, boxes, etc.). The size of the gap opening should be determined by the lever (3). To do this, loosen the bolt locking the slide (4), open the slide at the selected height and secure it again with the screw.

During unloading, using the chute, the wall locks and extensions must not be opened, and the load box must be lifted slowly and smoothly. Rapid lifting of the load box will cause very high pressure on the rear part of the load box as a result of the load shifting and may threaten the stability of the machine.

**CAUTION**

Unloading of the trailer can only be carried out when the machine is placed on level, hard and level surface and connected to the tractor. Tractor and trailer must be placed for straight-ahead driving.

Use only original tipping pins. The use of non-original pins may damage the trailer. Tipping pins must be properly locked.

The length of the cable controlling the valve limiting the angle of inclination of the load box is set by the Manufacturer and it is forbidden to adjust it by the User.

It is forbidden to pull the trailer forward if the bulk or scattering load has not been unloaded.

Unloading of volumetric materials that have been loaded above 1 meter can only be done by tilting the load box backwards.

Make sure that during unloading nobody is near the tilted load box and the falling load.

Tilting of the load box may be performed only when the trailer is connected to the tractor.

It is forbidden to tilt the load box during strong gusts of wind.

It is forbidden to start or drive with the load box raised.

If the trailer is equipped with central extensions, unloading can only be done by tipping the load box backwards.

H.3.3.259.08.1.EN

4.8 OPERATION OF THE WALL EXTRACTOR MECHANISM

The extraction mechanism is an additional accessory of the trailer. Individual elements are mounted to the front wall and side walls. The extraction mechanism is intended to assist in closing or opening the side walls.

OPENING OF THE SIDE WALLS (DOWN)

- Make sure the bottom wall bolts are properly closed and locked.
- Open the upper locks (6) and remove the safety pins from the lugs securing the upper extension to the side wall.

- Open the side wall. Take special care.

OPENING OF THE SIDE WALLS (UP)

- Make sure that the upper locks (6) and the corresponding eyes for fastening the walls and extensions are closed and secured.
- Remove the cotter pin (4), remove the washers (3).
- Remove the lug (2) of the extraction mechanism from the wall bolt.
- Reinstall the washers and cotter pin on the wall bolt.

H.3.3.259.09.1.EN

4.9 TARPAULIN SERVICE

To protect the load against spilling and to protect against adverse weather conditions, the trailer can be equipped with a tarpaulin and mounting frame.

TARPAULIN UNROLLING

- Access the balcony (11) using the ladder located on the front wall.
- Place the frame ridge pipe (1) in the middle of the load box.
- Unwind the tarpaulin (2) by turning the crank on the roller beam (5).

Unwind slowly, which will allow you to evenly spread the tarpaulin.

- Fasten the cables (2) to the hooks (7) on the front wall and then to the rear wall of the load box.
- Fasten the seat belts (4) and stretch the tarpaulin using the tensioner.

Incorrect stretching of the tarpaulin causes water to accumulate on its surface, etc. As a consequence, the tarpaulin may be deformed and fail to fulfil its purpose.

TARPAULIN FOLDING

- Loosen the belt tensioners and remove the belts (4) fastening the



DANGER

When closing the chute slide, be extremely careful to avoid crushing your fingers.

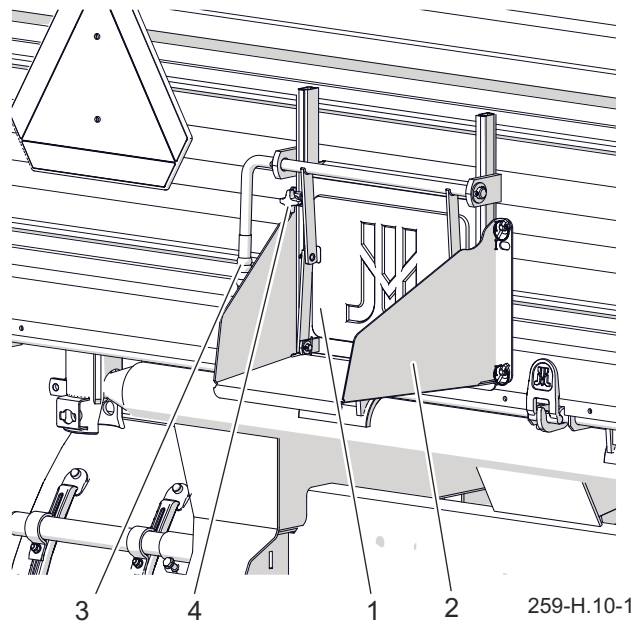

Figure 4.10 Chute gate valve
(1) chute slide, (2) chute, (3) lever,
(4) locking screw

tarpaulin.

- Loosen the belt tensioners and remove the belts (4) fastening the tarpaulin.
- Roll up the tarpaulin by turning the crank on the roller beam (5) so that it rests on the stops (6).
- After rolling the tarpaulin, set the crank so that the crank handle does not protrude beyond the side walls of the box.

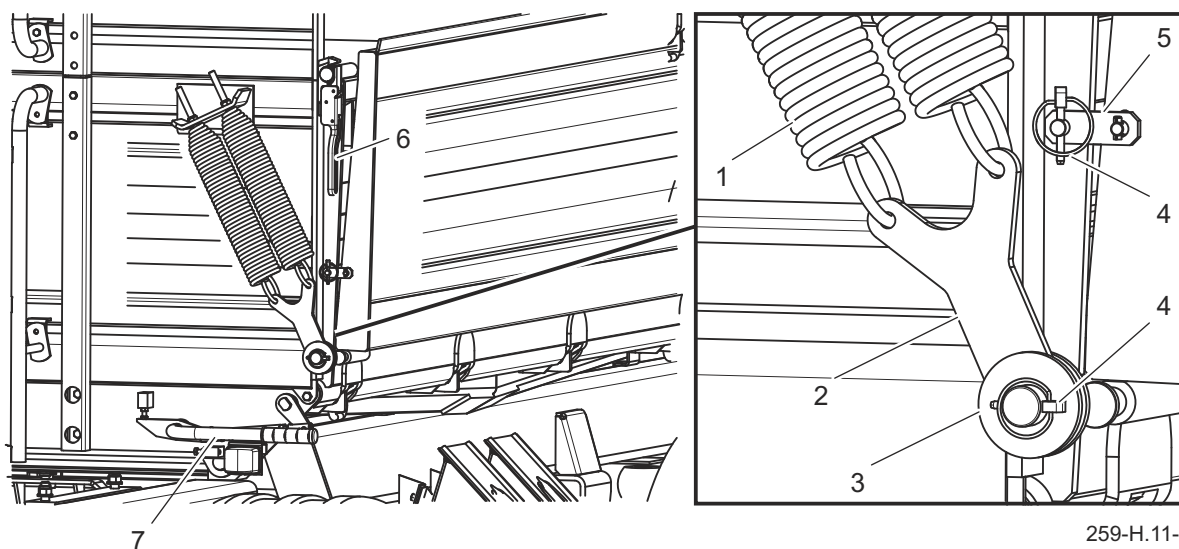

Figure 4.11 Extraction mechanism

(1) spring, (2) eye, (3) washer, (4) cotter pin, (5) lower closing lever, (6) upper closing lever

H.3.3.259.10.1.EN

4.10 RULES FOR USE OF TIRES

- When working with tires, the machine should be secured against rolling by placing chocks under the wheels.

The wheel can be dismantled only when the trailer is not loaded.

- Repair work on wheels or tires should

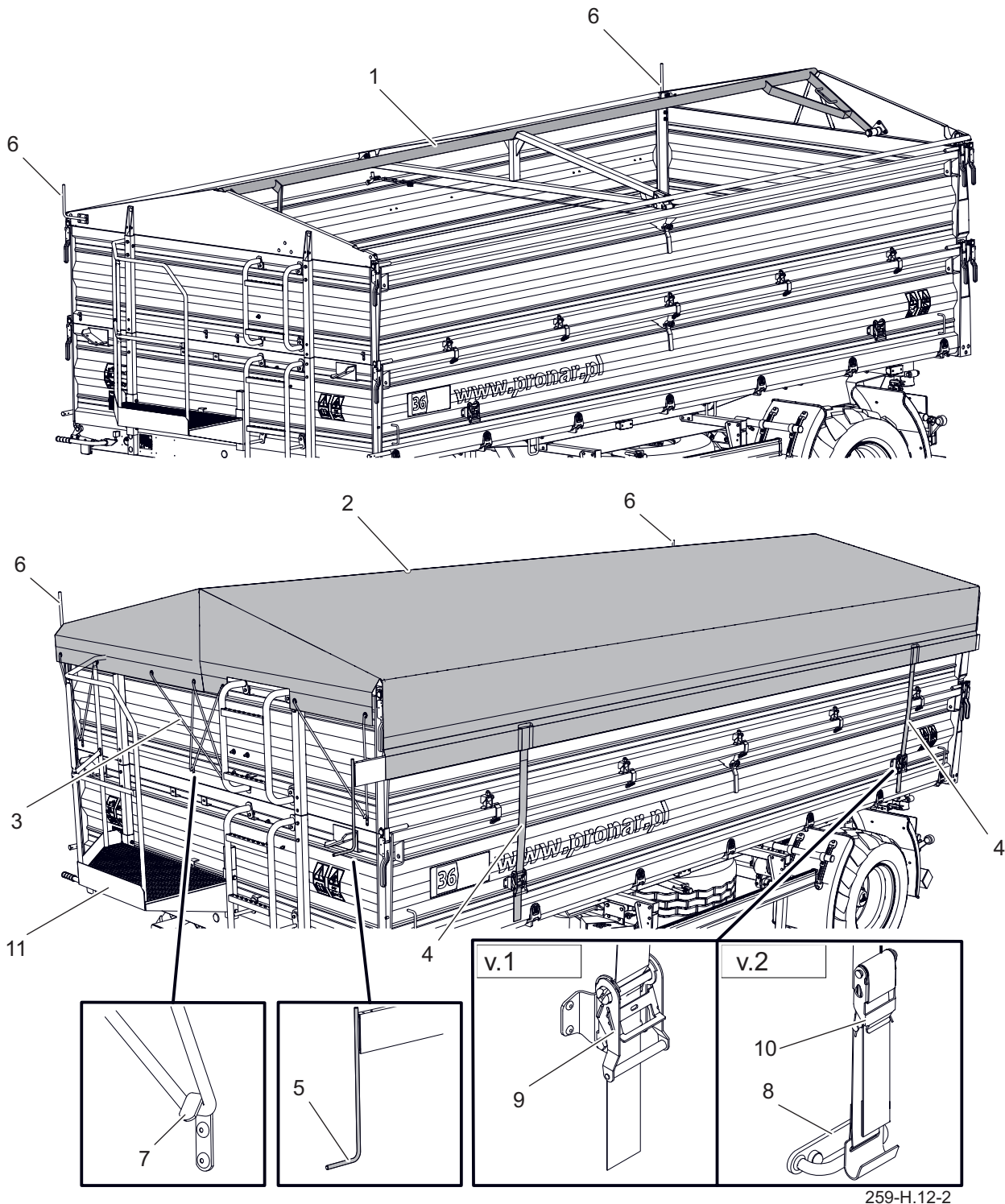

Figure 4.12 Tarpaulin service

(1) frame ridge pipe, (2) tarpaulin, (3) cable (expander), (4) tarpaulin belt, (5) roller beam crank, (6) tarpaulin stop, (7) cable hook, (8) belt hook, (9) tensioner, (10) belt tensioner, (11) balcony

be carried out by persons trained and authorized to do so. These works should be carried out using appropriately selected tools.

- Checking the tightening of the wheel nuts should be carried out after the first use of the trailer, every 2-3 hours during the first month of using the machine and then every 30 hours of driving. Each time, repeat all operations if the wheel was disassembled. Wheel nuts should be tightened in accordance with the recommendations contained in the MAINTENANCE chapter.
- Regularly check and maintain proper tire pressure as recommended in the instructions (especially after a long break of not using the trailer).
- Tire pressure should also be checked during all-day intensive work. It should be taken into account that an increase in tire temperature can increase the pressure by up to 1 bar. With such a rise in temperature and

**CAUTION**

Rolling and unrolling of the tarpaulin should be done standing on the balcony.

When driving with the tarpaulin rolled out, it is not allowed to carry a load that protrudes beyond the wall contour.

The tarpaulin can accumulate water or snow, which excessive amount can damage the tarpaulin and its frame. Therefore, this type of accumulated material should be removed immediately.

pressure, reduce the load or speed.

- Never reduce pressure by venting if it increases due to temperature.
- Valves must be secured with appropriate caps to avoid soiling.
- Do not exceed the maximum trailer speed.
- During the whole day cycle, take a minimum of one hour break at noon.
- Observe 30 minutes breaks for cooling the tires after driving 75 km or after 150 minutes of continuous driving, whichever comes first.
- Avoid damaged surfaces, sudden and variable manoeuvres, and high speeds when turning.

H.3.4.622.10.1.EN

4.11 CLEANING OF THE TRAILER

The trailer should be cleaned depending on demand and before a longer standstill (e.g. before winter). The use of a pressure washer obliges the user to become familiar with the principle of operation and recommendations for the safe operation of this device.

GUIDELINES FOR CLEANING THE TRAILER

- Clean and wash the trailer with a strong stream of water and allow to dry in a dry and ventilated place.
- To clean the trailer, use only clean running water or water with a cleaning detergent additive with a neutral pH.
- The use of pressure washers increases the effectiveness of washing, but be careful when working. During washing, the nozzle of the cleaning aggregate must not be closer than 50 cm from the surface being cleaned.
- The water temperature should not exceed 55 °C.
- Do not direct the water jet directly at the elements of the installation and equipment of the trailer, i.e. control valve, braking force regulator, brake cylinders, hydraulic cylinders, pneumatic, electric and hydraulic plugs, lights, electrical connectors, information and warning stickers, rating plate, cable connectors, points lubricating trailers, etc. High pressure water jet may cause mechanical damage to these components.
- For cleaning and maintenance of plastic surfaces, it is recommended to use clean water or specialized preparations intended for this purpose.
- Do not use organic solvents, preparations of unknown origin or other substances that may damage the lacquered, rubber or plastic surface. It is recommended to make a test on an invisible surface in case of doubt.
- Surfaces oily or greasy should be cleaned with petrol or degreasing agents, and then washed with clean water and detergent. Follow the cleaning agent manufacturer's instructions.
- Detergents intended for washing should be stored in their original containers, or alternatively, but marked exactly. The preparations cannot be stored in containers intended for storing food and beverages.
- Keep the hoses and gaskets clean. The materials from which these elements are made may be susceptible

to organic substances and some detergents. As a result of long-term effects of various substances, the aging process is accelerated and the risk of damage increases. Elements made of rubber are recommended to be maintained with the help of specialized preparations after thorough washing.

- Observe environmental protection principles, wash trailer in designated places.

**CAUTION**

During work, use appropriate, close-fitting protective clothing, gloves and the right tools.

- Washing and drying the trailer must take place at temperatures above 0 °C.

**DANGER**

Refer to the instructions for using cleaning detergents and preservatives.
When washing with detergents, wear suitable protective clothing and eye protection.

In winter, frozen water can cause damage to the paint coat or machine components.

- After washing, wait for the trailer to dry and then grease all control points as recommended. Wipe off excess grease or oil with a dry cloth.

H.3.3.259.13.1.EN

4.12 STORAGE

- It is recommended that the trailer be stored indoors or under a roof.
- If the machine will not be used for a long period of time, it must be protected against the effects of weather conditions, especially those that cause corrosion of steel and accelerate the aging of tires. During this time the machine must be unloaded. The trailer should be thoroughly washed and dried.
- Corroded areas should be cleaned of rust, degreased and protected with a primer paint, and then painted with a topcoat according to the colour scheme.
- In the event of a longer stop, it is necessary to lubricate all components regardless of the period of the last treatment.
- Rims and tires should be carefully washed and dried. During longer storage of the unused trailer, it is recommended to move the machine once every 2-3 weeks so that the place of contact of the tire with the ground is in a different position. The tires will not deform and will maintain proper geometry. You should also check your tire pressure from time to time, and if necessary inflate the wheels to the correct value.
- If the trailer is equipped with a tarpaulin, it should be thoroughly washed and dried. If it is possible, it is recommended to store a clean tarpaulin hanging, otherwise it should be rolled up carefully without causing creases and kinks in the material.
- The tarpaulin can accumulate water or snow, which excessive amount can damage the tarpaulin and its frame. Therefore, this type of accumulated material should be removed immediately

H.3.3.259.14.1.EN

CHAPTER 5

PERIODIC INSPECTIONS OF THE TRAILER

5.1 GENERAL

When using the trailer, it is necessary to constantly check the technical condition and perform maintenance procedures that will allow the machine to be kept in good technical condition. Therefore, the machine user is obliged to perform all maintenance, control and adjustment activities specified by the Manufacturer in accordance with the assumed schedule. Repair of the during the warranty period may only be carried out by Authorized Sales and Service Points (APSiO).

In the event of unauthorized repairs, changes to factory settings or activities that have not been considered as being possible by the Cause operator (not described in this manual), the user loses the warranty.



DANGER

It is forbidden to use a damaged trial. The trailer may only be towed when the braking system, the drawbar and the running gear are in working order. Repairs during the warranty period may only be carried out by authorized service centres.

The trailer's warranty inspection is only carried out by authorized service centres. After the warranty expires, it is recommended that inspections be carried out by specialized repair workshops.



CAUTION

Before carrying out technical service or maintenance on the trailer, lower the load box. If it is necessary to raise the load box, turn it over to the side and secure it against falling down using the load box support. The load box cannot be loaded. The trailer must be connected to the tractor and secured with wedges and blocked with the parking brake.

I.3.4.622.01.1.EN

5.2 PERIODIC INSPECTION SCHEDULE

Table 5.1. Review categories

Category	Description	Responsible	Frequency
A	Every day review	Operator	Every day before first start-up or every 10 hours of continuous shift work.
B	Maintenance	Operator	The inspection is carried out periodically every 1000 kilometres travelled or every month the trailer works, whichever comes first. Each time before performing this review, a daily check must be carried out.
C	Maintenance	Operator	Inspection carried out periodically every 3 months. Each time before carrying out this inspection, carry out a daily inspection and inspection every one month of use of the trailer.
D	Maintenance	Operator	Inspection carried out periodically every 6 months. Each time before carrying out this inspection, perform a daily inspection, inspection every 1 month of the trailer use and inspection every 3 months.
E	Maintenance	Operator	Inspection carried out periodically every 12 months. Each time before carrying out this inspection, perform a daily inspection, inspection every 1 month of the trailer use and inspection every 3 months.
F	Maintenance	Service ⁽¹⁾	Inspection carried out every 4 years of trailer use

(1) - post-warranty service

Table 5.2. Periodic inspection schedule

Description of activities	A	B	C	D	E	F	Page
Checking the air pressure in the wheels	•						5.7
Tank drainage	•						5.8
Checking plugs and connection sockets	•						5.9
Covers inspection	•						5.10
Checking the trailer before driving off	•						5.11
Measurement of air pressure, check tires and wheels		•					5.12
Cleaning the air filters			•				5.13
Checking brake lining wear				•			5.14
Checking the clearance of the axle bearings				•			5.15
Checking of mechanical brakes				•			5.16
Cleaning the drainage valve				•			5.17
Checking of parking brake cable tension					•		5.18
Hydraulic system inspection					•		5.20
Control of pneumatic system					•		5.21
Screw connections inspection	See chapter: <i>Screw connections inspection</i>						5.22
Lubrication	See table: <i>Trailer lubrication schedule</i>						5.24
Replacement of hydraulic hoses						•	5.30

Table 5.3. Control parameters and settings

Description	Value	Notes
Hook height		
Braking system		
Piston rod stroke in pneumatic systems	25 - 45 mm	
Piston rod stroke in hydraulic systems	25 - 45 mm	
Minimum brake lining thickness	5 mm	
Angle between the trailer axis and the fork	90°	With the brake de-pressed
Parking brake		
Permitted parking brake cable clearance	20 mm	

I.3.3.259.02.1.EN

5.3 PREPARATION OF THE TRAILER



DANGER

Secure the tractor cab against unauthorized access. When working with the jack, the user must read the instructions for this device and follow the manufacturer's instructions. The jack must stand firmly against the ground and the trailer elements. Before starting maintenance and repair work with the trailer lifted, make sure that the trailer is properly secured and will not roll during operation.

- Hitch trailer to tractor.
- Place the tractor and trailer on firm and level ground. Position the tractor for straight-ahead travel
- Apply the tractor parking brake.
- Turn off the tractor engine and remove the keys from the ignition. Close the tractor cabin, thus protecting the tractor against unauthorized access.
- Place safety wedges under the trailer wheel.

Ensure that the trailer will not roll during inspection.

- In case when the wheel needs to be raised during the inspection, place

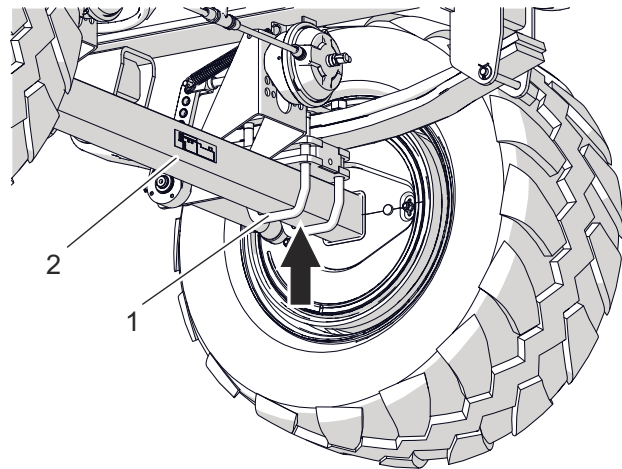

259-I.01-1

Figure 5.1 Hoist support point

(1) axle fixing pin (2) road axle

the locking wedges under the wheel on the opposite side. Place the jack in places marked with an arrow.

The jack must rest on a firm and stable surface.

- The jack must be suited to the trailer weight.
- In exceptional cases, release the trailer parking brake, e.g. when measuring the play of the axle shaft bearings. Take special care.

I.3.3.259.03.1.EN

5.4 CHECKING THE AIR PRESSURE IN THE WHEELS

- Visually assess the degree of inflation of the road wheels.
- If necessary, check the air pressure with a pressure gauge and inflate the wheel to the required pressure.

The required air pressure is described on a sticker (1) on the rim.

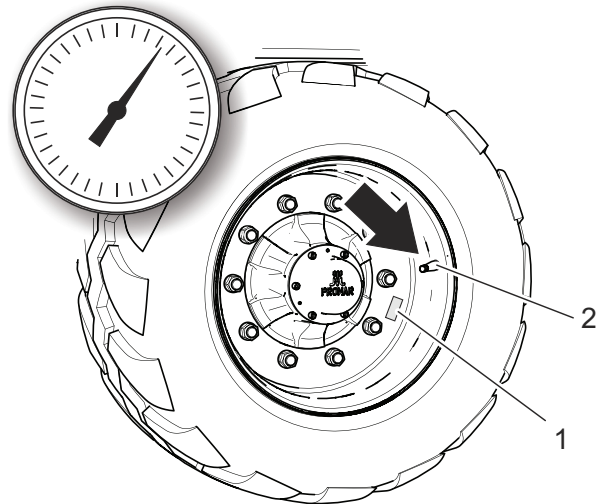

Figure 5.2 Trailer wheel

(1) sticker (2) valve



CAUTION

Using the trailer in which tires are not properly inflated may lead to permanent damage to the tire as a result of delamination of the material. Incorrect tire pressure also causes faster tire wear.

ADVICE

The tire pressure value is on the information sticker on the wheel rim.

I.3.3.259.04.1.EN

5.5 TANK DRAINAGE

- Press the stem of the drain valve (1) located at the bottom of the tank (2).

The compressed air in the tank will remove water outside.

- After releasing the stem, the valve should close automatically and stop the outflow of air from the tank.
- If the valve stem does not want to return to its position, wait until the tank empties. Then unscrew and clean or replace the valve with a new one.

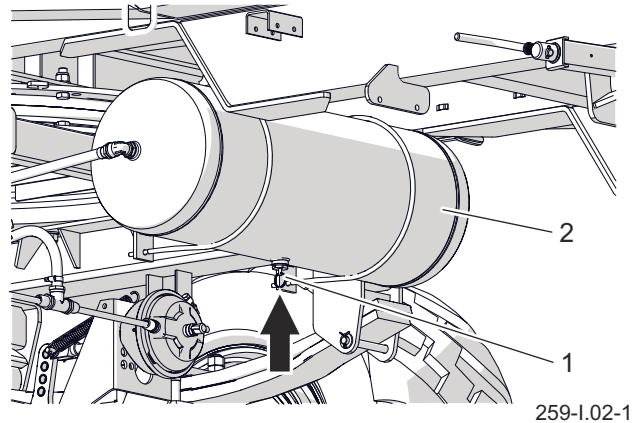

Figure 5.3 Air tank
(1) drain valve (2) air tank

I.3.4.622.05.1.EN

5.6 CHECKING PLUGS AND CONNECTION SOCKETS

A damaged connector body or socket for connecting a second trailer qualifies them for replacement. In the event of damage to the cover or gasket, replace these elements with new, functional ones. Contact of pneumatic connection seals with oils, grease, gasoline etc. may damage them and accelerate the aging process.

If the trailer is disconnected from the tractor, connections should be protected with covers or placed in their designated sockets. Before the winter period, it is recommended to preserve the seal with preparations intended for this purpose (e.g. silicone lubricants for rubber elements).

Each time before connecting the machine, check the technical condition and degree of cleanliness of connections and sockets on the agricultural tractor. If necessary clean or repair tractor sockets.

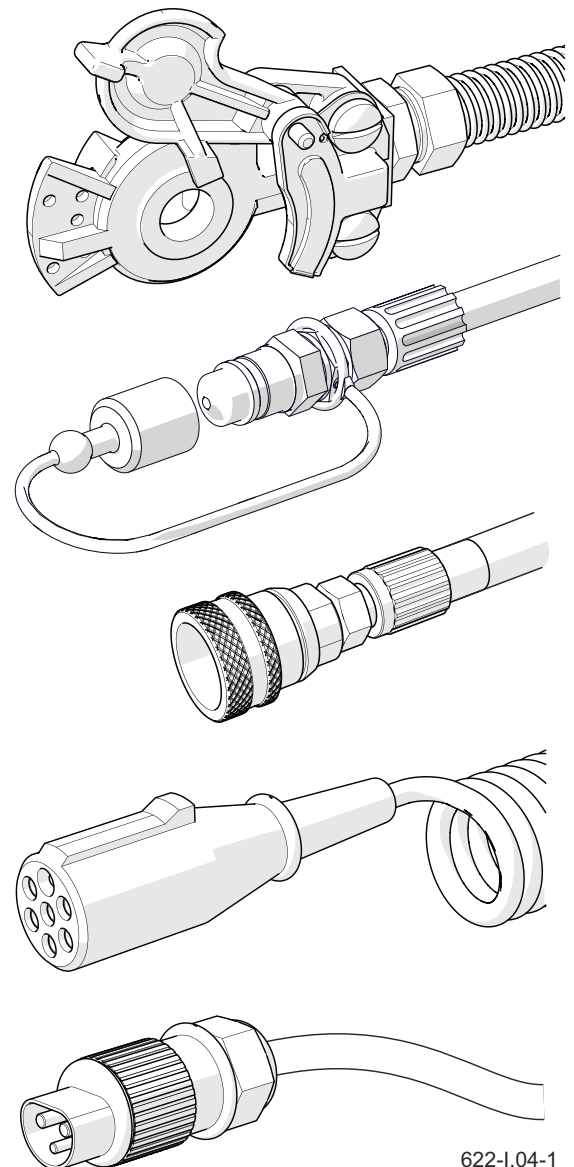

622-I.04-1

Figure 5.4 Checking the trailer connections

I.3.4.622.06.1.EN

5.7 CHECKING THE TRAILER BEFORE DRIVING OFF

- Before connecting trailer to the tractor make sure that the hydraulic and pneumatic conduits are not damaged.
- Check the completeness, technical condition and correct functioning of the trailer lighting.
- Check the cleanliness of all electric lamps and reflectors.
- Before travelling on a public road, remove the rear lamp covers and place them in the designated place.
- Check the correct mounting of the triangular plate holder for slow moving vehicles and the plate itself.
- Make sure that the tractor has a reflective warning triangle.
- Check that the actuator ventilation openings are not clogged with dirt and that there is no water or ice inside. Check the correct mounting of the actuator.

Clean the actuator if necessary.

In winter, it may be necessary to defrost the actuator and remove accumulated water through unclogged ventilation holes. If any damage is found, replace the



DANGER

Driving with defective lighting installations braking is prohibited.
If the trailer is damaged, it be discontinued until it is repaired.

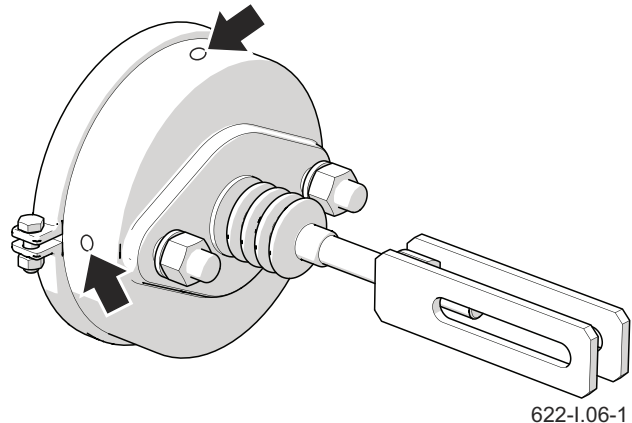

Figure 5.5 Brake cylinder

actuator. When mounting the actuator, keep its original position relative to the bracket.

- When moving off check the operation of the service brake system. For proper operation of the pneumatic system, an appropriate level of air pressure in the trailer air tank is required.
- Check the correct operation of the other systems while operating the trailer.

I.3.4.622.08.1.EN

5.8 MEASUREMENT OF AIR PRESSURE, CHECK TIRES AND WHEELS

During pressure measurement the trailer must be unloaded. Checking should be carried out before driving, when the tires are not warm, or after a long standstill of the trailer.

THE SCOPE OF ACTIVITIES

- Connect a pressure gauge to the valve.
- Check air pressure.
- If necessary, inflate the wheel to the required pressure.

The required air pressure is described on a sticker (1) on the rim.

- Check tread depth.
- Check the side wall of the tire.
- Inspect the tire for defects, cuts, deformations, bumps indicating mechanical damage to the tire.
- Check that the tire is correctly positioned on the rim.
- Check tire age.

When checking pressure, pay attention to the technical condition of rims and tires. In the event of mechanical damage, consult your nearest tire service centre and

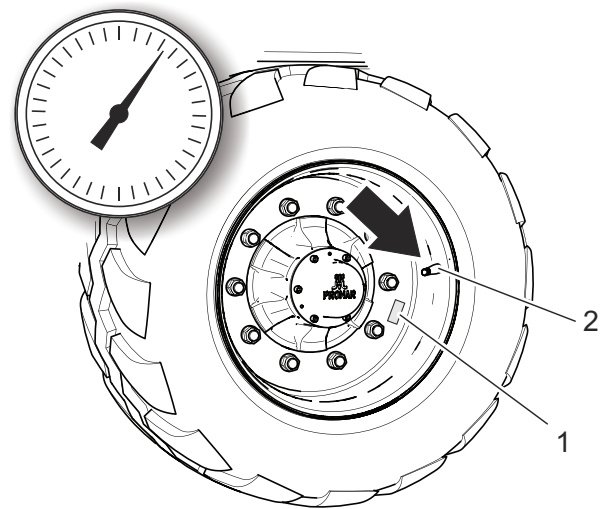

624-I.02-1

Figure 5.6 Trailer wheel
(1) sticker (2) valve

ensure that your tire defect is eligible for replacement. Rims should be checked for deformation, material cracks, weld cracks, corrosion, especially around welds and in the place contact with the tire.

ADVICE

In the event of intensive use of the trailer, we recommend more frequent pressure checks



CAUTION

Using the trailer in which tires are not properly inflated may lead to permanent damage to the tire as a result of delamination of the material. Incorrect tire pressure also causes faster tire wear.

I.3.4.622.09.1.EN

5.9 CLEANING THE AIR FILTERS

THE SCOPE OF ACTIVITIES

- Reduce pressure in the supply line.

The pressure in the pipe can be reduced by pushing the plug of the pneumatic connection as far as it will go.

- Slide out the filter lock (1).

Hold the filter cover (2) with your other hand. After removing the slide, the cover will be pushed out by the spring located in the filter housing.

- After removing the slide, the cover

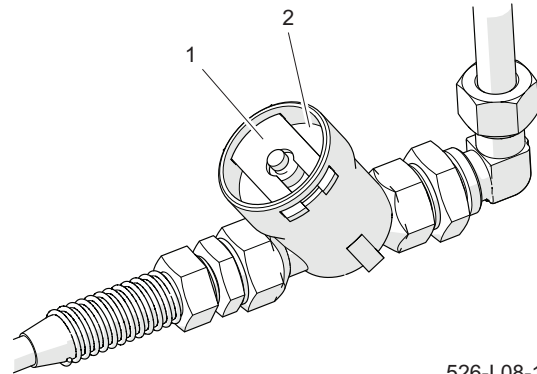

526-I.08-1

Figure 5.7 Air filter

(1) filter (2) cover

will be pushed out by the spring located in the filter housing. Installation should be in reverse order.

I.3.4.622.10.1.EN

5.10 CHECKING BRAKE LINING WEAR

- Find the inspection hole.

Depending on the version of the road axle, the inspection hole may be located in a different place than the figure shows, but it will always be located on the brake shield.

- Remove the upper and lower plugs and then check the thickness of the lining.
- The brake shoes should be replaced if the thickness of the brake lining is less than 5 mm.
- Check the remaining linings for wear.

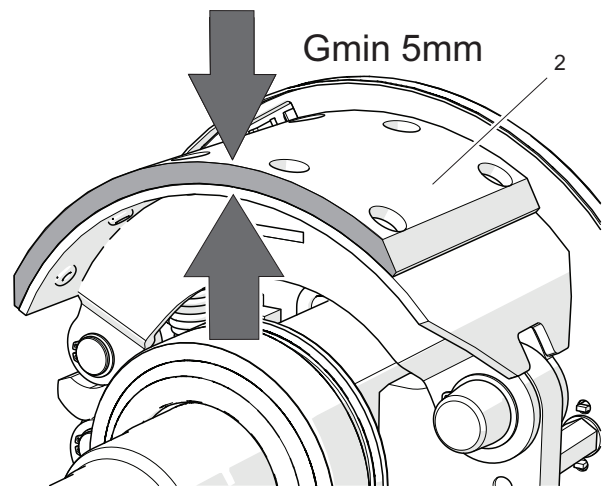
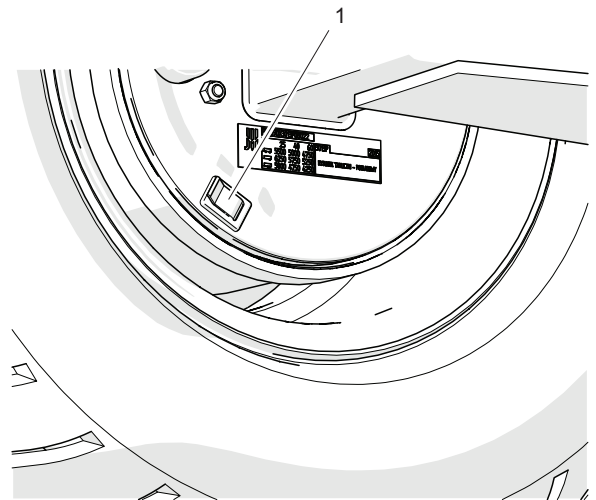

526-I.09-1

Figure 5.8 Checking the brake lining thickness

(1) blanking plug (2) brake lining

I.3.4.622.11.1.EN

5.11 CHECKING THE CLEARANCE OF THE AXLE BEARINGS

- Raise the wheel with a jack.
- Turn the wheel slowly in two directions. Check that the movement is smooth and the wheel rotates without excessive resistance and jamming.
- Turn the wheel so that it rotates very quickly, check that the bearing does not make any unusual sounds.
- Try to feel looseness by moving the wheel.
- Repeat for each wheel separately, remembering that the jack must be on the opposite side of the wedges.
- If looseness is felt, adjust the bearings. Unnatural sounds coming from the bearing may be symptoms of excessive wear, dirt or damage. In this case, the bearing together with the sealing rings should be replaced or cleaned and re greased. When checking bearings, make sure that any noticeable looseness comes from the bearings, not the suspension



526-I.10-1

Figure 5.9 Clearance inspection

ADVICE

Damaged hub cover or lack thereof will cause the penetration of dirt and moisture into the hub, which will result in much faster wear of bearings and hub seals.

Bearing life depends on trailer operating conditions, load, vehicle speed and lubrication conditions.

system (e.g. looseness on the spring pins, etc.).

- Check the technical condition of the hub cover, replace if necessary.

I.3.4.622.12.1.EN

5.12 CHECKING OF MECHANICAL BRAKES

ADVICE

Checking the technical condition of the brakes:

- according to the schedule of inspections,
- before the period of intensive use.
- after repairing the braking system.
- in the event of uneven braking of the trailer wheels.

In a correctly adjusted brake the cylinder piston stroke should be within the range given in Table 5.3 and depends on the type of cylinder used. When the wheel is fully braked, the optimal angle between the expander lever and the piston rod should be approx. 90°. With this setting, the braking force is optimal. Checking the brakes consists in measuring this angle and the piston rod stroke in each wheel.

THE SCOPE OF ACTIVITIES

- Measure the distance X with the tractor brake pedal released.
- Measure the distance Y with the tractor brake pedal pressed.
- Calculate the distance difference X-Y (rod stroke).

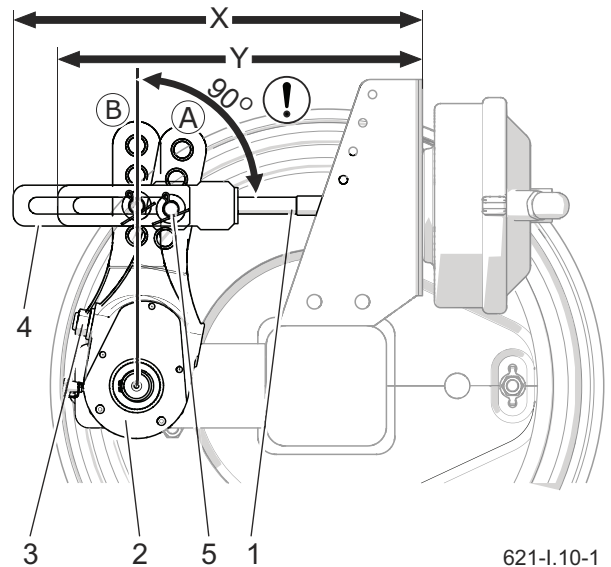

Figure 5.10 Brake check

- (1) cylinder piston (2) expander arm
- (3) adjustment screw (4) of the cylinder fork
- (5) pin position
- (A) position of the arm in the released position
- (B) arm position in braking position

- Check the angle between the cylinder piston axis and the expander lever.
- If the expander arm angle (2) and piston rod stroke exceed the range given in table 5.3, the brake should be adjusted.

I.3.4.622.13.1.EN

5.13 CLEANING THE DRAINAGE VALVE

- Fully reduce the pressure in the air reservoir (2).

The pressure in the tank can be reduced by swinging the drain valve stem.

- Unscrew the valve (1).
- Clean the valve, blow with compressed air.
- Replace the copper gasket.
- Screw in the valve, fill the tank with air, check the tank for leaks.

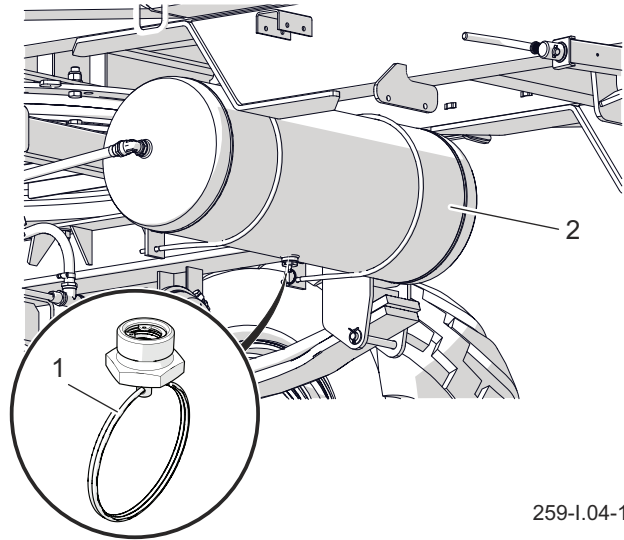

259-I.04-1

Figure 5.11 Air tank
(1) drain valve (2) tank

I.3.3.259.14.1.EN

5.14 CHECKING OF PARKING BRAKE CABLE TENSION

CABLE TENSION CONTROL

Check the parking brake after checking the mechanical brake of the axle.

- Hitch trailer to tractor. Hitch trailer to tractor.
- Place wedges under one wheel of the trailer.
- Turn the parking brake crank (2) towards (B) and apply the parking brake.
- Check cable tension (1).

When the mechanism screw is completely removed, the cable should hang about 1 to 2 cm.

CABLE TENSION ADJUSTMENT

Adjustment of parking brake cable tension should be carried out in the case of:

- cable stretching
- loosening the parking brake cable clamps,
- after adjusting the axle brake,
- after repairs to the axle brake system,
- after repairs to the parking brake system.

Before adjusting the cable, make sure that the axle brake is properly adjusted and functions properly.

To adjust:

- Unscrew the screw of the brake

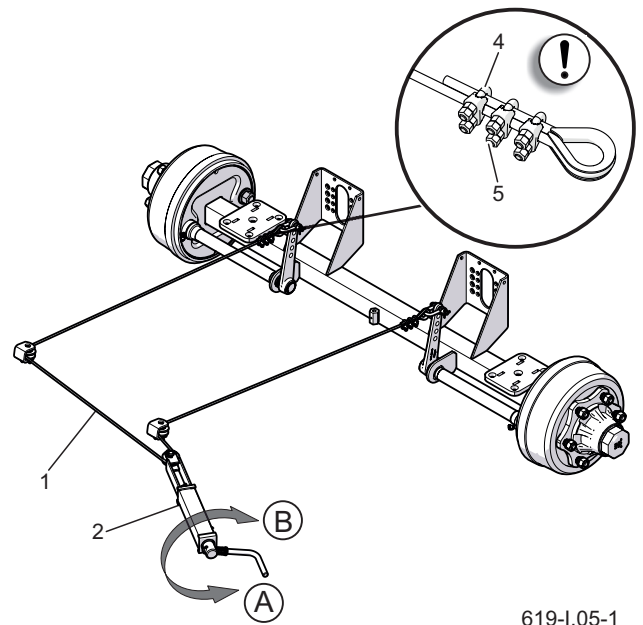

619-I.05-1

Figure 5.12 Cable tension inspection
(1) cable (2) brake mechanism (4) bow clamp (5) clamp nut

mechanism (2) maximally by turning the crank in the direction (A) (counter-clockwise).

- Loosen the nuts (5) of the bow clamps (4) on the handbrake cable (1).
- Tighten the cable (1) and tighten the nuts (4) of the clamps.
- Apply the parking brake and release it again. Check (approximately) cable tension.

When the service and parking brakes are completely released, the cable should hang about 1-2 cm. The axle trailer levers

should be in the rest position.

If it is necessary to change the brake cable, refer to chapter *Replacing the parking brake cable*”.

In the trailer version with overrun brake the parking brake adjustment is not necessary if the service (overrun) brake works correctly.



DANGER

It is forbidden to use the trailer with a defective parking brake installation.
If the trailer is damaged, it be discontinued until it is repaired.

I.3.3.619.15.1.EN

5.15 BRAKE CABLE TENSION ADJUSTMENT

In the version with overrun brake, before adjusting the cable tension, make sure that the brakes on the front axle brake simultaneously with the rear axle system. If the braking process is too early or too late, adjust the cable tension (2) - fig. 5.15

The scope of service activities:

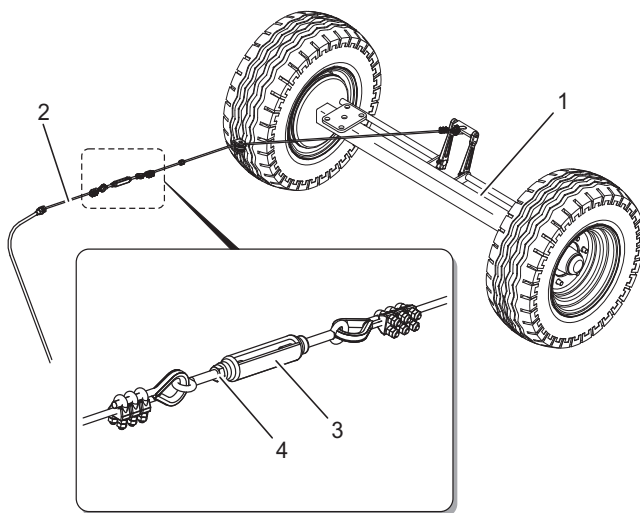

29-I.12-1

Figure 5.13 Adjustment of overrun brake cable tension

(1) rear overrun axle, (2) overrun brake cable, (3) tensioner, (4) counter nut

- Loosen the lock nut (4) of the tensioner.
- Adjust the cable length (2)
 - Tighten the cable (2) if the brakes on the rear axle brake with a delay in relation to the front axle.
 - Loosen the cable (2) if the rear axle brakes are braking ahead of the front axle.
- Tighten nut (4), check brake operation.
 - If the problem persists, repeat all steps.

Service brake control and/or adjustment:

- every 12 months.
- in case of emergency.

Brake repairs, brake lining replacements, etc. may only be performed at authorized service centres. Unauthorized repairs and modifications by the user will void the warranty. The servicing operations that can be performed by the trailer user include only brake adjustment by changing the position of the expander arms or changing the cable tension in the overrun brake.

I.3.3.619.16.1.EN

5.16 HYDRAULIC SYSTEM INSPECTION

- Hitch trailer to tractor.

Each time before connecting the trailer to the tractor or connecting a second trailer, check the hydraulic plugs and sockets.

- Secure the tractor and trailer with the parking brake.
- Clean hose connections, hydraulic cylinders and couplings.
- Start the individual hydraulic systems several times by extending and retracting the piston rods of the cylinders. Repeat operations 3-4 times.

In case of a hydraulic tipping system, perform several tipping trailers tipping backwards or to the side.

- If the trailer is equipped with hydraulic braking system, press tractor brake pedal several times.
- Check all hydraulic circuits for leaks.
If necessary tighten the connectors if moisture is visible.
- After completing the inspection, put



DANGER

It is forbidden to use the trailer with inefficient hydraulic system.
It is forbidden to use the trailer with a defective hydraulic brake system.

all cylinders to the rest position.

If visible moisture appears on the cable connectors, tighten the connector with a specified torque and carry out the test again. If the problem persists replace the leaking element.

In the event of oiling on the hydraulic cylinder body, the nature of the leakage must be checked. When the cylinder is fully extended, check the seal locations. Small leaks are permissible with symptoms of "sweating", however

in the event of noticing leaks in the form of "droplets", stop using the trailer until the fault is remedied. If a malfunction has appeared in the brake cylinders, it is forbidden to drive the trailer with a damaged system until the fault is removed.

I.3.3.259.16.1.EN

5.17 CONTROL OF PNEUMATIC SYSTEM

- Hitch trailer to tractor.
- The tractor and trailer should be immobilized with the parking brake. Additionally, place wedges under the rear wheel of the trailer.
- Start the tractor to supplement the air in the trailer braking system tank.

In double conduit systems, the air pressure should be around 6.5 bar.

- Switch off the tractor engine.
- Check the system components with the tractor brake pedal released. Air leakage is not allowed.

Pay special attention to cable connections and brake cylinders.

- Repeat the system check with the tractor brake pedal depressed.

The help of another person is required.



DANGER

It is forbidden to use the trailer with inefficient braking system.
Repair, replacement or regeneration of pneumatic system components may only be carried out in a specialized workshop.

In the event of a leak, the compressed air will leak out in places of damage with a characteristic hiss. The system leak can also be detected by coating the checked elements with washing liquid or other foaming agent, which will not aggressively affect the elements of the installation. Damaged elements should be replaced or sent for repair. If the leak appeared around the connections, user can tighten the connector on their own. If air still leaks, replace the connector components or seals with new ones.

I.3.3.259.17.1.EN

5.18 SCREW CONNECTIONS INSPECTION

TIGHTENING TORQUES FOR SCREW CONNECTIONS

During maintenance and repair work, apply appropriate tightening torques to screw connections, unless other tightening parameters are given. Recommended tightening torques for the most commonly used bolted connections are shown in the Table (5.4). The given values apply to non-lubricated steel bolts

The hydraulic hoses should be tightened with a torque of 50 -70Nm.

Check the tightness using a torque wrench. During daily inspection of the trailer pay attention to loose connections and tighten the connector if necessary. Replace lost items with new ones.

Table 5.4. Tightening torque

Metric thread	Tightening torque	
	8.8	10.9
M8	25	36
M10	49	72
M12	85	125
M14	135	200
M16	210	310
M20	425	610
M24	730	1,050
M27	1,150	1,650
M30	1,450	2,100

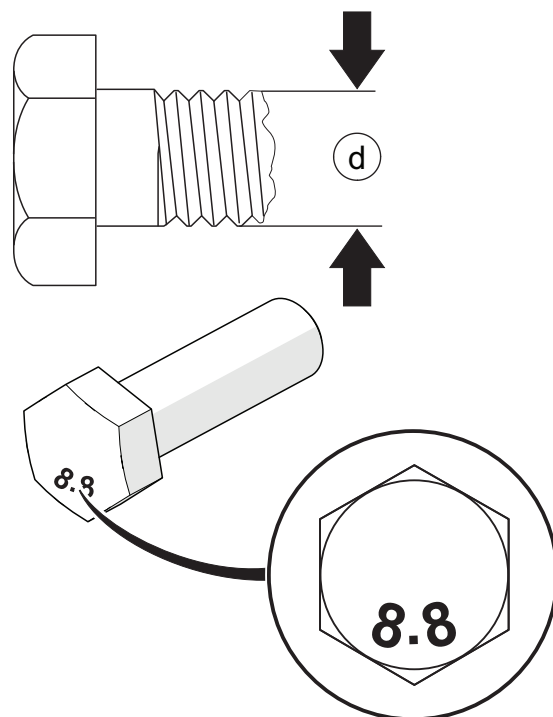

D.3-1

Figure 5.14 Metric thread screw

TIGHTENING ROAD WHEELS

The wheel nuts should be tightened gradually diagonally (in several stages until the required tightening torque is achieved), using a torque wrench. The recommended order for tightening the nuts and the tightening torque is shown in the figure Tightening of the wheel principle.

Wheel nuts must not be tightened with impact wrenches, due to the danger of exceeding the permissible tightening torque, which may result in breaking the connection thread or breaking the hub pin.

The wheels should be tightened according to the following scheme:

- after first use of the trailer (one-time inspection),
- every 2-3 hours of driving during the

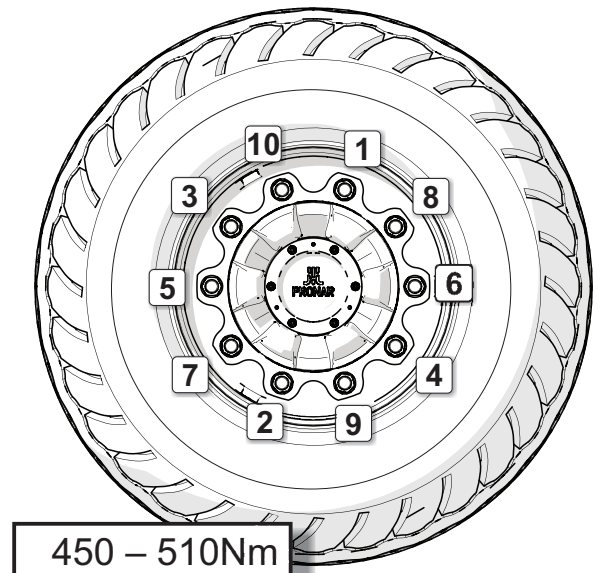

526-I.29-1

Figure 5.15 Wheel tightening principle

first month of use,

- every 30 hours of driving.

If the wheel was disassembled, the above steps should be repeated.

I.3.3.259.18.1.EN

5.19 LUBRICATION

- The trailer should be lubricated with a hand or foot grease gun, filled with the recommended lubricant. If possible, remove old grease and other contaminants before starting work. After finishing work, wipe off excess grease.
- Parts that should be lubricated using machine oil should be wiped with a dry clean cloth. Apply the oil with a brush or oiler. Wipe off excess oil.
- The replacement of grease in wheel hub bearings should be entrusted to specialized service points equipped with the appropriate tools. Dismantle the entire hub, remove the bearings and individual sealing rings. After thorough cleaning and inspection, install lubricated components. If necessary, bearings and seals be replaced.
- Empty containers of grease or oil be disposed of in accordance with the lubricant manufacturer's instructions.

Table 5.5. Lubricants

Item	Symbol	Description
1	A	general purpose machine grease (lithium, calcium),
2	B	solid grease for heavily loaded components with the addition of MOS_2 or graphite
3	C	anti-corrosive spray
4	D	plain machine oil, silicone spray grease

ADVICE

Lubrication frequency (Table *Trailer lubrication schedule*):
 D - working day (8 hours of trailer),
 M-month

I.3.3.259.19.1.EN

Table 5.6. Trailer lubrication schedule

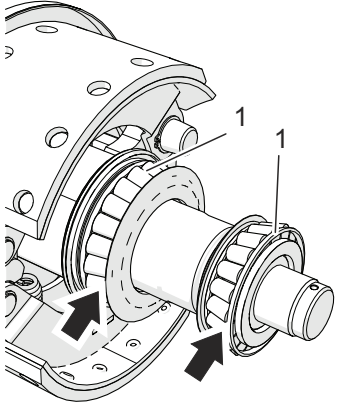
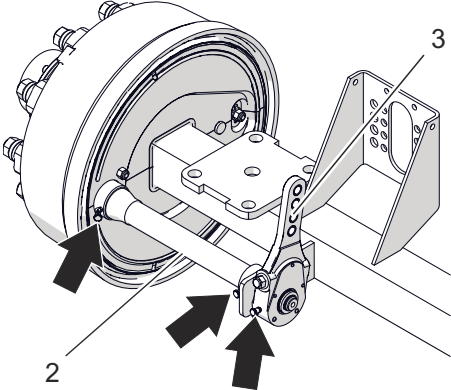
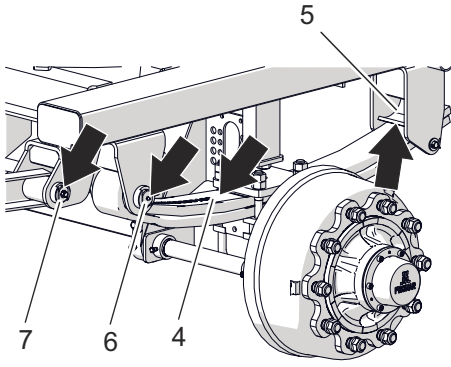
Item	Name	Number of points	Type of grease	Frequency	
1	Hub bearings (2 in each hub)	8	A	24M	
2	Camshaft sleeves	8	A	3M	 <p data-bbox="1394 1323 1490 1346">259-I.07-1</p>
3	Expander arm	4	A	3M	
4	Spring leaves	4	C	3M	 <p data-bbox="1394 1787 1490 1809">259-I.08-1</p>
5	Spring surfaces	4	B	1M	
6	Spring pin	4	B	1M	
7	Drawbar bolt	2	B	1M	

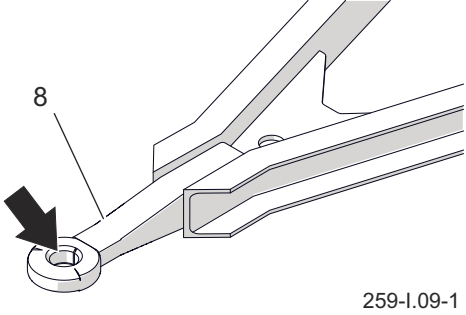
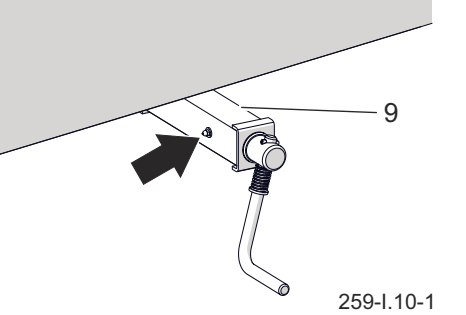
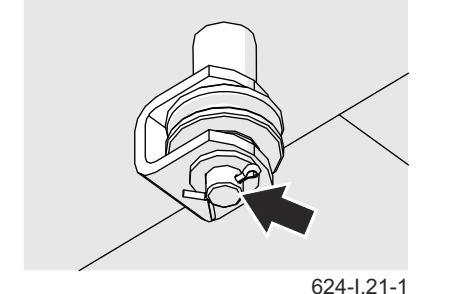
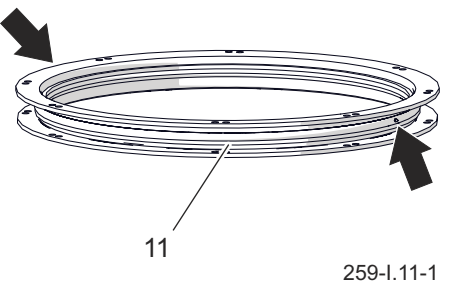
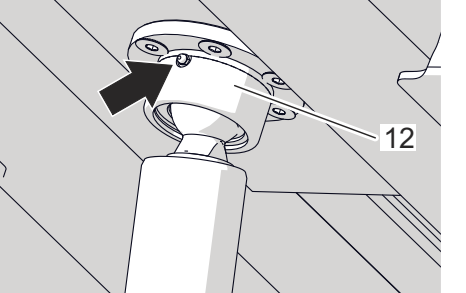
Item	Name	Number of points	Type of grease	Frequency	
8	Drawbar eye	1	B	14D	 <p>259-I.09-1</p>
9	Parking brake mechanism	1	A	6M	 <p>259-I.10-1</p>
10	Parking brake guide roll pin	3	A	3M	 <p>624-I.21-1</p>
11	Turntable bearings	2	A	24M	 <p>259-I.11-1</p>
12	Seat of the tipping cylinder ball	1	B	3M	 <p>259-I.12-1</p>

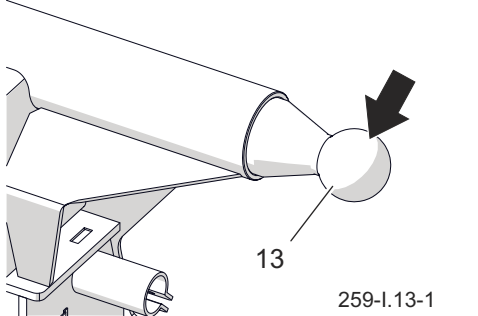
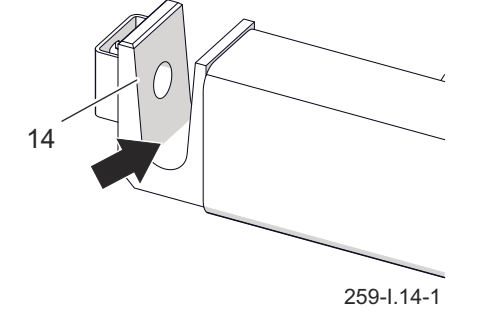
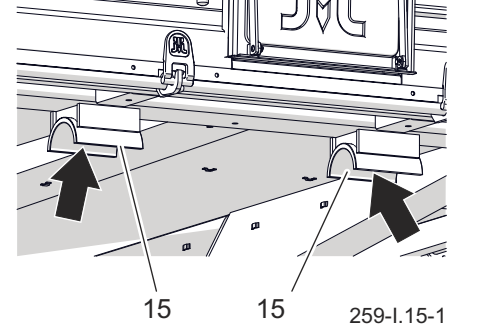
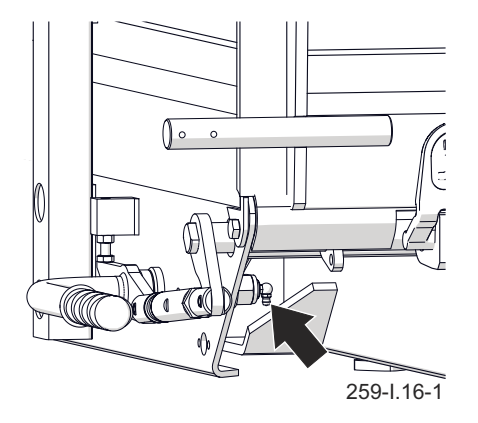
Item	Name	Number of points	Type of grease	Frequency	
13	Joints and sockets of the loading body - rear	2	B	2M	
14	Joints and sockets of the loading body - front	2	B	2M	
15	Loading box saddle sockets	2	B	2M	
16	Side walls locking mechanism	2	A	6M	

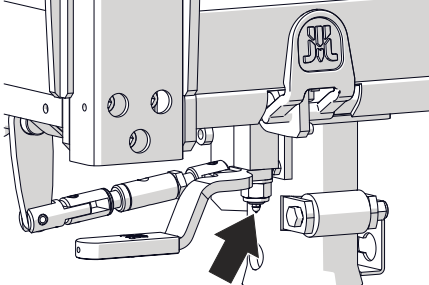
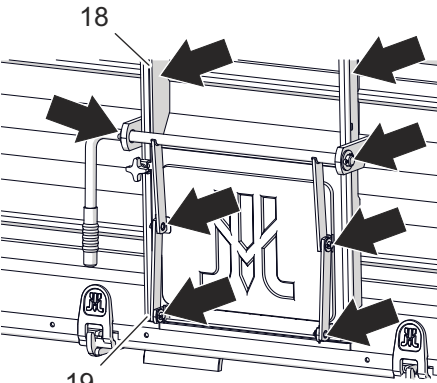
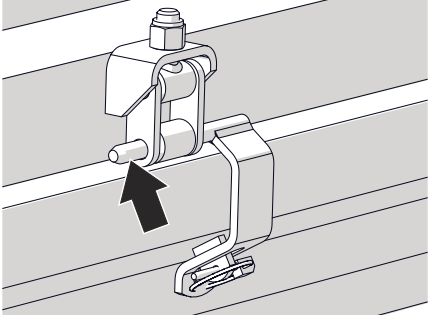
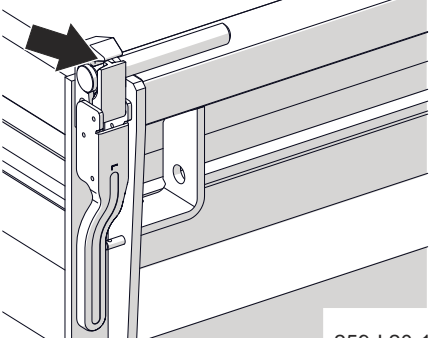
Item	Name	Number of points	Type of grease	Frequency	
17	Rear wall locking mechanism	1	A	6M	 <p>259-I.17-1</p>
18	Chute guides	2	D	1M	 <p>259-I.18-1</p>
19	Chute tie pins	6	D	1M	
20	Upper wall hinge	12	D	1M	 <p>259-I.19-1</p>
21	Bolts and wall locks	12	A	1M	 <p>259-I.20-1</p>

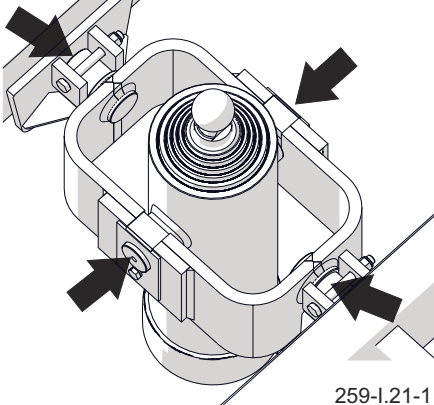
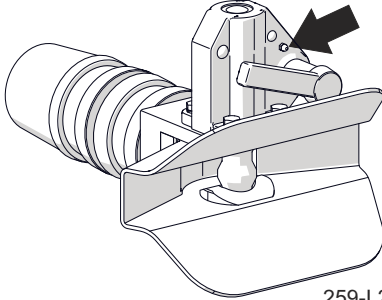
Item	Name	Number of points	Type of grease	Frequency	
22	Tipping cylinder seats and cylinder sling	4	B	1M	 <p>259-I.21-1</p>
23	Rear hitch mechanism (option)	1	A	1M	 <p>259-I.22-1</p>

5.20 REPLACEMENT OF HYDRAULIC HOSES

Rubber hydraulic and pneumatic rubber hoses should be replaced every 4 years, regardless of their technical condition, unless damage has been found before. This operation should be entrusted to specialized workshops.

I.3.3.259.20.1.EN

CHAPTER 6

TECHNICAL SUPPORT

6.1 WHEEL ASSEMBLY AND DISASSEMBLY

WHEEL DISASSEMBLY

- Before lifting the wheel that will be removed, loosen the wheel nuts in the order given in the drawing.
- Before lifting the wheel that will be removed, loosen the wheel nuts in the order given in the drawing.
- Place the jack under the axle between the spring mount bolts (See chapter: Preparation of the trailer).

The used lift should have adequate load capacity, it should be technically sound.

- If necessary, use properly selected sleepers to reduce the unit pressure of the lift base on the ground to prevent penetration into the ground.
- Raise the trailer to such a height that the wheel being changed does not rest on the ground.
- Remove the wheel.

WHEEL MOUNTING

- Use a wire brush to clean the axle pins and nuts from dirt. If necessary, degrease the thread.

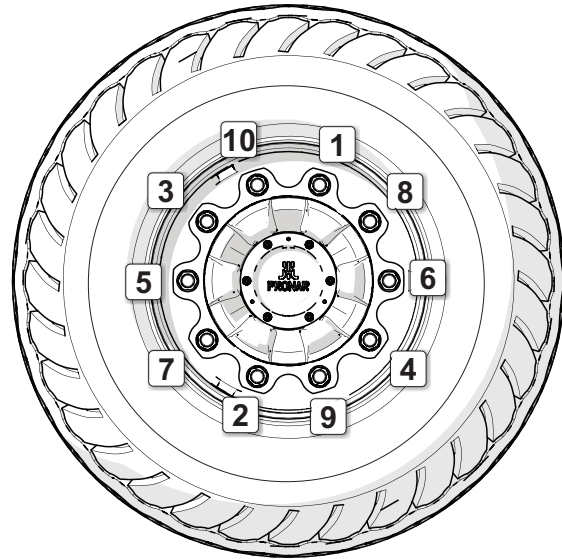

526-I.14-1

Figure 6.1 The order of the nuts tightening



DANGER

Before starting work, read the instructions for the lift and follow the manufacturer's instructions. The lift must stand firmly against the ground and the axle. Ensure that the trailer will not roll during wheels re-assembly.

Do not lubricate the threads of the nut and stud.

- Check the condition of the pins and nuts, replace if necessary.
- Mount the wheel on the hub, tighten the nuts so that the rim fits snugly to the hub.
- Lower the trailer, tighten the nuts according to the recommended torque and the given order.

J.3.4.622.01.1.EN

6.2 PARKING BRAKE CABLE REPLACEMENT

- Hitch trailer to tractor. Hitch trailer to tractor.
- Place wedges under one wheel of the trailer.
- Unscrew the brake crank bolt (2) as far as possible.
- Loosen the nuts (4) of the bow clamps (5) at the ends of the cable (1).
- Remove the shackles (6), pins, clamps (5) and cable,
- Clean the parking brake components.
- Lubricate the parking brake crank mechanism and the cable guide pins.
- Install a new cable, adjust cable tension.

Thimbles and three clamps must be fitted at the ends of the rope. Pay attention to the correct positioning of the terminals cable tension - see figure.

- Install pins and new securing pins.
- Adjust of parking brake cable tension

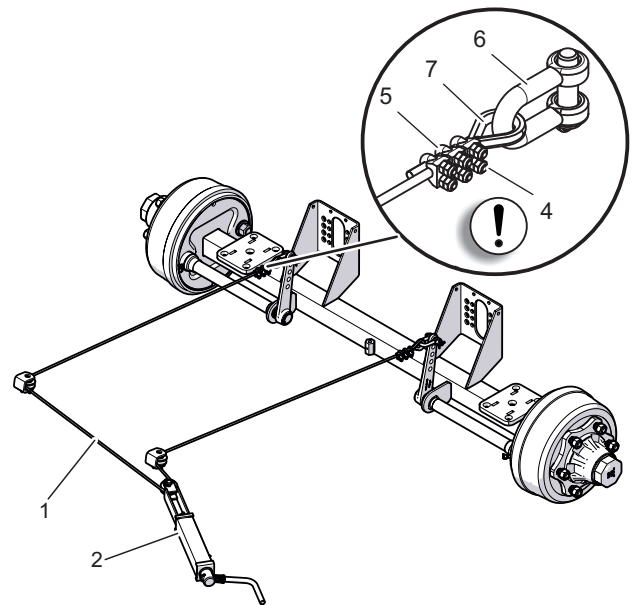

619-J.01-1

Figure 6.2 Parking brake cable replacement
 (1) brake cable I, (2) brake mechanism,
 (4) nut, (5) clamp, (6) shackle, (7) thimble

- After the first brake loading, check the tension and condition of the cable ends, adjust if necessary.



CAUTION

Clamp jaws must be placed on the load-carrying cable side - see figure.
 Secure the ends of the cable with a shrink tube.
 The first clamp must be placed as close to the thimble as possible.

J.3.3.619.02.1.EN

6.3 ADJUSTING THE CLEARANCE OF THE AXLE BEARINGS

- Remove the hub cover (1).
- Remove the cotter pin (2) securing the castellated nut (3).
- Tighten the castellated nut to remove slack.

The wheel should rotate with slight resistance.

- Unscrew the nut (3) (not less than 1/3 of a turn) to cover the nearest groove of the nut with a hole in the journal of the axle (the pin's hole is marked with a black arrow in the drawing). The wheel should rotate without excessive resistance.

The wheel should rotate without excessive resistance. Too much pressure is not recommended due to deterioration of bearing operating conditions.

- Secure the castellated nut with a cotter pin and mount the hub cover (1).
- Gently tap the hub with a rubber or wooden hammer.

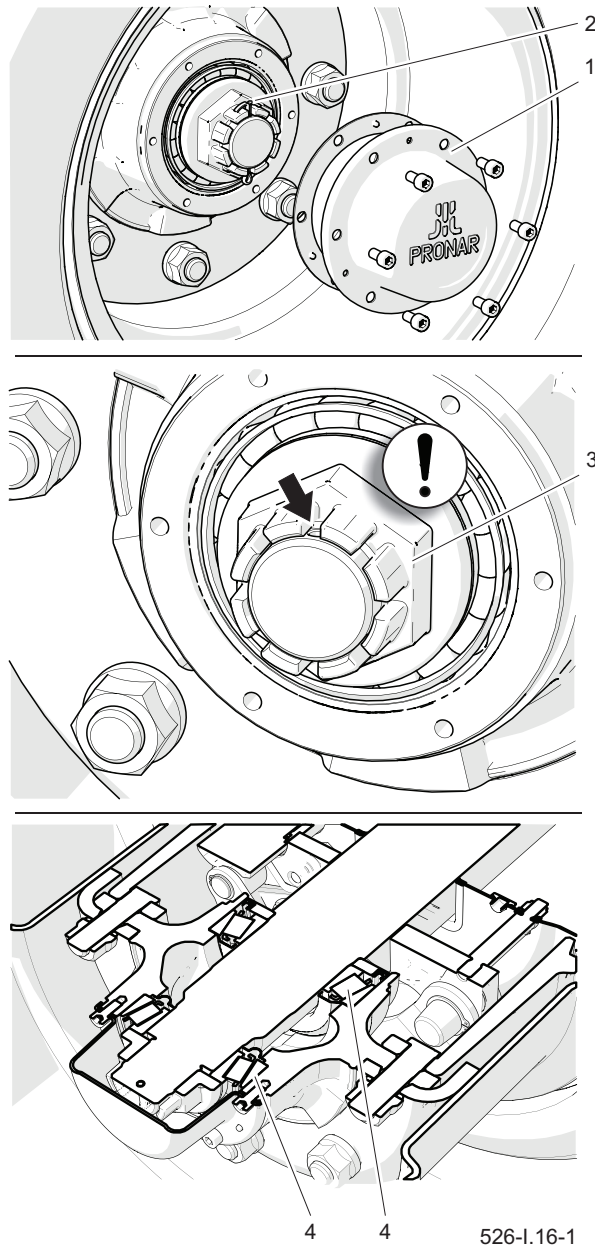

Figure 6.3 The principle of bearing clearance adjustment

- 1) hubcap (2) cotter pin
 (3) nut (4) tapered roller bearing



CAUTION

Adjustment of bearing looseness may be performed only when the trailer (without load) is connected to the tractor.

6.4 ADJUSTMENT OF BRAKES

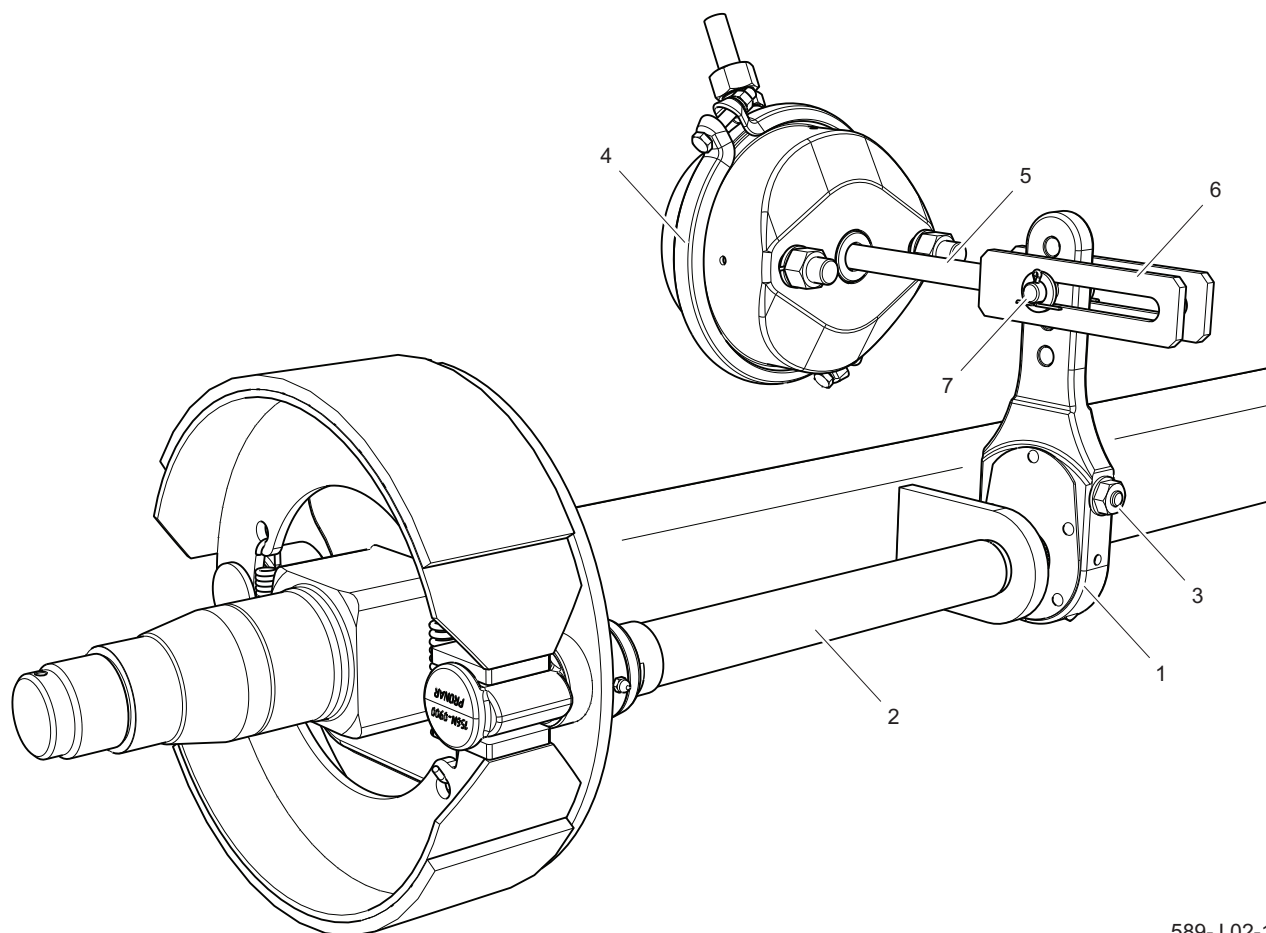

589-J.02-1

Figure 6.4 Construction of pneumatic axle brake

(1) expander arm, (2) expander shaft, (3) adjustment screw, (4) pneumatic cylinder, (5) cylinder piston rod, (6) cylinder fork, (7) cylinder pin

Significant wear of the brake linings increases the stroke of the brake cylinder piston and deteriorates braking performance.

ADVICE

The correct stroke of the piston rod should be in the range of 25 -45 mm.

When braking, the piston rod stroke should be within the specified working range, and the angle between the piston rod (1) and

the expander arm (3) should be approximately 90 ° - Figure (6.7) i (6.8). The trailer wheels must brake simultaneously.

The braking force also decreases when the angle of operation of the brake cylinder piston rod (5) is not correct - figure (6.5), (6.6) in relation to the expander arm (1). To obtain the optimum mechanical angle of operation of the piston rod fork (6) must be mounted on the expander arm (1) so that when fully braked the angle of

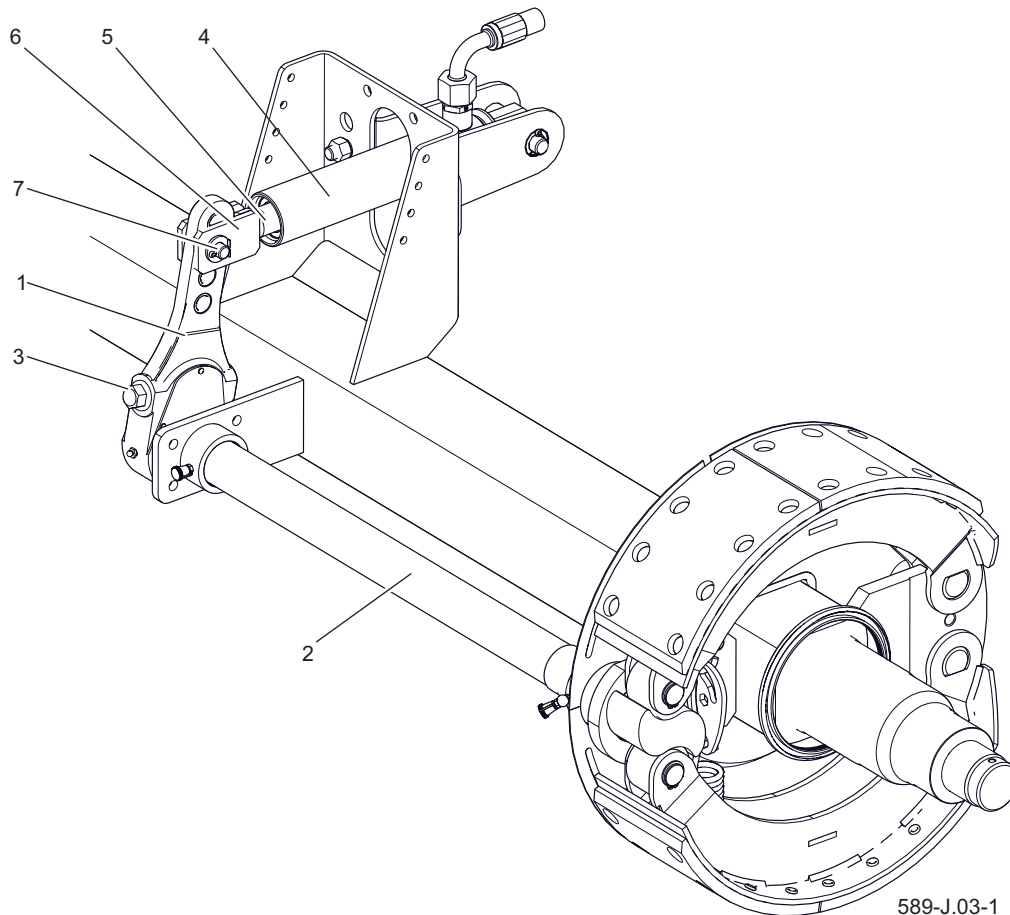

Figure 6.5 Construction of hydraulic axle brake

(1) expander arm, (2) expander shaft, (3) adjustment screw, (4) hydraulic cylinder, (5) cylinder piston rod, (6) cylinder fork, (7) cylinder pin



CAUTION

An improperly adjusted brake can cause the rubs to rub against the drum, which can result in faster wear of the brake linings and / or overheating of the brake.

position depends on the type of braking system and the size of the tires used in the trailer, it is selected by the Manufacturer and cannot be changed.

operation is approx. 90 °.

The control consists in measuring the extension length of each piston rod during braking at a standstill. If the piston rod stroke exceeds the maximum value (45mm), the system should be adjusted.

When removing the cylinder fork (6), remember or mark the original position of the cylinder fork pin (7). The mounting



CAUTION

The mounting positions of the brake cylinder in the bracket holes and the cylinder pin in the expander arm are determined by the Manufacturer and cannot be changed. Whenever removing the pin or actuator, it is recommended to mark the location of the original attachment.

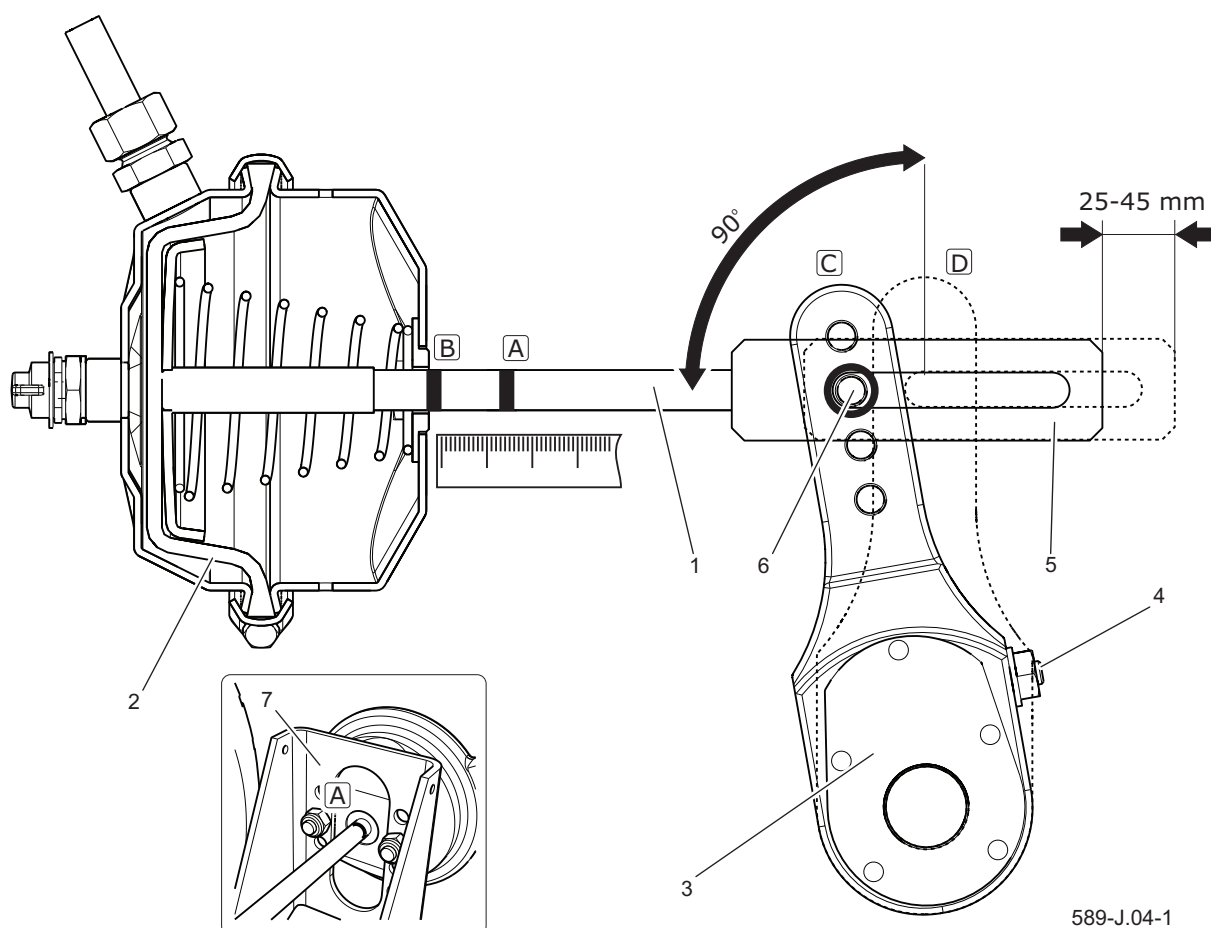

Figure 6.6 Pneumatic brake adjustment

(1) cylinder piston, (2) cylinder diaphragm, (3) expander arm, (4) adjustment screw, (5) fork of the cylinder, (6) fork of the fork, (7) cylinder of the cylinder, (A) mark on the piston rod in the braked position, (B) mark on the piston rod in the fully braked position, (C) position of the arm in the unlocked position, (D) arm position in full braking position

THE SCOPE OF ACTIVITIES

- Hitch trailer to tractor.
- Turn off the tractor engine and remove the keys from the ignition.
- Immobilize tractor with parking brake.
- Make sure the trailer is not braked.
- Secure trailer against rolling with wheel chocks.
- On the piston rod (1) - figure (6.7), (6.8) of the cylinder mark with a line (A) the position of the maximum retraction of the piston rod with the trailer brake off.
- Press the brake pedal on the tractor, mark with a line (B) the position of maximum extension of the piston rod.
- Measure the distance between the lines (A) and (B). If the piston rod stroke is not within the correct working range (25-45mm), adjust the expander arm.
- Remove the actuator fork pin (6).
- Remember or mark the original position of the cylinder fork (6) in the

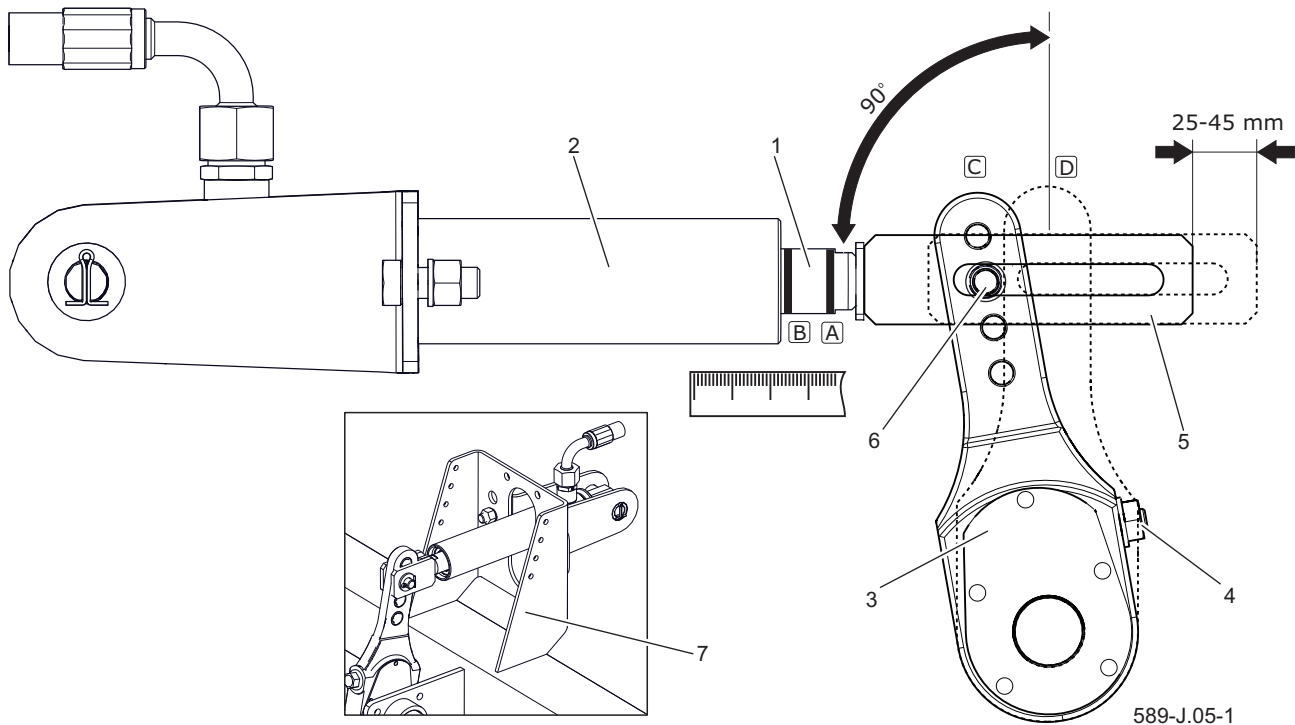

Figure 6.7 Hydraulic brake adjustment

(1) cylinder piston, (2) cylinder housing, (3) expander arm, (4) adjustment screw, (5) fork of the cylinder, (6) fork of the fork, (7) cylinder of the cylinder, (A) mark on the piston rod in the braked position, (B) mark on the piston rod in the fully braked position, (C) position of the arm in the unlocked position, (D) arm position in full braking position

expander arm bore (3).

- Check that the cylinder piston moves freely and within the full nominal range.
- Check that the air vents of the actuator are not clogged with dirt and that there is no water or ice inside (pneumatic actuator). Check the correct mounting of the actuator.
- Clean the actuator, defrost if necessary and remove water through the vent holes. (pneumatic cylinder). If damage is found, replace the actuator with a new one. When mounting the actuator, keep its original position



CAUTION

The diaphragm actuator should not be opened. The membrane is pasted and may lose its seal.

relative to the bracket (7).

- Turn the adjusting screw (4) so that the marked hole of the expander arm coincides with the hole of the cylinder fork

During adjustment, the diaphragm (2) must rest on the rear wall of the cylinder - figure (6.7) (pneumatic cylinder).

- Install the piston rod fork pin and washers and secure the pin with

cotter pins.

- Turn the adjusting screw (4) clockwise to make one or two clicks in the expander arm adjustment mechanism.
- Repeat the adjustment on the second cylinder on the same axis.
- Apply the brake.
- Wipe previous markings and measure piston rod stroke again.
- If the piston rod stroke is not within the correct operating range, repeat

the adjustment.

FUNCTIONAL CHECK

- After completing the adjustment, carry out a test drive.
- Perform several brakes. Stop the trailer and check the temperature of the brake drums.
- If any drum is too hot, correct the brake adjustment and perform the test drive again.

J.3.3.259.04.1.EN

6.5 ELECTRICAL SYSTEM SERVICE AND WARNING ELEMENTS



CAUTION

Driving with defective lighting installations is prohibited. Damaged lamps should be replaced immediately before driving off. Lost or damaged reflectors should be replaced with new ones.

Before travelling, make sure that all lamps and reflectors are clean.

Electrical installation service is reduced to periodic inspection of the control system and lighting system.

Work related to the repair, replacement or regeneration of electrical installation components should be entrusted to specialized workshops that have appropriate technologies and qualifications to perform this type of work.

The user's duties include only technical inspection of the electrical installation and reflectors.

THE SCOPE OF ACTIVITIES

- After aggregating the trailer with the tractor, connect the power supply cable for the lighting installation.

Make sure the connection cable is OK. Check the connection sockets on the tractor and on the trailer. If necessary, clean all dirt and dust.

- Check the completeness, technical

condition and correct functioning of the trailer lighting.

Check the wiring harness for damage (rubbed insulation, wire break, etc.). Check the completeness of lamps and all reflectors.

In the event of a burn, the bulb must be replaced immediately. The trailer bulbs are presented in table (6.1). All lamp shades of lighting lamps are mounted with screws and there is no need to disassemble the entire lamp or trailer components.

- Check the correct installation of the triangular plate holder for slow moving vehicles.
- Before travelling on a public road, make sure that the tractor has a reflective warning triangle.

Table 6.1. List of bulbs used in the lighting installation of the PT612 trailer

Name	Unit	Bulb	Number of lamps	Number of bulbs
Multifunctional rear right lamp	W21L	R10W P21W	1	1 3
Multifunctional rear left lamp	W21P	R10W P21W	1	1 3
License plate lighting lamp	LT-120	C5W-SV8,5	2	1
Front plate lamp	LO-110PP	C5W-SV8,5	1	1
Clearance lamp	J.K-1.6	R5W	2	2

J.3.3.619.07.1.PL

6.6 CONSUMABLES

HYDRAULIC OIL

It is absolutely necessary to observe that the oil in the trailer's hydraulic system and the tractor's hydraulic system must be of the same type. If different types of oil are used, make sure that both hydraulic means can be mixed together. The use of different types of oil may cause damage to the trailer or agricultural tractor. The new machine is filled with L HL32 Lotos hydraulic oil.

If you need to change the hydraulic oil for another oil, read the oil manufacturer's instructions carefully. If he recommends flushing the system with an appropriate preparation, follow these recommendations. It must be ensured that the chemicals used for this purpose do not act aggressively on the materials of the hydraulic system. During normal operation of the trailer, it is not necessary to change the

hydraulic oil, however, if necessary, this operation should be entrusted to specialist service centres.

The oil used, due to its composition, is not classified as a dangerous substance, however long-term effects on the skin or eyes may cause irritation. In the event of contact of oil with skin, wash the place of contact with water and soap. Do not use organic solvents (gasoline, kerosene). Soiled clothing should be removed to prevent oil from getting on your skin. If the oil gets into your eyes, flush them with plenty of water and in case of irritation contact your doctor. Hydraulic oil under normal conditions is not harmful to the respiratory tract. The hazard only occurs when the oil is strongly atomized (oil mist), or in the event of a fire during which toxic compounds may be released. Oil should be quenched with carbon dioxide, foam or

Table 6.2. Characteristics of oil L-HL 32

Item	Name	Unit	
1	Viscosity classification according to ISO 3448VG	-	32
2	Kinematic viscosity at 400C	mm ² /s	28.8 – 35.2
3	Qualitative classification according to ISO 6743/99	-	HL
4	Quality classification according to DIN 51502	-	HL
5	Flash-point	C	230

extinguishing steam. Do not use water to extinguish a fire.

LUBRICANTS

For heavily loaded parts, it is recommended to use lithium grease with the addition of molybdenum disulphide (MOS₂) or graphite. For less loaded components, it is recommended to use general-purpose machine greases that contain anti-corrosive additives and are highly resistant to water washout. Aerosol preparations (silicone greases, anti-corrosive lubricants) should have similar properties.

Before using lubricants, Z read the information leaflet for the selected product. Particularly important are safety rules and how to handle a given lubricant and how to dispose of waste (used containers, contaminated rags, etc.). The information leaflet (product card) should be kept together with the grease.

ADVICE

Lubrication frequency (*TableSpreader lubrication schedule*):

Table 6.3. Lubricants

Item	Symbol	Description
1	A	general purpose machine grease (lithium, calcium),
2	B	solid grease for heavily loaded components with the addition of MOS ₂ or graphite
3	C	anti-corrosive spray
4	D	plain machine oil, silicone spray grease

J.3.4.622.09.1.PL

6.7 TROUBLESHOOTING

Table 6.4. Faults

Fault	Possible cause	Solution
Trouble with starting.	Brake system lines not connected.	Connect the brake lines.
	Parking brake applied.	Release the parking brake.
	Pneumatic connection lines damaged.	Replace.
	Connection leakage.	Tighten, replace washers or sealing sets, replace hoses.
	Defective control valve or braking force regulator.	Check valve, repair or replace.
	Low pressure in the pneumatic system.	Fill the system with the correct pressure.
Noise in the hub of the axle.	Excessive bearing looseness.	Check the clearance and adjust if necessary.
	Damaged bearings.	Replace bearings.
	Damaged hub components.	Replace.
Low braking efficiency.	System pressure too low.	Check the pressure on the pressure gauge on the tractor, wait for the compressor to fill the tank to the required pressure.
	System leakage.	Check systems for leaks.
	Damaged tractor air compressor.	Repair or replace.
	Damaged brake valve on the tractor.	Repair or replace.

Fault	Possible cause	Solution
Excessive heating of the axle hub.	Incorrectly adjusted service or parking brake.	Adjust the expander arm positions or parking brake cable tension.
	Worn brake pads.	Replace brake shoes.
Incorrect hydraulic system operation.	Incorrect hydraulic oil viscosity.	Check oil quality, make sure that the oils in both machines are of the same grade. If necessary, change the oil in the tractor and / or trailer.
	Insufficient tractor hydraulic pump performance, tractor hydraulic pump defective.	Check the hydraulic pump on the tractor.
	Damaged or dirty actuator.	Check the cylinder piston rod (bending, corrosion), check the cylinder for leaks (piston rod seal), repair or replace the cylinder if necessary.
	Actuator load too high.	Check and reduce the cylinder load if necessary.
	Damaged hydraulic lines.	Check and make sure that the hydraulic hoses are tight, not kinked and properly tightened. Replace or tighten as necessary.
	Contaminated hydraulic oil.	Check oil cleanliness, replace filters, change oil. clean the tank.
	Incorrect oil level.	Check oil level and make up for leaks.
	Deregulated valves or limit switches	Adjust limit valves and limit switches
The individual functions of the machine do not work.	Hydraulic system hoses not connected or not connected correctly.	Check the connection and connect the cables in accordance with the operating instructions.
	Trailer control electrical system not connected.	Check the connection and connect the cables in accordance with the operating instructions.

Fault	Possible cause	Solution
Excessive wear of the left and right shoulder tires on both sides.	System pressure too low. Too high cornering speed. Too fast air loss due to damaged rim, valve, puncture e.g.	Check air pressure. Check the road tires for proper inflation regularly. Reduce speed when cornering on a hardened surface. Check rim and valve. Replace damaged parts.
Excessive tire wear in the centre.	Air pressure too high.	Check air pressure. Check the road tires for proper inflation regularly.
Excessive unilateral wear on the left or right shoulder tires.	Incorrect convergence. Driving axes incorrectly set.	Damaged spring leaf on one side of the suspension. Replace the springs.
Tread wear.	Damaged suspension system, broken spring. Damaged braking system, brake blocking, incorrectly adjusted braking system. Too frequent and sudden braking.	Check the slack in the suspension system, check the springs. Replace damaged or worn parts. Check the braking system for malfunctions. Adjust the trailer levers.
Lateral fracture.	Long-lasting ride on tires with low air pressure. Machine load too high.	Check air pressure regularly. Check the weight of the load during loading.
Abrasions on the lateral outer edge of the tire.	Too frequent climbing over sharp, high obstacles (e.g. curbs).	Control the driving technique.
Rim damage (hardening and cracking around the rim), tire crumbling.	Incorrect braking technique. Too frequent sudden braking. Damaged braking system.	Check braking system. Control braking technique. Damage arises due to excessive heating of the hub and the resulting wheel rims.

J.3.3.259.07.1.PL

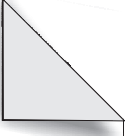

A series of horizontal lines for writing, consisting of 25 evenly spaced lines across the page.

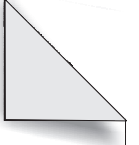

A series of horizontal lines for writing, spaced evenly down the page.

APPENDIX A

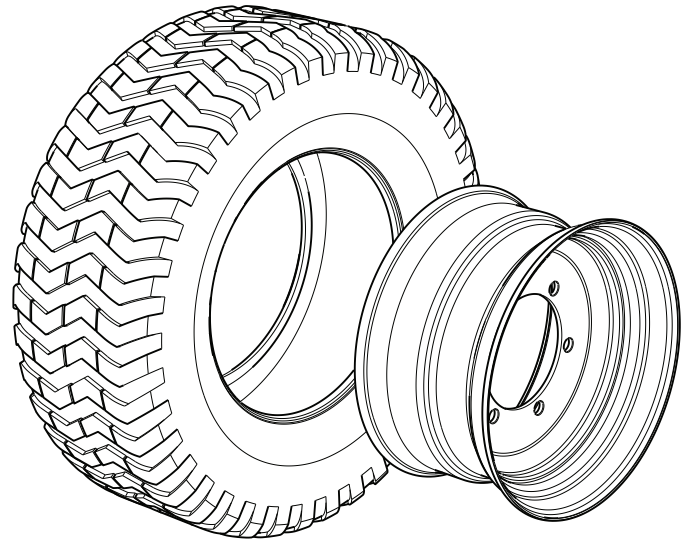

Table A.1. Tire assembly

Item	Tire	Rim	Pressure
1	11.5/80 - R15.3 14PR 139A8	9.00x15.3"	400 kPa - 640 kPa ⁽¹⁾
2	355/65 - R16 14PR 145A8	11.00x16" ET=-20	
3	400/60 - R15.5 145A8	13.00x15.5" ET=-15	
4	355/60 - R18 142J	11.00x18" ET=-20	
⁽¹⁾ depending on the tire manufacturer			

