



PRONAR SP. Z O.O.

17-210 NAREW, UL. MICKIEWICZA 101A, WOJ. PODLASKIE

PHONE NO. +48 085 681 63 29

+48 085 681 64 29

+48 085 681 63 81

+48 085 681 63 82

FAX: +48 085 681 63 83

+48 085 682 71 10

www.pronar.pl

USER MANUAL

AGRICULTURAL TRAILER

PRONAR T046H

ORIGINAL MANUAL

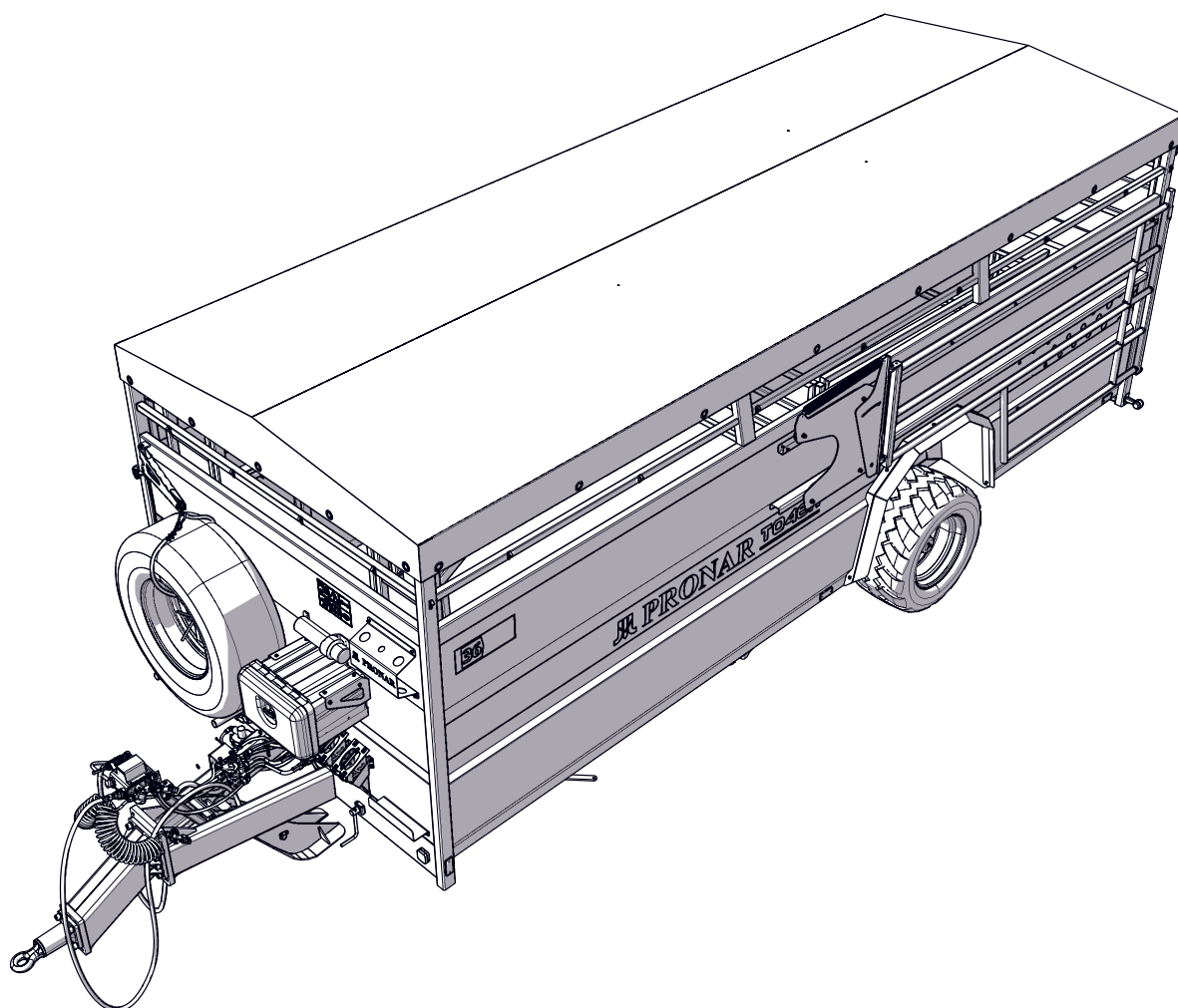

KEEP FOR FUTURE USE

ISSUE: 1A-03-2020

PUBLICATION NO: 614.00.UM



INTRODUCTION

INTRODUCTION

The information contained in the publication is current at the date of publication. As a result of improvements, some sizes and illustrations contained in this publication may not correspond with the actual state of the machine delivered to the user. The manufacturer reserves the right to introduce constructional changes in the machines manufactured to facilitate operation and improve the quality of their work, without making any current changes to this publication.

The User Manual is the basic part of the machine. Read the contents of this manual and follow all the recommendations

contained therein before using the machine. This will guarantee safe operation and ensure trouble-free operation of the machine. The machine was constructed in accordance with applicable standards, documents and current legal regulations.

If the information contained in the operator's manual is incomprehensible, please contact the sales department where the machine was purchased or directly to the Manufacturer.

After purchasing the machine, we recommend to enter the machine serial number in the fields below.

Machine serial number

This manual contains important safety and operating instructions for the machine. The manual should be kept near the machine so that it is accessible to authorized persons.

Keep this manual for future reference. If the manual is lost or damaged, contact the seller or the manufacturer for a duplicate.

The User Manual are intended for the end user. For this reason, some required maintenance is listed in the inspection tables but the procedure is not described in this publication. To perform the above, call the manufacturer's authorized service center.

U.10.1.PL

SYMBOLS USED IN THE MANUAL

DANGER

Information, descriptions of hazards and precautions as well as instructions and orders related to the safety of use in the content of the manual are marked with a frame and word **DANGER**. Non-compliance with the recommendations described will endanger the health or life of persons using the machine or bystanders.

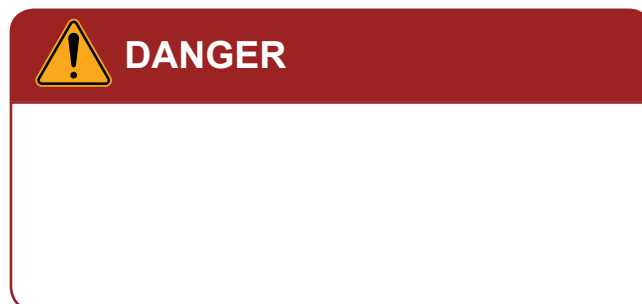

CAUTION

Particularly important information and recommendations, the observance of which is absolutely necessary, are highlighted in the text with a frame saying **CAUTION**. Failure to comply with these recommendations creates the risk of damage to the machine as a result of incorrect handling, adjustment or use.

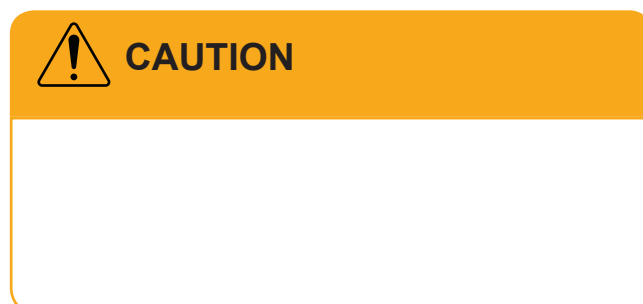

ADVICE

Additional instructions contained in the manual describe useful information on the operation of the machine and are marked with a frame with the word **ADVICE**.



U.02.1.EN

DETERMINATION OF DIRECTIONS IN THE MANUAL

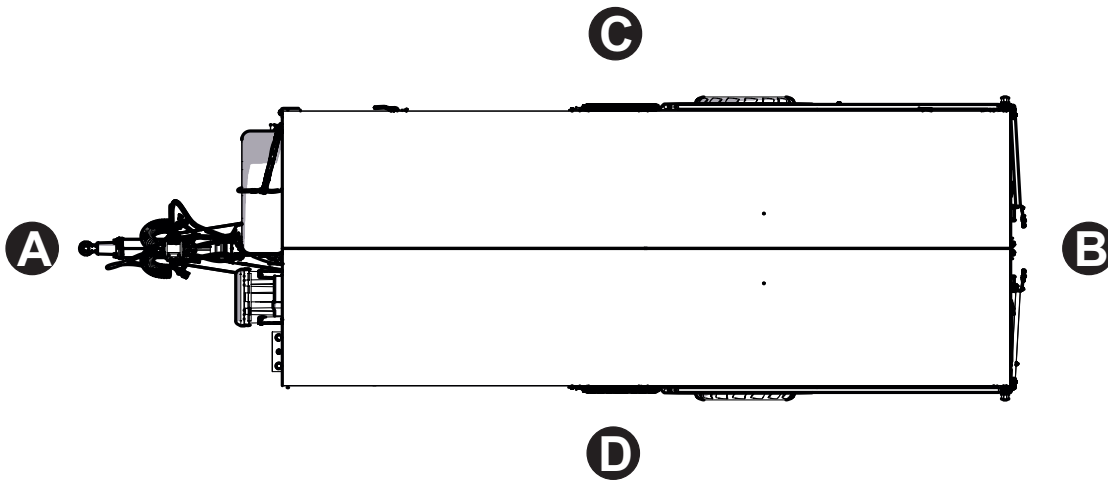

614-B.01.1

Figure 1.1 Determining directions on the machine
 (A) - front (B) rear (C) right side (D) left side

Left side - the side on the left hand of the observer facing the machine in the forward direction of travel.

Right side - the side on the right hand of the observer facing the machine in the

forward direction of travel.

Turn clockwise - turn the mechanism clockwise (operator facing the mechanism).

Turn left - turn the mechanism counter-clockwise (operator facing the mechanism).

U.03.1.EN

CONTROL OF THE MACHINE AFTER DELIVERY

The manufacturer ensures that the machine is technically sound, has been checked in accordance with control procedures and is put into service. However, this does not release the user from the obligation to check the machine after delivery and before first use. The machine is delivered to the user completely assembled. Detailed information on the transfer can be found in the *WARRANTY CARD*.

CONTROL RECOMMENDATIONS

- Check completeness of machine as ordered (standard and optional equipment).
- Check the machine for missing parts or damage resulting from incorrect transport of the machine to its destination (dents, punctures, bends or broken parts, etc.).
- Check technical condition of guards, safety devices.
- Check the condition of the paint coating, check for signs of corrosion.
- Check the condition of the tires on the road wheels and the air pressure in the tires.

ADVICE

The handover of the machine includes a detailed examination and check of its operation, as well as instruction for the buyer on the basic principles of use. The first start takes place in the presence of the Seller.

- Check the correct tightening of the road wheels.
- Check the technical condition of the drawbar eye and its fastening.
- Check the technical condition of the flexible hydraulic hoses.
- Check the technical condition of the pneumatic hoses.
- Make sure there are no hydraulic oil leaks.
- Check the machine's lighting electric lamps.
- Check the electrical controls (panel, harness).
- Check cylinders for hydraulic oil leaks.

In case of any irregularities found, report them directly to the seller to remove the defects.

U.11.2.EN

FIRST OF USE MACHINE



CAUTION

The first start-up involves checking the machine in the presence of the seller. The seller is obliged to conduct training in the safe and proper operation of the machine.

Training by the seller does not release the user from the obligation to become familiar with the contents of this manual and to follow the recommendations contained therein.

Before starting the machine, the user will be familiarized with its construction, operation principle, available equipment and operation, and first of all safety rules.

SCOPE OF ACTIONS

- Read the contents of this *USER'S MANUAL* and follow the recommendations contained therein.
- Perform a daily machine inspection in accordance with the guidelines contained in the inspection schedule.
- Check all lubrication points on the machine, lubricate if necessary according to the recommendations in the lubrication schedule.
- Check the correct tightening of screw connections (in particular the suspension, drawbar eye and road wheels).
- Make sure that the pneumatic, hydraulic and electrical connections on the agricultural tractor comply with

the requirements, otherwise do not connect the trailer.

- Make sure that the hydraulic oil in the trailer and tractor is of the same type and grade.
- Check the height of the hook position and adjust if necessary to the requirements of the containers to be handled.
- Adjust the height of the drawbar eye to the hitch on the tractor.

If all the above-mentioned activities have been carried out and the technical condition of the trailer does not raise any objections, connect the machine to the tractor.

Start the tractor, check individual systems and carry out a test run of the machine and carry out a test drive without load (with unloaded trailer). It is recommended that visual inspection be carried out by two people, one of them should be permanently in the tractor's cab. The test run must be carried out in the order shown below.

- Connect the machine to appropriate hitch of the agricultural tractor.
- Connect the brake, electrical and hydraulic system lines.
- Connect the control panel.

- Raise the support to transport position.
- Turn on the individual lights, check the correct operation of the electrical installation.
- Start and check the correct operation of the following hydraulic systems: hydraulic support (if present), front and rear axle steering locks, suspension lock, container lock, hook frame travel, lifting and lowering the swing frame.
- Check the operation of the service brake when moving off.
- Perform a test drive.
- Stop the tractor and turn off the engine, immobilize the tractor and machine with the parking brake.

If during the test run occur worrying symptoms such as:

- excessive noise and unnatural noises from rubbing moving parts,

**DANGER**

Careless and improper use and operation of the machine, as well as non-compliance with the instructions contained in the operating instructions, can pose a risk to health and life.

The machine may not be used by unauthorized persons, children, people under the influence of alcohol or other drugs.

Non-compliance with the rules of safe use poses a threat to the health of operators and bystanders.

- leakage and pressure drop in the braking system,
- improper operation of hydraulic and/or pneumatic cylinders,
- other faults,

the trailer should be stopped until the failure is removed. If the fault cannot be rectified or remedied, you will void the warranty, contact the place of purchase for clarification of the problem or for reporting the repair.

After completing the test drive, check the tightness of the wheel nuts.

U.12.3.EN



PRONAR Sp. z o.o.

ul. Mickiewicza 101 A
17-210 Narew, Polska

tel./fax (+48 85) 681 63 29, 681 63 81, 681 63 82,
681 63 84, 681 64 29

fax (+48 85) 681 63 83

http://www.pronar.pl

e-mail: pronar@pronar.pl

EC DECLARATION OF CONFORMITY OF THE MACHINERY

PRONAR Sp. z o.o. declares with full responsibility, that the machine:

Description and identification of the machinery	
Generic denomination and function:	AGRICULTURAL TRAILER
Type:	T046H
Model:	-----
Serial number:	
Commercial name:	AGRICULTURAL TRAILER PRONAR T046H

to which this declaration relates, fulfills all the relevant provisions of the Directive **2006/42/EC** of The European Parliament and of The Council of 17 May 2006 on machinery, and amending Directive 95/16/EC (Official Journal of the EU, L 157/24 of 09.06.2006).

The person authorized to compile the technical file is the Head of Research and Development Department at PRONAR Sp. z o.o., 17-210 Narew, ul. Mickiewicza 101A, Poland.

This declaration relates exclusively to the machinery in the state in which it was placed on the market, and excludes components which are added and/or operations carried out subsequently by the final user.

Narew, the 2020-01-28

Place and date

PRONAR Spółka z o.o.
17-210 Narew ul. Mickiewicza 101A
Tel. (85) 681 63 29 , 682 72 54
Fax: (85) 681 63 83
NIP 543-02-00-939, KRS 0000139188
BDO 000014169

Z-CIA DYREKTORA
d/s technicznych
działań zarządu
Roman Gwiedaniuk

*Full name of the empowered person
position, signature*

TABLE OF CONTENTS

INTRODUCTION	2
SYMBOLS USED IN THE MANUAL	3
DETERMINATION OF DIRECTIONS IN THE MANUAL	4
CONTROL OF THE MACHINE AFTER DELIVERY	5
FIRST OF USE MACHINE	6

GENERAL INFORMATION

1.1	IDENTIFICATION	1.2
1.2	AXLE IDENTIFICATION	1.3
1.3	INTENDED USE	1.4
1.4	REQUIREMENTS	1.7
1.5	EQUIPEMENT	1.8
1.6	WARRANTY CONDITIONS	1.10
1.7	TRANSPORT	1.11
	CAR TRANSPORT	1.11
1.8	THREAT TO THE ENVIRONMENT	1.13
1.9	WITHDRAWAL	1.14

SAFETY OF USE

2.1	BASIC SAFETY RULES	2.2
2.2	SAFETY DURING MACHINE AGGREGATION	2.3
2.3	LOADING AND UNLOADING ANIMALS ON A TRAILER	2.4
2.4	SAFETY RULES FOR OPERATING HYDRAULIC AND PNEUMATIC SYSTEMS	2.5
2.5	RULES OF SAFE TECHNICAL SERVICE	2.6
2.6	RULES TO MOVE ON PUBLIC ROADS	2.9
2.7	TIRES	2.11
2.8	DESCRIPTION OF RESIDUAL RISK	2.12
2.9	INFORMATION AND WARNING STICKERS	2.13

CONSTRUCTION AND OPERATION

3.1	TECHNICAL CHARACTERISTICS	3.2
3.2	GENERAL CONSTRUCTION	3.3
3.3	SERVICE BRAKE	3.4
3.4	PARKING BRAKE	3.7
3.5	THE HYDRAULIC SYSTEM OF SUSPENSION	3.8
3.6	ELECTRICAL SYSTEM, WARNING ELEMENTS	3.9

TERMS OF USE

4.1	OPERATION OF EQUIPMENT/COMPONENTS	4.2
	HYDRAULIC SUPPORT	4.2
4.2	CONNECTING AND DISCONNECTING THE TRAILER	4.3
	CONNECTING A TRAILER	4.3
	DISCONNECTING A TRAILER	4.6
4.3	HYDRAULIC SYSTEM OPERATION	4.8
4.4	LOADING	4.9
	REAR DOOR OPENING	4.9
	HYDRAULIC LOWERING OF THE TRAILER	4.9
	USING SIDE RAILINGS	4.9
4.5	TRANSPORT OF ANIMALS	4.11
4.6	UNLOADING	4.13

PERIODIC INSPECTIONS

5.1	GENERAL _____	5.2
5.2	SCHEDULE OF PERIODIC REVIEWS _____	5.3
5.3	TRAILER PREPARATION _____	5.6
5.4	AIR TANK DRAINAGE _____	5.7
5.5	CHECKING PLUGS AND CONNECTION SOCKETS _____	5.8
5.6	CHECKING THE TRAILER BEFORE DRIVING OFF _____	5.9
5.7	AIR PRESSURE MEASUREMENT, INSPECTION OF TIRES AND WHEELS _____	5.10
5.8	CLEANING THE AIR FILTERS _____	5.11
5.9	CHECKING BRAKE LINING WEAR _____	5.12
5.10	CHECKING THE CLEARANCE OF THE AXLE BEARINGS _____	5.13
5.11	CHECKING THE MECHANICAL BRAKES _____	5.14
5.12	CLEANING THE DRAIN VALVE _____	5.15
5.13	PARKING BRAKE CABLE TENSION ADJUSTMENT _____	5.16
	CABLE TENSION ADJUSTMENT _____	5.16
5.14	HYDRAULIC SYSTEM INSPECTION _____	5.18
5.15	PNEUMATIC SYSTEM INSPECTION _____	5.19
5.16	CHECKING SCREW CONNECTIONS _____	5.20
	TIGHTENING TORQUES FOR SCREW CONNECTIONS _____	5.20
	TIGHTENING OF THE WHEEL NUTS. _____	5.21
5.17	LUBRICATION _____	5.22
5.18	REPLACEMENT OF HYDRAULIC HOSES _____	5.27
5.19	REPLACEMENT OF LIMIT VALVES AND LIMIT SWITCHES _____	5.28

TECHNICAL SUPPORT

6.1	WHEEL ASSEMBLY AND DISASSEMBLY _____	6.2
	WHEEL DISASSEMBLY _____	6.2
	WHEEL ASSEMBLY _____	6.2
6.2	PARKING BRAKE CABLE REPLACEMENT _____	6.3
6.3	ADJUSTMENT OF THE CLEARANCE OF THE AXLE BEARINGS _____	6.4
6.4	BRAKE ADJUSTMENT _____	6.5
6.5	ADJUSTING THE DRAWBAR HITCH POSITION _____	6.7
6.6	OPERATION OF ELECTRICAL INSTALLATION AND WARNING ELEMENTS _____	6.8
6.7	CONSUMABLES _____	6.9
	HYDRAULIC OIL _____	6.9
	LUBRICANTS _____	6.10
6.8	TROUBLESHOOTING _____	6.11

APPENDIX A

CHAPTER 1

GENERAL INFORMATION

1.1 IDENTIFICATION

S Z B 0 4 6 0 H X

The PRONAR T046H agricultural trailer has been marked with a name plate (1) located on the side surface of the container socket and the serial number (2) stamped on the right drawbar longitudinal member. The meaning of the individual fields on the name plate is given in Table (1.1). Record the trailer's serial number in the top field.

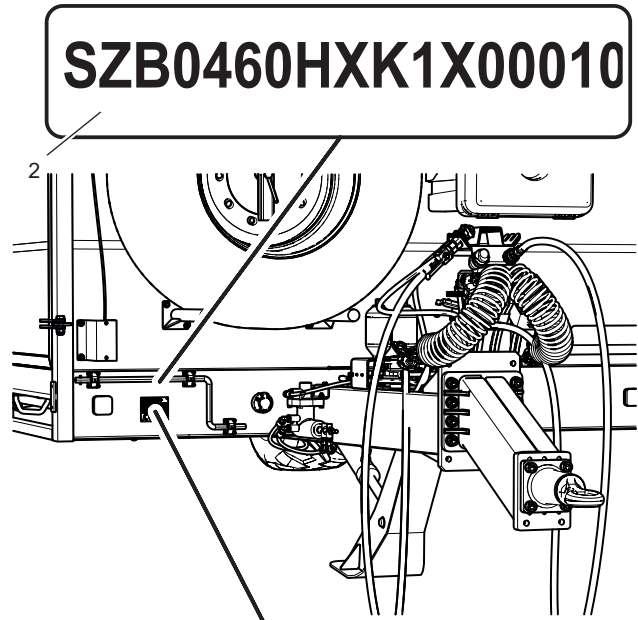
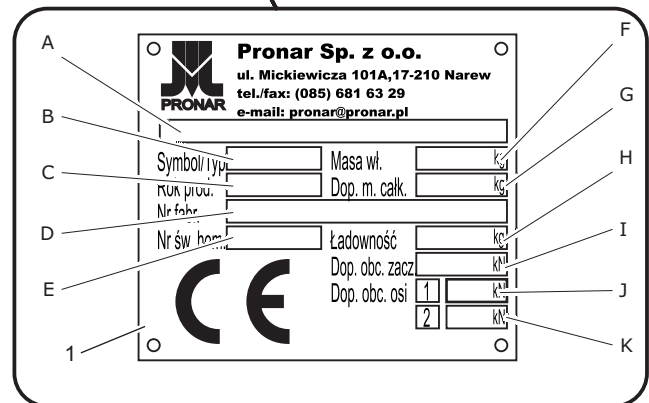

Table 1.1. Name plate markings

Item	Meaning
A	General term and function
B	Trailer symbol/type
C	Year of production
D	VIN number
E	Certificate approval number
F	Curb weight
G	Permissible gross weight
H	Capacity
I	Permissible load on coupling
J	Permissible axle load 1
K	Permissible axle load 2



614-E.01-1

Figure 1.1 Trailer identification

- (1) Name plate
(2) VIN number of trailer

E.3.9.614.01.1.EN

1.2 AXLE IDENTIFICATION

The serial number of the drive shafts and their type is stamped on the name plate (2) attached to the axle drum cover - figure (1.2). After purchasing the trailer, it is recommended to enter individual serial numbers in the fields below.

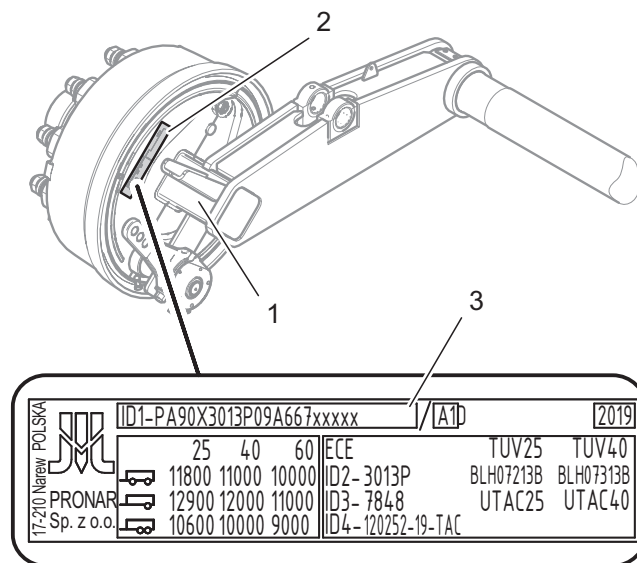

614-E.02-1

Figure 1.2 Axis identification

- (1) Driving axle
- (2) Name plate
- (3) Axle serial number

E.3.9.614.02.1.EN

1.3 INTENDED USE

The T046H trailer is intended for the transport of own livestock by farmers for seasonal grazing up to 50 km from the farm. Transported animals should be tethered.

Transport of animals should be in accordance with 'COUNCIL REGULATION (EC) NO. 1/2005 OF 22 DECEMBER 2004. ON THE PROTECTION OF ANIMALS DURING TRANSPORT AND ASSOCIATED ACTIVITIES' and Directives 64/432/EEC and 93/119/EC and Regulation (EC) No. 1255/97.

The transport of own animals by farmers should be carried out using their own means of transport (the above-mentioned trailer) meeting the general conditions of transport of animal, i.e.

- no one may transport animals or order animals to be transported in a way that mutilates them or causes them suffering.

In addition, the following conditions must be met:

- the necessary steps must be taken to minimize the duration of the transport and to ensure the needs of the animals during transport,
- animals must be able to travel,
- the trailer intended for transport is



CAUTION

Transporting free animals (without a leash) is prohibited

constructed, maintained and operated in a manner that prevents injury and suffering, and in a manner that ensures animal safety,

- loading and unloading facilities must be properly designed, constructed, maintained and operated in such a way as to prevent injury and suffering to the animals and in a manner that ensures the safety of the animal,
- personnel who takes care of animal should have the appropriate training or competence required in this case and perform their duties without using violence or any method causing unnecessary fear, injury or suffering,
- transport must be carried out without delay to the destination, while animal welfare conditions must be regularly monitored and maintained at an appropriate level,
- animals must have adequate floor area and height appropriate to their size and intended transport,
- water, feed and rest must be provided at appropriate intervals and

be appropriate to the quantity and quality of the species and size of animals concerned.

The use of the trailer in a different way than described above is not allowed. Intended use also includes all activities related to proper and safe operation and maintenance. The trailer is not intended

**CAUTION**

The trailer speed must not, however, be greater than the maximum design speed of 40 km/h.

**DANGER**

The machine must not be used for purposes other than those for which it was intended.

for people transporting.

The braking system as well as the lighting and signaling system meet the requirements arising from traffic regulations. In the countries where the trailer is used, restrictions related to the road traffic laws in force in a given country must be observed. The trailer speed must not, however, be greater than **the maximum design speed of 40 km/h.**

The running gear (half shafts, wheels and tires) meets the requirements for agricultural trailers. Meeting these requirements is conditioned by proper handling and compliance with the rules contained in this

manual. The user of the trailer is obliged to read this manual and comply with its recommendations.

Intended use also includes all activities related to proper and safe operation and maintenance of the machine. Therefore, the user is obliged to:

- read the trailer *User Manual* and *Warranty Card* and comply with the recommendations contained therein,
- understand the principle of machine operation and the safe and proper operation of the trailer,
- act in compliance with established maintenance and adjustment plans,
- act in compliance with general safety regulations during work,
- accident prevention,
- comply with road traffic regulations and transport regulations in force in the country in which the trailer is used,
- get acquainted with the contents of the farm tractor instruction manual and comply with its recommendations,
- aggregate the vehicle only with such an agricultural tractor that meets all the requirements set by the trailer Manufacturer.

The trailer may only be used by persons who:

- read the content of this publication and documents attached to the trailer as well as the content of the farm tractor operating instructions,
- have been trained in trailer operation and work safety,
- have the required authorization to drive and are familiar with the traffic rules and transport regulations.
- for loose transport of unprotected toxic materials when there is a possibility of environmental contamination,
- or transporting machines and devices whose center of gravity location has a negative effect on the stability of the trailer,
- for transporting loads that affect uneven loading and overloading of the driving axles,
- to transport unloaded loads that can change their position during travel,

The trailer may not be used for purposes other than those for which it is intended, in particular:

- to transport people,

E.3.9.614.03.1.EN

1.4 REQUIREMENTS

Table 1.2. Agricultural tractor requirements

Content	Unit	Requirements
Braking system		
Double conduit pneumatic system	-	sockets in accordance with PN-ISO 1728: 2007
Nominal pressure of the pneumatic system	kPa	650
The hydraulic system		
Hydraulic oil	-	L HL 32 Lotos ⁽¹⁾
Nominal pressure of the installation	bar	160
Electrical system		
Electrical system voltage	V	12
Connection socket	-	7 poles in accordance with ISO 1724
Minimal power requirement	kW/KM	47.8 / 65

⁽¹⁾ – other oil may be used, provided it can be mixed with prime oil

E.3.9.614.04.1.EN

1.5 EQUIPEMENT

Table 1.3. Trailer equipment.

Standard	Equipment	Additional	Optional
User Manual	•		
Warranty Card	•		
Lighting connection cable	•		
12V (LED) lighting system with clearance lighting	•		
Wheel chocks	•		
2-wire pneumatic system with manual regulator	•		
2-wire pneumatic system with ALB			•
The hydraulic system			•
Rotary cable Ø50 mm	•		
Rigid cable Ø40 mm			•
Rigid ball cable K80			•
hydraulic scissor support			•
Telescopic drawbar support with gear	•		
The hydraulic system of suspension	•		
Canvas cover set	•		
Hand brake	•		
Fixed partition (614N-12000000)		•	
Bitumen floor		•	
End gate 614N-08000000		•	
The partition on guides (614N-07000000)		•	
Barriers (614N-04000000)		•	
Spare wheel attachment		•	
Tool supports		•	
Indoor lighting		•	
Slow-moving vehicles sign		•	

Warning reflective triangle		•	
Tool box		•	
Document tube		•	

Some standard equipment items that are listed in the table may not be included in the supplied trailer. This is due to the possibility of ordering a new machine with a different set - optional equipment, replacing the standard equipment.

Tire information is provided at the end of the publication in ANNEX A.

E.3.9.614.05.1.EN

1.6 WARRANTY CONDITIONS

ADVICE

You should require the seller to carefully fill out the *Warranty Card* and complaint coupons. The lack of e.g. date of sale or point of sale stamp exposes the user to not accept any complaints.

PRONAR Sp. z o.o. in Narew guarantees the smooth operation of the machine when used in accordance with the technical and operational conditions described in the *User Manual*. The date of repair is specified in the *Warranty Card*.

The warranty does not apply to parts and sub-assemblies of the machine, which are subject to wear in normal operating conditions, regardless of the warranty period. The warranty services only apply to such cases as: mechanical damage not caused by the fault of the user, factory defects of parts, etc.

In the event that damage occurs as a result of:

- mechanical damage caused by the

- user's fault, road accident,
- from improper operation, adjustment and maintenance, misuse,
- use of a damaged machine,
- repairs carried out by unauthorized persons, improper repairs,
- making arbitrary changes in the machine design,

the user loses the warranty.

The user is obliged to immediately report all noticed defects in the paint coatings or traces of corrosion, and order removal of defects regardless of whether the damage is covered by the warranty or not.

Detailed warranty conditions are given in the *Warranty Card* attached to the newly purchased machine.

Modifications to the machine without the written consent of the Manufacturer are prohibited. In particular, welding, reaming, cutting and heating of the main machine components that directly affect safety during use are not permitted.

E.3.4.622.06.1.EN

1.7 TRANSPORT

The machine is ready for sale completely assembled and does not require packing. Only the machine's technical documentation and possibly some elements of additional equipment are packed. Delivery to the user is carried out by road or independent transport (towing a trailer with an agricultural tractor).

CAR TRANSPORT

Loading and unloading a trailer from a car should be carried out using a loading ramp using a farm tractor. During work adhere to



DANGER

Incorrect use of securing measures can cause an accident

the general principles of workplace health and safety for reloading work. Persons operating reloading equipment must have the required permissions to use these devices. The machine must be correctly connected to the tractor in accordance with the requirements contained in this manual. The trailer braking system must be activated and checked before going down or onto the ramp.

The machine should be mounted firmly on the platform of the vehicle using straps, chains, lashings or other fastening devices equipped with a tensioning mechanism.



DANGER

During road transport, the trailer must be mounted on the platform of the vehicle in accordance with safety requirements and regulations. While driving, the car driver should exercise extreme caution. This is due to the vehicle's center of gravity shifting upwards with the machine loaded. Use certified and technically reliable securing measures. Read the operating instructions of the fastener manufacturer.

Fasteners should be attached to the transport retainers provided for this purpose - figure (1.3). Transport retainers are welded to the bottom frame longitudinal members.

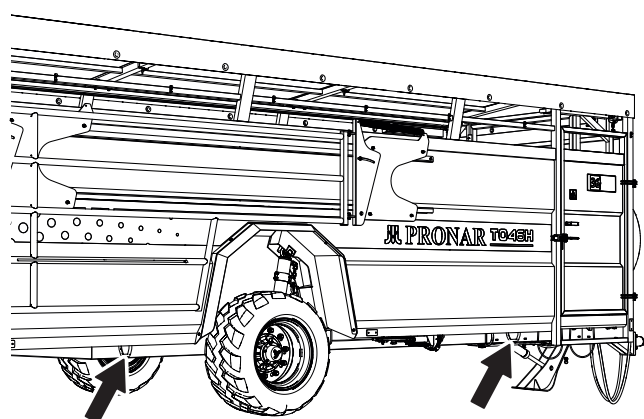

614-E.04-1

Figure 1.3 Trailer attachment points

Chocks or other objects without sharp edges should be placed under the trailer

wheels to protect the machine against rolling. Wheel locks must be secured to the vehicle loading platform in a way that prevents them from sliding.

Use certified and technically reliable securing measures. Wiping belts, cracked fasteners, bent or corroded hooks or other damage may disqualify the product from being used. Please refer to the instructions in the operating instructions of the manufacturer of the securing material used. The number of fastening elements (ropes, belts, chains, lashings, etc.) and the force needed for their tension depends, among others, on the machine's own weight, construction of the transporting car, travel speed and other conditions. Therefore, it is not possible to specify the fastening plan in detail.

In order to optimally attach the trailer to the loading platform, support the drawbar by placing a support under it in the form of a wooden block. A properly attached trailer will not change its position relative to the transporting vehicle. The fastening means must be selected according to the manufacturer's instructions. In case of doubt, a larger number of attachment and securing points for the trailer should be used.



CAUTION

It is forbidden to fasten slings and all kinds of fastening elements for the elements of the hydraulic and electric installation as well as the slender elements of the machine (e.g. covers, wires)

If necessary, protect sharp edges of the trailer, thus securing the securing means against damage during transport.

During reloading work, particular attention should be paid so as not to damage the machine equipment components and the paint coating. The tare weight of the trailer in running order is given in table (3.1).

OWN TRANSPORT

In the case of independent transport by the user after purchasing the trailer, read the trailer *User Manual* and follow its recommendations. Own transport involves towing a trailer with your own agricultural tractor to its destination. Adjust the speed to the prevailing road conditions during



DANGER

When transporting independently, the operator should read the contents of these operating instructions and observe the recommendations contained therein.

driving, but it must not be greater than the maximum design speed.

E.3.4.622.07.1.EN

1.8 THREAT TO THE ENVIRONMENT

A hydraulic oil leak constitutes a direct threat to the natural environment owing to the limited biodegradability of the substance. Maintenance and repair work at which there is a risk of oil leakage should be carried out in rooms with oil resistant surfaces. In the event of oil leaking into the environment, first of all contain the source of the leak, and then collect the leaked oil using available means. Collect oil residue with sorbents or mix the oil with sand, sawdust or other absorbent materials. Collected oil contaminants should be stored in an airtight and marked container, resistant to hydrocarbons, and then transferred to an oil waste disposal point. The container should be kept away from heat sources, flammable materials and food. Oil which has been used up or is unsuitable for further use due to the loss of its properties is recommended to be stored in its



CAUTION

Oil waste can only be delivered to a point dealing with the utilization or regeneration of oils. It is prohibited to throw or pour oil into the sewage system or water reservoirs.



DANGER

Do not store oil waste in food containers. Store used oil in containers resistant to hydrocarbons.

ADVICE

The trailer's hydraulic system is filled with L-HL 32 Lotos oil.

original packaging in the same conditions as described above. Waste code 13 01 10 (hydraulic oil). Detailed information on oils can be found in the product safety data sheets.

E.3.4.622.08.1.EN

1.9 WITHDRAWAL

If the user decides to withdraw the machine from use, comply with the provisions in force in the given country regarding withdrawal from use and recycling of machines withdrawn from use.

Before dismantling the machine, the oil from the hydraulic system and gear must be completely removed. The location of the drain plugs and the method of removing oil are described in Chapter 5.

In the event of parts being replaced, worn or damaged parts should be taken



DANGER

During dismantling, use appropriate tools and equipment (overhead cranes, cranes, lifts, etc.), use personal protective equipment, i.e. protective clothing, footwear, gloves, glasses, etc.
Avoid oil contact with skin. Do not allow oil to leak.

to a recycling centre. Used oil as well as rubber or plastic elements should be taken to plants dealing with the utilization of this type of waste.

E.1.1.586.07.1.EN

CHAPTER 2

SAFETY OF USE

2.1 BASIC SAFETY RULES

- Before using the trailer, the user should carefully read the content of this publication and the *WARRANTY CARD*. During their operation, all recommendations contained therein must be observed.
- The trailer may only be used and operated by persons authorized to drive agricultural tractors with a trailer.
- If the information contained in the Operator's Manual is difficult to understand, contact a seller who runs an authorized technical service on behalf of the manufacturer, or contact the manufacturer directly.
- Careless and improper use and operation of the machine, as well as non-compliance with the instructions contained in the operating instructions, can pose a risk to health and life.
- The trailer user is obliged to familiarize himself with the construction, principles of operation and safe operation of the trailer.
- Familiarize yourself with all machine controls before starting work. Do not start the machine without knowing its function.
- Be aware of the existence of a minimal risk of danger, therefore the application of the principles of safe use and sound behavior should be the basic principle of using a trailer.
- The machine must never be used by persons who are not authorized to drive tractors, including children, people under the influence of alcohol or other drugs, etc.
- The trailer may not be used for purposes other than those for which it was intended. Everyone who uses the trailer in a manner contrary to its intended use, thus takes full responsibility for all consequences arising from its use. Use of the machine for purposes other than envisaged by the Manufacturer is inconsistent with the purpose of the machine and may void the warranty.
- Before starting the trailer, make sure that it is properly prepared for work, first of all in terms of safety.

F.3.4.622.01.1.EN

2.2 SAFETY DURING MACHINE AGGREGATION

- It is forbidden to connect the trailer to the tractor if it does not meet the manufacturer's requirements (minimum power requirement of the tractor, inadequate connection, etc.) - see chapter *REQUIREMENTS*.
- Before connecting the trailer, make sure that the oil in the tractor's external hydraulic system can be mixed with the trailer's hydraulic oil.
- Before connecting the trailer, make sure that both machines are technically sound.
- When connecting the trailer, use the appropriate tractor hitch. After coupling the machines, check the hitch safety device. Read the tractor operating instructions. If the tractor is equipped with an automatic hitch, make sure that the coupling operation has been completed.
- Take special care when connecting the machine.
- Nobody may stay between the trailer and the tractor during connecting them.
- Coupling and uncoupling the trailer may take place only when the machine is immobilized by means of the parking brake. If the trailer stands on a slope or slope, it should be additionally secured against rolling by placing wedges under the wheels of the trailer or other elements without sharp edges under the wheels.
- The trailer cannot be moved when the support is extended and rests on the ground. There is a risk of damage to the support during machine movement.

F.3.9.614.02.1.EN

2.3 LOADING AND UNLOADING ANIMALS ON A TRAILER

- During loading and unloading the trailer must be connected to the tractor.
- Loading and unloading work should be carried out by a person experienced in this type of work.
- Animals on the trailer must be arranged as regularly as possible over the entire surface of the trailer.
- Animals on the trailer must be secured (remain tethered during transport).
- Climbing on the machine to bring animals is only possible when the trailer is absolutely stationary and the tractor engine is switched off.
- When placing animals through the side platform, do not exceed the permissible load on the platform
- When opening the door, make sure that the animals do not lean against the door, as there is a great risk of injury or crushing.
- Do not exceed the maximum load capacity of the trailer.

F.3.9.614.03.1.EN

2.4 SAFETY RULES FOR OPERATING HYDRAULIC AND PNEUMATIC SYSTEMS

- The hydraulic and pneumatic systems are under high pressure during operation.
- The technical condition of connections as well as hydraulic and pneumatic hoses should be regularly checked. The trailer's operation with leaking installations is not allowed.
- In the event of a failure of the hydraulic or pneumatic system, the trailer should be decommissioned until the failure is removed.
- When connecting the hydraulic conduits to the tractor, make sure that the tractor hydraulic system and trailer are not under pressure. If necessary, reduce the residual pressure of the system.
- In the event of injuries being caused by pressurized hydraulic oil, contact a doctor immediately. Hydraulic oil can penetrate the skin and cause infection. In the event of contact of oil with eye, rinse with large quantity of water and in the event of the occurrence of irritation consult a doctor. In the event of contact of oil with skin, wash the area of contact with water and soap. Do not use organic solvents (petrol, kerosene).
- Use hydraulic oil recommended by the manufacturer.
- After changing the hydraulic oil, the used oil must be disposed of. Used oil or oil which has lost its properties should be stored in original containers or replacement packaging resistant to hydrocarbons. Replacement containers must be accurately described and properly stored.
- It is forbidden to store hydraulic oil in packaging intended for food storage.
- Rubber hydraulic conduits must be replaced every 4 years regardless of their technical condition.

F.3.4.622.05.1.EN

2.5 RULES OF SAFE TECHNICAL SERVICE

- The trailer should be kept clean.
- During the warranty period, any repairs may only be carried out by a Warranty Service authorized by the manufacturer. After the end of the warranty period, it is recommended that any repairs to the trailer be carried out by specialized workshops.
- In the event of any faults or damage, the trailer should be decommissioned until repaired.
- During maintenance work, use appropriate, close-fitting protective clothing, gloves, shoes, glasses and the right tools.
- Any modification of the trailer releases PRONAR Narew from any liability for damage or injury.
- Climbing on the machine is possible only when the trailer is absolutely stationary and the tractor engine is switched off. Tractor and trailer should be secured with parking brake and chocks should be placed under the trailer wheel. Secure the tractor cab against unauthorized access.
- Regularly check the technical condition of the safety devices and the correct tightening of bolted connections (in particular the tendons and wheels).
- Inspect the trailer in accordance with the frequency specified in this manual.
- Before starting repair work on hydraulic or pneumatic systems, the residual oil or air pressure must be completely reduced.
- Perform maintenance and repair activities applying general principles of health and safety at work. In the event of a cut, the wound should be immediately washed and disinfected. If serious injury is sought, medical advice should be sought.
- Repair, maintenance and cleaning work should only be carried out with the tractor engine switched off and the ignition key removed. Tractor and trailer should be secured with parking brake and chocks should be placed under the trailer wheel. Secure the tractor cab against unauthorized access.
- During maintenance or repair work, the trailer may be disconnected from the tractor, but secured by means of wedges and parking brake.
- Should it be necessary to replace individual parts, use only parts

recommended by the manufacturer. Failure to comply with these requirements may endanger the health or life of bystanders or persons operating the trailer, cause damage to the machine and constitute the basis for loss of warranty.

- Before welding or electrical work, the trailer should be disconnected from the power supply. The paint coating should be cleaned. The fumes of burning paint are poisonous to humans and animals. Welding work should be carried out in a well-lit and ventilated room.
- During welding work pay attention to flammable or fusible elements

(elements of pneumatic, electrical, hydraulic systems, elements made of plastic). If there is a risk of ignition or damage, they must be removed or covered with non-flammable material before welding. Before starting work, it is recommended to prepare a CO₂ or foam extinguisher .

- In the event of work requiring the trailer to be raised, use properly certified hydraulic or mechanical lifts for this purpose. After lifting the machine use stable and durable supports. It is forbidden to work under a trailer raised only with a jack.
- It is forbidden to support the trailer with fragile elements (bricks, hollow

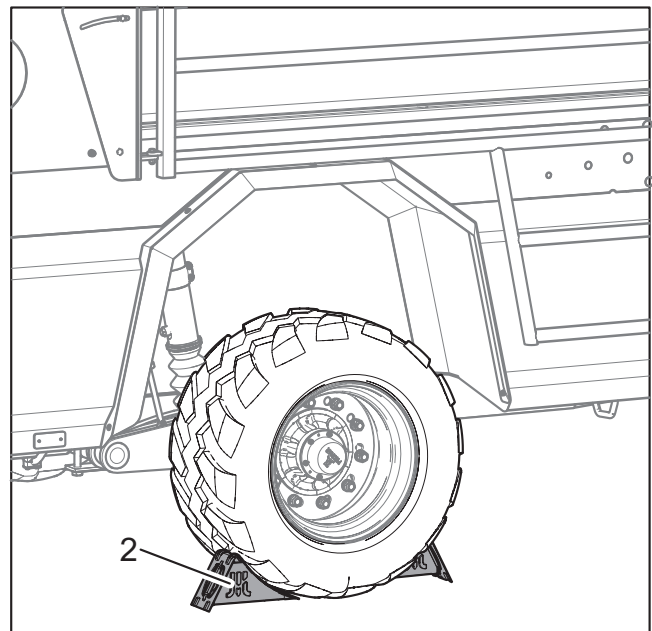
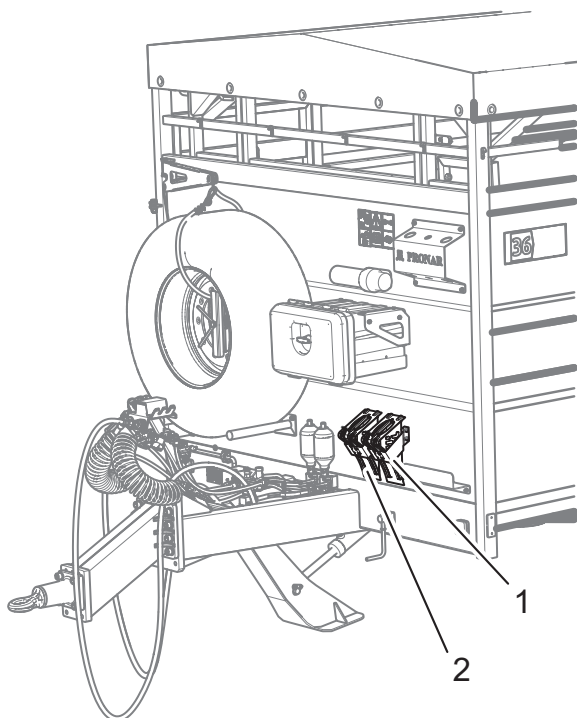

614-F.01-1

Figure 2.1 Laying the locking wedges
(1) wedge, (2) wedge pocket

bricks, concrete blocks).

- After completing work associated with lubrication, remove excess grease or oil. The trailer should be kept clean.
- It is forbidden to carry out independent repairs of hydraulic or pneumatic system components, i.e. control valves, actuators and regulators. In case of damage to these elements, the repair should be entrusted to authorized repair centres or replace the elements with new ones.
- It is forbidden to install additional devices or accessories that do not comply with the specification specified by the Manufacturer.
- The trailer may only be towed if the running gear, lighting and braking systems are functional.

F.3.4.622.06.1.EN

2.6 RULES TO MOVE ON PUBLIC ROADS

- Place a triangular sign for slow moving vehicles in the rear wall (if the trailer is the last vehicle in the set);
- Before driving on roads, remove the rear lamp covers.
- When driving on public roads, comply with traffic regulations and transport regulations in force in the country where the trailer is used.
- The maximum design speed of 40 km/h should not be exceeded. The travel speed must be adapted to the ambient conditions and the load. If possible, avoid driving over uneven terrain and unexpected turns.
- It is forbidden to leave the machine unsecured. The trailer disconnected from the tractor must be immobilized with the parking brake and secured against rolling with wedges or other elements without sharp edges placed under the vehicle wheel. (Figure 2.1) Wedges should only be placed under one wheel (one in front of the wheel, the other in the back).
- Before driving, make sure that the trailer is correctly connected to the tractor, especially that the hitch pins are secured.
- The vertical load carried by the trailer drawbar eye affects the steering of the agricultural tractor.
- Before using the trailer always check its technical condition, especially in terms of safety. In particular, check the technical condition of the hitch system, the running gear, the braking system and traffic lights as well as the connecting elements of the hydraulic, pneumatic and electrical systems.
- Before driving, check that the parking brake is released and the braking force regulator is in the correct position (applies to pneumatic systems with a manual three-position regulator).
- The trailer is adapted for driving on slopes up to a maximum of 8°. Moving the trailer over slopes may cause the trailer to overturn as a result of loss of stability.
- When driving on public roads, the tractor operator must ensure that the trailer and tractor are equipped with an approved or homologated warning reflective triangle.
- Periodically drain the air tank in the pneumatic system. During frosts, freezing water may cause damage to pneumatic system components.
- Reckless driving and excessive

- speed can cause accidents.
- Load protruding beyond the outline of the trailer should be marked in accordance with traffic regulations. It is forbidden to transport loads not allowed by the manufacturer.
 - The trailer's maximum carrying capacity must not be exceeded. Exceeding the carrying capacity may lead to damage to the machine, loss of stability and a hazard while driving. The braking system of the machine has been adapted to the total weight of the trailer, exceeding of which will drastically reduce the operation of the service brake.
 - Prolonged travel over sloping ground creates a risk of loss of braking performance.
 - When reversing, it is recommended to use the help of another person. During maneuvers, the helping person must keep a safe distance from danger zones and be visible to the tractor operator at all times.
 - It is forbidden to get on the trailer while driving.
 - Parking the trailer on a decline is prohibited.
 - Never drive if the trailer is even partly lowered.

F.3.9.614.07.1.EN

2.7 TIRES

- When working with tires, the trailer should be immobilized with the parking brake and secured against rolling by placing chocks under the wheels. The wheel can be dismantled only when the trailer is not loaded.
- Repair work on wheels or tires should be carried out by persons trained and authorized to do so. These works should be carried out using appropriately selected tools.
- Inspection of nut tightening should be carried out after the first use of the trailer, after the first journey with a load and then every 6 months of use, or every 25,000 km. In the case of intensive work,
- tightening control should be carried out at least once every 100 kilometers.
- Each time, the inspection activities should be repeated if the trailer wheel has been disassembled.
- Avoid damaged road surfaces, sudden and variable maneuvers, and high speeds when turning.
- Check tire pressure regularly. Tire pressure should also be checked during all-day intensive work. It should be taken into account that an increase in tire temperature can increase the pressure by up to 1 bar. With such a rise in temperature and pressure, reduce the load or speed. Never reduce pressure by venting if it increases due to temperature.
- Protect tire valves with caps to avoid penetration of dirt
- .

F.3.9.614.08.1.EN

2.8 DESCRIPTION OF RESIDUAL RISK

- Pronar Sp. z o. o. in Narew made every effort to eliminate the risk of an accident. However, there is some residual risk that can lead to an accident and is primarily associated with the following activities:
- using the trailer for purposes other than described in the manual,
- being between the tractor and the trailer during engine operation and when connecting the machine,
- trailer operation by persons under the influence of alcohol or drugs,
- trailer operation by unauthorized persons,
- being on the machine during work,
- cleaning, maintenance and technical

inspection of the trailer.

Residual risk can be reduced to a minimum by following these recommendations:

- prudent and leisurely machine operation,
- sensible application of the notes contained in the User Manual,
- maintaining a safe distance from prohibited and dangerous places,
- a ban on being on the machine during its work,
- carrying out maintenance and repair work by trained persons,
- using appropriate protective clothing,
- securing the machine against access by unauthorized persons, especially children.

F.3.9.614.10.1.EN

2.9 INFORMATION AND WARNING STICKERS

The trailer is marked with information and warning decals mentioned in table (2.1). Arrangement of symbols is shown in Figure (2.2). The machine user is obliged to ensure that the inscriptions, warning and information symbols placed on the trailer are legible throughout the entire period of use.

In the event of their destruction, they must be replaced. Information and warning stickers can be purchased directly from the Manufacturer or in the place where the



machine was purchased.







The catalogue numbers of the labels can be found in the table (2.1) and in *Spare parts catalogue*. New assemblies replaced during repair must be marked again with the appropriate safety signs. When cleaning the screen, do not use solvents that may damage the label coating and do not direct a strong water jet.

Other information stickers, located on the system connection cables are presented in chapter 4.

F.3.9.614.11.1.EN

Table 2.1. Information and warning stickers

Item	Sticker	Meaning
1		Lubricate the machine according to the schedule included in the USER MANUAL. 104N-00000004
2		Regularly check the tightness of wheel nuts and other bolted connections. 104N-00000006
3		Crushing your fingers or hands - Force applied from above 204N-00000004

Item	Sticker	Meaning
4		<p>Permissible design speed 204N-00000008</p>
5		<p>Guarantee period 589N-00000003</p>
6		<p>Company marking 614N-00000001</p>
7		<p>Marking of the machine on the left - machine type 614N-00000003</p>
8		<p>Marking of the machine - right side - machine type 614N-00000004</p>
9		<p>Before use read the operating instructions 70N-00000004</p>
10		<p>Before starting servicing or repair work, switch off tractor engine and remove keys from ignition. 70N-00000005</p>

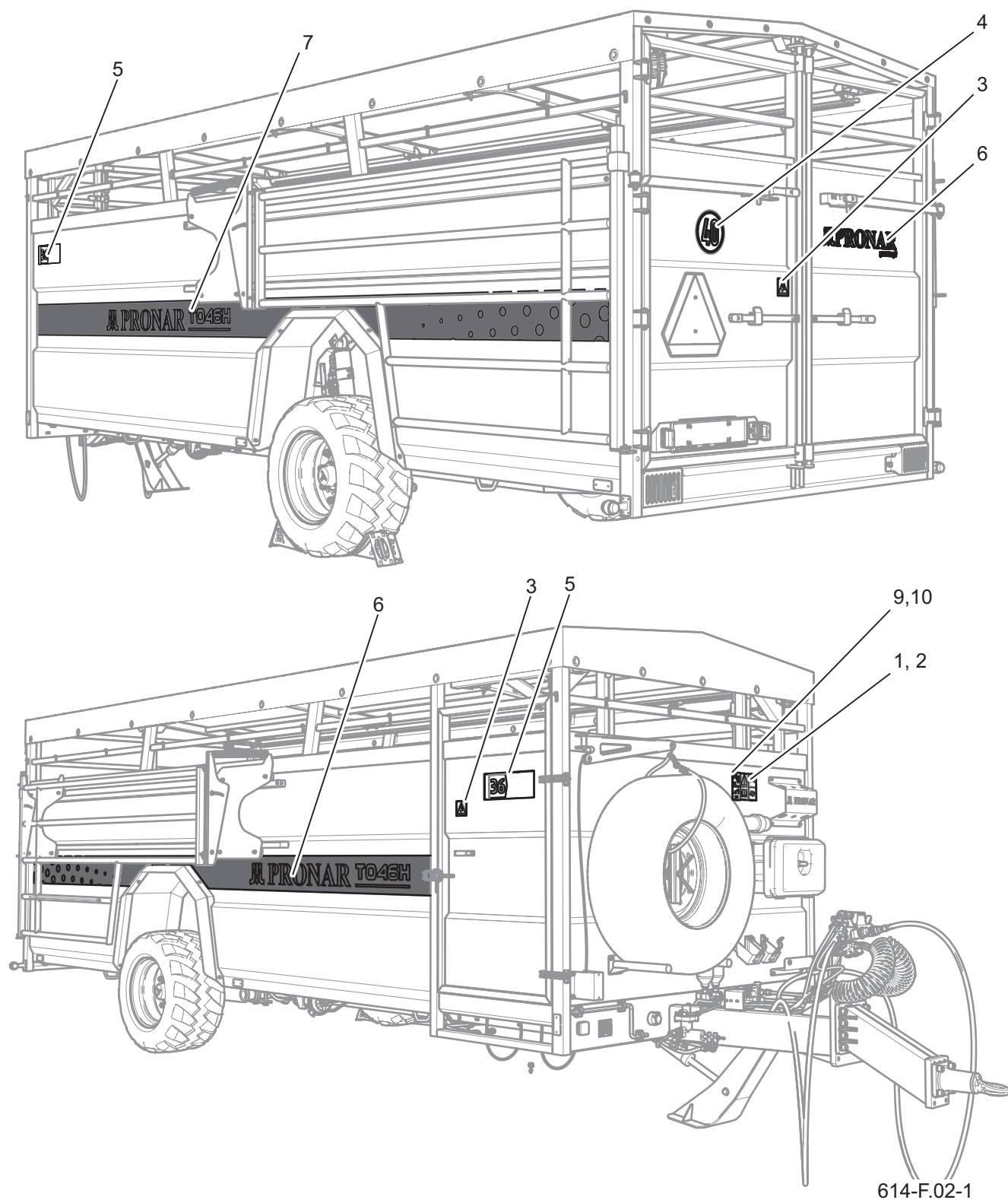

Figure 2.2 Arrangement of information and warning stickers

CHAPTER 3

CONSTRUCTION AND OPERATION

3.1 TECHNICAL CHARACTERISTICS

Table 3.1. Basic technical data

Content	Unit	T046H
Dimensions		
Length	[mm]	8,320
Width	[mm]	2,550
Height	[mm]	2,860
Loading box dimensions:		
Length	[mm]	6,280
Width	[mm]	2,240
Height of loading box inside	[mm]	2,100
Weight and load capacity		
Capacity	kg	7,825 ¹⁾
Curb weight	kg	3,175
Permissible gross weight	kg	11,000
Other information		
Wheel track	[mm]	2,163
Platform height from the ground	[mm]	700
Tractor power demand	KM (kW)	41.6 (30.6)
Permissible design speed	km/h	40
Electrical system voltage	V	12
Drawbar eye load	kg	2000
Sound power level	dB	below 70
Loading area	m ²	13.2 ²⁾

Tire information is provided at the end of the publication in ANNEX A.

¹⁾Area and load capacity of the trailer adapted to: 8 pcs. of very heavy cattle (700kg) or 10 pcs. heavy cattle (550kg) max. 11 LSU - Livestock unit);

²⁾The area without the wheel arch;

3.2 GENERAL CONSTRUCTION

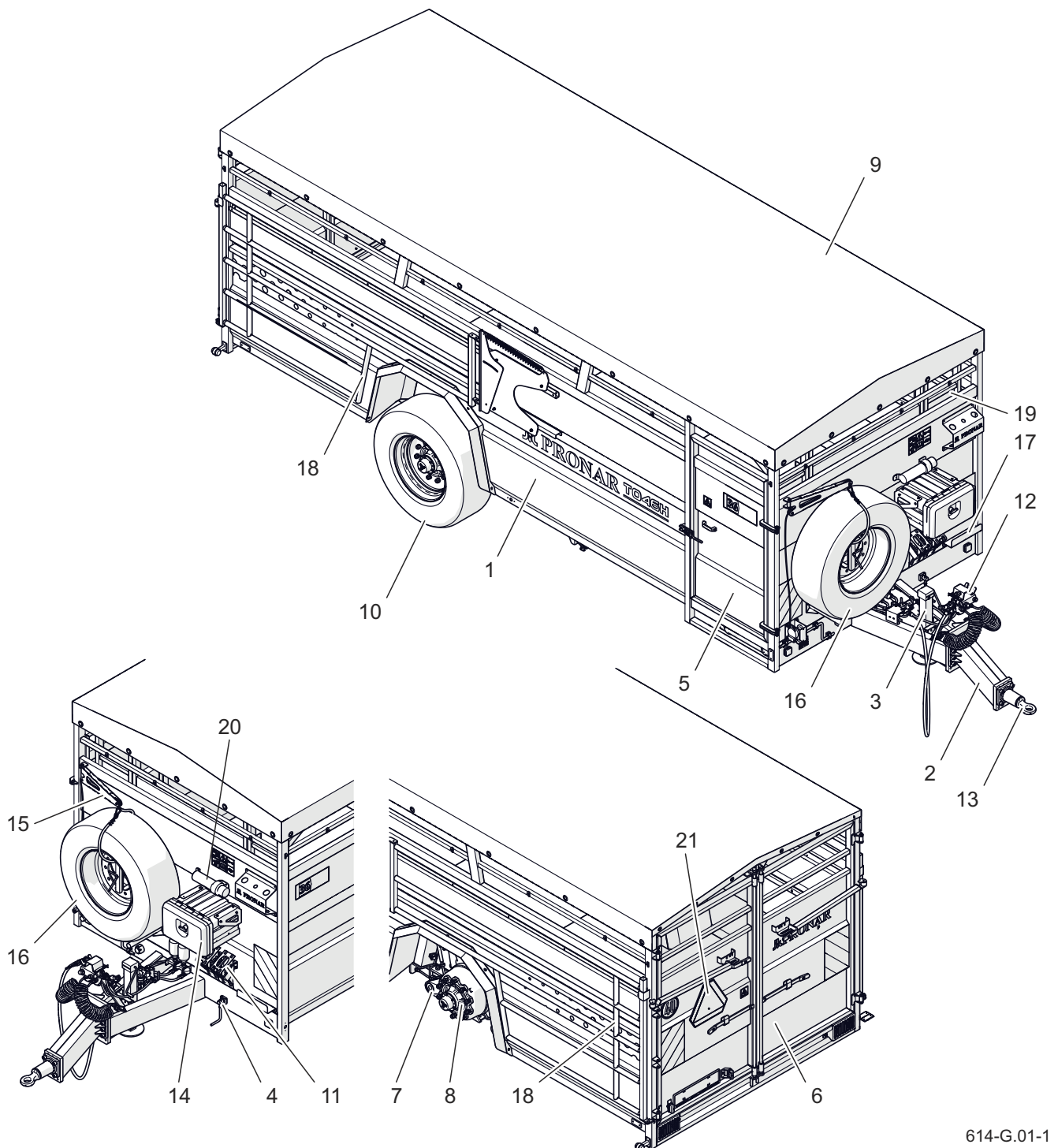

614-G.01-1

Figure 3.1 General construction

(1) load box (2) drawbar (3) straight mechanical support (4) handbrake mechanism (5) side door (6) rear door (7) suspension (8) drive shaft (9) tarpaulin (10) wheel (11) wheel chocks (12) cable support (13) cable (14) tool box (15) spare wheel attachment (16) spare wheel (17) tool support (18) railings (19) partition (20) document tube (21) distinguishing table

3.3 SERVICE BRAKE

The trailer is equipped with one of three types of service brake installation:

- double conduit pneumatic system with manual braking force regulator - figure (3.2),
- double conduit pneumatic system with automatic braking force regulator (ALB) - figure (3.3),
- hydraulic system - figure (3.4).

The service brake is activated from the driver's cab by pressing the tractor brake pedal. The task of the used control valve (1) - figure (3.5) in pneumatic systems is to

activate the trailer's brakes simultaneously with the tractor's brake on. In addition, in the event of an unforeseen disconnection of the conduit between the trailer and the tractor, the control valve automatically applies the machine's brake. The used valve has a brake release system, used when the trailer is disconnected from the tractor. After connecting the air line to the tractor, the release device automatically adjusts to the position enabling normal operation of the brakes.

The three-range braking force regulator

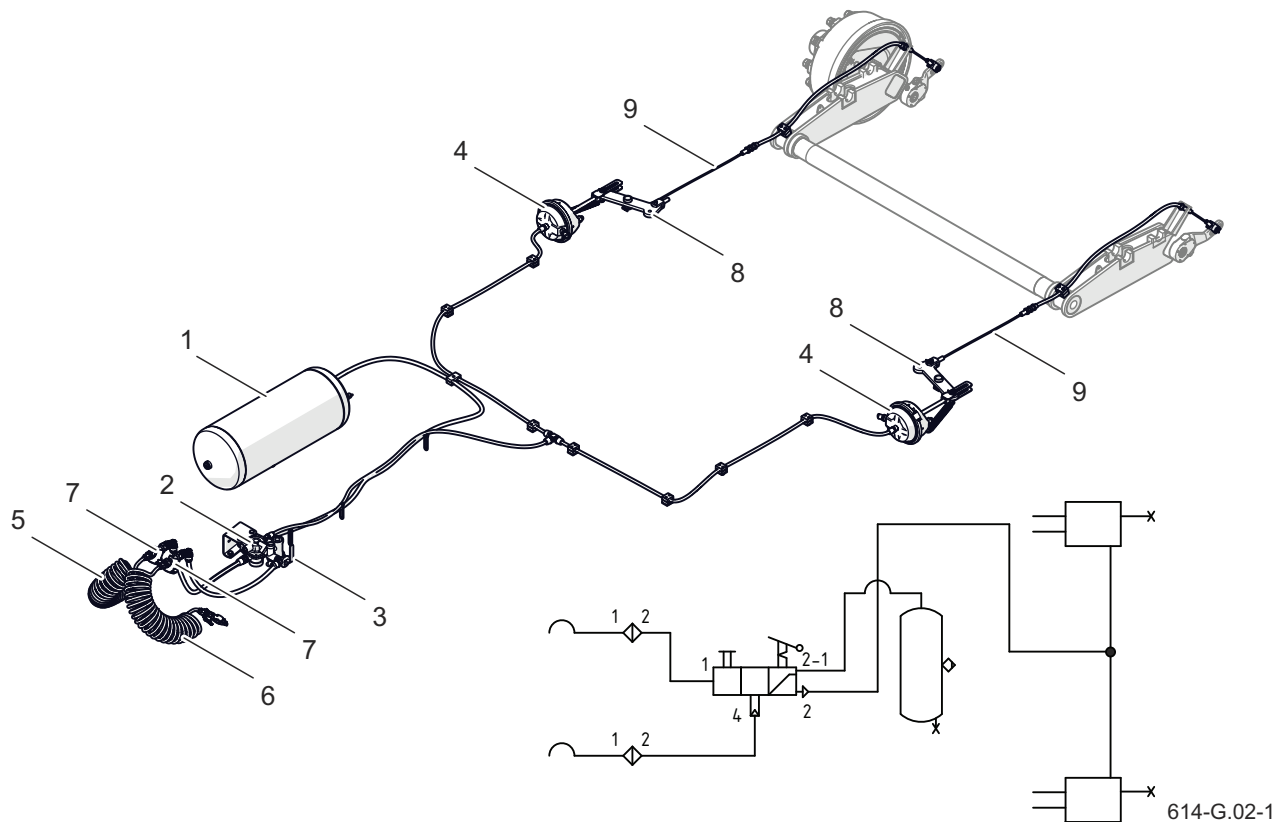

Figure 3.2 Construction and diagram of the dual-line pneumatic braking system with a manual braking force regulator

(1) air tank (2) control valve (3) braking force regulator (4) pneumatic cylinder (5) red spiral hose (6) yellow spiral hose (7) air filter (8) lever (9) cable

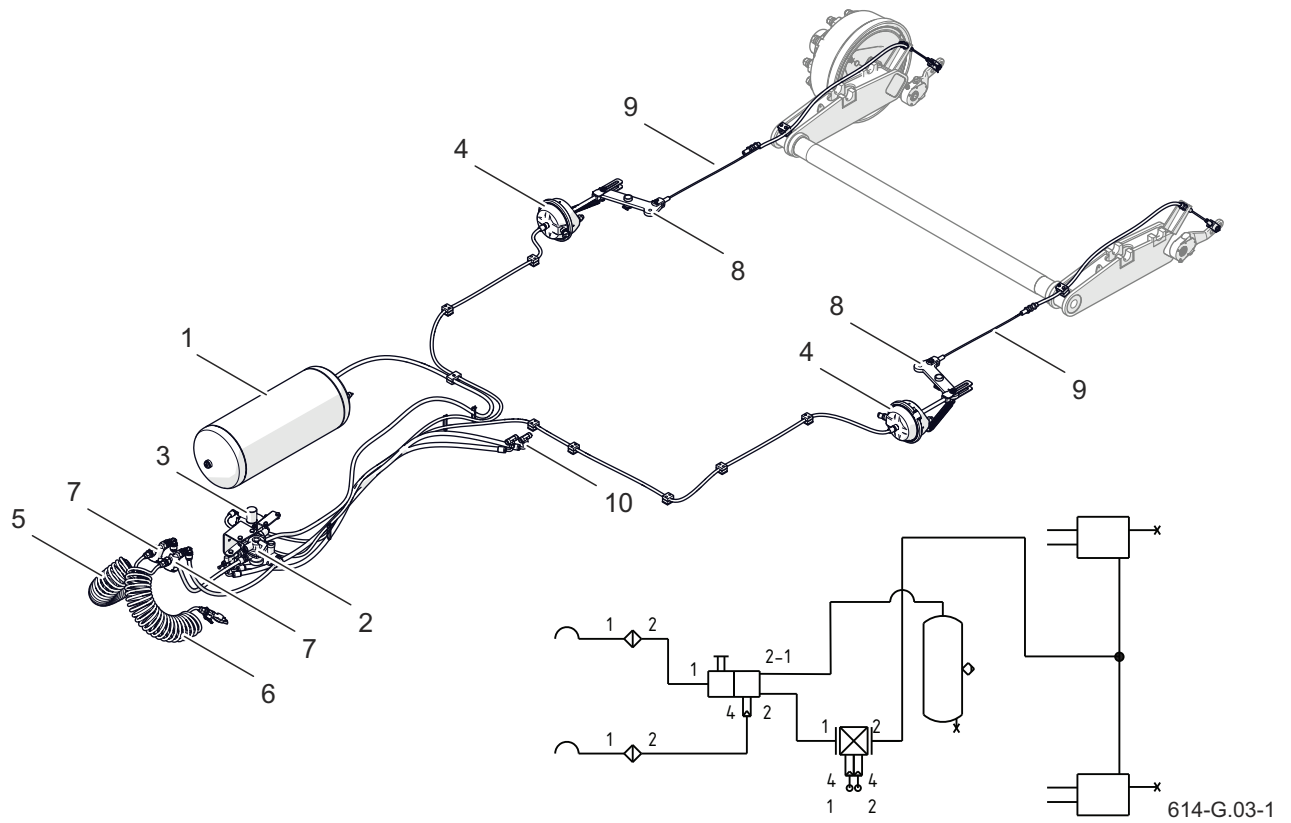

Figure 3.3 Construction and diagram of the dual-line pneumatic braking system with an automatic braking force regulator

(1) air tank (2) control valve (3) braking force regulator (4) pneumatic cylinder (5) red spiral hose (6) yellow spiral hose (7) air filter (8) lever (9) cable (10) reducing tee

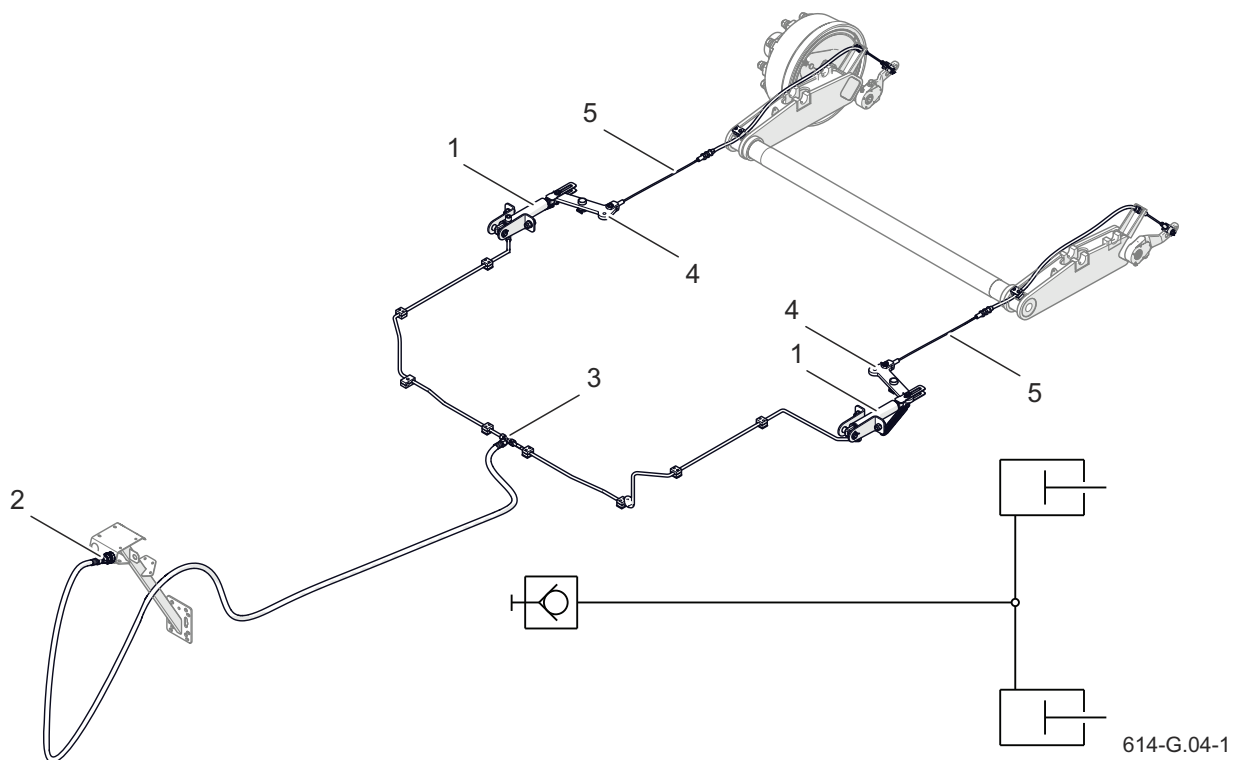
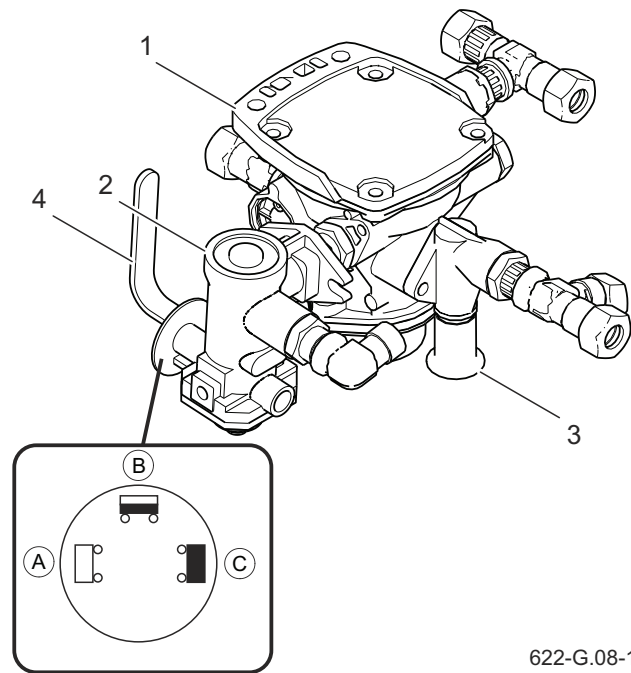

Figure 3.4 Construction and diagram of hydraulic braking system

(1) hydraulic cylinder (2) quick coupler (3) tee (4) lever (5) cable

(2) used in pneumatic systems adjusts the braking force depending on the setting. Switching to the appropriate operating mode is done manually by the machine operator before starting the journey using the lever (4). There are available three work positions: A - 'No load', B - 'Half load' and C - 'Full load'.



622-G.08-1

Figure 3.5 Control valve and braking force regulator

(1) control valve (2) brake force regulator (3) brake release button (4) setting lever

(A) 'NO LOAD' position

(B) 'HALF LOAD' position

(C) 'FULL LOAD' position

G.3.9.614.03.1.PL

3.4 PARKING BRAKE

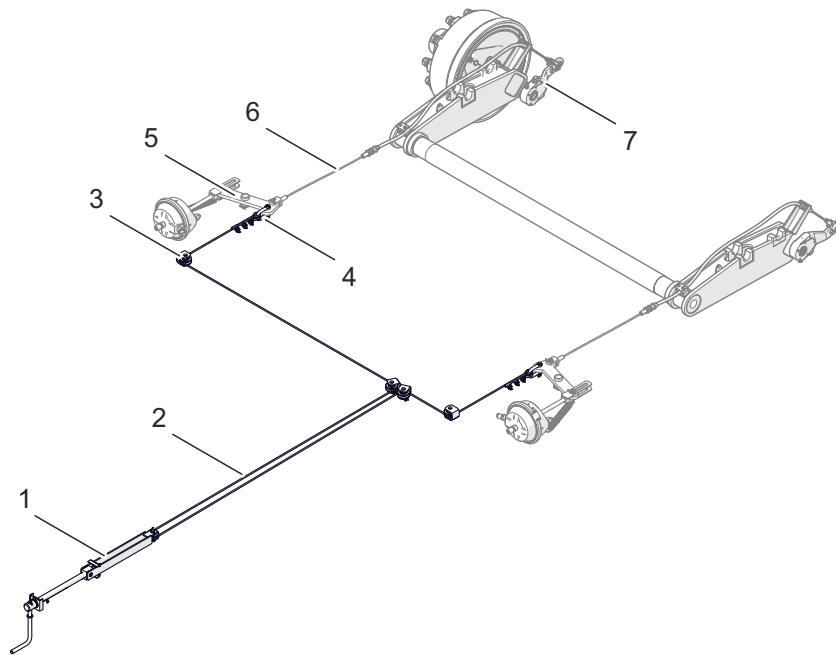

614-G.05-1

Figure 3.6 Parking brake

(1) crank mechanism (2) steel cable (3) roller (4) screw shackle (5) lever (6) cable (7) extender lever

The parking brake is used to immobilize the trailer during parking.

The crank mechanism (1) located on the front beam of the trailer box is connected with a steel cable (2) to the levers (5). The cables (6) connect the levers (5)

with the expander levers (7) of the drive shafts. Tensioning of the cables (turning the crank of the mechanism clockwise) causes swinging of the expander levers, which, turning, open the brake shoes and immobilize the trailer during parking.

G.3.9.614.04.1.PL

3.5 THE HYDRAULIC SYSTEM OF SUSPENSION

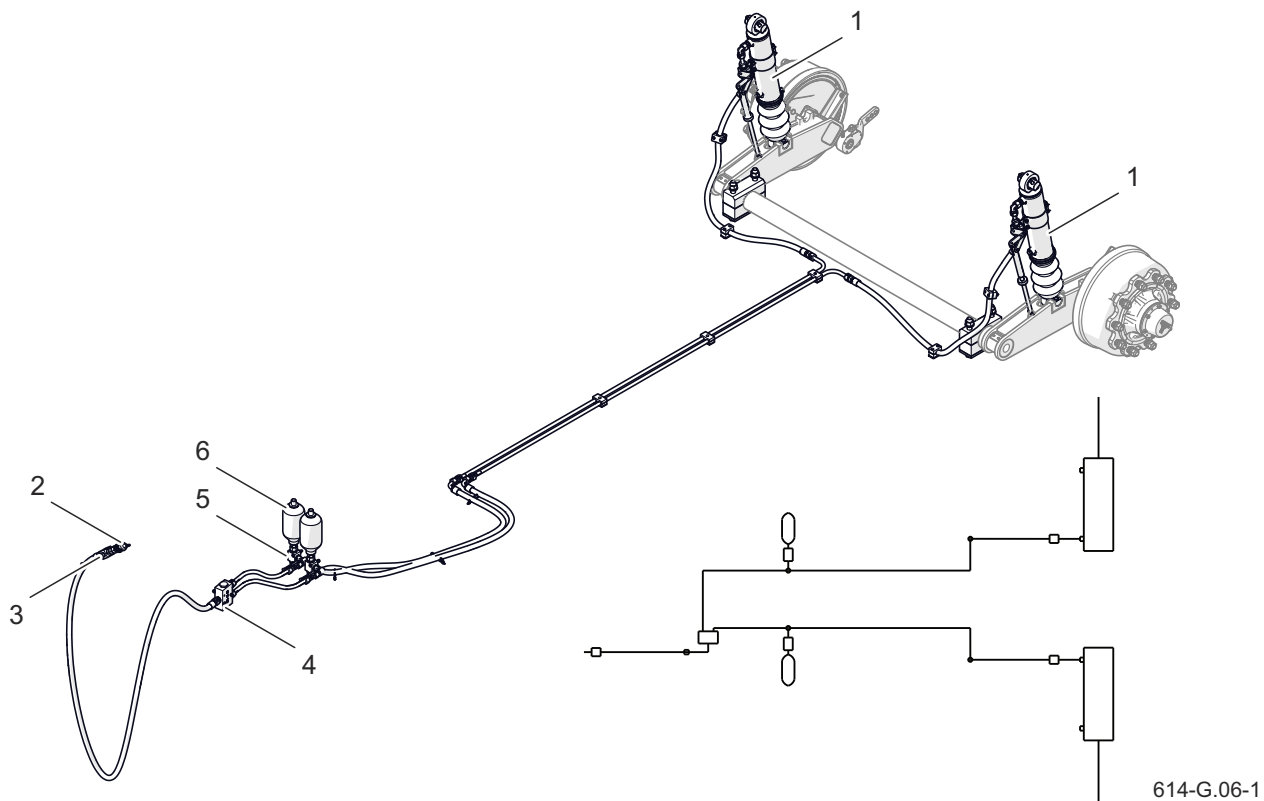

Figure 3.7 Construction and diagram of the hydraulic system of lowering the suspension (1) hydraulic cylinder (2) quick coupler (3) hydraulic valve (4) flow divider (5) hydraulic valve (6) hydraulic accumulator

The hydraulic trailer suspension system is used to lower and raise the trailer while loading animals.

The hydraulic system is supplied with oil from the tractor's external hydraulic system. The circuit is controlled from the tractor cabin using the appropriate hydraulic lever.

The suspension hydraulic system consists of two hydraulic cylinders (1) acting as spring elements. Two hydraulic accumulators (6) are installed in the system

circuits, whose task is to dampen suspension vibrations while driving.

The hydraulic valves (5) are used to lock the hydraulic cylinders during maintenance and repair work.



CAUTION

Before each use of the trailer, check the condition of hydraulic system hoses. In the event of damage or wear, replace them immediately.
Never drive if the trailer is even partly lowered.

G.3.9.614.05.1.PL

3.6 ELECTRICAL SYSTEM, WARNING ELEMENTS

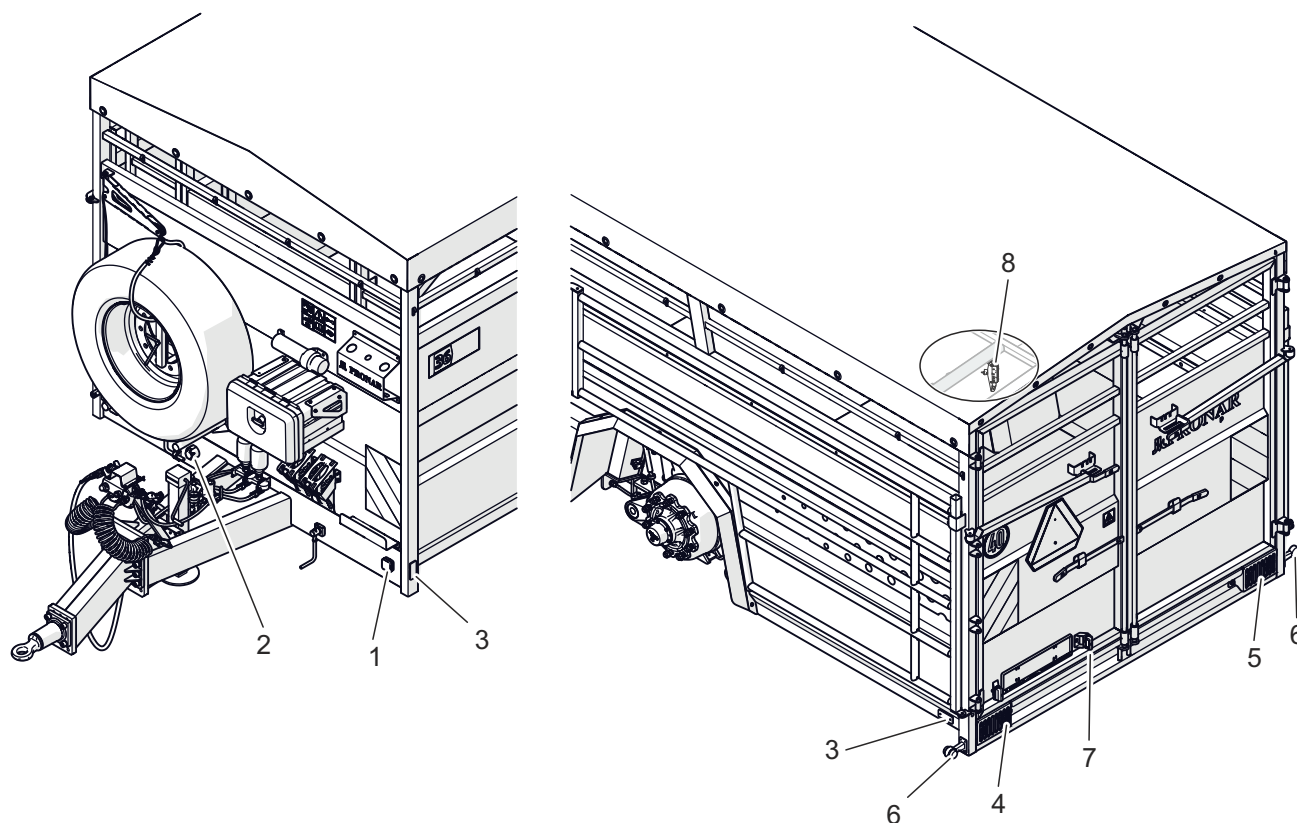

614-G.07-1

Figure 3.8 Arrangement of electric and reflective elements

(1) front position lamp (2) 7-pin front socket (3) side position lamp (4) rear left composite lamp (5) rear right composite lamp (6) rear clearance lamp (7) license plate lamp (8) LED work lamp

The trailer's electrical system is adapted to be supplied from a 12 V DC source. The trailer's electrical installation should be connected with the tractor with the appropriate connection cable, which is included in the machine's equipment. The arrangement of electrical components of the lighting installation is shown in figure (3.8).

Table 3.2. Colour coding of wires

Mark	Function
B	White
C	Black
K	Red
T	Green
O	Brown
Z	Yellow

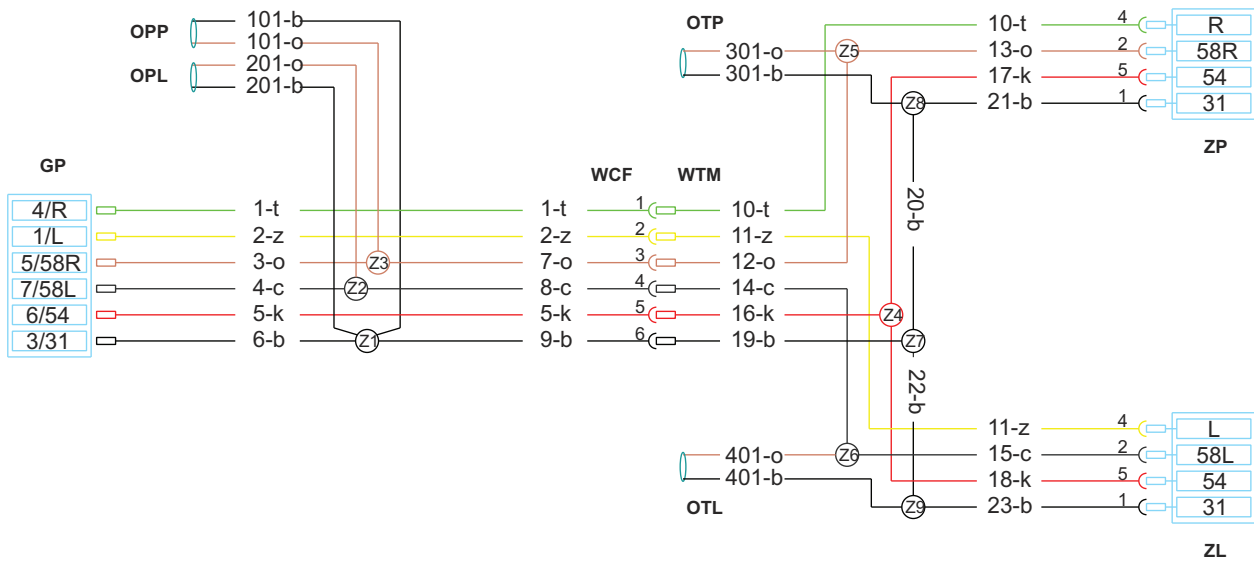

614-G.08-1

Figure 3.9 Schematic diagram of the electrical system

Designations according to tables (3.2) and (3.3)

Table 3.3. Designation of electrical components

Symbol	Function
PP	Right front position lamp
PL	Left front position lamp
ZP	Multifunctional rear right lamp
ZL	Multifunctional rear left lamp
OT	Plate light
TOP	Front-rear clearance lamp and right position lamp
TOL	Front-rear clearance lamp and left position lamp
OBP	Right clearance lamp
OBL	Left clearance lamp
GP	Front 7-pin socket



CAUTION

Machine lamps work only when the trailer is connected to the agricultural tractor and the position lights are on.

G.3.9.614.06.1.PL

CHAPTER 4

TERMS OF USE

4.1 OPERATION OF EQUIPMENT/COMPONENTS

HYDRAULIC SUPPORT

The construction of the hydraulic system is shown in figure (4.1). The support foot (4) is extended and folded by means of a hydraulic cylinder (1), which is controlled by means of the tractor's external hydraulic system. The shut-off valve (2) is used to close the oil supply to the cylinder when the trailer is stationary and while driving when the support is folded into transport position. The valve position (open/closed) is marked with the help of an information sticker (3) in the Z position - closed.



DANGER

Be careful because of the risk of feet crushing.

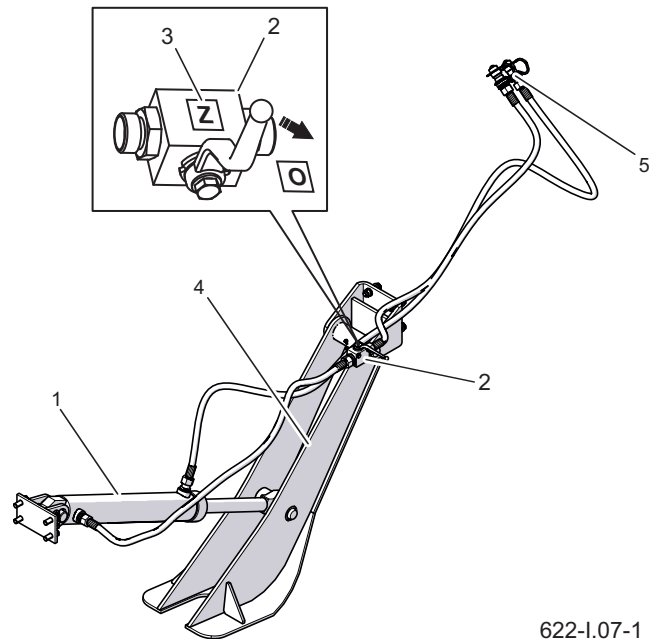

622-1.07-1

Figure 4.1 Hydraulic support
 (1) hydraulic cylinder, (2) shut-off valve, (3) information sticker, (4) support foot, (5) hydraulic plug,

H.3.4.622.01.1.PL

4.2 CONNECTING AND DISCONNECTING THE TRAILER

CONNECTING A TRAILER



CAUTION

After connecting the trailer, perform a daily inspection of the machine before travelling.
The external examination of the machine without connecting it to the tractor will not allow verification of its technical condition.
Detailed information on inspections can be found in chapter 5.

The trailer may be connected to an agricultural tractor if all connections (electrical, pneumatic, hydraulic) in the agricultural tractor are in accordance with the trailer manufacturer's requirements given in the table *Requirements of the agricultural tractor*.

BEFORE USE

- Make sure the trailer is immobilized with the parking brake.

Turn the brake mechanism clockwise as far as it will go - figure (4.2).

- Make sure that blocking wedges are placed under the trailer wheel - figure (4.3).
- Position the agricultural tractor directly in front of the drawbar eye.

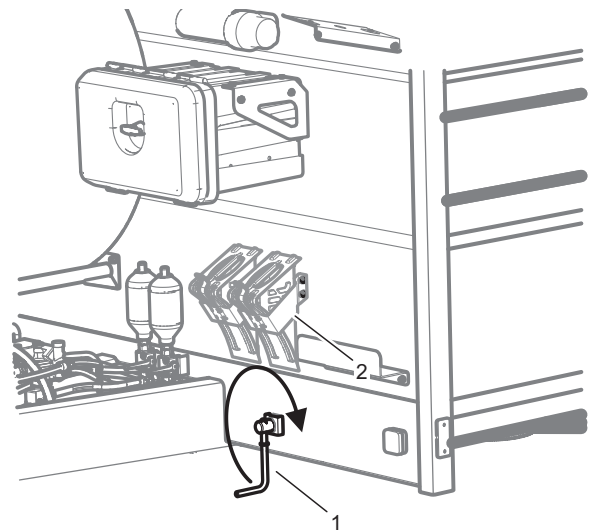

614-H.07-1

Figure 4.2 Parking brake
(1) brake mechanism (2) wedge pocket

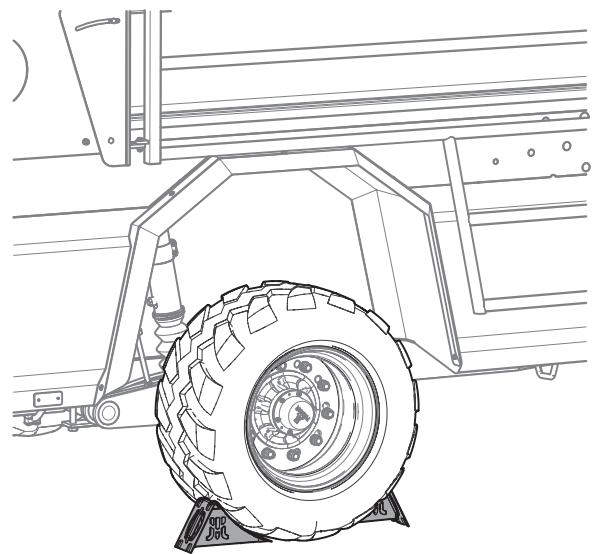

614-F.06-1

Figure 4.3 Locking wedges

HEIGHT ADJUSTMENT OF THE TRAILER'S DRAWBAR



DANGER

During coupling it is forbidden to stand bystanders between the trailer and the tractor. The agricultural tractor operator when connecting the machine should make sure that bystanders are not in the danger zone during coupling.

Take care when connecting the trailer.

Ensure good visibility during coupling.

After completing the coupling, check the pin hitch safety.

- If the trailer is equipped with a hydraulic support, first connect the hydraulic system conduit marked with a sticker (1) - figure (4.4). Then proceed in accordance with the chapter *Hydraulic support*.
- In the event that the trailer is equipped with a parking support with mechanical transmission, the adjustment is carried out using the support transmission - see *Mechanical support*.

CONNECTING THE TRAILER TO THE TRACTOR'S HITCH

- Reverse the tractor and connect the trailer to the appropriate hitch.
- Check the coupling safety device protecting the machine against accidental disconnection.
- If an automatic coupling is used in

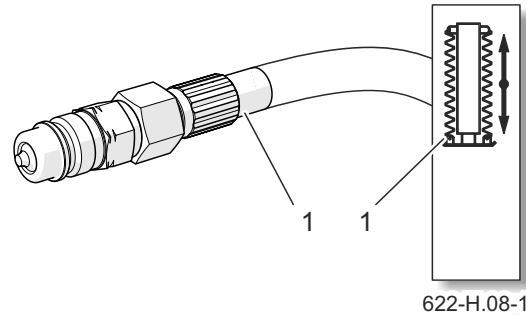

Figure 4.4 Hydraulic connection of the support

(1) *information sticker*

the tractor, make sure that the aggregation operation is completed and the drawbar eye is secured.

- Move the parking stand to transport position.
- Switch off the tractor engine and remove the ignition key. Secure the tractor with the parking brake. Close the tractor cabin and secure it against unauthorized access.

CONNECTING THE BRAKING SYSTEM

- Depending on the trailer configuration, connect the braking system connectors to the appropriate tractor sockets.
- Connect pneumatic system lines.

First, connect the yellow plug to the yellow socket on the tractor, and then the red plug to the red socket on the tractor. After connecting the second conduit, the brake release system will switch

to normal operation mode (disconnection or interruption of the air conduits causes the trailer control valve to automatically move to the machine braking position).

- If the brakes do not react after connecting the pneumatic hoses, this may indicate a low pressure in the tank. For the system to work, it must be filled with the correct pressure.
- Connect the hydraulic braking system conduit (applies to trailer version with hydraulic braking system).

CONNECTING OF THE HYDRAULIC SYSTEM

Depending on the trailer configuration, connect the hydraulic system connectors to the appropriate tractor sockets.

Connect hydraulic braking system hoses (applies to trailer version with hydraulic braking system).

- The hydraulic brake system hose is marked with an information sticker (3) - figure 4.5.
- Connect the hydraulic hoses of the suspension.
- The supply line of the suspension hydraulic system has a shut-off valve

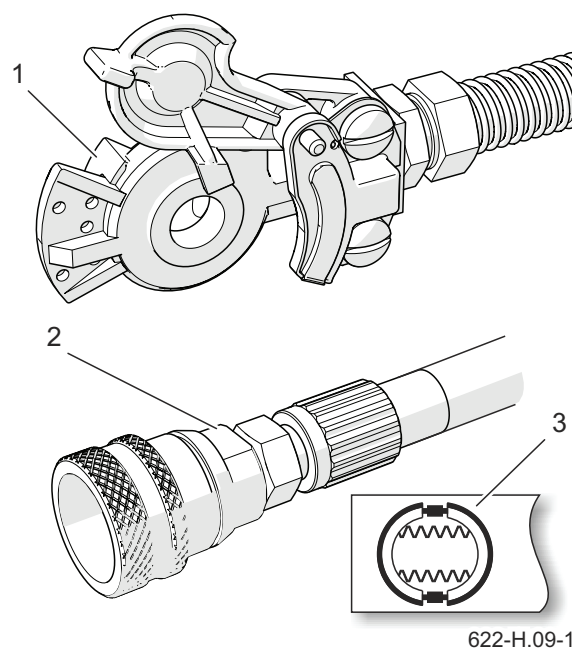

Figure 4.5 Brake system connections

- (1) pneumatic plug (red, yellow)
(2) hydraulic plug (3) sticker



CAUTION

When connecting pneumatic conduits of a double conduit system, first connect the conduit marked yellow and then the conduit marked red.

CONNECTING THE LIGHTING ELECTRICAL INSTALLATION

- Connect the main cable (1) supplying the lighting electrical installation (7-pin).

If the tractor does not have such sockets or the sockets are of a different type, then installation should be carried out by a qualified person in accordance with the recommendations of the tractor manufacturer.

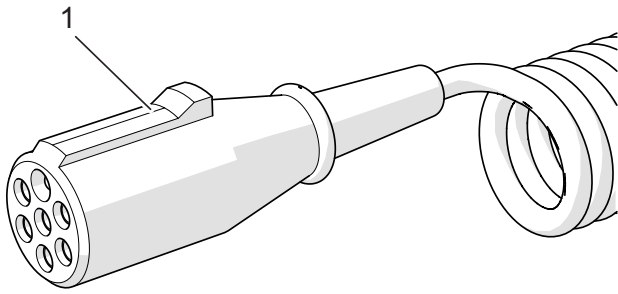

622-H.10-1

Figure 4.6 Electrical connection
(1) 7-pin cable

ADDITIONAL INFORMATION

- After completing the connection of the hoses, make sure that they do not get caught in the moving parts of the tractor or trailer during operation. Secure the cables as necessary.
- Perform a daily inspection of the trailer.
- If the trailer is functional, you can start working.
- Immediately before driving, remove the wheel chocks and release the machine parking brake.

Turn the crank handle anti-clockwise as far as it will go.

DISCONNECTING A TRAILER

- Place the trailer on a hard and flat surface.
- Lower the support to parking position.
- Switch off the tractor engine and

remove the ignition key, secure the tractor with the parking brake.

- Immobilize the trailer with parking brake.
- Place blocking wedges under one wheel of the trailer, one in the rear and the other in front of the wheel.
- Disconnect all cables in turn. Secure the ends by fitting the rubber caps on the hydraulic connectors.
- Place the cables on the cable support (12) - figure (3.1).
- Release the drawbar eye, start the tractor and drive away with the tractor.



CAUTION

After completing the coupling, secure the hydraulic, braking and electrical wiring in such a way that they do not become entangled in the moving parts of the agricultural tractor during travel and are not exposed to kinking or cutting during turning.



CAUTION

In the event of a longer standstill of the trailer, it may turn out that the air pressure in the pneumatic braking system is insufficient to release the brake shoes. In this case, after starting the tractor and the air compressor, wait until the air in the pneumatic tank is topped up.



DANGER

The use of defective trailers is forbidden.

**CAUTION**

When disconnecting the pneumatic conduits of a dual conduit, first disconnect the conduit marked red and only then the conduit marked yellow.

It is forbidden to park the trailer with the container loaded, disconnected from the tractor and supported by the support.

It is forbidden to disconnect the trailer from the tractor if the swing frame or middle frame are not folded and when the suspension lock cylinders are extended.

**DANGER**

When disconnecting the trailer from the tractor, take particular care.

Ensure good visibility. Unless it is necessary, do not stay between the trailer and the tractor.

Before disconnecting cables and drawbar eye, close tractor cab and secure it against unauthorized access. The tractor engine must be turned off.

H.3.4.622.02.1.PL

4.3 HYDRAULIC SYSTEM OPERATION

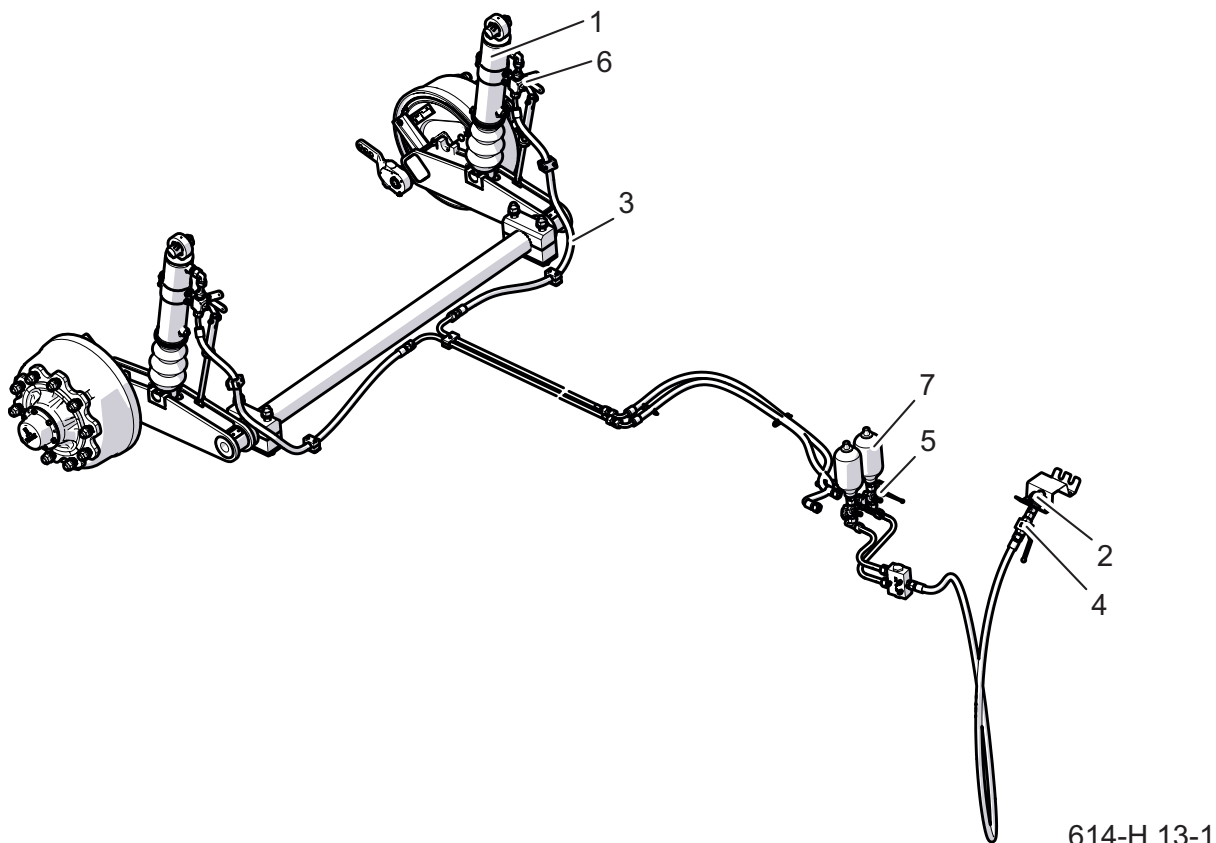

Figure 4.7 The hydraulic system of suspension
 (1) cylinder (2) hydraulic connector (3) hydraulic system lines
 (4) shut-off valve (5) hydro-accumulator valves (6) shut-off valve

The hydraulic trailer suspension system T046H is used to lower and raise the trailer while loading animals. The hydraulic system is supplied with oil from the tractor's external hydraulic system. The circuit is controlled from the tractor cabin using the appropriate hydraulic lever.

The suspension hydraulic system consists of two suspension hydraulic cylinders (1) acting as spring elements. The cylinders are connected to each other by means of hydraulic hoses (3). Two hydraulic



DANGER

The hydraulic system is under high pressure. In order to carry out repairs, block the hydro-accumulators, block the valves (5) in the closed position (z).

accumulators (7) are installed in the system circuits to suppress suspension vibrations while driving.

The hydraulic valve (4) is used to lock the hydraulic cylinders during maintenance and repair work.

H.3.4.622.04.1.PL

4.4 LOADING

During loading the trailer must be connected to the tractor. It is recommended to place the trailer on a stable, flat surface and block the vehicle by placing wedges under the wheels and applying the hand-brake. Animals to be transported should be arranged as regularly as possible on the entire surface of the trailer

REAR DOOR OPENING



CAUTION

It is forbidden to exceed the trailer's maximum carrying capacity as it threatens road safety and may cause damage to the trailer.

To open the rear door, raise the bolt arm (A), then turn the bolt to unlock the locking hooks. The door should open easily. After opening the door, secure it against accidental closing with a lock.

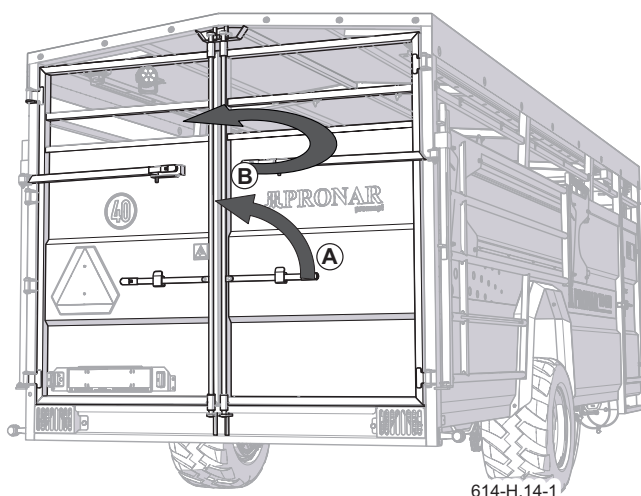

Figure 4.8 Rear door opening

HYDRAULIC LOWERING OF THE TRAILER

Before lowering the trailer, make sure that the cables are connected

the hydraulic suspension controls are correctly connected to the tractor's hydraulic system. Slowly set the hydraulic valve (5) - figure (3.7) to the open position.

Before lowering, make sure that the operation is performed on a stable and flat surface, and pay special attention not to damage the rear door if it is open.

The lowering of the trailer is activated by means of a suitable hydraulic lever on the tractor.

USING SIDE RAILINGS

Side railings are attached to the outer wall of the trailer. To unfold the side gates (1), lower the trailer and unlock the cotter pin (2). Then remove the railing from the hanger (3) and unfold it sideways in the desired position.

Open the rear door so that it is as close as possible to the side railings.



DANGER

Before each use of the trailer, check the condition of hydraulic circuit hoses.

Before lowering the trailer make sure that there are no persons or animals behind the trailer or partially under the trailer.

After loading, carry out the operations in reverse order before transporting. Check the attachment and safety of the railings.

**CAUTION**

Before starting to travel, the operator must be sure that the rear door is well closed and locked, the railings are fixed at their original anchorages, tied animals and the trailer are fully raised.

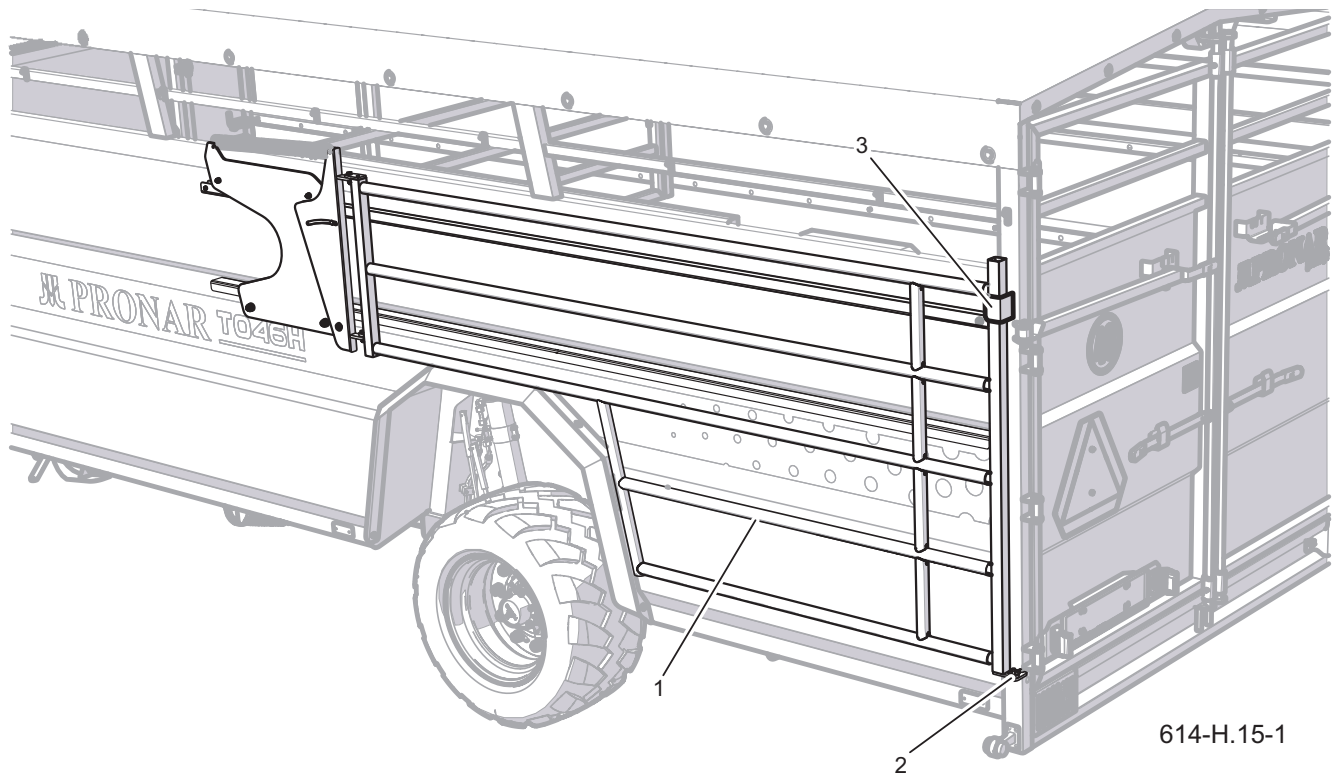

Figure 4.9 Side rails

(1) Side rails (2) Cotter pin (3) Rails hanger

H.3.9.614.07.1.PL

4.5 TRANSPORT OF ANIMALS

When driving with a trailer on the road, comply with traffic regulations, be prudent and considerate. Below are the most important guidelines for driving a tractor with an attached trailer for transporting animals.

- Before moving off make sure that there are no bystanders, especially children, near the trailer and tractor. Ensure proper visibility.
- Make sure that the trailer is correctly connected to the tractor and tractor's hitch is properly secured. All components of the trailer should be firmly attached (doors, railings, internal partition) and animals tied up.
- Transported animals should be provided with comfort and safety.
- The trailer must not be overloaded, the animals should be evenly distributed. Exceeding the maximum load capacity of the trailer is forbidden and may cause damage to the trailer, and may also constitute a danger during travelling on the road for the tractor and trailer operator or other road users.
- The permissible design speed and speed resulting from restrictions on road traffic regulations must not be exceeded. The travel speed should be adjusted to the prevailing road conditions, trailer load condition, type of load carried and other conditions.
- The trailer disconnected from the tractor must be secured by immobilizing it with the parking brake and placing chocks or other elements without sharp edges under the wheels. Leaving an unsecured trailer is prohibited.
- In the event of a trailer breakdown, stop at the side of the road without endangering other road users and mark the stopping place in accordance with traffic regulations.
- When travelling on public roads, the trailer must be marked with a slow-moving vehicle plate, located on the rear wall of the load box. The tractor operator is required to equip the trailer with an approved or approved warning reflective triangle. While driving, obey the rules of the road, signal a change of direction using direction indicators, keep clean and take care of the technical condition of the lighting and signalling system. Damaged or lost lighting and signalling components must be repaired or replaced immediately.

- Avoid ruts, depressions, ditches, or driving along roadside slopes. Driving across such obstacles can cause the trailer and tractor to tilt suddenly. This is particularly important because the centre of gravity of the laden trailer adversely affects driving safety. Driving near the edges of ditches or canals is dangerous due to the risk of landslides under the wheels of a trailer or tractor.
- The travel speed should be reduced sufficiently in advance of approaching bends, when driving on uneven or sloping terrain.
- When driving, avoid sharp turns, especially on slopes.
- It should be remembered that the braking distance of the set increases significantly with the increase in the

weight of the transported load and the increase in speed.

- Control the behaviour of the trailer when driving on uneven terrain and adjust the speed to terrain and road conditions.

**DANGER**

When transporting animals, extreme caution should be exercised due to the possibility of their unexpected movement in the trailer. Dynamic change of centre of gravity can lead to tipping over of the trailer and tractor.

**CAUTION**

Before driving on the road:

- Remove the rear lamp covers,
 - Check that the signal lights are clearly visible and working correctly,
 - Raise the trailer completely up
 - Close the hydraulic valve located on the lifting pipe.
- It is partially or completely forbidden to start or drive the trailer.

H.3.9.614.08.1.PL

4.6 UNLOADING

Before unloading the trailer, it is recommended to place the trailer on a stable and flat surface. Block the vehicle by placing chocks under the wheels and apply the parking brake.

Unloading the trailer should be performed with the following steps with extreme caution:

- unlock the hydraulic valve located on the lifting cable,



CAUTION

The lowering of the load box can only be carried out on a hard and flat surface. It is forbidden to start or drive with the trailer partly or completely lowered.

- lower the trailer using the distributor lever in the operator's cab,
- unfold the side gates (if necessary),
- open the rear door closing paying special attention to ensure that animals do not lean on the door,
- take out animals,
- fold and secure the railings,
- close and secure the rear door.



DANGER

Be careful when opening door closures and locks, as animals may lean on the door.
Be careful when closing the door to avoid crushing your fingers.
Make sure that nobody is near the trailer during unloading.
Unloading may only be carried out when the trailer is connected to the tractor.

H.3.9.614.09.1.PL

4.7 RULES FOR USING THE TIRES

- When working with tires, secure the machine against rolling away by placing chocks under the wheel. The wheel can be dismantled only when the trailer is not loaded.
- Repair work on wheels or tires should be carried out by persons trained and authorized to do so. These works should be carried out using appropriately selected tools.
- Checking the tightening of the wheel nuts should be carried out after the first use of the trailer, every 2-3 hours during the first month of using the machine and then every 30 hours of driving. Each time, repeat all operations if the wheel was disassembled. Wheel nuts should be tightened in accordance with the recommendations contained in the MAINTENANCE chapter.
- Regularly check and maintain proper tire pressure as recommended in the Manual (especially after a long break of not using the trailer).
- Tire pressure should also be checked during all-day intensive work. It should be taken into account that an increase in tire temperature can increase the pressure by up to 1 bar. With such a rise in temperature and pressure, reduce the load or speed.
- Never reduce pressure by venting if it increases due to temperature.
- Valves must be secured with appropriate caps to avoid soiling.
- Do not exceed the maximum trailer speed.
- During the whole day cycle, take a minimum of one hour break at noon.
- Observe 30 minutes breaks for cooling the tires after driving 75 km or after 150 minutes of continuous driving, whichever comes first.
- Avoid damaged road surfaces, sudden and variable manoeuvres, and high speeds when turning.

H.3.4.622.10.1.PL

CHAPTER 5

PERIODIC INSPECTIONS

5.1 GENERAL

When using the trailer, it is necessary to constantly check the technical condition and perform maintenance procedures that will allow the machine to be kept in good technical condition. Therefore, the machine user is obliged to perform all maintenance, control and adjustment activities specified by the Manufacturer in accordance with the assumed schedule. Repairs during the warranty period may only be carried out by Authorized Sales and Service Points (APSiO). In case of unauthorized repairs, changes to factory settings or activities which were not considered as feasible by the operator



DANGER

It is forbidden to use a damaged trailer. The trailer may only be towed when the braking system, the drawbar and the running gear are in working order. Repairs during the warranty period may only be carried out by authorized service centres.

trailer (not described in this manual)

the user loses the warranty.

The trailer's warranty review is only carried out by an authorized service centre.

After the warranty expires, it is recommended that inspections be carried out by specialized repair workshops.

I.3.4.622.01.1.EN

5.2 SCHEDULE OF PERIODIC REVIEWS

Table 5.1. Review categories

Category	Description	Responsible person	Frequency
A	Daily review	Operator	Every day before first start-up or every 10 hours of continuous shift work.
B	Maintenance	Operator	The inspection is carried out periodically every 1000 kilometres travelled or every month trailer operation, whichever comes first. A daily check must be carried out each time before performing this review,
C	Maintenance	Operator	Inspection carried out periodically every 3 months. Each time before carrying out this inspection, a daily inspection and inspection every 1 month of trailer use should be performed.
D	Maintenance	Operator	Inspection carried out periodically every 6 months. Each time before carrying out this inspection, a daily inspection, inspection every 1 month of trailer use and inspection every 3 months should be performed.
E	Maintenance	Operator	Inspection carried out periodically every 12 months. Each time before carrying out this inspection, a daily inspection, inspection every 1 month of trailer use and inspection every 3 months should be performed.
F	Maintenance	Service ⁽¹⁾	Inspection carried out every 4 years of trailer use

(1) - post-warranty service

Table 5.2. Schedule of periodic reviews

Description of actions	A	B	C	D	E	F	Page
Air pressure measurement, inspection of tires and wheels	•						5.10
Air tank drainage	•						5.7
Checking plugs and connection sockets	•						5.8
Checking the trailer before driving off	•						5.9
Air Pressure measurement, inspection of tires and wheels		•					5.10
Cleaning the air filters			•				5.11
Checking brake lining wear				•			5.12
Checking the clearance of the axle bearings				•			5.13
Checking the mechanical brakes				•			5.14
Cleaning the drain valve				•			5.16
Parking brake cable tension adjustment and replacement					•		5.17
Hydraulic system inspection					•		5.18
Pneumatic system inspection					•		5.19
Lubrication	See table: <i>Trailer lubrication schedule</i>						5.22
Checking screw connections	See chapter: <i>Checking screw connections</i>						5.20
Replacement of hydraulic hoses						•	5.28
Replacement of limit valves and limit switches						•	5.28

Table 5.3. Control parameters and settings

Description	Value	Notes
Braking system		
Piston rod stroke in pneumatic systems	25 - 45 mm	
Piston rod stroke in hydraulic systems	25 - 45 mm	
Piston rod stroke in pneumatic and hydraulic systems	25 - 45 mm	
Minimum brake lining thickness	5 mm	
The angle between the expander axis and the support plane	90°	With the brake depressed
Parking brake		
Permitted parking brake cable clearance	10-20 mm	

I.3.9.614.02.1.EN

5.3 TRAILER PREPARATION



DANGER

Secure the tractor cabin against unauthorized access.

When working with the lift, the user must read the instructions for this device and follow the manufacturer's instructions. The jack must stand firmly against the ground and trailer elements.

Before starting maintenance and repair work with the trailer raised, make sure that it is properly secured and will not roll during operation.

- Hitch trailer to tractor.
- Place the tractor and trailer on firm and level ground. Position the tractor for straight-ahead travel.
- Use the tractor parking brake.
- Switch off the tractor engine and remove the ignition key. Close the tractor cabin, thus protecting the tractor against unauthorized access.
- Place blocking wedges under trailer wheel.

Make sure the trailer will not roll during the inspection.

- In case when the wheel needs to be

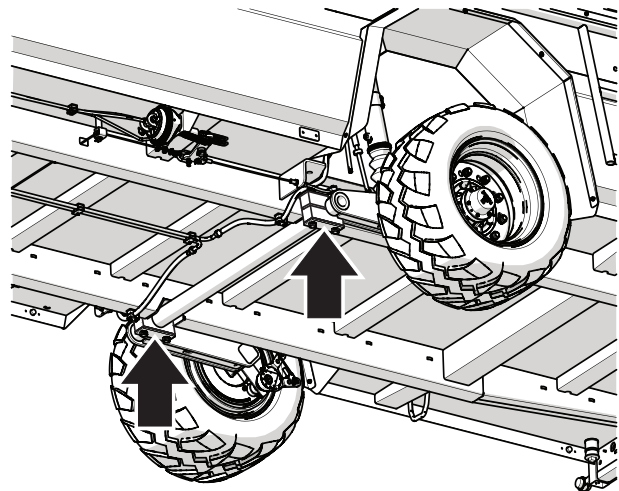

614-I.01-1

Figure 5.1 Recommended jack positioning points

raised during the inspection, place the locking wedges under the wheel on the opposite side. Place the jack in places marked with an arrow.

The lift must rest on a firm and stable surface.

- The jack must be adjusted to the weight of the trailer.
- In exceptional cases release the trailer parking brake, e.g. when measuring the play of the axle bearings. You should be particularly careful.

I.3.9.614.03.1.EN

5.4 AIR TANK DRAINAGE

- Press the stem of the drain valve (1) located at the bottom of the tank (2).

The compressed air from the tank will remove water outside.

- After releasing the stem, the valve should close automatically and stop the outflow of air from the tank.
- If the valve stem does not want to return to its position, wait until the tank empties. Then unscrew and clean or replace the valve with a new one.

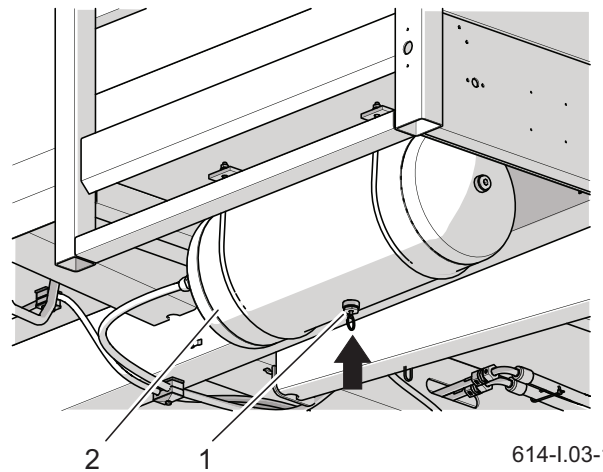

Figure 5.2 Air tank
(1) drain valve (2) air tank

If you need to clean the drain valve, refer to the section *Cleaning of the drain valve*.

I.3.9.614.05.1.EN

5.5 CHECKING PLUGS AND CONNECTION SOCKETS

Damaged connector body or socket to connecting a second trailer qualifies them for replacement. In the event of damage to the cover or gasket, replace these elements with new, functional ones. Contact of pneumatic connection seals with oils, grease, gasoline etc. may damage them and accelerate the aging process.

If the trailer is disconnected from the tractor, connections should be protected with covers or placed in their designated sockets. Before the winter period, it is recommended to preserve the seal with preparations intended for this purpose (e.g. silicone lubricants for rubber elements).

Each time before connecting the machine, check the technical condition and degree of cleanliness of connections and sockets on the agricultural tractor. If necessary clean or repair tractor sockets.

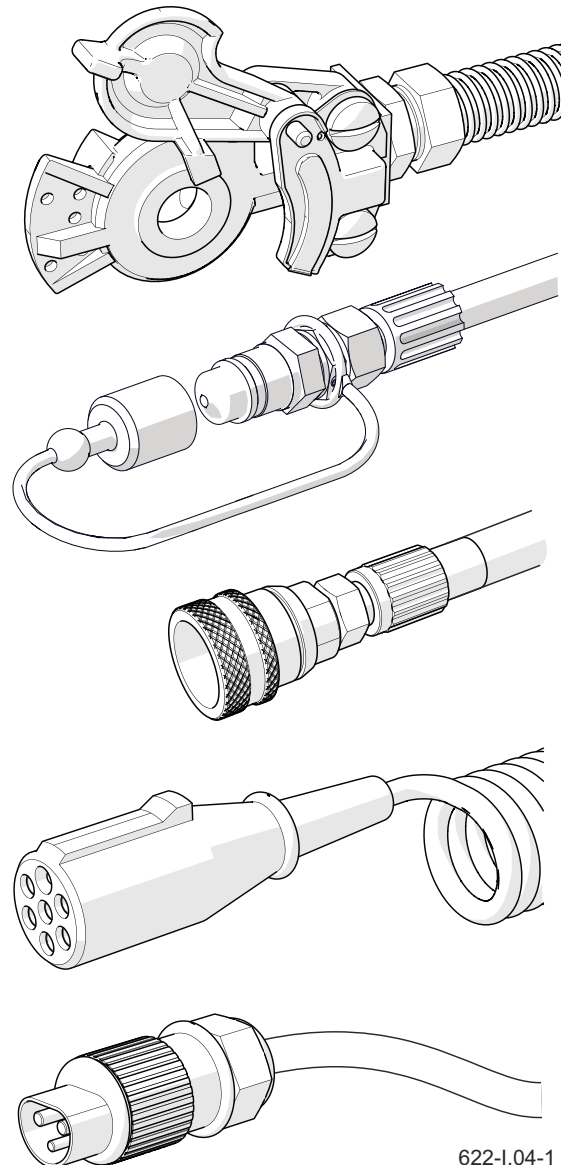

Figure 5.3 Examples of trailer connections

I.3.4.622.06.1.EN

5.6 CHECKING THE TRAILER BEFORE DRIVING OFF

- Before connecting the trailer to the tractor make sure that the hydraulic and pneumatic conduits are not damaged.
- Check the completeness, technical condition and correct functioning of the trailer lighting.
- Check the cleanliness of all electric lamps and reflectors.
- Before travelling on a public road, remove the rear lamp covers and place them in the designated place.
- Check the correct mounting of the triangular plate holder for slow moving vehicles and the plate itself.
- Make sure that the tractor has a reflective warning triangle.
- Check that the actuator ventilation openings are not clogged with dirt and that there is no water or ice inside. Check the correct mounting of the actuator.

Clean the actuator if necessary. In winter, it may be necessary to defrost the actuator and remove accumulated water through unclogged ventilation holes. If any



DANGER

Driving with malfunctioning lighting or braking systems is prohibited. In the event of damage to the trailer, discontinue use until it is repaired.

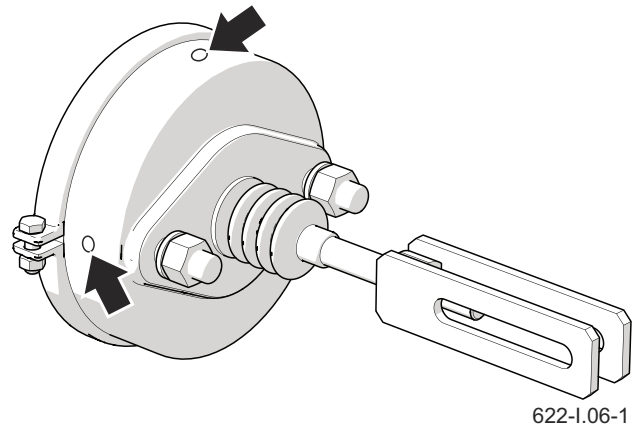

Figure 5.4 Brake cylinder

damage is found, replace the actuator. When mounting the actuator, keep its original position relative to the bracket.

- Check the operation of the service brake system when moving off. For proper operation of the pneumatic system, an appropriate level of air pressure in the trailer's air tank is required.
- Regularly check the correct operation of other systems during trailer operation.

I.3.4.622.08.1.EN

5.7 AIR PRESSURE MEASUREMENT, INSPECTION OF TIRES AND WHEELS

During pressure measurement the trailer must be unloaded. Checks should be carried out before driving off, when the tires are not warm, or after a longer standstill of the trailer.

SCOPE OF ACTIONS

- Connect a pressure gauge to the valve.
- Check air pressure.
- If necessary, inflate the wheel to the required pressure.

The required air pressure is described on a sticker (1) on the rim.

- Check tread depth.
- Check the side wall of the tire.
- Inspect the tire for defects, cuts, deformations, bumps indicating mechanical damage to the tire.
- Check if the tire is correctly positioned on the rim.
- Check tire age.

When checking pressure, pay attention to the technical condition of rims and tires. In the event of mechanical damage, consult your nearest tire service centre and make sure that the tire defect is eligible for replacement. The rims should be checked for deformation, material cracks, weld

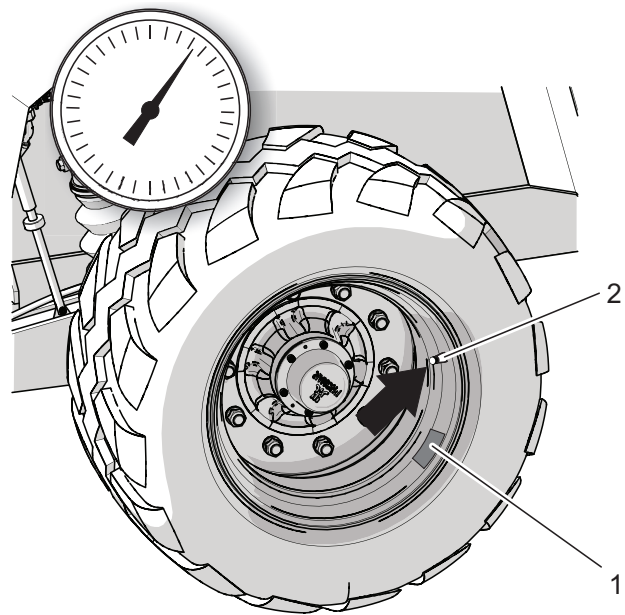

614-I.02-1

Figure 5.5 Trailer wheel
(1) sticker (2) valve

cracks, corrosion, especially around the welds and at the point of contact with the tire.

ADVICE

In the event of intensive use of the trailer, we recommend more frequent pressure checks.



CAUTION

Using the trailer in which tires are not properly inflated may lead to permanent damage to the tire as a result of delamination of the material. Incorrect tire pressure also causes faster tire wear.

I.3.9.614.09.1.EN

5.8 CLEANING THE AIR FILTERS

SCOPE OF ACTIONS

- Reduce pressure in the supply line.
The pressure in the pipe can be reduced by pushing the plug of the pneumatic connection as far as it will go.
- Extend the filter slide (1).
Hold the filter cover (2) with your other hand. After removing the slide, the cover will be pushed out by the spring located in the filter housing.
- Wash the filter element and filter body

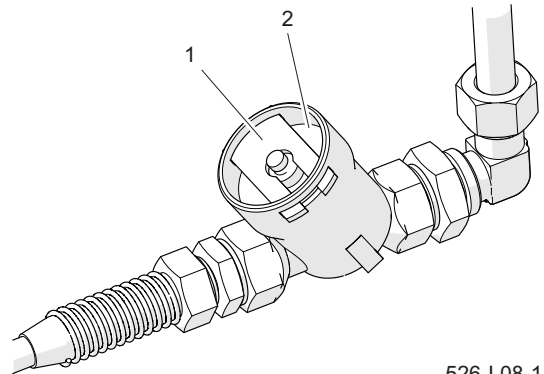

526-I.08-1

Figure 5.6 Air filter
(1) filter slide (2) cover

thoroughly with water and blow with compressed air. Installation should be in reverse order.

I.3.4.622.10.1.EN

5.9 CHECKING BRAKE LINING WEAR

- Locate the inspection hole.

Depending on the version of the running axle, the inspection hole may be located in a different place than the figure shows, but it will always be located on the brake shield.

- Remove the upper and lower plugs and then check the thickness of the lining.
- The brake shoes should be replaced if the thickness of the brake lining is less than 5 mm.
- Check the remaining linings for wear.

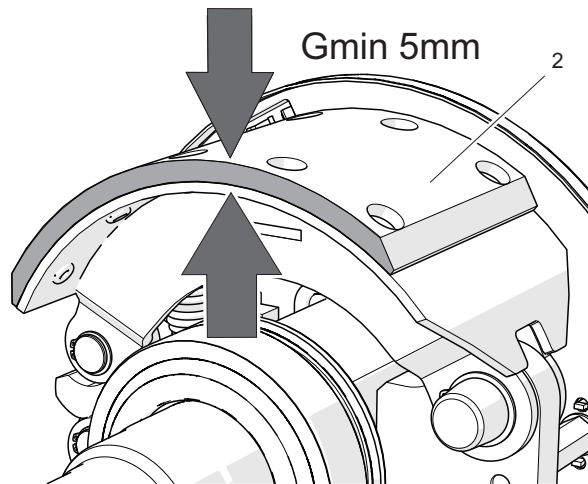
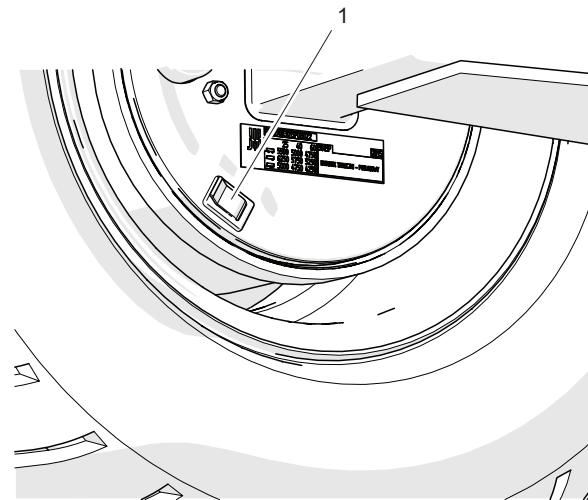

526-I.09-1

Figure 5.7 The brake lining thickness inspection

(1) cap (2) brake lining

I.3.4.622.11.1.EN

5.10 CHECKING THE CLEARANCE OF THE AXLE BEARINGS

- Raise the wheel with a jack.
- Turn the wheel slowly in two directions. Check that the movement is smooth and the wheel rotates without excessive resistance and jams.
- Turn the wheel so that it rotates very quickly, check that the bearing does not make any unusual sounds.
- Try to feel looseness during moving the wheel.
- Repeat this action for each wheel separately, remembering that the jack must be on the opposite side of the wedges.
- If looseness is felt, adjust the bearings. Unnatural sounds coming from the bearing may be symptoms of excessive wear, dirt or damage. In this case, the bearing together with the sealing rings should be replaced or cleaned and regreased. When checking bearings, make sure that any noticeable looseness comes from the bearings, not the suspension



526-I.10-1

Figure 5.8 Clearance inspection

ADVICE

Damaged hub cover or lack thereof will cause the penetration of dirt and moisture into the hub, which will result in much faster wear of bearings and hub seals.

Bearing life depends on trailer operating conditions, load, vehicle speed and lubrication conditions.

system (e.g. looseness on the spring pins, etc.).

- Check the technical condition of the hub cover, replace with a new one if necessary.

I.3.4.622.12.1.EN

5.11 CHECKING THE MECHANICAL BRAKES

ADVICE

Checking the technical condition of the brakes:

- according to the schedule of inspections,
- before the period of intensive use,
- after repairing the braking system.
- in the event of uneven braking of the trailer wheels.

In a correctly adjusted brake, the stroke of the brake cylinder piston should be within the range specified in Table (5.3) and depends on the type of cylinder used. When the wheel is fully braked, the optimal angle between the expander lever and the piston rod should be approx. 90°. With this setting, the braking force is optimal. Checking the brakes consists in measuring this angle and the piston rod stroke in each wheel.

SCOPE OF ACTIONS

- Measure the distance X with the tractor brake pedal released.
- Measure the distance Y with the tractor brake pedal pressed.
- Calculate the distance difference X-Y (rod stroke).
- Check the angle between the cylinder

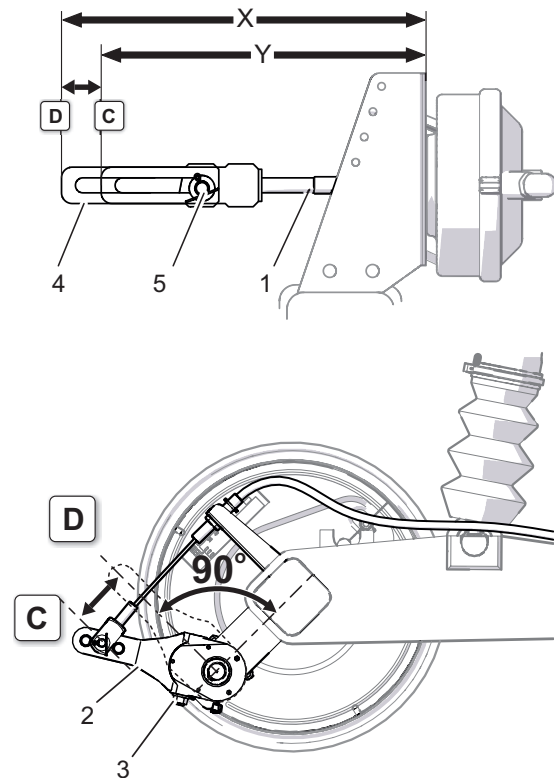

Figure 5.9 Brake check

- (1) cylinder piston (2) expander arm
 (3) adjustment screw (4) of the cylinder fork
 (5) pin position
 (C) arm in the uninhibited position
 (D) arm in the inhibited position

piston axis and the expander lever.

- If the expander arm angle (2) and piston rod stroke exceed the range given in table (5.3), the brake should be adjusted.

I.3.4.622.13.1.EN

5.12 CLEANING THE DRAIN VALVE

- Fully reduce the pressure in the air reservoir (2).

The pressure in the tank can be reduced by swinging the drain valve stem.

- Unscrew the valve (1).
- Clean the valve, blow with compressed air.
- Replace the gasket.
- Screw in the valve, fill the tank with air, check the tank for leaks.

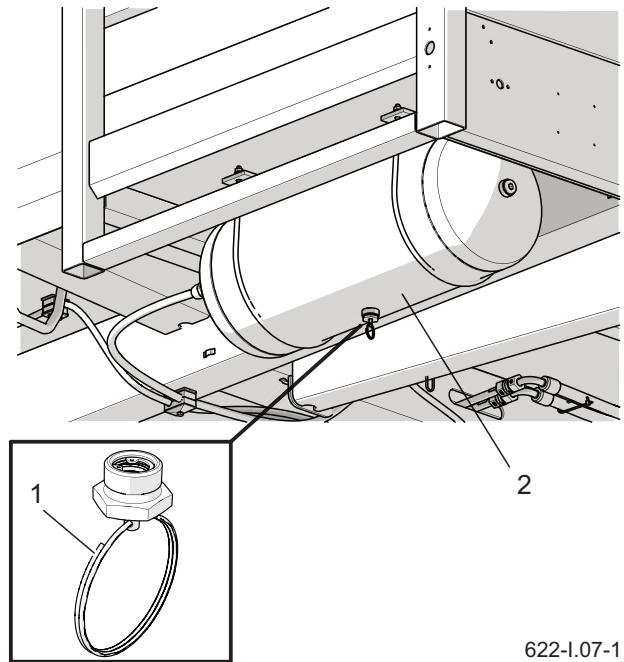

622-I.07-1

Figure 5.10 Air tank
(1) drain valve (2) tank

I.3.9.614.14.1.EN

5.13 PARKING BRAKE CABLE TENSION ADJUSTMENT

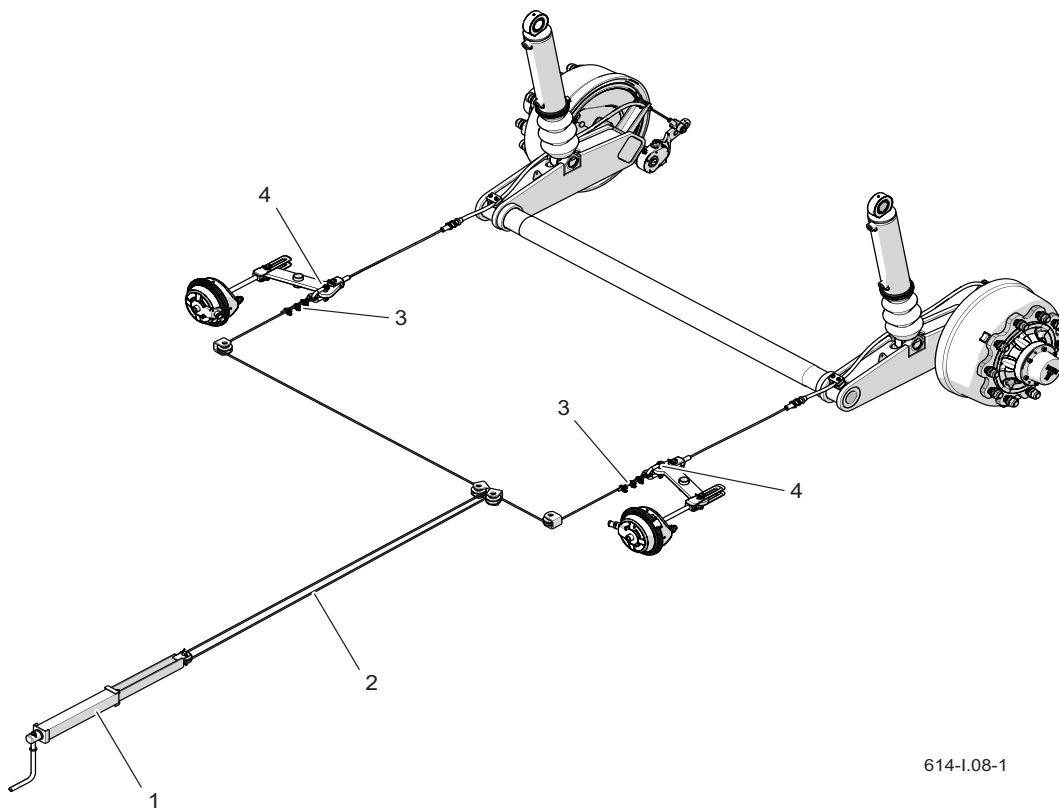

614-I.08-1

Figure 5.11 Cable tension inspection

(1) brake crank mechanism, (2) hand brake cable, (3) cable clamp, (4) shackle,

CABLE TENSION ADJUSTMENT

The correct operation of the parking brake depends on the effectiveness of the brakes on the rear axle and the correct tension of the brake cables.

- Hitch trailer to tractor. Place the trailer and tractor on a level surface.
- Place blocking wedges under trailer wheel.
- Unscrew the brake mechanism screw (1) as far as possible.

- Loosen the bow clamp nuts (3) on the handbrake cable (1).
- Tighten the cable (2) and tighten the clamp nuts (3).

The parking brake cable length should be selected so that when the service and parking brake is completely released, the cable is loose and hangs 1-2 cm

Adjustment of parking brake cable tension should be carried out in the case of:

- cable stretching,

- loosening the parking brake cable clamps,
- after adjusting the axle brake
- after repairs to the axle brake system,
- after repairs to the parking brake system.
- Lubricate the parking brake mechanism (1) as well as the lever pins and pulleys.
- Install a new cable, adjust the tension.

I.3.9.614.15.1.EN

5.14 HYDRAULIC SYSTEM INSPECTION

- Hitch trailer to tractor.

Each time before connecting the trailer to the tractor or connecting a second trailer, check the hydraulic connectors and sockets.

- Secure the tractor and trailer with the parking brake.
- Clean hose connections, hydraulic cylinders and couplings.
- Start all hydraulic systems several times by extending and retracting the piston rods of the cylinder.
- Start all hydraulic systems several times by extending and retracting the piston rods of the cylinder.
- Check all hydraulic circuits for leaks.
If necessary tighten the connectors if moisture is visible.
- After completing the inspection, put all cylinders to the rest position.

If visible moisture appears on the cable connectors, tighten the connectors at the specified torque and retest. If the problem persists replace the leaking element.

In the event of oiling on the hydraulic cylinder body, the nature of the leakage must be checked. When the cylinder is fully extended, check the seal locations. Minor leaks are permissible with symptoms of "sweating", however

in the event of noticing leaks in the form of "droplets", stop using the trailer until the fault is remedied. If a malfunction has appeared in the brake cylinders, it is forbidden to drive the trailer with a damaged system until the fault is removed.



DANGER

It is forbidden to use the trailer with a defective pneumatic system.
It is forbidden to use the trailer with a defective parking brake system.

I.3.4.622.16.1.EN

5.15 PNEUMATIC SYSTEM INSPECTION

- Hitch trailer to tractor.
- The tractor and trailer should be immobilized with the parking brake. Additionally, place wedges under the rear wheel of the trailer.
- Start the tractor to supplement the air in the trailer braking system tank.

In double conduit systems, the air pressure should be around 6.5 bar.

- Switch off the tractor engine.
- Check the system components with the tractor brake pedal released.

Pay special attention to cable connections and brake cylinders.

- Repeat the system check with the tractor brake pedal depressed.

The help of another person is required.



DANGER

It is forbidden to use the trailer with a defective brake system.

In the event of a leak, the compressed air will leak out in places of damage with a characteristic hissing. The system leak can also be detected by coating the checked elements with washing liquid or other foaming agent, which will not aggressively affect the elements of the installation. Damaged elements should be replaced or sent for repair. If there is a leak around the connections, tighten the connector. If air still leaks, replace the connector components or seals with new ones.

I.3.4.622.17.1.EN

5.16 CHECKING SCREW CONNECTIONS

TIGHTENING TORQUES FOR SCREW CONNECTIONS

During maintenance and repair work, apply appropriate tightening torques to screw connections, unless other tightening parameters are given. Recommended tightening torques for the most commonly used screw connections are presented in table (5.4). The given values apply to non-lubricated steel bolts.

The hydraulic hoses should be tightened with a torque of 50-70Nm.

Check the tightness using a torque wrench. During daily trailer inspection pay attention to loose connections and tighten the connector if necessary. Replace lost items with new ones.

Table 5.4. Tightening torque

Thread	Tightening torque	
	8.8	10.9
M8	25	36
M10	49	72
M12	85	125
M14	135	200
M16	210	310
M20	425	610
M24	730	1,050
M27	1,150	1,650
M30	1,450	2,100

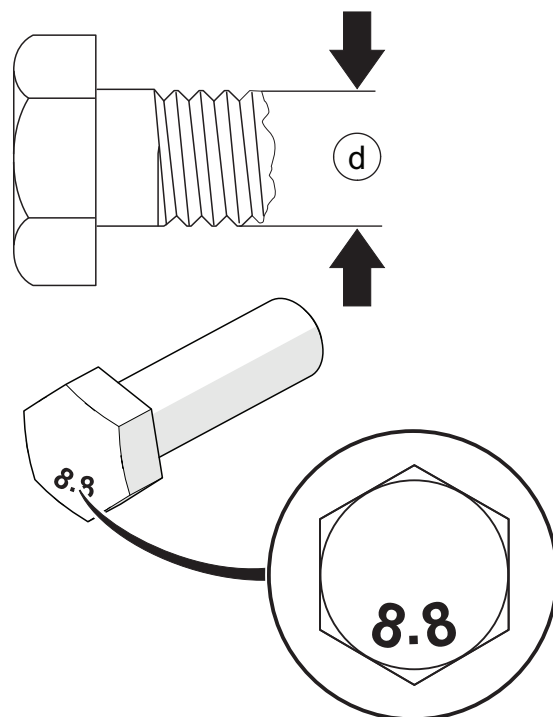

D.3-1

Figure 5.12 Metric thread screw

TIGHTENING OF THE WHEEL NUTS.

The wheel nuts should be tightened gradually diagonally (in several stages until the required tightening torque is achieved), using a torque wrench. The recommended order of tightening the nuts and the tightening torque is shown in the figure Principle of the wheel tightening.

Wheel nuts must not be tightened with impact wrenches, due to the danger of exceeding the permissible tightening torque, which may result in breaking the connection thread or breaking the hub pin.

The wheels should be tightened according to the following scheme:

- after the first use of the trailer (one-time inspection),

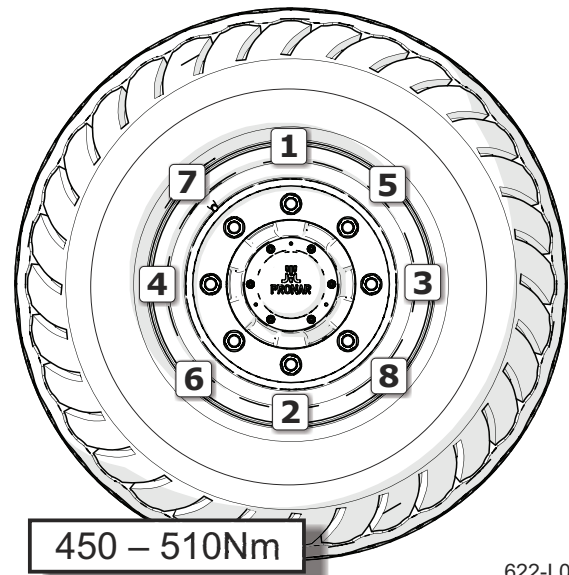

Figure 5.13 Wheel tightening principle

- every 2-3 hours of driving during the first month of use,
- every 30 hours of driving.

If the wheel was disassembled, the above steps should be repeated.

I.3.9.614.18.1.EN

5.17 LUBRICATION

- The trailer should be lubricated with a hand or foot grease gun, filled with the recommended lubricant. If possible, remove old grease and other contaminants before starting work. After finishing work, wipe off excess grease.
- Parts that should be lubricated using machine oil should be wiped with a dry clean cloth. Apply the oil with a brush or oiler. Wipe off excess oil.
- The replacement of grease in wheel hub bearings should be entrusted to specialized service points equipped with the appropriate tools. Remove the entire hub, remove the bearings and individual sealing rings. After thorough cleaning and inspection, install lubricated components. If necessary, replace the bearings and seals with new ones.
- Empty containers of grease or oil should be disposed of in accordance with the lubricant manufacturer's instructions.

Table 5.5. Lubricants

Item	Symbol	Description
1	A	general purpose machine grease (lithium, calcium),
2	B	solid grease for heavily loaded components with the addition of MoS ₂ or graphite
3	C	anti-corrosive spray
4	D	plain machine oil, silicone spray grease

ADVICE

Lubrication schedule (Table *Trailer Lubrication schedule*):

D - working day (8 hours of trailer work),

M - month

Table 5.6. Trailer lubrication schedule

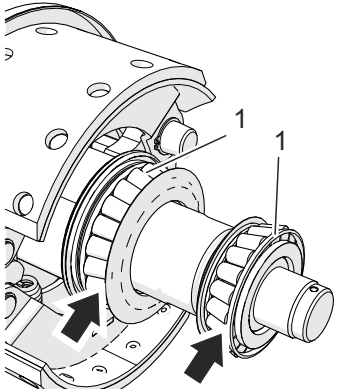
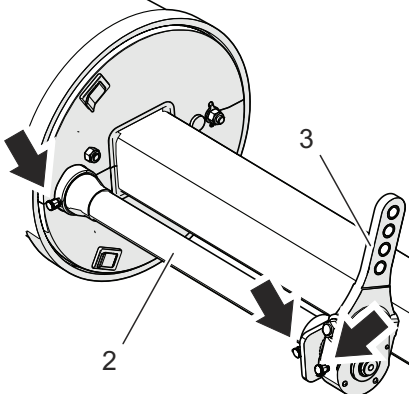
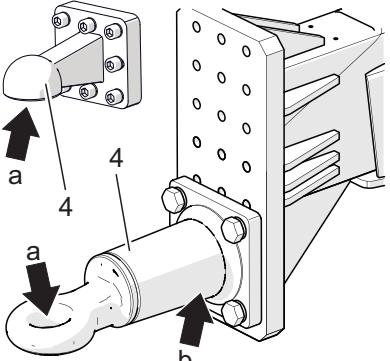
Item	Name	Number of points	Type of grease	Frequency	
1	Hub bearing (2 pieces in each hub)	4	A	24M	
2	Expander shaft bushing	4	A	3M	
3	Expander arm	2	A	3M	
4a	Drawbar eye	1	B	14D	
4b	Rotary drawbar	1	B	1M	

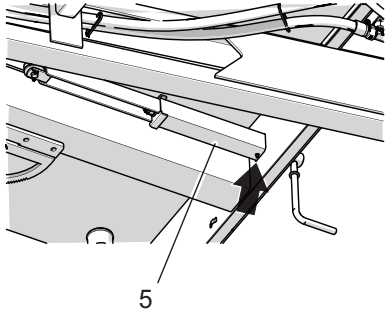
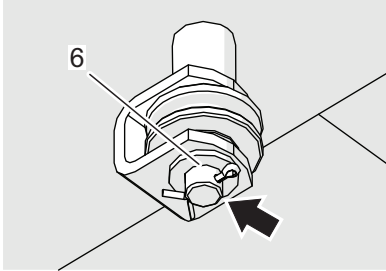
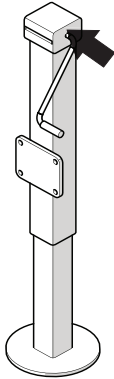
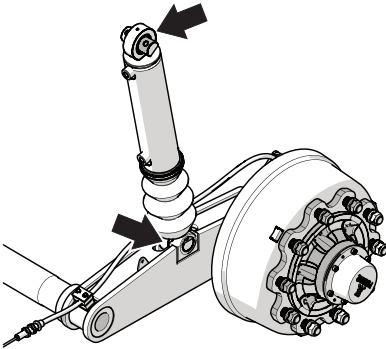
Item	Name	Number of points	Type of grease	Frequency	
5	Parking brake mechanism	1	A	6M	
6	Parking brake guide pins	5	A	3M	
7	Parking stand	1	A	6M	
8	Hydraulic cylinder eyes, suspension	4	A	6M	

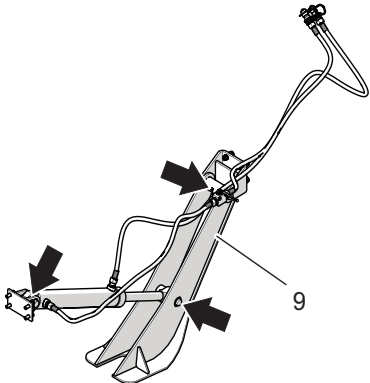
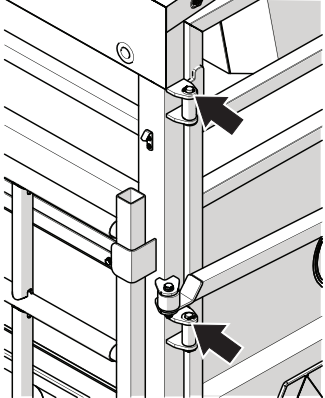
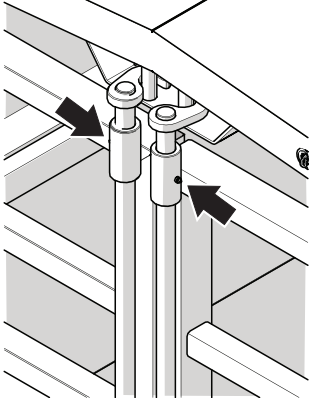
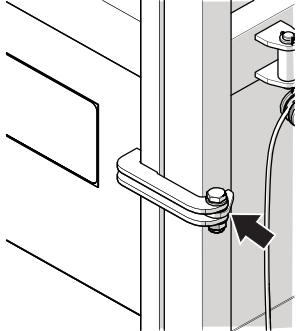
Item	Name	Number of points	Type of grease	Frequency	
9	Scissor support	3	A	6M	
13	Rear door hinges	6	A	3M	
14	Rear door locking mechanism	4	A	3M	
15	Side door hinges	2	A	3M	

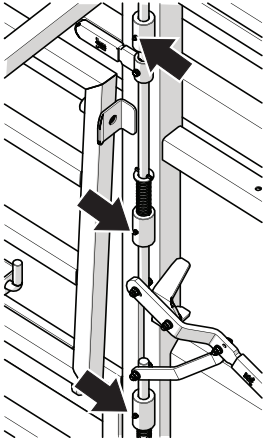
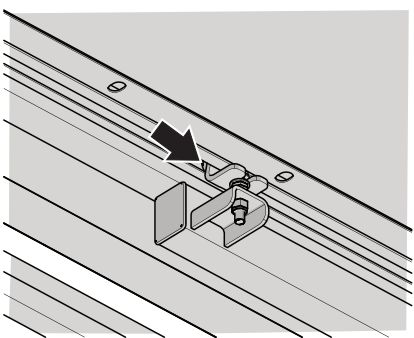
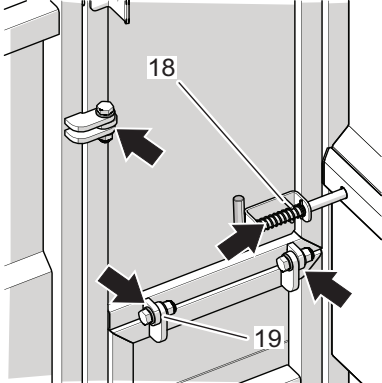
Item	Name	Number of points	Type of grease	Frequency	
17	Partition locking mechanism	4	A	3M	
20	Partition guides	2	A	3M	
18	Bolts	7	A	3M	
19	Partition hinges	6	A	3M	

I.3.9.614.19.1.EN

5.18 REPLACEMENT OF HYDRAULIC HOSES

Rubber hydraulic conduits must be replaced every 4 years regardless of their technical condition. his operation should be entrusted to specialized workshops.

I.3.4.622.20.1.EN

5.19 REPLACEMENT OF LIMIT VALVES AND LIMIT SWITCHES

Limit valves and limit switches (sensors) should be replaced every 4 years, regardless of their technical condition. This operation should be entrusted to specialized workshops.

I.3.4.622.22.1.EN

CHAPTER 6

TECHNICAL SUPPORT

6.1 WHEEL ASSEMBLY AND DISASSEMBLY

WHEEL DISASSEMBLY

- Before lifting the wheel that will be removed, loosen the wheel nuts in the order given in the drawing.
- Place locking wedges on the opposite side of the disassembled wheel.
- Place the jack under the axle between the spring mount bolts (See chapter: Trailer preparation).

The used lift should have adequate load capacity, it should be technically sound.

- If necessary, use properly selected sleepers to reduce the unit pressure of the lift base on the ground to prevent penetration into the ground.
- Raise the trailer to such a height that the wheel being changed does not rest on the ground.
- Remove the wheel.

WHEEL ASSEMBLY

- Use a wire brush to clean the axle pins and nuts from dirt. If necessary, degrease the thread.

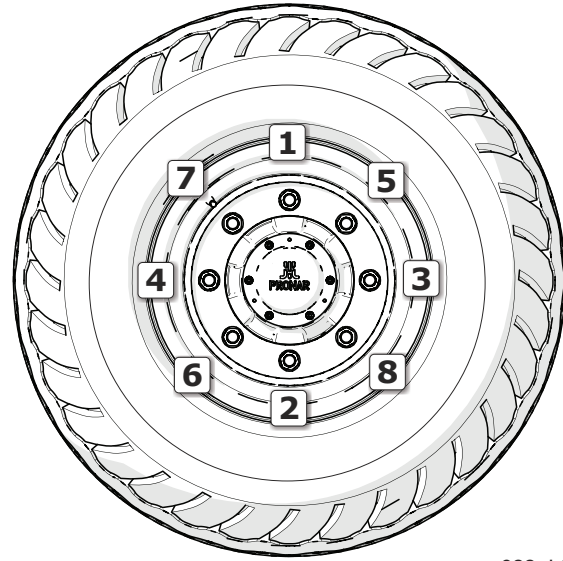

622-J.01-1

Figure 6.1 The order of the nuts tightening



DANGER

Before starting work, read the instructions for the lift and follow the manufacturer's instructions. The lift must stand firmly against the ground and the axle. Ensure that the trailer will not roll when dismantling the wheels.

Do not lubricate the threads of the nut and stud.

- Check the condition of the pins and nuts, replace if necessary.
- Mount the wheel on the hub, tighten the nuts so that the rim fits snugly to the hub.
- Lower the trailer, tighten the nuts according to the recommended torque and the given order.

J.3.4.622.01.1.EN

6.2 PARKING BRAKE CABLE REPLACEMENT

- Hitch trailer to tractor. Place the trailer and tractor on a level surface.
- Place blocking wedges under trailer wheel.
- Unscrew the brake mechanism screw as far as possible.
- Loosen the nuts (4) of the bow clamps (5) at the ends of the cable (1) that you want to replace.
- Remove the shackles, pins, clamps and the cable to be replaced.
- Clean the parking brake components.
- Lubricate the parking brake crank mechanism and pins of the cable guide rollers
- Attach a new cable or links.

The thimbles and three bow clamps must be fitted at the ends of the rope. Pay attention to the correct positioning of the terminals - see drawing.

- Install pins and new securing caps.
- Adjust the parking brake cable tension. Tighten the cable and tighten the clamps. The parking brake cable length should be selected so that when the service and parking brake

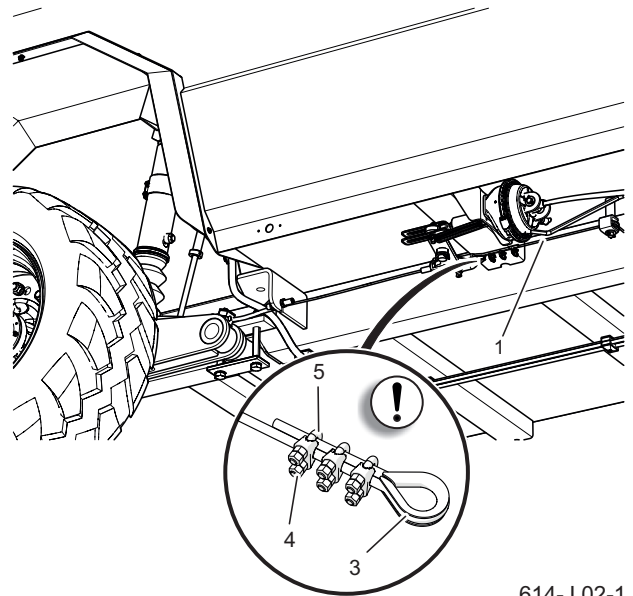

614-J.02-1

Figure 6.2 Parking brake cable replacement
 (1) brake cable (3) thimble
 (4) nut (5) clamp



CAUTION

Clamp jaws must be placed on the load-carrying cable side - see illustration.
 Secure the ends of the cable with a heat shrink tube.
 The distance between the clamps should be 40 mm, with the first clamp placed as close as possible to the thimble.

is completely released, the cable is loose and hangs 1-2 cm

- After the first load on the brake, check the tension and condition of the cable ends, adjust if necessary.

J.3.9.614.03.1.EN

6.3 ADJUSTMENT OF THE CLEARANCE OF THE AXLE BEARINGS

- Remove the hub cover (1).
- Remove the cotter pin (2) securing the castellated nut (3).
- Tighten the castellated nut to remove slack.

The wheel should rotate with slight resist.

- Unscrew the nut (3) (not less than 1/3 of a turn) to cover the nearest groove of the nut with a hole in the journal of the axle (the pin's hole is marked with a black arrow in the drawing). The wheel should rotate with slight resist.

Do not over tighten the nut. Too much pressure is not recommended due to deterioration of bearing operating conditions.

- Secure castellated nut with cotter pin and mount hub cap (1).
- Gently tap the hub with a rubber or wooden hammer.

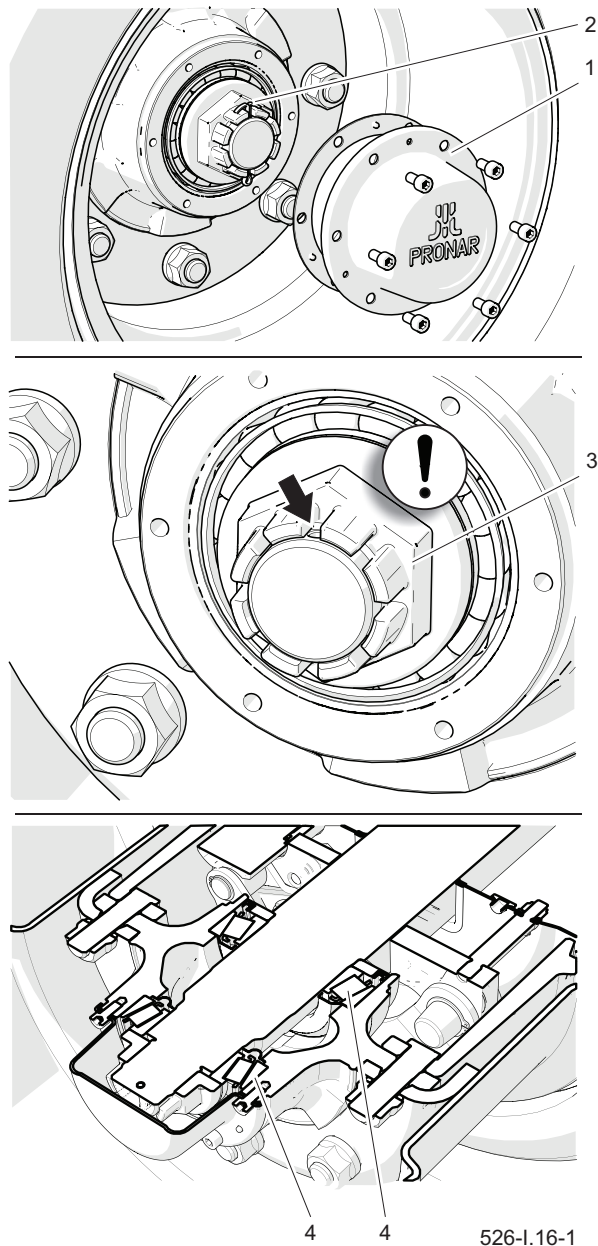

Figure 6.3 The principle of bearing clearance adjustment

(1) hub cap (2) cotter pin

(3) nut (4) tapered roller bearing

CAUTION

Adjustment of bearing clearance may be performed only when the trailer (without load) is connected to the tractor.

6.4 BRAKE ADJUSTMENT

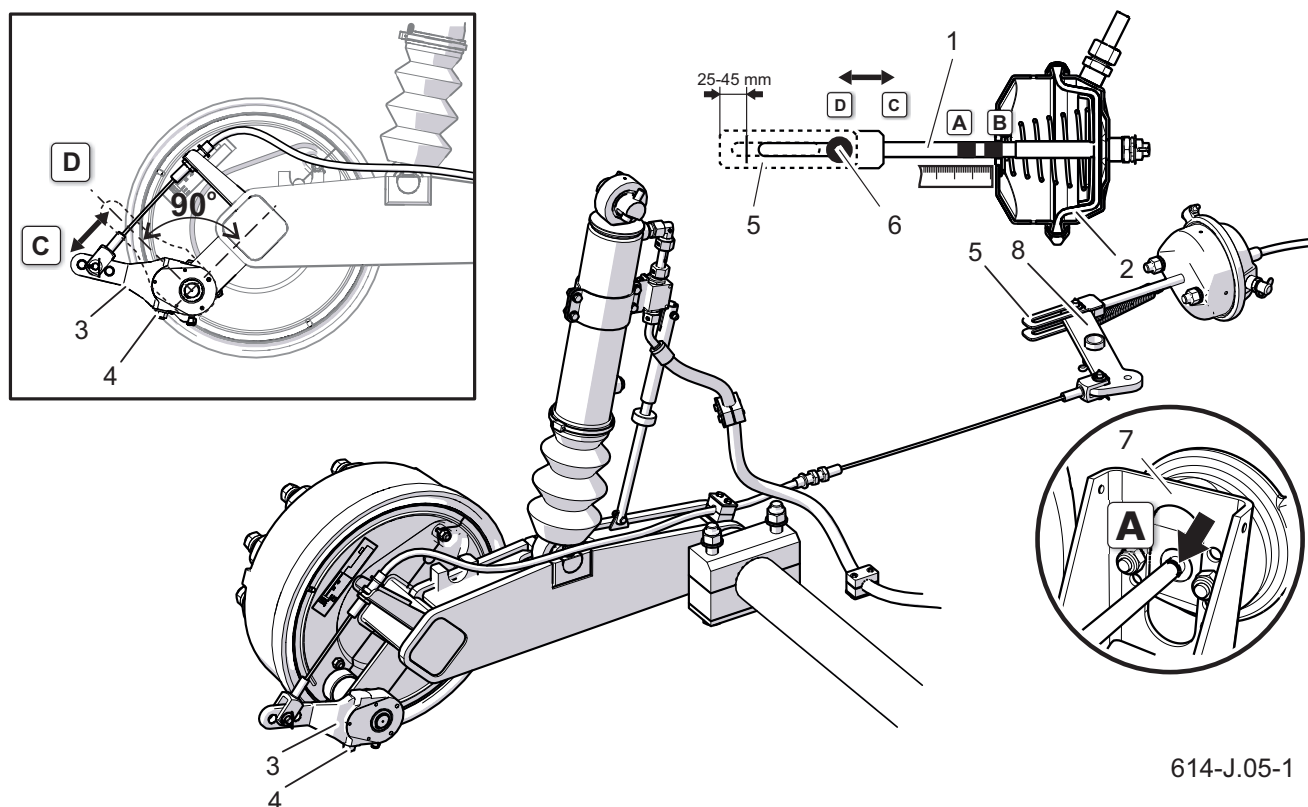

614-J.05-1

Figure 6.4 Brake adjustment

(1) piston rod (2) diaphragm (3) expander lever (4) adjusting screw

(5) cylinder fork (6) pin position (7) cylinder bracket

(A) mark on piston rod in unbraked position (B) mark on piston rod in braked position

(C) position of the arm in the unbraked position (D) position of the arm in the fully braked position

During trailer operation, drum brake friction linings are subject to wear. The stroke of the brake lever and piston increases and the braking force decreases. Adjustment must be carried out when:

- the cylinder piston stroke is 2/3 of the maximum stroke,
- the expander levers are not parallel to each other during braking,
- the braking system was repaired.

Trailer wheels must brake simultaneously. The brakes are adjusted by changing the

position of the expander arm (3) - figure (6.4), relative to the expander shaft.

The scope of service activities:

- Secure the trailer with additional wedges.
- Release the trailer parking brake.
- Remove the actuator fork pin
- On the cylinder piston rod (1) - figure (6.4) mark with a line the position of the maximum retraction of the piston rod (A).
- Press the brake pedal on the tractor,

mark with a line the position of the maximum extension of the piston rod (B).

- Measure the distance between the lines (A) and (B). If the piston rod stroke is not within the correct working range - 25-45mm, adjust the expander lever.
- Check that the cylinder piston moves freely and within the full nominal range.
- Check the correct mounting of the actuator.
- Check that the actuator ventilation openings are not clogged with dirt and that there is no water or ice inside.
- Clean the actuator, defrost if necessary and remove water through the vent holes. If damage is found, replace the actuator with a new one. When mounting the actuator, keep its original position relative to the bracket (7).
- Turn the adjusting screw (4) so that the marked hole of the brake lever (8) matches the hole of the cylinder fork.

During adjustment, the

diaphragm (2) must rest on the rear wall of the actuator.

- Install the piston rod fork pin and washers and secure the pin with cotter pins.
- Turn the adjustment screw (4) clockwise to make one or two clicks in the expander lever adjustment mechanism.
- Repeat the adjustment on the second cylinder.
- Apply the brake.
- Wipe previous markings and measure piston rod stroke again.
- If the piston rod stroke is not within the correct operating range, repeat the adjustment.

FUNCTIONAL CHECK

- After completing the adjustment, carry out a test drive.
- Perform several brakes. Stop the trailer and check the temperature of the brake drums.
- If any drum is too hot, correct the brake adjustment and perform the test drive again.

J.3.9.622.05.1.EN

6.5 ADJUSTING THE DRAWBAR HITCH POSITION



DANGER

Changing of the drawbar position should be done by two people. Be extremely careful when removing the screws because of possible crushing of the foot. The trailer drawbar must be screwed with 8 screws. After changing the drawbar position, check the tightening torques of the screw connections after a full day operation cycle.

It is necessary to adjust the position of the machine's drawbar to the hitch on the tractor. Four different drawbar position height can be set for the lower or upper drawbar. Changing of the drawbar position should be done by two people. To do this:

- Put the trailer on a flat surface, put blocking wedges under the wheels,
- set the trailer on a flat surface, put blocking wedges under the wheels,
- extend or retract the support to such a height that the trailer frame is parallel to the ground,
- unscrew and remove the screws (4) securing the drawbar to the front plate (3),
- adjust the height of the drawbar assembly depending on the needs,

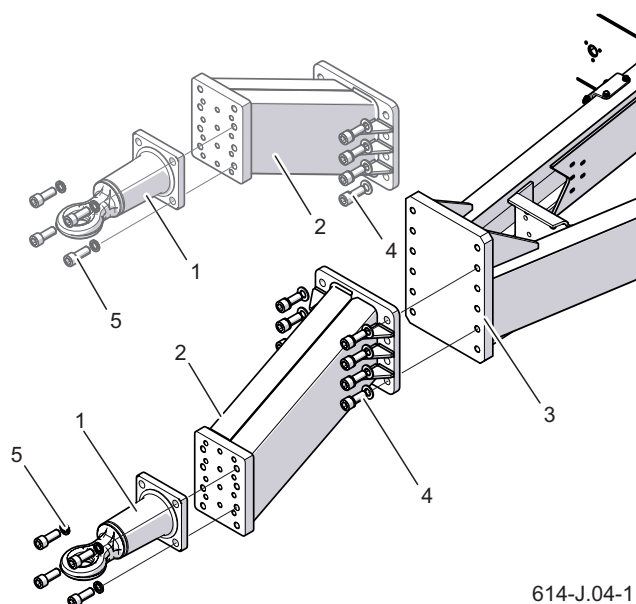

614-J.04-1

Figure 6.5 Adjusting the position of the drawbar eye

- (1) drawbar eye (2) drawbar
- (3) trailer frame front plate
- (4) drawbar screw connection
- (5) bolted connection of the tie rod

- changing of the position of the drawbar from the top to the bottom and vice versa is done by turning the drawbar in the plane of the front plate,
- install the screws and fasten the elements to the correct torque.
- The mounting height and drawbar positions must be selected individually depending on the hitch on the tractor.



CAUTION

Correct adjustment of the drawbar eye position significantly simplifies trailer aggregation. After adjustment the drawbar eye should be horizontal.

6.6 OPERATION OF ELECTRICAL INSTALLATION AND WARNING ELEMENTS



CAUTION

Driving with defective lighting installations is prohibited. Damaged lamps must be replaced immediately before driving off. Lost or damaged reflectors should be replaced with new ones.

Before travelling, make sure that all lamps and reflectors are clean.

Electrical installation service is reduced to periodic inspection of the control system and lighting system.

Work related to the repair, replacement or regeneration of electrical installation components should be entrusted to specialized workshops that have appropriate technologies and qualifications to perform this type of work.

The user's duties include only technical inspection of the electrical installation and reflectors.

SCOPE OF ACTIONS

- After aggregating the trailer with the tractor, connect the cables supplying the lighting electrical system.

Make sure that the connecting cables are functional. Check the connection sockets on the tractor and on the trailer. If necessary, clean all dirt and dust.

- Check the completeness, technical condition and correct functioning of the trailer lighting.

Check the wiring harness for damage (rubbed insulation, wire break, etc.). Check the completeness of the lamps and all reflectors.

- Check the correct mounting of the triangular plate holder for slow moving vehicles.
- Before travelling on a public road, make sure that the tractor has a reflective warning triangle.

ADVICE

The light source in the lamps are LEDs and in case of damage are only replaced as a complete lamp without the possibility of repair or regeneration.

J.3.4.622.07.1.EN

6.7 CONSUMABLES

HYDRAULIC OIL

It is absolutely necessary to observe that the oil in the trailer's hydraulic system and the tractor's hydraulic system must be of the same type. If different types of oil are used, make sure that both hydraulic means can be mixed together. The use of different types of oil may cause damage to the trailer or agricultural tractor. The new machine is filled with L HL32 Lotos hydraulic oil.

If you need to change the hydraulic oil for another oil, read the oil manufacturer's instructions carefully. If he recommends flushing the system with an appropriate preparation, follow these recommendations. It must be ensured that the chemicals used for this purpose do not act aggressively on the materials of the hydraulic system. During normal operation of the trailer, it is not necessary to change the

hydraulic oil, however, if necessary, this operation should be entrusted to specialist service centres.

The oil used is not classified as a dangerous substance due to its composition, however, long-term effects on the skin or eyes may cause irritation. In the event of contact of oil with skin, wash the area of contact with water and soap. Do not use organic solvents (petrol, kerosene). Soiled clothing should be removed to prevent oil from getting on your skin. If oil gets into your eyes, flush them with plenty of water and seek medical attention if irritation occurs. Hydraulic oil under normal conditions is not harmful to the respiratory tract. The hazard only occurs when the oil is strongly atomized (oil mist), or in the event of a fire during which toxic compounds may be released. Oil should be quenched with carbon dioxide, foam or extinguishing

Table 6.1. Oil characteristics L-HL 32

Item	Name	Unit	
1	Viscosity classification according to ISO 3448VG	-	32
2	Kinematic viscosity at 400C	mm ² /s	28.8 – 35.2
3	Qualitative classification according to ISO 6743/99	-	HL
4	Qualitative classification according to ISO 51502	-	HL
5	Flash-point	C	230

steam. Do not use water to extinguish a fire.

LUBRICANTS

For heavily loaded parts, it is recommended to use lithium grease with the addition of molybdenum disulphide (MoS_2) or graphite. For less loaded components, it is recommended to use general-purpose machine greases that contain anti-corrosive additives and are highly resistant to water washout. Aerosol preparations (silicone greases, anti-corrosive lubricants) should have similar properties.

Before using lubricants, read the information leaflet for the selected product. Particularly important are safety rules and how to handle a given lubricant and how to dispose of waste (used containers, contaminated rags, etc.). The information leaflet (product card) should be kept together with the grease.

ADVICE

Lubrication schedule (Table *Trailer lubrication schedule*):

Table 6.2. Lubricants

Item	Symbol	Description
1	A	general purpose machine grease (lithium, calcium),
2	B	solid grease for heavily loaded components with the addition of MoS_2 or graphite
3	C	anti-corrosive spray
4	D	plain machine oil, silicone spray grease

J.3.4.622.09.1.EN

6.8 TROUBLESHOOTING

Table 6.3. Defects

Defects	Possible cause	Solution
Trouble starting.	Brake system lines not connected.	Connect the brake lines.
	Parking brake applied.	Release the trailer parking brake.
	Pneumatic connection lines damaged.	Replace.
	Connection leak.	Tighten, replace washers or sealing sets, replace hoses.
	Defective control valve or braking force regulator.	Check valve, repair or replace.
	Low pressure in pneumatic system.	Fill the system with a suitable pressure
Noise in the hub of the axle.	Excessive bearing looseness.	Check the clearance and adjust if necessary.
	Damaged bearings.	Replace bearings.
	Damaged hub components.	Replace.
Low braking efficiency.	System pressure too low.	Check the pressure on the pressure gauge on the tractor, wait for the compressor to fill the tank to the required pressure.
	System leakage.	Check installations for leaks.
	Damaged tractor air compressor.	Repair or replace.
	Damaged brake valve on the tractor.	Repair or replace.
Excessive heating of the axle hub.	Incorrectly adjusted service or parking brake.	Adjust expander arm positions or parking brake cable tension.
	Worn brake pads.	Replace brake shoes.

Defects	Possible cause	Solution
Incorrect hydraulic system operation.	Incorrect hydraulic oil viscosity.	Check oil quality, make sure the oils in both machines are of the same grade. If necessary, change the oil in the tractor and/or trailer.
	Contaminated hydraulic oil.	Check oil cleanliness, change filters, change oil, clean tank.
	Incorrect oil level.	Check oil level and make up for leaks.
Incorrect hydraulic system operation.	Damaged or dirty actuator.	Check the cylinder piston rod (bending, corrosion), check the cylinder for leaks (piston rod seal), repair or replace the cylinder if necessary.
	Actuator load too high.	Check and reduce the cylinder load if necessary.
Incorrect hydraulic system operation.	Deregulated valves or limit switches	Adjust limit valves and limit switches
	Damaged hydraulic lines.	Check and make sure that the hydraulic hoses are tight, not kinked and properly tightened. Replace or tighten as necessary.
	Damaged hydraulic quick couplings.	Replace.
Impossible to lower or raise the trailer	Hydraulic lines not connected	Connect the hydraulic hoses
	Closed hydraulic valve	Set the valve to the "open" position
	Insufficient tractor hydraulic pump performance, tractor hydraulic pump defective.	Check oil level. Check the hydraulic pump on the tractor.
	Insufficient amount of hydraulic oil in the tractor's hydraulic system.	Use a tractor with hydraulic oil capacity that matches the trailer oil demand.
	Air in the hydraulic circuit	Operate the lever several times in both directions until proper operation is obtained.

Defects	Possible cause	Solution
Excessive wear of the left and right shoulder tires on both sides.	Air pressure too low. Too high cornering speed. Too fast air loss due to damaged rim, valve, puncture e.g.	Check air pressure. Check the road tires for proper inflation regularly. Reduce speed when cornering on a hardened surface. Check rim and valve. Replace damaged parts.
Excessive tire wear in the centre.	Air pressure too high.	Check air pressure. Check the road tires for proper inflation regularly.
Excessive unilateral wear on the left or right shoulder tires.	Incorrect convergence. Driving axes incorrectly set.	Damaged spring leaf on one side of the suspension. Replace the springs.
Tread wear.	Damaged suspension system, broken spring. Damaged braking system, brake blocking, incorrectly adjusted braking system. Too frequent and sudden braking.	Check the slack in the suspension system, check the springs. Replace damaged or worn parts. Check the braking system for malfunctions. Adjust the extender levers.
Lateral fracture.	Long-lasting ride on tires with low air pressure. Machine load is too high.	Check air pressure regularly. Check the weight of the load during loading.
Abrasions on the lateral outer edge of the tire.	Too frequent climbing over sharp, high obstacles (e.g. curbs).	Control the driving technique.
Rim damage (hardening and cracking around the rim), tire crumbling.	Incorrect braking technique. Too frequent and sudden braking. Braking system damaged.	Check braking system. Control the braking technique. Damage arises due to excessive heating of the hub and the resulting wheel rims.

APPENDIX A

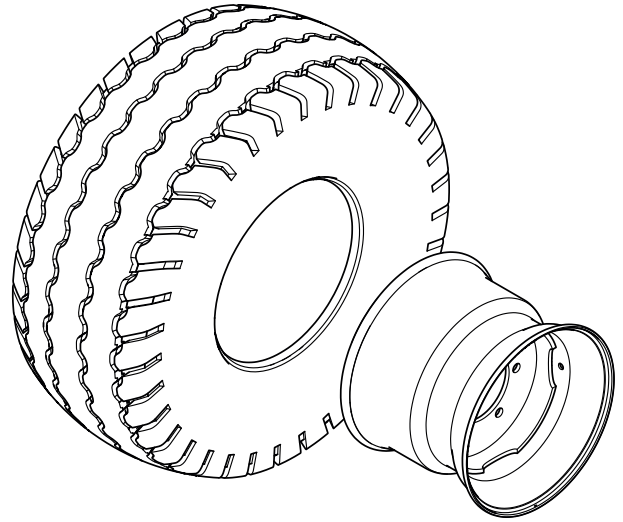

U.01-1

Table A.1. Tire assembly

Item	Tire	Rim	Pressure
1	385/65 R22.5 160K (160J)	11.75x22.5" Catalogue no. 225.1175.106P	800 kPa
2	445/45 R19.5 ET=-30 160J	14x19.5" Catalogue no. 195.14.15.6	800 kPa

