



PRONAR Sp. z o.o.

17-210 NAREW, UL. MICKIEWICZA 101A, PODLASKIE PROVINCE

tel.:	+48 085 681 63 29	+48 085 681 64 29
	+48 085 681 63 81	+48 085 681 63 82
fax:	+48 085 681 63 83	+48 085 682 71 10

www.pronar.pl

OPERATOR'S MANUAL

AGRICULTURAL TRAILER

PRONAR T023

TRANSLATION OF THE ORIGINAL COPY OF THE MANUAL

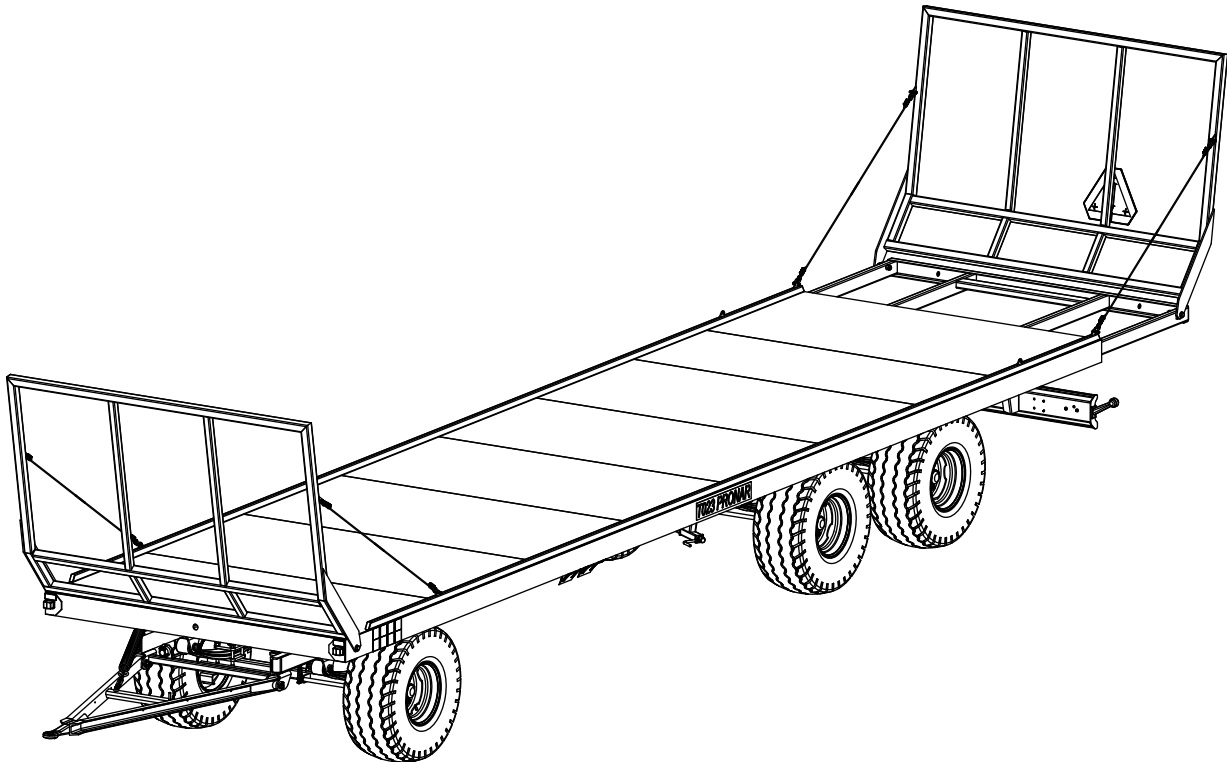

ISSUE 5B-01-2010

PUBLICATION NO 65N-00000000-UM



INTRODUCTION

Information contained herein is current at date of publication. As a result of improvements, some numerical values and illustrations contained in this publication may not correspond to the factual specification of the machine supplied to the user. The manufacturer reserves the right to introduce design changes in machines produced that facilitate operation and improve the quality of their work, without making minor amendments to this Operator's Manual. Please send your comments and proposals on the design and operation of the machine to the Manufacturer. This information enables objective evaluation of the machines produced and provides indications for their further improvement. Information on significant design changes is passed on to users on information inserts attached to this Operator's Manual (annexes). This Operator's Manual is an integral part of the machine's documentation. Before using the machine, the user must carefully read this Operator's Manual and observe all recommendations. This guarantees safe operation and ensures malfunction free work of the machine. The machine is designed to meet obligatory standards, documents and legal regulations currently in force.

The manual describes the basic safety rules and operation of agricultural trailer PRONAR T023. If the information contained in the Operator's Manual needs clarification then the user should refer for assistance to the sale point where the machine was purchased or to the Manufacturer.

Manufacturer's address:

PRONAR Sp. z o.o.

ul. Mickiewicza 101A

17-210 Narew

Contact telephones

+48 085 681 63 29 +48 085 681 64 29

+48 085 681 63 81 +48 085 681 63 82

Information, descriptions of danger and precautions and also recommendations and prohibitions associated with user safety instructions are marked:



and also preceded by the word "**DANGER**". Failure to observe the instructions may endanger the machine operator's or other person's health or life.

Particularly important information and instructions, the observance of which is essential, are distinguished in the text by the sign:



and also preceded by the word "**ATTENTION**". Failure to observe the instructions may lead to damage to the machine as a result of improper operation, adjustment or use.

In order to focus the user's attention on the need to perform maintenance, the relevant section of the Operator's Manual is marked with the pictogram:





PRONAR Sp. z o.o.

ul. Mickiewicza 101 A
17-210 Narew, Polska

tel./fax (+48 85) 681 63 29, 681 63 81, 681 63 82,
681 63 84, 681 64 29

fax (+48 85) 681 63 83

http://www.pronar.pl

e-mail: pronar@pronar.pl

EC DECLARATION OF CONFORMITY OF THE MACHINERY

PRONAR Sp. z o.o. declares with full responsibility, that the machine:

Description and identification of the machinery	
Generic denomination and function:	TRAILER
Type:	T023
Model:	-----
Serial number:	
Commercial name:	TRAILER PRONAR T023

to which this declaration relates, fulfills all the relevant provisions of the Directive **2006/42/EC** of The European Parliament and of The Council of 17 May 2006 on machinery, and amending Directive 95/16/EC (Official Journal of the EU, L 157/24 of 09.06.2006).

The person authorized to compile the technical file is the Head of Research and Development Department at PRONAR Sp. z o.o., 17-210 Narew, ul. Mickiewicza 101A, Poland.

This declaration relates exclusively to the machinery in the state in which it was placed on the market, and excludes components which are added and/or operations carried out subsequently by the final user.

Narew, the _____

Place and date

Z-CA DYREKTORA
d/s technicznych
członek zarządu

Roman Gniński

*Full name of the empowered person
position, signature*

TABLE OF CONTENTS

1. INTRODUCTION	1.1
1.1 IDENTIFICATION	1.2
1.2 PROPER USE	1.3
1.3 EQUIPMENT	1.5
1.4 WARRANTY TERMS.....	1.5
1.5 TRANSPORT.....	1.7
1.6 ENVIRONMENTAL HAZARDS.....	1.8
1.7 WITHDRAWAL FROM USE	1.9
2. SAFETY ADVICE	2.1
2.1 BASIC SAFETY RULES	2.2
2.2 DRIVING ON PUBLIC ROADS.....	2.6
2.3 DESCRIPTION OF MINIMAL RISK	2.7
2.4 INFORMATION AND WARNING DECALS.....	2.8
3. DESIGN AND OPERATION	3.1
3.1 TECHNICAL SPECIFICATION	3.2
3.2 TRAILER CONSTRUCTION.....	3.3
3.3 MAIN BRAKE.....	3.5
3.4 PARKING BRAKE	3.9
3.5 ELECTRICAL SYSTEM, WARNING SIGNS AND INDICATORS.....	3.9
4. CORRECT USE	4.1
4.1 PREPARING FOR WORK BEFORE FIRST USE.....	4.2
4.2 CHECKING TECHNICAL CONDITION	4.2
4.3 HITCHING TO TRACTOR	4.4
4.4 DISCONNECTING FROM TRACTOR.....	4.8
4.5 PROPER USE AND MAINTENANCE OF TYRES.....	4.8
5.1 MAINTENANCE	5.1
5.1 CHECKING AND ADJUSTMENT OF WHEEL AXLE BEARINGS.....	5.2
5.2 ADJUSTMENT OF MAIN BRAKES	5.3
5.3 ADJUSTMENT OF MAIN BRAKES	5.5

5.4	PNEUMATIC SYSTEM OPERATION	5.6
5.5	HYDRAULIC SYSTEM OPERATION	5.7
5.6	LUBRICATION.....	5.9
5.7	ABSORBER SPRING SYSTEM MAINTENANCE.....	5.10
5.8	STORAGE	5.10
5.9	ADJUSTING DRAWBAR TO MATCH TRACTOR HITCH.....	5.12
5.10	TIGHTENING TORQUE FOR NUT AND BOLT CONNECTIONS	5.12
5.11	TROUBLESHOOTING	5.14
5.12	LIST OF BULBS.....	5.14

SECTION

1

BASIC INFORMATION

IDENTIFICATION

PROPER USE

EQUIPMENT

WARRANTY TERMS

TRANSPORT

ENVIRONMENTAL HAZARDS

WITHDRAWAL FROM USE

1.1 IDENTIFICATION

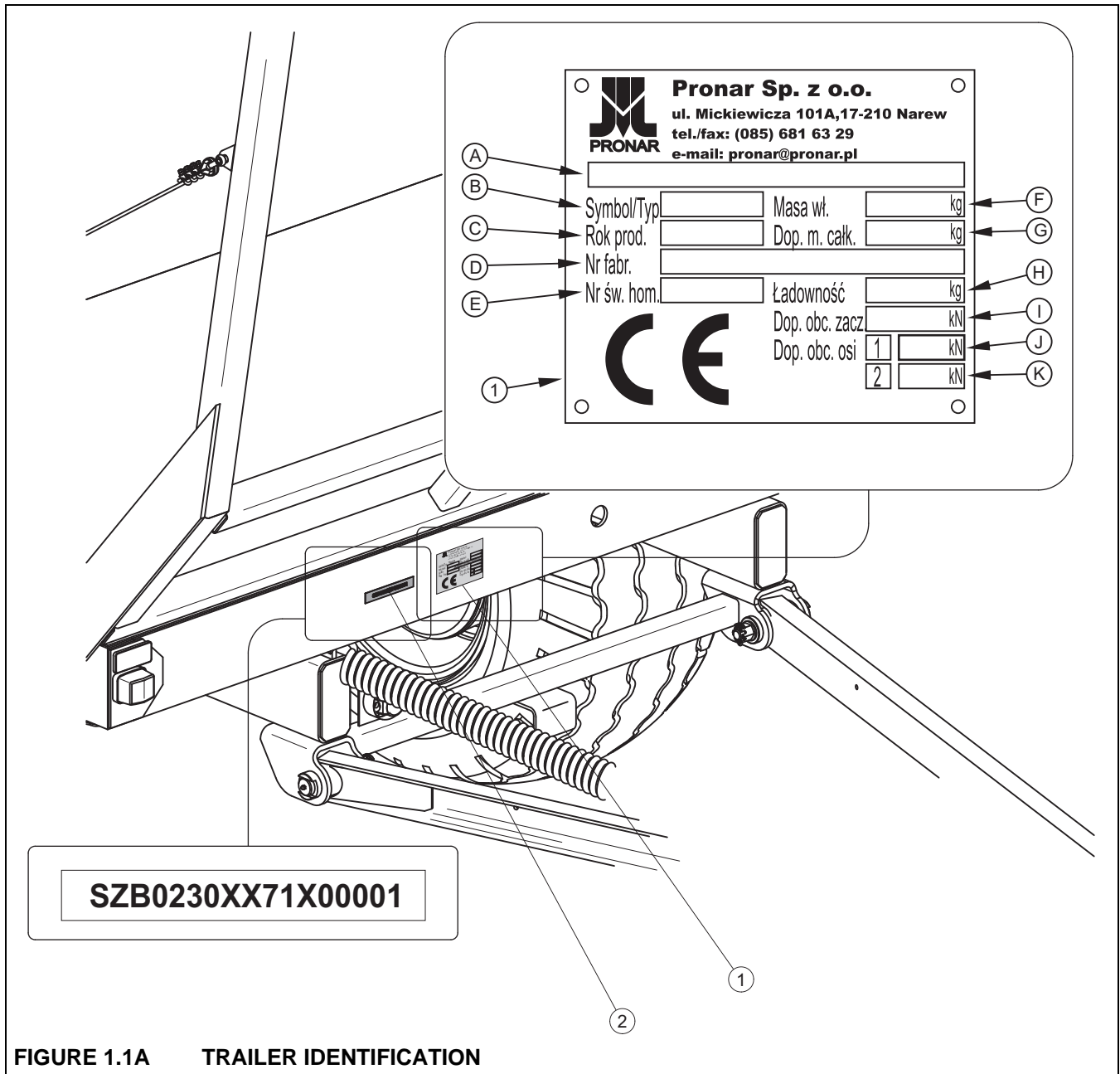

FIGURE 1.1A TRAILER IDENTIFICATION

(1) data plate, (2) serial number

The trailer has a data plate located on the front beam of the frame. The factory number is stamped into the data plate and into a rectangle area painted silver located on the left side of the front beam of the frame. When buying the trailer check that the serial numbers on the machine agree with the number written in the *WARRANTY BOOK* , in the sales documents and in the *OPERATOR'S MANUAL*..

The meanings of the individual fields found on the data plate are presented in the table below:

TABLE 1.1 MARKINGS ON DATA PLATE

ITEM	MARKING
A	General description and purpose
B	Symbol /Type
C	Year of manufacture
D	Seventeen digit serial number (VIN)
E	Official certificate number
F	Tare weight
G	Maximum gross weight
H	Carrying capacity
I	Permissible hitching system loading
J	Permissible front axle load
K	Permissible rear axle load

The factory number of the axle and its type are stamped onto the data plate secured to the axle beam.

1.2 PROPER USE

The trailer is designed for transport of harvested crops and agricultural products in the form of pressed bales or blocks, at the farm and on public roads. The machine is also designed for transport of harvested crops and agricultural products transported on pallets.

TABLE 1.2 RECOMMENDED TYPES OF PALLETS

PALLET NAME AND SITE	LENGTH [mm]	WIDTH [mm]	HEIGHT [mm]
EUR – standard	1,200	800	144

PALLET NAME AND SITE	LENGTH [mm]	WIDTH [mm]	HEIGHT [mm]
EUR – 1/2	800	600	144
EUR – extended	1,200	1,200	144
ISO	1,200	1,000	144

The brake system and the light and indicator system meet the requirements of road traffic regulations. The maximum speed of the trailer on public roads is 30 km/h in Poland (pursuant to Road Traffic Act of June 20th 1997, art. 20). In the countries where the trailer is used, the limits stipulated by the road traffic legislation in force in a given country must be observed. The trailer's speed must not, however, be greater than the maximum design speed of 40 km/h.

DANGER



The trailer must not be used for purposes other than those for which it is intended, in particular:

- for transporting people and animals,
- for transporting any materials other than those stipulated in the manual.

Axle system (axles, leaf springs, wheels and tyres), meet the requirements for agricultural machines. The fulfilment of these requirements is conditioned by proper operation and the adherence to the principles included in this *OPERATOR'S MANUAL*.

The trailer is designed for use with agricultural tractors that are equipped with 12V electric lighting system (with a 7-pole socket) and with upper transport hitch. Depending on brake system version installed in the trailer, the tractor must be equipped with one of the following brake systems:

- single conduit pneumatic brake system,
- double conduit pneumatic brake system,
- Hydraulic brake system



ATTENTION!

The hydraulic brake system is filled with HL32 hydraulic oil.

1.3 EQUIPMENT

The standard equipment of each trailer includes:

- *OPERATOR'S MANUAL*,
- *WARRANTY BOOK*,
- Connection lead for the electrical system
- Wheel chocks.

On request, the Manufacturer may equip the trailer with the following additional equipment:

- Slow-moving vehicle warning sign
- Warning reflective triangle.

1.4 WARRANTY TERMS

PRONAR Sp. z o.o., Narew guarantees the reliable operation of the machine when it is used according to its intended purpose as described in the *OPERATOR'S MANUAL*.

The repair period is specified in the *WARRANTY BOOK*.

The guarantee does not apply to those parts and sub-assemblies of the machine, which are subject to wear in normal usage conditions, regardless of the warranty period. Consumables include the following parts/sub-assemblies:

- drawbar hitching eye,
- pneumatic system connector filters,
- tyres,
- brake shoes,
- bulbs and LED lamps,
- seals,

- bearings.

The warranty service only applies to such cases as: mechanical damage, which is not the user's fault, factory defects of parts, etc.

In the event of damage arising from:

- mechanical damage which is the user's fault, caused by road accidents,
- by inappropriate use, adjustment or maintenance, use of the trailer for purposes other than those for which it is intended,
- use of damaged machine,
- repairs carried out by unauthorised persons, improperly carried out repairs,
- making unauthorised alterations to machine design,

the user will lose the right to warranty service.



TIP

Demand that the seller carefully and precisely fills out the *Warranty Book* and guarantee repair coupons. A missing date of purchase or sale point stamp, may make the user ineligible for any warranty repair or refund.

The user is obliged to report immediately on noticing any wear in the paint coating or traces of corrosion, and to have the faults rectified whether they are covered by the guarantee or not. Detailed guarantee regulations are contained in the *WARRANTY BOOK* attached to each machine.

Modification of the trailer without the written consent of the Manufacturer is forbidden. In particular, do NOT weld, drill holes in, cut or heat the main structural elements of the machine, which have a direct impact on the machine operation safety.

1.5 TRANSPORT

The trailer is ready for sale completely assembled and does not require packing. Packing is only required for the machine's technical documentation and any extra fittings.

DANGER



When transporting independently, the user must carefully read this Operator's Manual and observe all recommendations. When being transported on a motor vehicle the trailer must be mounted on the vehicle's platform in accordance with the transport safety requirements. The driver of the vehicle should take particular care while transporting the trailer. This is due to the vehicle's centre of gravity shifting upwards when loaded with the machine.

The trailer is delivered to the user either transported on a vehicle or, independently (towed), after being attached to a tractor.

When loading and unloading the trailer, comply with the general principles of workplace health and safety for reloading work. Persons operating reloading equipment must have the qualifications required to operate these machines.

The trailer should be attached firmly to the platform of the vehicle using straps or chains fitted with a tightening mechanism. The fastening equipment used must have a valid safety certificate. Chocks or other objects without sharp edges should be placed under the wheels of the trailer to prevent it from rolling. The chocks must be fixed to the platform of the vehicle. During reloading work, particular care should be taken not to damage parts of the trailer's fittings or the lacquer coating. Belts and/or chains should be attached to transport lugs (1) (location of the lugs on the left side of the trailer is shown on figure (1.2A), or to other permanent elements of the trailer (longitudinal members, crossbars etc.). Particular care should be taken not to damage the machine. Belts and/or chains should be attached securely enough to guarantee safe transport.

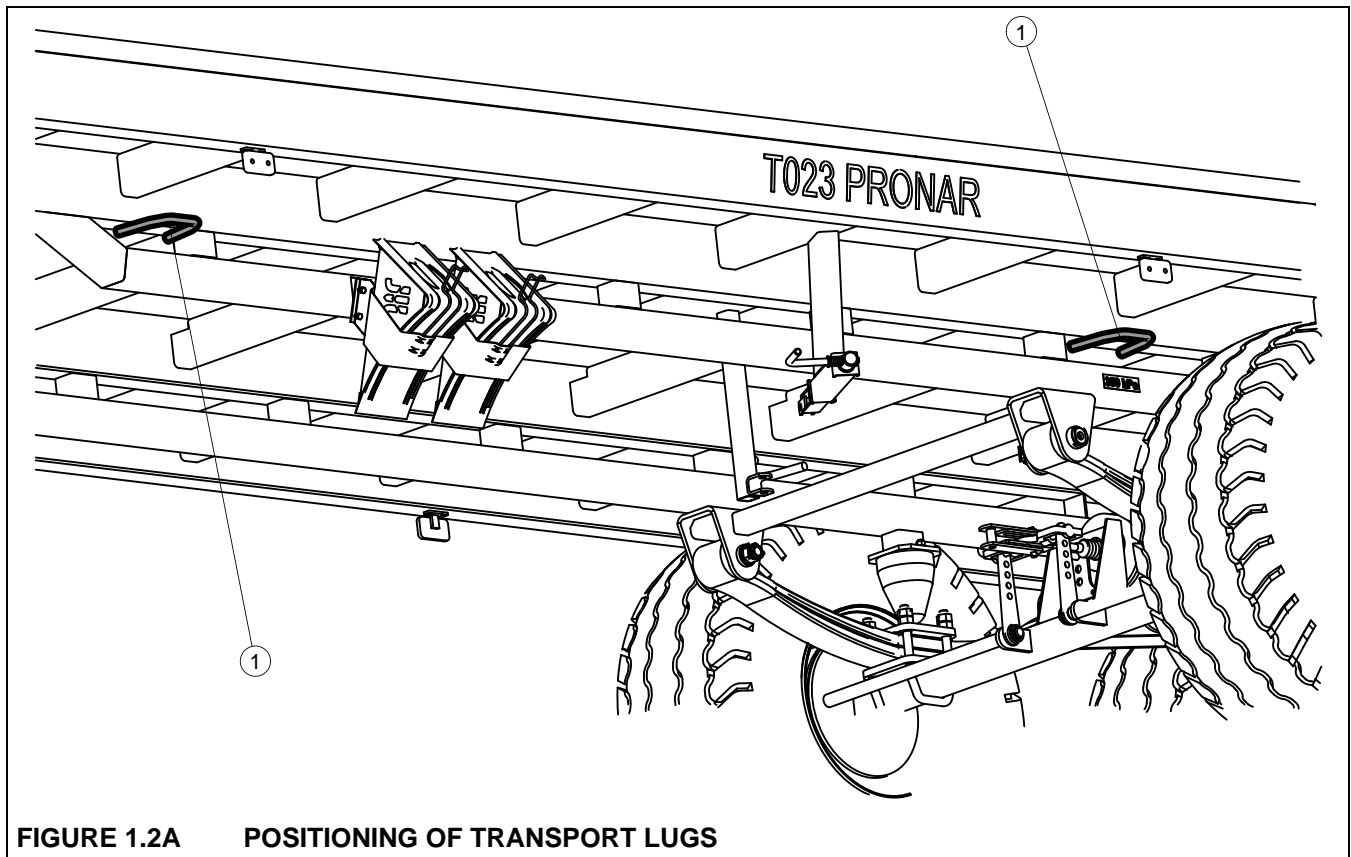

FIGURE 1.2A POSITIONING OF TRANSPORT LUGS

(1) transport lug

1.6 ENVIRONMENTAL HAZARDS

A hydraulic oil leak (from hydraulic brake system) constitutes a direct threat to the natural environment owing to its limited biodegradability. The negligible solubility of hydraulic oil in water does not cause extreme toxicity of organisms living in the aquatic environment. The formation of a film of oil on the water may be the direct cause of physical action on organism, perhaps causing change of oxygen values in the water because of lack of direct contact of air with the water. An oil leak into water reservoirs may however lead to a reduction of the oxygen content.

While carrying out maintenance and repair work, which involves the risk of an oil leak, this work should take place on an oil resistant floor or surface. In the event of oil leaking into the environment, first of all contain the source of the leak, and then collect the leaked oil using available means. Remaining oil should be collected using sorbents, or by mixing the oil with sand, sawdust or other absorbent materials. The oil pollution, once gathered up, should be kept in a sealed, marked, hydrocarbon resistant container. The container should be kept away from heat sources, flammable materials and food.



DANGER

Used hydraulic oil or gathered remains mixed with absorbent material should be stored in a precisely marked container. Do not use food packaging for this purpose.

Oil, which has been used up or is unsuitable for further use owing to a loss of its properties should be stored in its original packaging in the conditions described above. Waste oil should be taken to the appropriate facility dealing with the re-use of this type of waste. Waste code: 13 01 10. Detailed information concerning hydraulic oil may be found on the product's Material Safety Data Sheet.



TIP

The hydraulic system of the trailer is filled with L-HL32 Lotos hydraulic oil.



IMPORTANT!

Waste oil should only be taken to the appropriate facility dealing with the re-use of this type of waste. Do NOT throw or pour oil into sewerage or water tanks.

1.7 WITHDRAWAL FROM USE

In the event of decision by the user to withdraw the trailer from use, comply with the regulations in force in the given country concerning withdrawal from use and recycling of machines withdrawn from use. Before commencing dismantling, totally remove the oil from the hydraulic system and reduce air pressure completely in the pneumatic brake system (e.g. using air tank drain valve).



DANGER

During dismantling use the appropriate tools, equipment (overhead travelling crane, crane or hoist etc.), using personal protection equipment, i.e. protective clothing, footwear, gloves and eye protection etc.

Avoid contact of skin with oil. Do not allow used hydraulic oil to spill.

Worn out or damaged parts that cannot be reclaimed should be taken to a collection point for recyclable raw materials. Hydraulic oil should be taken to the appropriate facility dealing with the re-use of this type of waste.

SECTION

2

SAFETY ADVICE

BASIC SAFETY RULES

DRIVING ON PUBLIC ROADS

DESCRIPTION OF MINIMAL RISK

INFORMATION AND WARNING DECALS

2.1 BASIC SAFETY RULES

- Before using the trailer, the user must carefully read this operator's manual. When operating the machine, the operator must comply with the recommendations. The trailer may only be used and operated by persons qualified to drive agricultural tractors and trained in the use of the machine.
- If the information contained in the *OPERATOR'S MANUAL* is difficult to understand, contact a seller who runs an authorised technical service on behalf of the Manufacturer, or contact the Manufacturer directly.
- Careless and improper use and operation of the trailer, and non-compliance with the recommendations given in this operator's manual is dangerous to your health.
- Be aware of the existence of a minimal risk, and for this reason the fundamental basis for using this machine should be the application of safety rules and sensible behaviour.
- The trailer must never be used by persons, who are not authorised to drive agricultural tractors, including children and people under the influence of alcohol or other drugs.
- Non-compliance with the safety rules of this Operator's Manual can be dangerous to the health and life of the operator and others.
- The trailer must not be used for purposes other than those for which it is intended. Anyone who uses the machine other than the way intended takes full responsibility for himself for any consequences of this use. Use of the trailer for purposes other than those for which it is intended by the Manufacturer (see section (1.2)) is not in accord with the trailer design and may invalidate the guarantee.
- Any modification to the bale trailer frees PRONAR Narew from any responsibility for damage or detriment to health, which may arise as a result.
- The trailer can only be stood on when it is absolutely motionless and the tractor engine is switched off. Use safe and resistant platforms or ladders of proper height.
- In the event of failure of the braking system, do not use the trailer until the malfunction is corrected.
- The trailer unhitched from tractor must be immobilised with parking brake. If the machine is positioned on a slope or elevation it shall be additionally secured against

moving by placing chocks or other objects without sharp edges under the trailer's wheels.

- People or animals must not be carried.
- The trailer and tractor must not be attached if the hydraulic oil in the two machines is of different types (applies to trailer version with hydraulic braking system) – compare table (5.4).
- The machine must not be used when not in working order.
- Do NOT exceed the trailer's maximum carrying capacity. Exceeding the carrying capacity may lead to damage to the machine, loss of stability while driving, scattering of the load and danger while working or driving.
- Before each use of the trailer, check the technical condition of the trailer and tractor hitching system and connection elements of the braking system and electrical system.
- Exercise caution when connecting and disconnecting machine from the tractor.
- When hitching, there must be nobody between the trailer and the tractor.
- When hitching the trailer to the tractor only the upper transport hitch should be used. Check safety clips.
- If the trailer is equipped with the hitching system for coupling second trailer, the extendible frame should be retracted before coupling second trailer.
- Load on the trailer must be uniformly distributed.
- Keep a safe distance during loading and unloading. Do not allow anyone to approach the place where works are carried out.
- Load should be protected against moving by means of belts, chains and tapes or other securing measures. The securing measures must be fitted with a tightening mechanism and have proper safety certificates.
- When operating, the air tank and hydraulic brake system are under high pressure.
- Check the condition of braking system frequently. Oil leaks in the system are not allowed.
- Regularly check the technical condition of the connections and the pneumatic and hydraulic conduits.

- When connecting the hydraulic conduits to the tractor, make sure that the tractor and bale trailer hydraulic system are not under pressure.
- Before beginning repair or maintenance works on pneumatic or hydraulic systems reduce air or oil pressure.
- In the event of injuries being caused by pressurised hydraulic oil, contact a doctor immediately. Hydraulic oil may find its way under the skin and cause infections.
- Use the hydraulic oil recommended by the Manufacturer. Never mix two types of oil.
- After changing the hydraulic oil, the used oil should be properly disposed of.
- Do not make independent repairs of control valve, brake cylinders and braking force regulator. In the event of damage to these elements, repair should be entrusted to authorised service point or replace elements with new parts.
- When working on the tyres, chocks or other objects without sharp edges should be placed under the wheels of the trailer to prevent it from rolling. Wheels can be taken off the trailer axle only when the trailer is not loaded.
- The paint coating should be cleaned off before beginning welding work. Burning paint fumes are poisonous for people and animals. Welding work should be carried out in a well lit and well ventilated space.
- During welding work pay attention to flammable and fusible elements (parts of the hydraulic, pneumatic and electric systems, plastic and rubber parts). If there is a risk that they will catch fire or be damaged, they should be removed before commencing welding work.
- Repair work on the wheels or tyres should be carried out by persons trained and entitled to do so. This work should be carried out using appropriate tools.
- After removing a wheel, always check how firmly the nuts are screwed in. Individual checks should be made after the first use, after the first journey with a load, after travelling 1000 km and then every 6 months. The above actions should be repeated individually if a wheel has been removed from the wheel axle.
- Check the tyre pressure regularly.
- In the event of any fault or damage whatsoever, do not use the trailer until the fault has been fixed. The trailer must not be used when not in working order.

- When operating the machine wear protective gloves and close fitting clothing and use the appropriate tools.
- Servicing and repair work should be carried out in line with the general principles of workplace health and safety. In the event of injury, the wound must be immediately cleaned and disinfected. In the event of more serious injuries, seek a doctor's advice.
- Repair, maintenance and cleaning work should be carried out with the tractor's engine switched off and the ignition key removed.
- Regularly check the condition of the bolt and nut connections.
- Before welding or electrical work, the trailer should be disconnected from the power supply.
- During the warranty period, any repairs may only be carried out by Warranty Service authorised by the manufacturer.
- Should it be necessary to change individual parts, use only original parts. Non-adherence to these requirements may put the user and other people's health and life at risk, and also damage the machine and invalidate the guarantee.
- In the event of work requiring the trailer to be raised, use properly certified hydraulic or mechanical lifts for this purpose. After lifting the trailer, stable and durable supports must also be used. Work must not be carried out under a trailer, which has only been raised with a lift or jack.
- The trailer must not be supported using fragile elements (bricks or concrete blocks).
- After completing work associated with lubrication, remove excess oil or grease.
- Use appropriate tools, close-fitting protective clothing and gloves when operating, maintaining or cleaning the machine.

2.2 DRIVING ON PUBLIC ROADS

- While driving on public roads the trailer shall be marked with a warning triangle distinguishing slow-moving vehicles. The warning triangle should be attached to the rear ladder.
- Comply with the road traffic regulations.

- Exceeding the maximum load capacity of the trailer may damage it, and also threaten the safety of traffic.
- Do not exceed the maximum speed limit. Adjust your speed to the road conditions.
- The trailer must NOT be left unsecured. Securing the trailer involves immobilising the trailer with the parking brake and, optionally, placing chocks under trailer wheels.
- While driving on public roads the trailer must be fitted with a certified or authorised reflective warning triangle.
- Do not drive on public roads with extended frame.

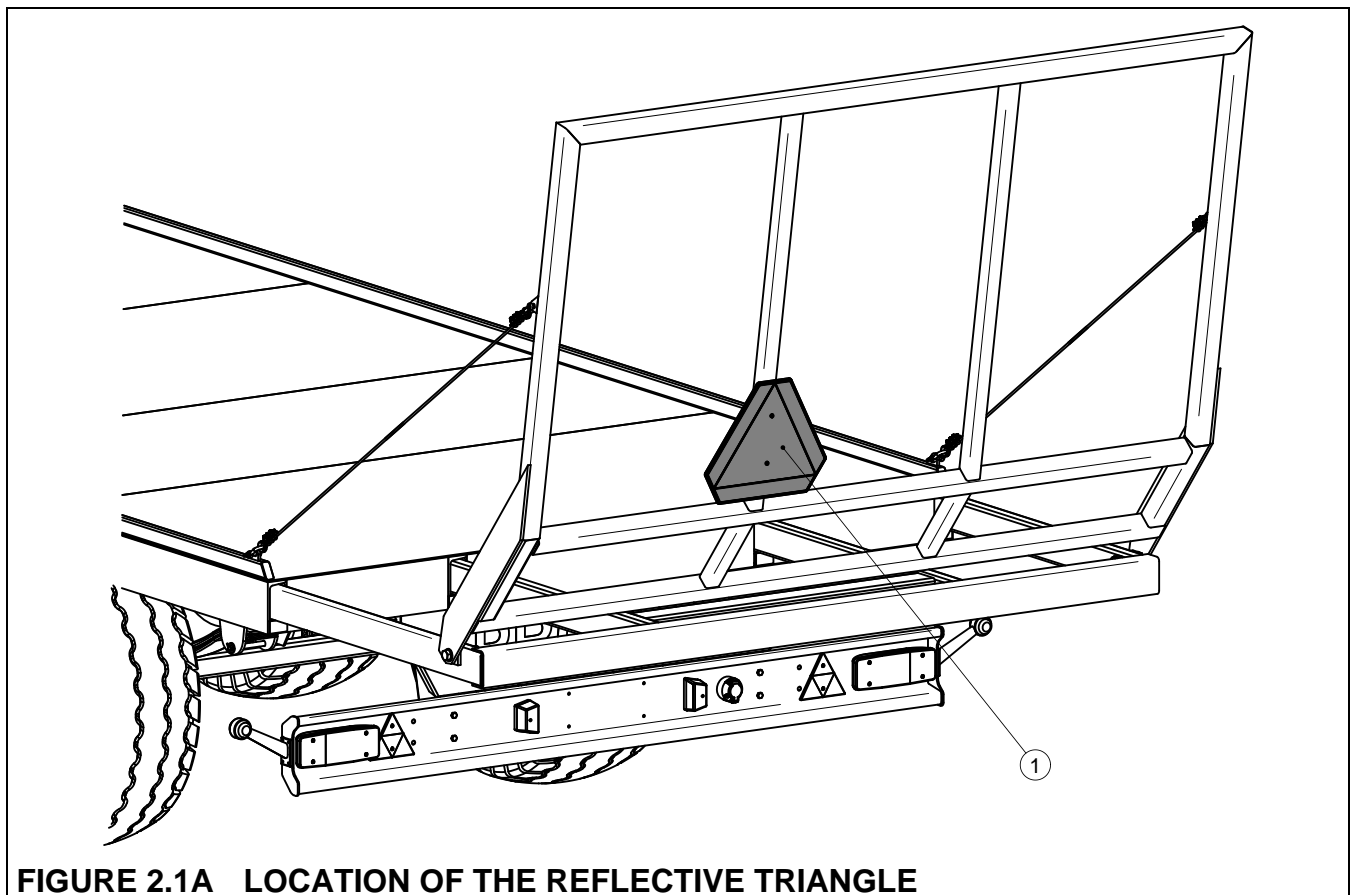

FIGURE 2.1A LOCATION OF THE REFLECTIVE TRIANGLE

(1) slow moving vehicle reflective warning triangle

2.3 DESCRIPTION OF MINIMAL RISK

Pronar Sp. z o. o. in Narew has made every effort to eliminate the risk of accidents. There is, however, a certain minimal risk, which could lead to an accident, and this is connected mainly with the actions described below:

- using trailer for purposes other than those described in the Operator's Manual,

- being between the tractor and the trailer while the engine is working and when the machine is being attached,
- operation of the trailer by persons under the influence of alcohol or other intoxicating substances,
- operation of the trailer by unauthorised persons,
- being on the machine during work,
- careless cleaning, maintenance and technical checks of the trailer.



The minimal risk may be kept to a minimum by following the recommendations below:

- prudent and unhurried operation of the machine,
- sensible application of the remarks and recommendations contained in the *OPERATOR'S MANUAL*,
- maintaining safe distance from forbidden or dangerous places,
- a ban on being on the machine when it is operating,
- carrying out repair and maintenance work by persons trained to do so,
- using close fitting protective clothing,
- ensuring unauthorised persons have no access to the machine, especially children.

2.4 INFORMATION AND WARNING DECALS

The trailer is labelled with the information and warning decals mentioned in table (2.1). The symbols are positioned as presented in figure (2.2A). Throughout the time it is in use, the user of the machine is obliged to take care that notices and warning and information symbols located on the trailer are clear and legible. In the event of their destruction, they must be replaced with new ones. Safety decals are available from your PRONAR dealer or directly from PRONAR customer service. New assemblies, changed during repair, must be labelled once again with the appropriate safety signs.

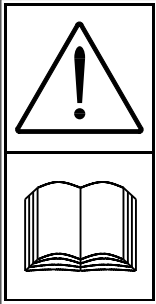
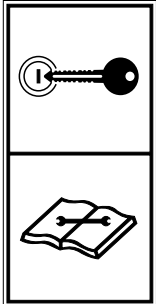
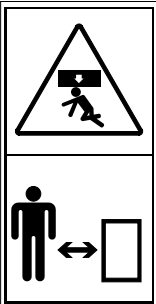
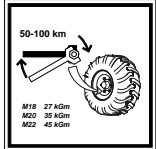
TABLE 2.1 INFORMATION AND WARNING DECALS

ITEM	SYMBOL	MEANING OF SYMBOL
1		<p>Before starting work, carefully read the <i>OPERATOR'S MANUAL</i>.</p>
2		<p>Switch off engine and remove key from ignition prior to servicing or repairs,</p>
3		<p>Keep a safe distance. Danger of crushing by the drawbar and protective ladders.</p>
4		<p>Check the condition of the screw and nut connections of the wheel axles regularly</p>
5		<p>Grease according to the recommendations in the <i>OPERATOR'S MANUAL</i></p>
6	<div style="border: 1px solid black; padding: 5px; display: inline-block;">350 kPa</div>	<p>Air pressure in the tyres★</p>
7	<div style="border: 1px solid black; padding: 5px; display: inline-block;">T023 PRONAR</div>	<p>Trailer name</p>

★ - tyre pressure in standard fittings, pressure levels may be subject to change depending on the tyres used

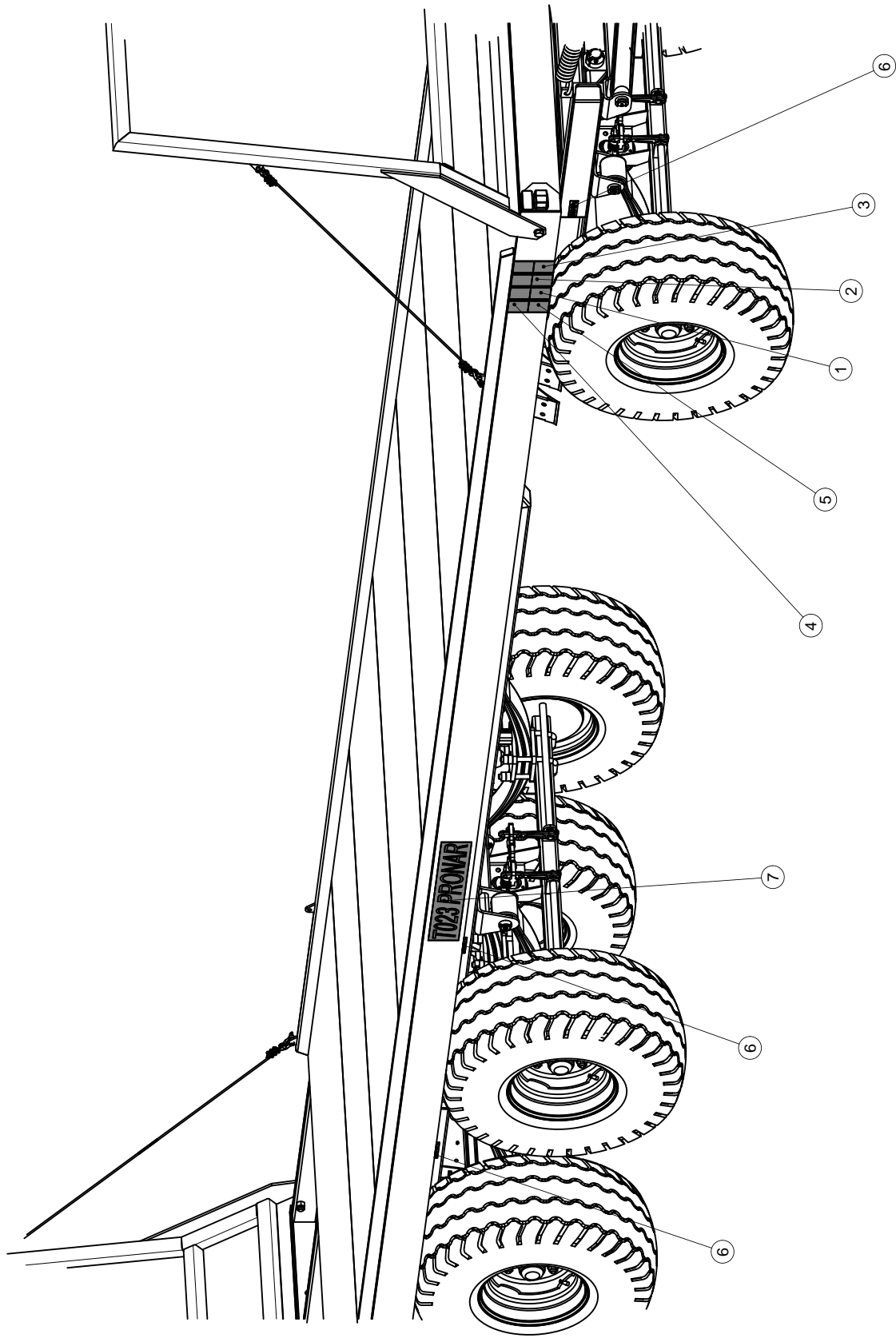

FIGURE 2.2A SYMBOL LOCATIONS

Markings on the figure are according to table 2.1 "Information and warning decals"

SECTION

3

DESIGN AND OPERATION

TECHNICAL SPECIFICATION

TRAILER CONSTRUCTION

MAIN BRAKE

PARKING BRAKE

ELECTRICAL SYSTEM, WARNING SIGNS AND INDICATORS

3.1 TECHNICAL SPECIFICATION

TABLE 3.1 BASIC TECHNICAL SPECIFICATION OF THE TRAILER

CONTENTS	UNIT	T023
Dimensions		
Length		
- with extended rear frame	mm	13,170
- with retracted rear frame	mm	11,995
Width	mm	2,500
Height	mm	2,800
Load box dimensions		
Length of load surface		
- with extended rear frame	mm	10,770
- with retracted rear frame	mm	9,880
Width	mm	2,450
Technical specification		
Maximum design carrying capacity	kg	11,300
Maximum gross weight	kg	15,000
Tare weight	kg	3,700
Height of platform from ground	mm	1,100
Tyres		
Tyre dimensions	-	400/60-15.5 14PR 145A8
Wheel rim size	-	13.00 x 15.5
Air pressure in the tyres	kPa	350★
Other information		
Electrical system voltage	V	12
Axle track	mm	1,730
Maximum design speed	km/h	40 (30★★)
Tractor power demand	hp/kW	83.2 / 61

* - tyre pressure in standard fittings, pressure levels may be subject to change depending on the tyres used

** - The maximum speed of the trailer on public roads is 30 km/h in Poland (pursuant to Road Traffic Act of June 20th 1997, art. 20). In the countries where the trailer is used, the limits stipulated by the road traffic

legislation in force in a given country must be observed. The trailer's speed must not, however, be greater than the maximum design speed of 40 km/h.

3.2 TRAILER DESIGN

The trailer design is presented on figures (3.1A), (3.2A) and (3.3A). Frame (1) of the load box is a structure welded from steel sections. The main support elements are longitudinal members connected with crossbars. Load platform is limited by means of ladders (2) and (3) (the front part of the platform is secured to frame (1) and the rear part of the platform is secured to extendible frame (4)). The ladders are protected against excessive deflection with steel cables (6). The bolt mechanism of the parking brake is welded underneath, on the left side of the frame.

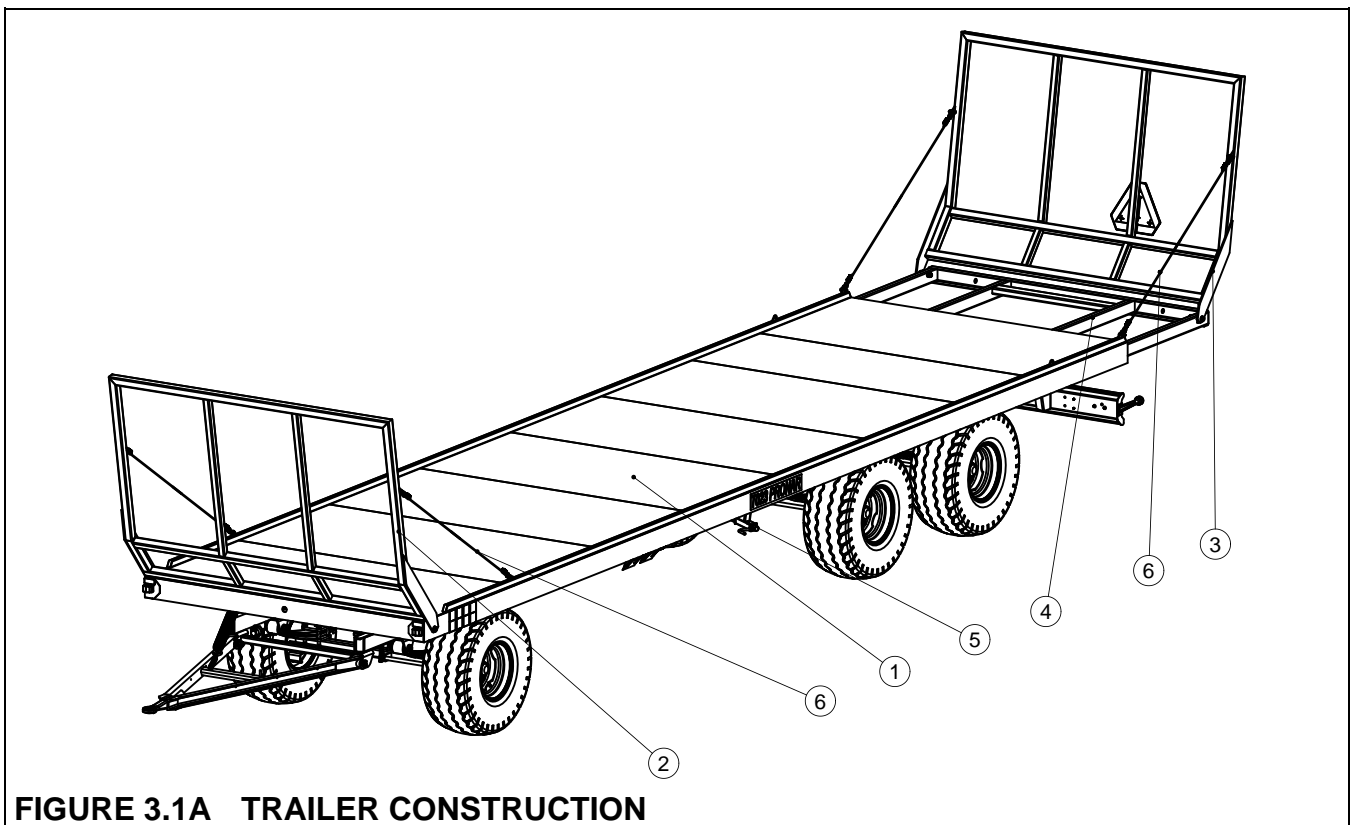

FIGURE 3.1A TRAILER CONSTRUCTION

(1) frame – load platform, (2) front ladder, (3) rear ladder, (4) extendible frame, (5) parking brake mechanism, (6) linking cable

In the front part of the trailer there are front axle suspension elements: rotator (8), rotator frame (7), taper leaf springs (11) and drawbar (10).

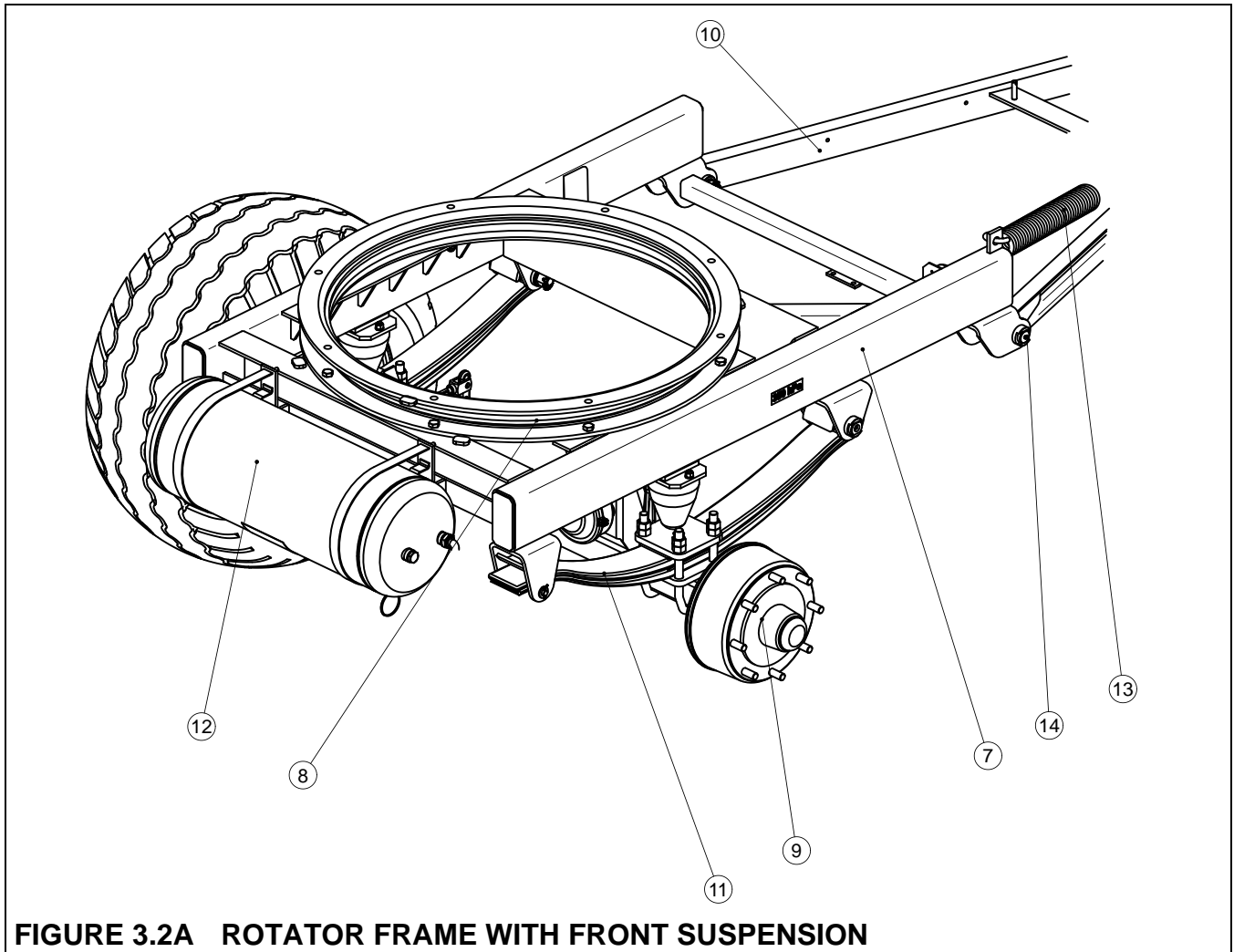

FIGURE 3.2A ROTATOR FRAME WITH FRONT SUSPENSION

(7) rotator frame, (8) rotator, (9) wheel axle, (10) drawbar, (11) taper leaf spring, (12) air tank, (13) spring, (14) drawbar pin

Drawbar is fixed to the turntable frame using pins (14). The height of drawbar attachment can be adjusted by moving the bracket fixing the spring to the drawbar. In the rear part of the frame there is a tandem wheel assembly with absorber spring suspension and elements of the rear light assembly.

Front axle and rear axles are made from rectangular rod terminated with pins, on which on cone bearings are mounted wheel hubs. The wheels are single, equipped with brake shoes activated through mechanical expander cams.

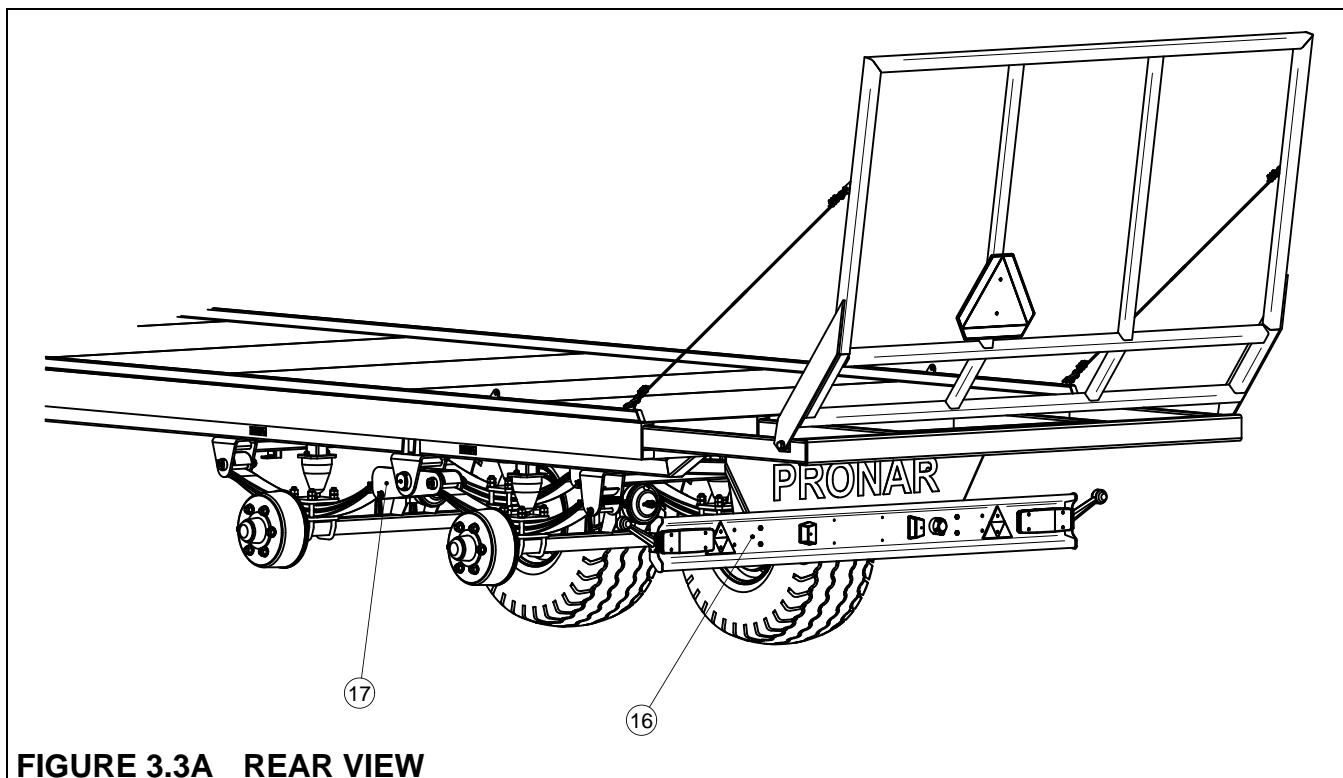

FIGURE 3.3A REAR VIEW

(16) lights support beam, (17) rocker arm

3.3 MAIN BRAKE

Depending on the version, the trailer is equipped with one of the three types of working brake system:

- single conduit pneumatic system with three position regulator, figure (3.4 A),
- double conduit pneumatic brake system **three position regulator** - figure (3.5A),
- hydraulic system - figure (3.7A).

Working brake is activated from the tractor driver's seat by pressing on the brake pedal in the tractor. The control valve activates the trailer brakes when the brake pedal is pressed in the tractor. Furthermore, in case of an inadvertent disconnection of the connection conduit in the pneumatic systems, between the trailer and the tractor, the control valve will automatically activate the machine brakes. Valve used in the system is equipped with a circuit causing the brakes to be applied when trailer is disconnected from the tractor. When compressed air conduit is connected to the tractor, the device automatically applying the brakes now changes its position to allow normal brake operation.

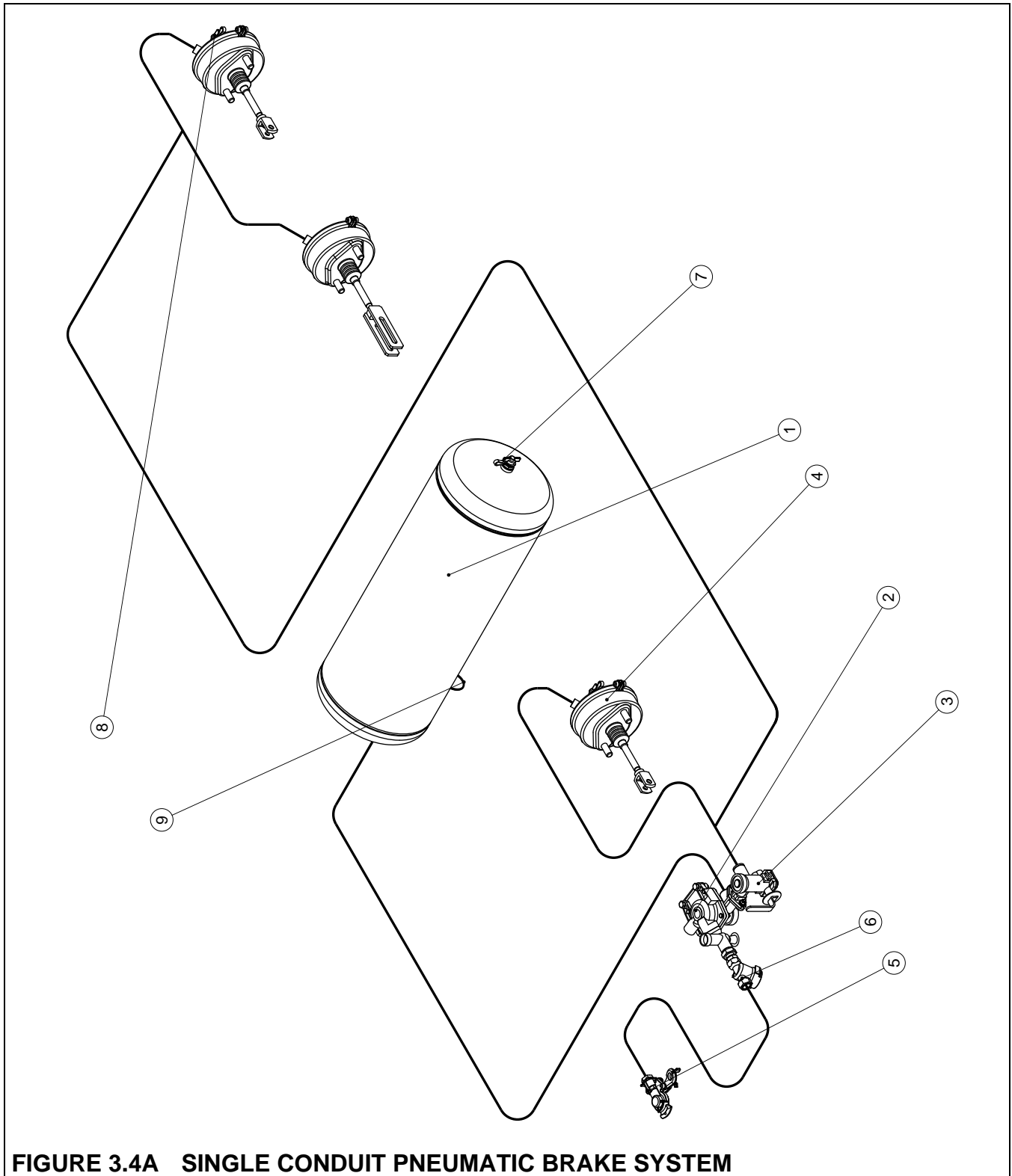

(1) air tank, (2) control valve, (3) brake force regulator, (4) pneumatic cylinder, (5) connector, (6) air filter, (7) air tank control connector, (8) pneumatic cylinder control connector, (9) drain valve

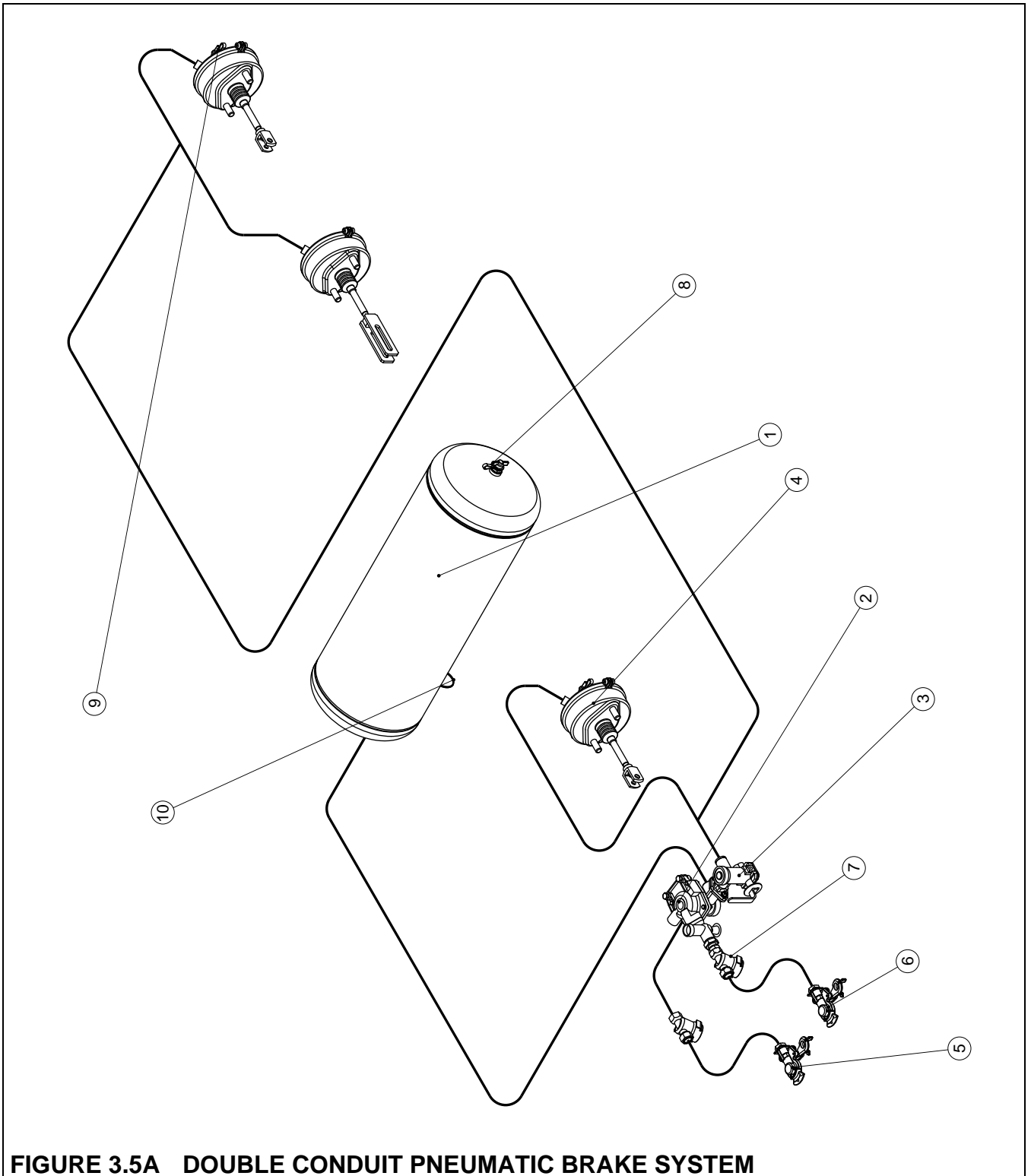

FIGURE 3.5A DOUBLE CONDUIT PNEUMATIC BRAKE SYSTEM

(1) air tank, (2) control valve, (3) braking force regulator, (4) pneumatic cylinder, (5) conduit connector (red), (6) conduit connector (yellow), (7) air filter, (8) air tank control connector, (9) pneumatic cylinder control connector, (10) drain valve

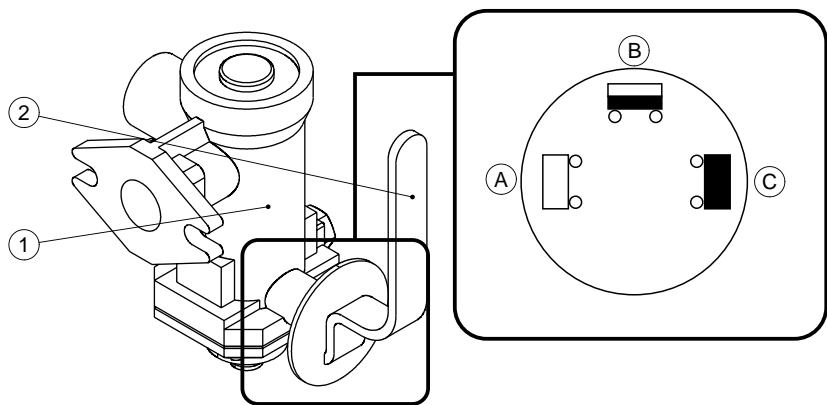

FIGURE 3.6A THREE-STEP BRAKING FORCE REGULATOR

(1) braking force regulator, (2) lever, (a) "no load" (b) "half load", (c) "full load"

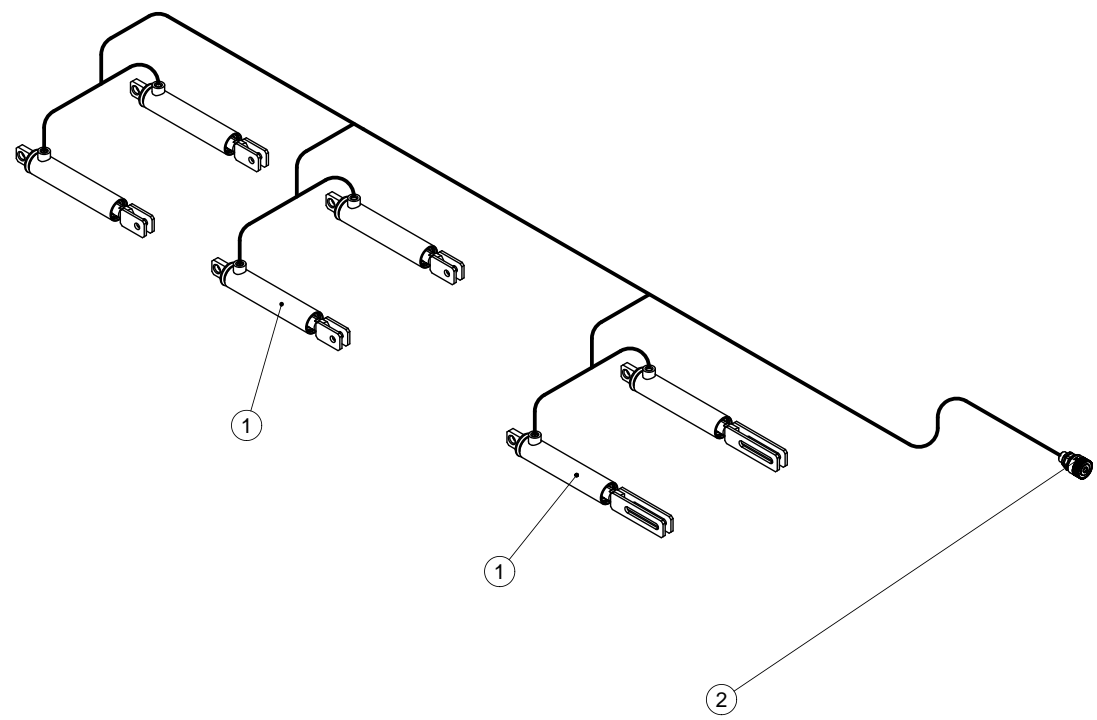

FIGURE 3.7A HYDRAULIC BRAKE SYSTEM

(1) hydraulic brake cylinder, (2) supply conduit connector

Three-step brake force regulator (figure (3.6A) in pneumatic system adjusts braking force depending on the regulator's setting. Switching to a suitable working mode is done manually by trailer operator using the regulator lever prior to moving off. The regulator has 3 working positions: "no load", "half load", "full load". The maximum braking force is obtained in "full load" working position.

3.4 PARKING BRAKE

The parking brake is for immobilising trailer while standing motionless. The brake crank mechanism, located on the left side of the frame, is connected with the axle expander levers using a steel cable. Rotation of the crank increases tension of the steel cable. Expander arms exert pressure on brake shoes and cause the axle to brake. Prior to moving off, handbrake must be released - steel cable must hang loose.

3.5 ELECTRICAL SYSTEM, WARNING SIGNS AND INDICATORS

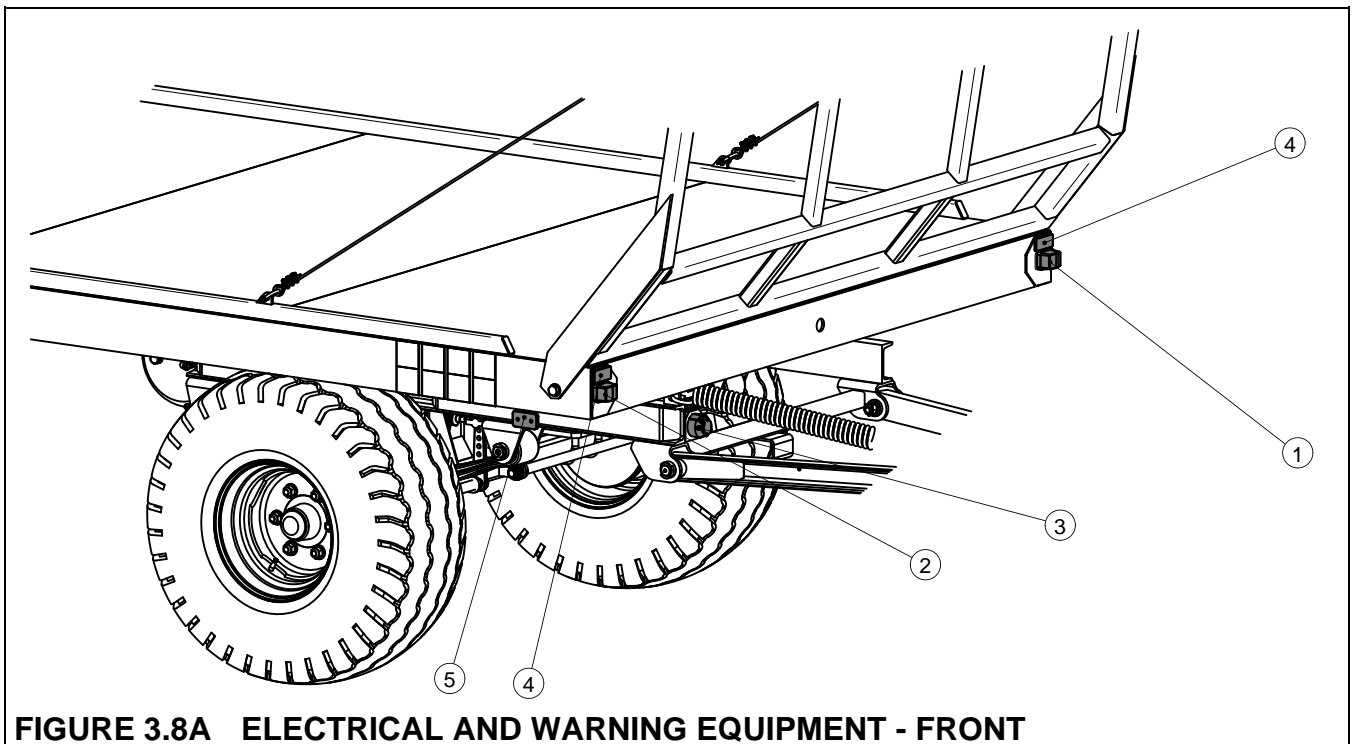

FIGURE 3.8A ELECTRICAL AND WARNING EQUIPMENT - FRONT

(1) front left parking light, (2) front right parking light, (3) front socket, (4) white reflector, (5) side clearance lamp (orange)

The trailer electrical system is designed for supply from direct current source of 12 V. Connection of the trailer electrical system with the tractor should be made through an appropriate connection lead delivered with the vehicle.

The trailer is also equipped with reflective lights that improve trailer visibility on the road.

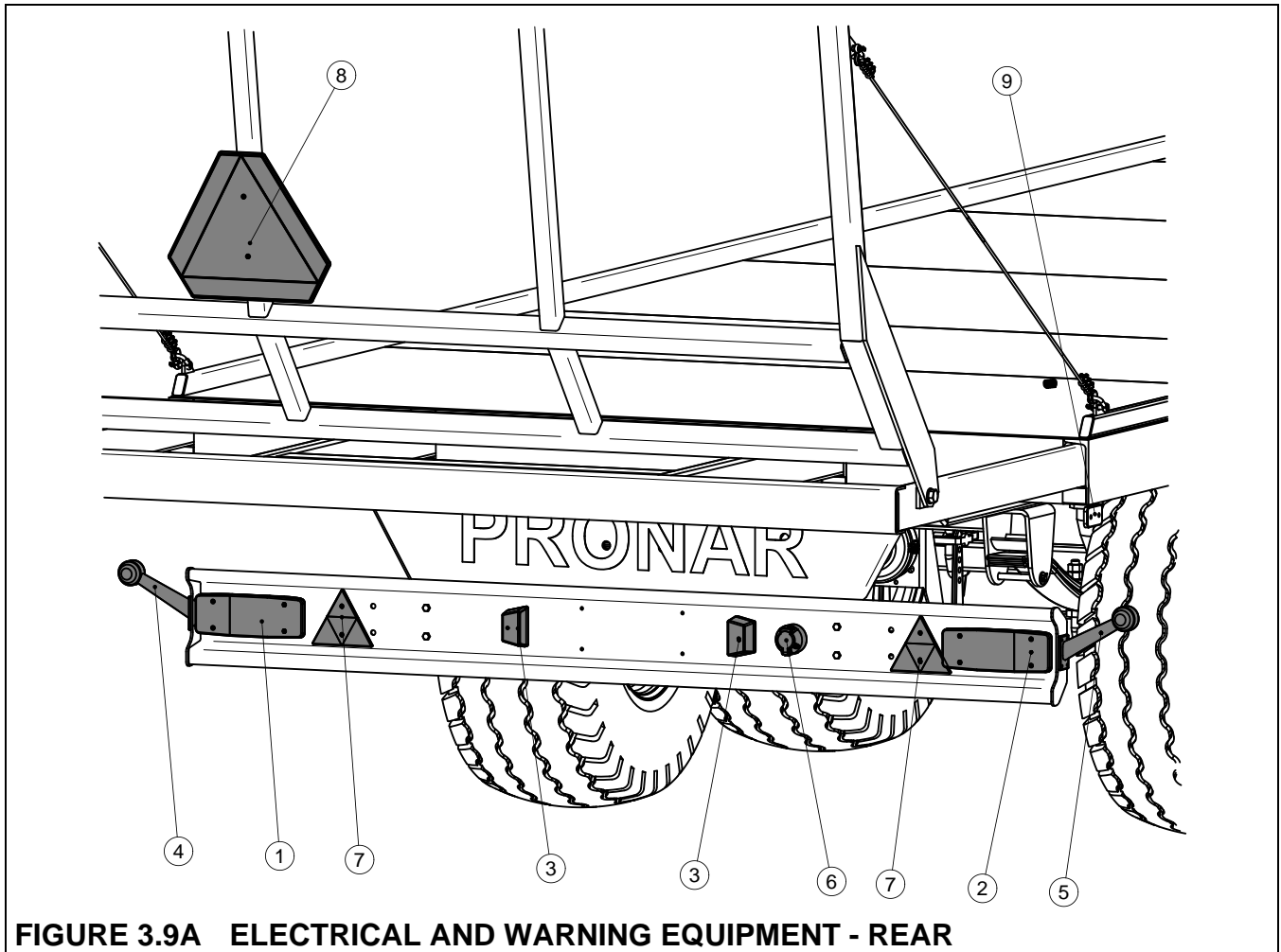

FIGURE 3.9A ELECTRICAL AND WARNING EQUIPMENT - REAR

(1) left rear lamp assembly, (2) right rear lamp assembly, (3) license plate light, (4) rear left clearance lamp, (5) rear right clearance lamp, (6) rear socket, (7) reflective triangle, (8) slow-moving vehicle triangle warning sign, (9) side clearance lamp (orange)

SECTION

4

CORRECT USE

PREPARING FOR WORK BEFORE FIRST USE

CHECK TECHNICAL CONDITION

HITCHING TO TRACTOR

LOADING, TRANSPORT AND UNLOADING

DISCONNECTING FROM TRACTOR

PROPER USE AND MAINTENANCE OF TYRES

4.1 PREPARING FOR WORK BEFORE FIRST USE

The trailer is supplied to the user completely assembled and does not require additional mounting operations of machine sub-assemblies. The manufacturer guarantees that the trailer is fully operational and has been checked according to quality control procedures and is ready for normal use. This does not release the user from an obligation to check the machine's condition prior to purchasing and before first use.

Before connecting to tractor, machine operator must check the technical condition of the trailer and adapt it to his/her own needs. In order to do this:

- the user must carefully read this operator's manual and observe all recommendations
- immobilise trailer with parking brake,
- check condition of paint coatings, traces of corrosion or mechanical damage (crushing, piercing, bending or breaking of minor elements),
- check air pressure in tyres and check correct tightening of wheel nuts,
- adapt the height of the trailer drawbar to the tractor hitch,

If all the above checks have been performed and there is no doubt as to the trailer's good technical condition, it should be hitched to tractor (see section 4.3). After connecting braking system conduits (hydraulic or pneumatic), the correct operation of individual systems should be checked by inspecting tightness of the system and cylinders.



ATTENTION!

Non-adherence to the recommendations contained in the Operator's Manual or improper use of the trailer may cause damage to the machine.

4.2 CHECK TECHNICAL CONDITION

Before commencing work check the following:

- technical condition of tyres and tyre pressure,
- tightening of nuts fixing the wheels, drawbar,
- condition of other bolt and nut connections,

- operation of lights and indicators.
- operation of brake system
- lubricate elements according to guidelines presented in section "Lubrication points", in compliance with maintenance schedule.

DANGER



The trailer must not be used when not in working order.

Careless and improper use and operation of the trailer, and non-compliance with the recommendations given in this operator's manual is dangerous to your health.

Non-compliance with the safety rules of this Operator's Manual can be dangerous to the health and life of the operator and others.

Pneumatic brake systems are equipped with connectors, whose safety caps, are made from coloured plastic. The colours of these elements correspond to the colours of the connection sockets in the tractor (yellow, red or black). Hydraulic brake supply conduit plug should be connected to the tractor hydraulic brake socket.

ATTENTION!



Prior to connecting individual system conduits the user must carefully read the tractor operator's manual and observe all Manufacturer's recommendations.

Before using the trailer, the user must carefully read this operator's manual.

The trailer must never be used by persons, who are not authorised to drive agricultural tractors, including children and people under the influence of alcohol or other drugs.

The trailer must not be used for purposes other than those for which it is intended.

Before using the trailer always check its technical condition. In particular, check the technical condition of the hitch system, the axle system, brake systems and indicator lights.

Proper functioning of main brakes can be confirmed only after connecting the trailer to the tractor. Do not use unreliable trailer until it is repaired. Adapt the height and position of the trailer drawbar to the tractor hitch before hitching trailer to tractor for the first time.

4.3 HITCHING TO TRACTOR

Prior to attempting to hitch the trailer to tractor, make sure that the tractor is immobilised with parking brake. The trailer may be attached only to the tractor equipped with upper transport hitch.



DANGER

When hitching, there must be nobody between the trailer and the tractor.

In order to attach the trailer to tractor, proceed as follows:

- immobilise the trailer with handbrake turning the brake mechanism crank (1) in direction (A),

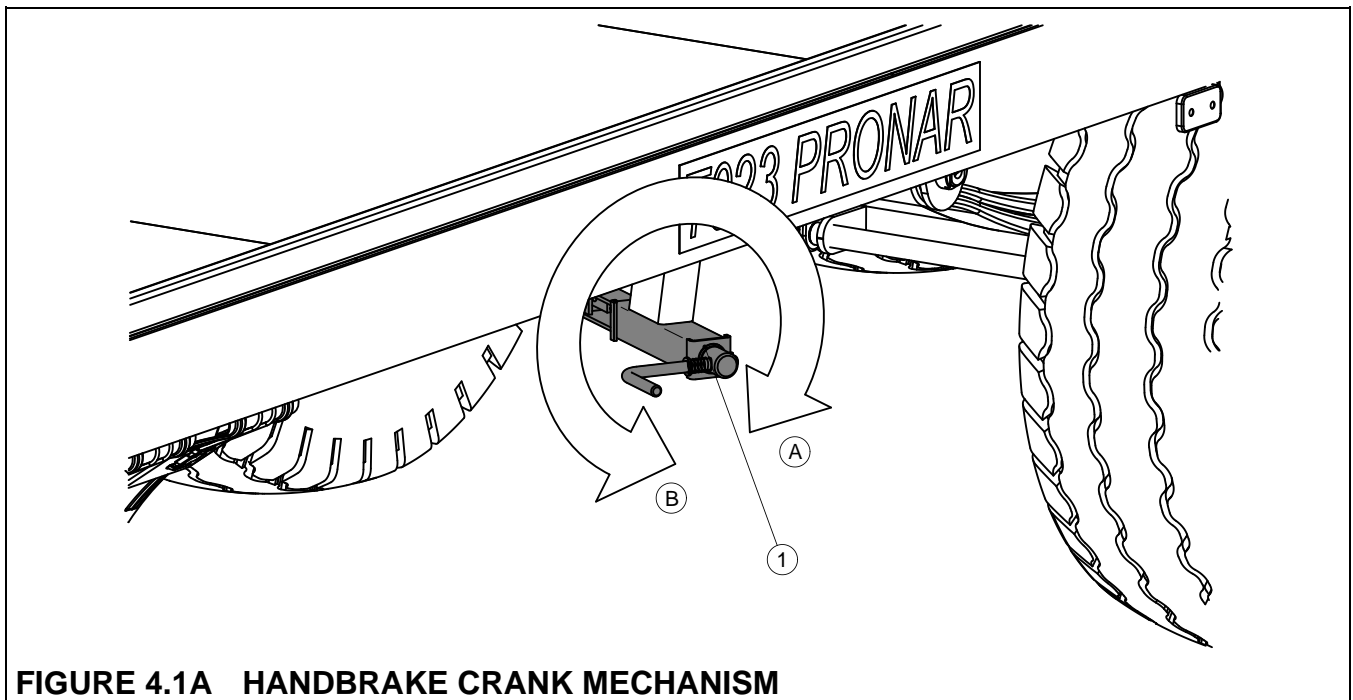

(1) crank mechanism, (A), (B) mechanism rotation direction

- position drawbar eye at the correct height (see section 5),
- while tractor is in reverse, connect drawbar eye to the tractor's upper hitch and check if the connection is secure,
- connect electrical leads and braking system conduits to the tractor,

- release parking handbrake, turning the crank of the parking brake's (1) mechanism in direction (B)
- mount slow moving vehicle warning triangle plate.

DANGER



Prior to attaching the trailer, check the technical condition of the trailer and tractor hitching system and connection elements of the electrical and braking systems.

Be especially careful when hitching the trailer to tractor.

When hitching, there must be nobody between the trailer and the tractor.

During hitching the trailer to the tractor only the upper transport hitch should be used. Check safety clips.

Rear frame should be retracted if the trailer is to move on public roads. In order to do this:

- immobilise trailer with parking brake
- unscrew bolt (2) that secures extendible frame (1) – compare figure (4.2A),
- shift frame (1) in direction (B) until resistance is felt ,
- relocate steel cable mount (3) to new position (seat (4)).

DANGER



Do NOT travel with machine, which has an unreliable brake, lighting or signalling system.

When turning, conduit connection tubes must hang loosely and not become tangled with moving elements of trailer and tractor.

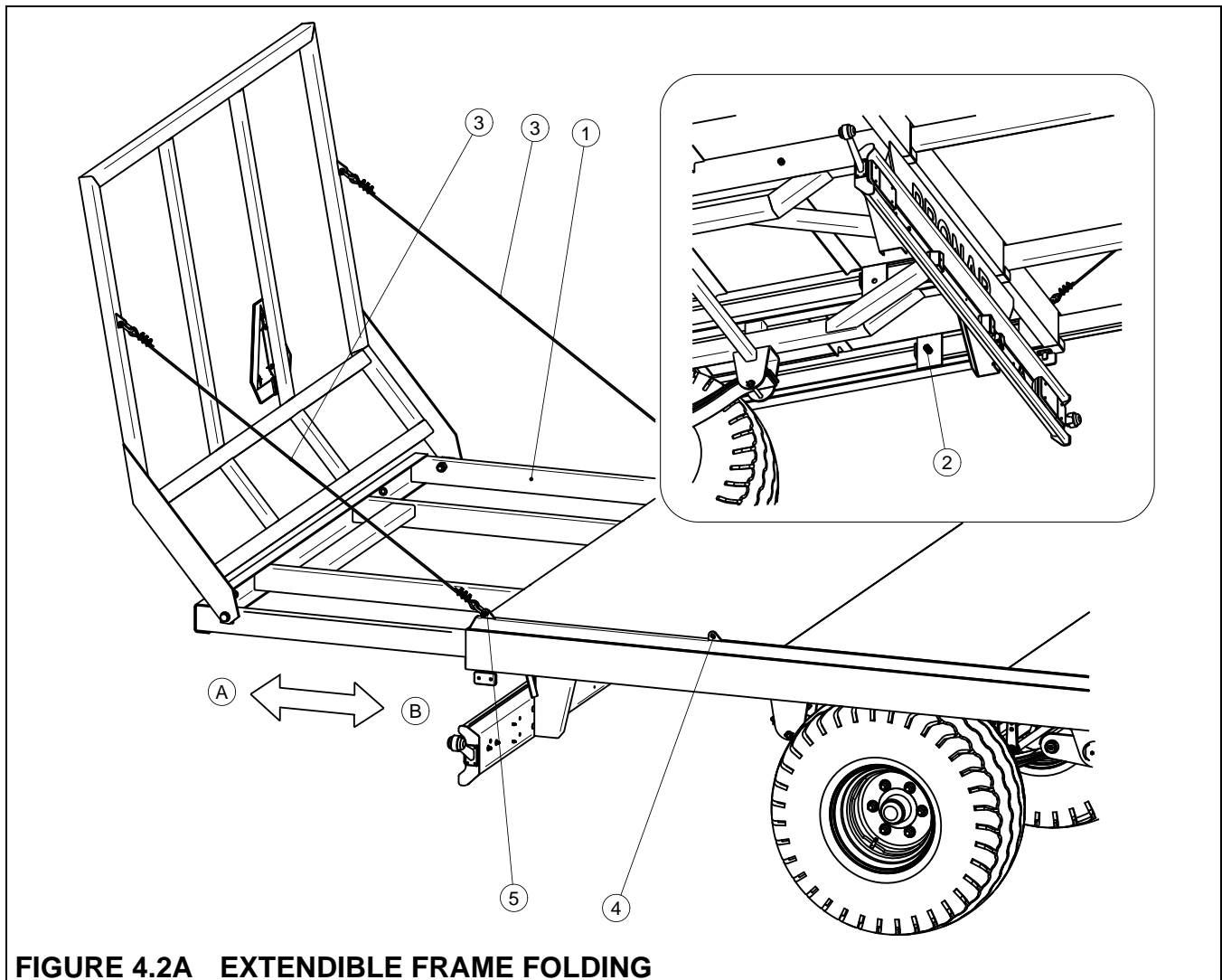

FIGURE 4.2A EXTENDIBLE FRAME FOLDING

(1) extendible frame, (2) locking bolt, (3) steel cable, (4), (5) steel cable mounting seats

4.4 LOADING, TRANSPORT AND UNLOADING

Load box can be loaded only when the trailer is connected to the tractor and positioned horizontally. Before loading, check the technical condition of linking cables and correctness of their attaching to the ladders and trailer frame. Do not load or drive the trailer with damaged linking cables.

Load should be uniformly distributed along the length and width of the platform in order to ensure proper distribution of axle loads and proper stability of the trailer. Load must not extend beyond the outline of the load platform. Number of load layers depends on size of pressed bales or blocks, their arrangement on the load platform and their weight. However, the permissible loading height defined by the road traffic regulations and permissible design load of the trailer must not be exceeded. When loading goods on pallets pay special attention

to load distribution on the platform. Pallets must be secured against the displacement on the platform. Pallets must not be stacked in layers.

Load (rectangular or round bales or pallets) should be adequately protected against moving by means of belts with a tightening mechanism. Belts may be attached to the left and right longitudinal member of the platform and to the front beam and rear beam of the extendible frame as well as to the fixing brackets welded to longitudinal members. The extent of protection depends on loading method, type of load and size of load. If load is to be transported on slopes and/or in strong gusty winds conditions, limit the load height according to existing conditions.

ATTENTION!



Do NOT exceed the trailer's maximum carrying capacity.

People or animals must not be carried.

Load placed on the platform must be uniformly distributed and properly secured.

Pay attention to danger posed by electric power lines.

While driving on public roads the extendible frame must be retracted.

Do not exceed the maximum speed when travelling. Travel speed should be adapted to the current road conditions.

Before unloading the trailer, position the trailer on flat surface, immobilise the tractor and trailer using parking brake. It is recommended to unload the trailer using a loader, conveyor or forklift truck. Keep a safe distance during loading and unloading. Do not allow anyone to approach the place where works are carried out.



DANGER

Ensure that during unloading nobody is in the vicinity of the load handled.

4.5 DISCONNECTING FROM TRACTOR

In order to disconnect the trailer from the tractor proceed as follows:

- stop the tractor, brake the tractor with parking brake.

- Immobilise trailer with parking brake.
- Disconnect from the tractor all electrical leads as well as braking system conduits, Protect terminals of the leads and conduits against soiling.
- disconnect the trailer drawbar hitching eye from the tractor hitch and move the tractor forward.



DANGER

The trailer unhitched from tractor must be immobilised with parking brake. If the machine is positioned on a slope or elevation it shall be additionally secured against moving by placing chocks or other objects without sharp edges under the trailer's wheels.

4.6 PROPER USE AND MAINTENANCE OF TYRES

- When working on the tyres, chocks or other objects without sharp edges should be placed under the wheels of the trailer to prevent it from rolling. Wheels can be taken off the trailer axle only when the trailer is not loaded.
- Repair work on the wheels or tyres should be carried out by persons trained and entitled to do so. This work should be carried out using appropriate tools.
- After removing a wheel, always check how firmly the nuts are screwed in. Individual checks should be made after the first use, after the first journey with a load, after travelling 1000 km and then every 6 months. The above actions should be repeated individually if a wheel has been removed from the wheel axle.
- Regularly check and maintain correct pressure in tyres according to Operator's Manual (especially if trailer is not used for a longer period).
- Pressure and tyres should be also checked after the whole day of intensive work. Please note that higher temperatures could raise tyre pressure by as much as 1 bar. At high temperatures and pressure, reduce load or speed.
- Do not release air from warm tyres to adjust the pressure or the tyres will be underinflated when temperatures return to normal.
- Protect tyre valves using suitable caps to avoid soiling.

- Do not exceed the trailer's maximum design speed.
- When trailer is operated all day, stop working for a minimum of one hour in the afternoon.
- Adhere to 30 minutes rest for cooling tyres after driving 75 km or after 150 minutes continuous travel depending on which occurs first.
- Avoid potholes, sudden manoeuvres or high speeds when turning.

SECTION

5

MAINTENANCE

CHECKING AND ADJUSTMENT OF WHEEL AXLE BEARINGS

ADJUSTMENT OF MAIN BRAKES

ADJUSTMENT OF MAIN BRAKES

PNEUMATIC SYSTEM OPERATION

HYDRAULIC SYSTEM OPERATION

LUBRICATION

ABSORBER SPRING SYSTEM MAINTENANCE

STORAGE

ADJUSTING DRAWBAR TO MATCH TRACTOR HITCH

TIGHTENING TORQUE FOR NUT AND BOLT CONNECTIONS

TROUBLESHOOTING

LIST OF BULBS

5.1 CHECKING AND ADJUSTMENT OF WHEEL AXLE BEARINGS

In newly purchased trailer, after covering a distance of 100 km, while during further use – after 6 months of vehicle use check and regulate wheel axle bearings when needed. Worn or damaged bearing should be replaced. Inspection of these elements should be conducted according to instructions below.

- Hitch trailer to tractor, place blocking chocks under trailer wheels and raise wheels in succession using the appropriate lifting jack. The lifting jack should be placed under the axle between U bolts fixing absorber springs to the axle. Make certain that the trailer will not move during inspection of the bearing.
- Turning the wheel slowly in both directions check that movement is smooth and that the wheel rotates without excessive resistance.
- Turn the wheel so that it rotates very quickly, check that the bearing does not make any unusual sounds.
- Grasp wheel above and below and try to feel any slack play, this may equally be checked with the aid of a jack placed under the wheel supported on the floor/ground.

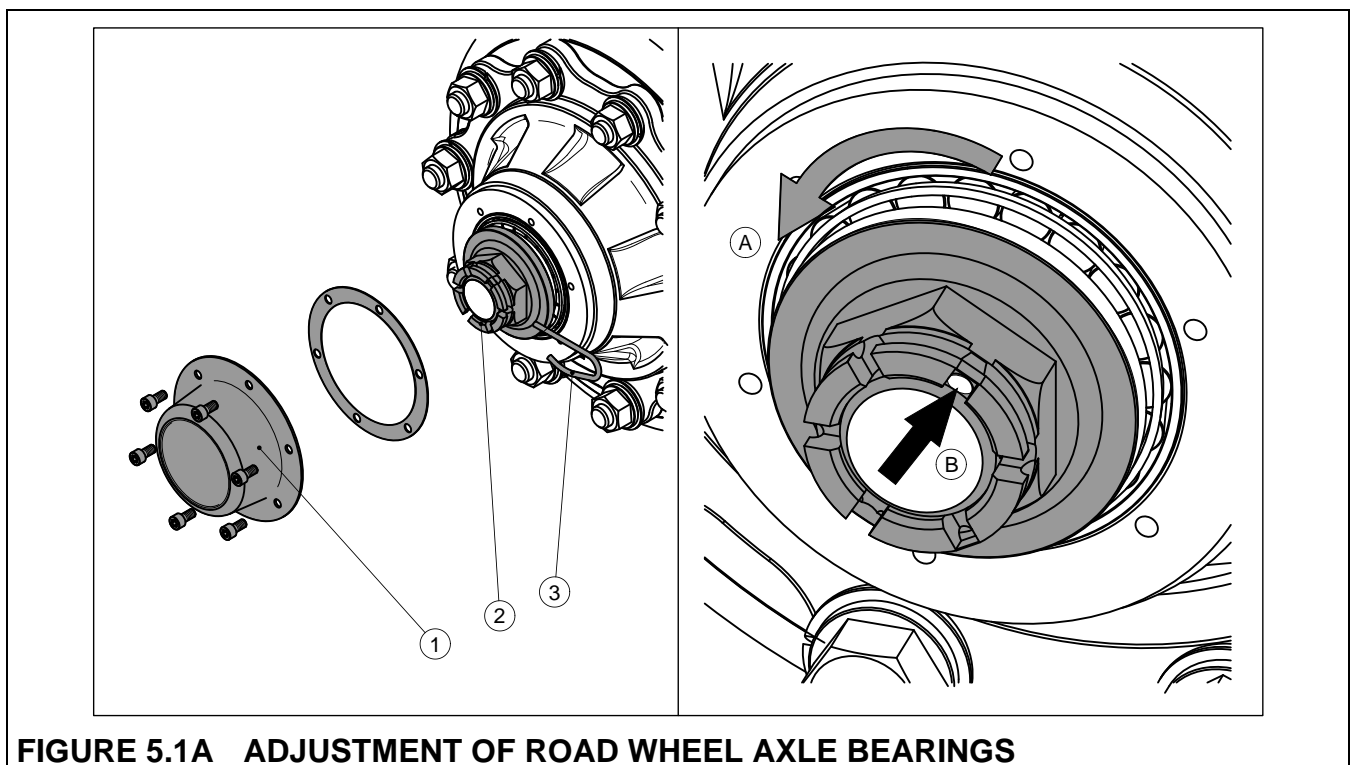

FIGURE 5.1A ADJUSTMENT OF ROAD WHEEL AXLE BEARINGS

(1) hub cover, (2) castellated nut, (3) securing split cotter pin

If slack is felt, adjust bearing. Unusual sounds coming from bearing may be symptoms of excess wear, dirt or damage. In such an event the bearing, together with sealing ring, should be replaced with new parts.

Bearing adjustment should be performed according to the following instructions – figure (5.1A):

- take off hub cover (1),
- take out split cotter pin (3) securing castellated nut (2),
- turning the wheel simultaneously tighten castellated nut until the wheel comes to a stop,
- unscrew nut in (A) direction, (not less than 1/3 rotation) to cover the nearest thread groove with alignment to opening in wheel stub axle (B).
- secure castellated nut with cotter pin and mount hub cap.

The wheel should turn smoothly without stiffness or detectable resistance not originating from abrasion of brake shoes in brake drum.

TABLE 5.1 HYDRAULIC LIFT REQUIREMENTS

LIFT CAPACITY	4,000 kg
HEIGHT OF LIFT RAM IN RETRACTED STATE	350 mm

Bearings replacement, lubrication and repairs connected with brake system and wheel axle should be entrusted to specialist service provider.



Inspection of slack and technical condition of wheel axle bearings must be performed after the first month of use, and then every 6 months of trailer use.

5.2 ADJUSTMENT OF MAIN BRAKES

Brakes adjustment is necessary when:

- as a result of wear of brake shoe linings between lining and drum there is excessive slack and reduced braking effectiveness,

- wheel brakes do not brake evenly or simultaneously.

If brakes are correctly adjusted, braking of wheels takes place simultaneously. Brakes adjustment involves changing setting of axle shaft expander arm (1) in relation to expander shaft (2). To do this, dismantle expansion washer and ring (3), dismantle axle shaft expander lever and set it in the correct direction i.e.:

- backwards - if brake brakes too late (A)
- forward - if brake brakes too early (B)

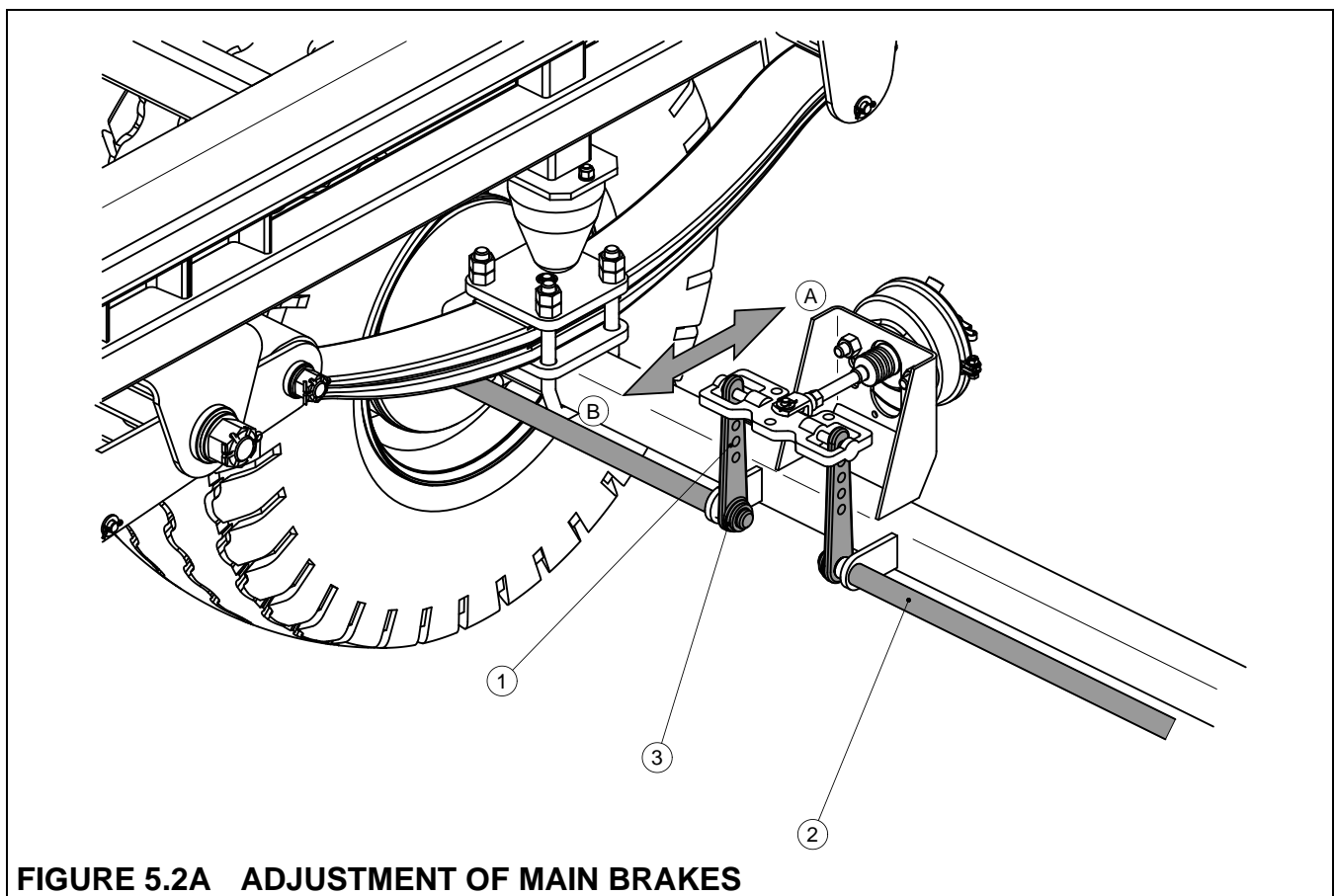

(1) expander arm, (2) expander shaft, (3) washer with a spring ring

Adjustment should be conducted separately for each wheel. After proper brake adjustment, at full braking the expanders' arms should create the angle of 90° with the pneumatic cylinder piston. With properly regulated brakes, trailer main brake braking force should reach a value not less than that given in table 5.2.

TABLE 5.2 MAIN BRAKE BRAKING FORCE

MAIN BRAKE BRAKING FORCE	UNIT
42	kN

Difference in braking force of left and right wheel may not be greater than 30%, considering that 100% constitutes greater force.



ATTENTION!

Braking force of the trailer, is the braking force of all trailer wheels.

Difference in braking force of all wheels may not be greater than 30%, considering that 100% constitutes greater force.



The main brake system should be inspected annually and in case of need should be regulated.

5.3 ADJUSTMENT OF MAIN BRAKES

Adjustment of parking brake should be conducted in the event of:

- stretching of cable,
- loosening of parking brake cable clamps
- after adjustment of main brake,
- after repairs in main brake system,
- after repairs in parking brake system.

Before commencing adjustment make certain that the main break is functioning properly. Length of parking brake cable should be so selected that at total release of working and parking brake the cable would be loose and hanging by 1 ÷ 2 cm. With properly adjusted brakes, the braking force of the trailer parking brake should reach a value not less than those given in table 5.3.

TABLE 5.3 PARKING BRAKE BRAKING FORCE

PARKING BRAKE BRAKING FORCE	UNIT
25	kN



ATTENTION!

Braking force of the trailer, is the braking force of all trailer wheels.



The parking brake system should be inspected annually and in case of need should be regulated.

5.4 PNEUMATIC SYSTEM OPERATION

As a part of trailer maintenance, conduct inspection of pneumatic system leaktightness, paying particular attention to all places of connection. Tightness of the system should be checked at nominal pressure in system of approximately 600 kPa (6.0 kg/cm²).

If conduits, seals or other system elements are damaged, compressed air will escape in these damaged places with a characteristic hiss, or for a minor leak, small air bubbles will show up. Small leaks can be detected by covering checked elements with washing fluid or other foaming preparations, which will not react aggressively with system elements. Damaged seals or conduits, causing leaks should be replaced. If the cause of the system leak is the outflow from a pneumatic cylinder, control valve body or braking force regulator, these components should not be repaired but replaced.

Condensation collecting as water should be removed from air tank periodically. In order to do this open out drain valve (1) located in the lower part of the tank. The compressed air in the tank causes the removal of water to the exterior. After release of the valve stem, the valve should automatically close and stop airflow from the tank. Annually before the winter period unscrew drain valve and clean off accumulated dirt. Replace copper seal.

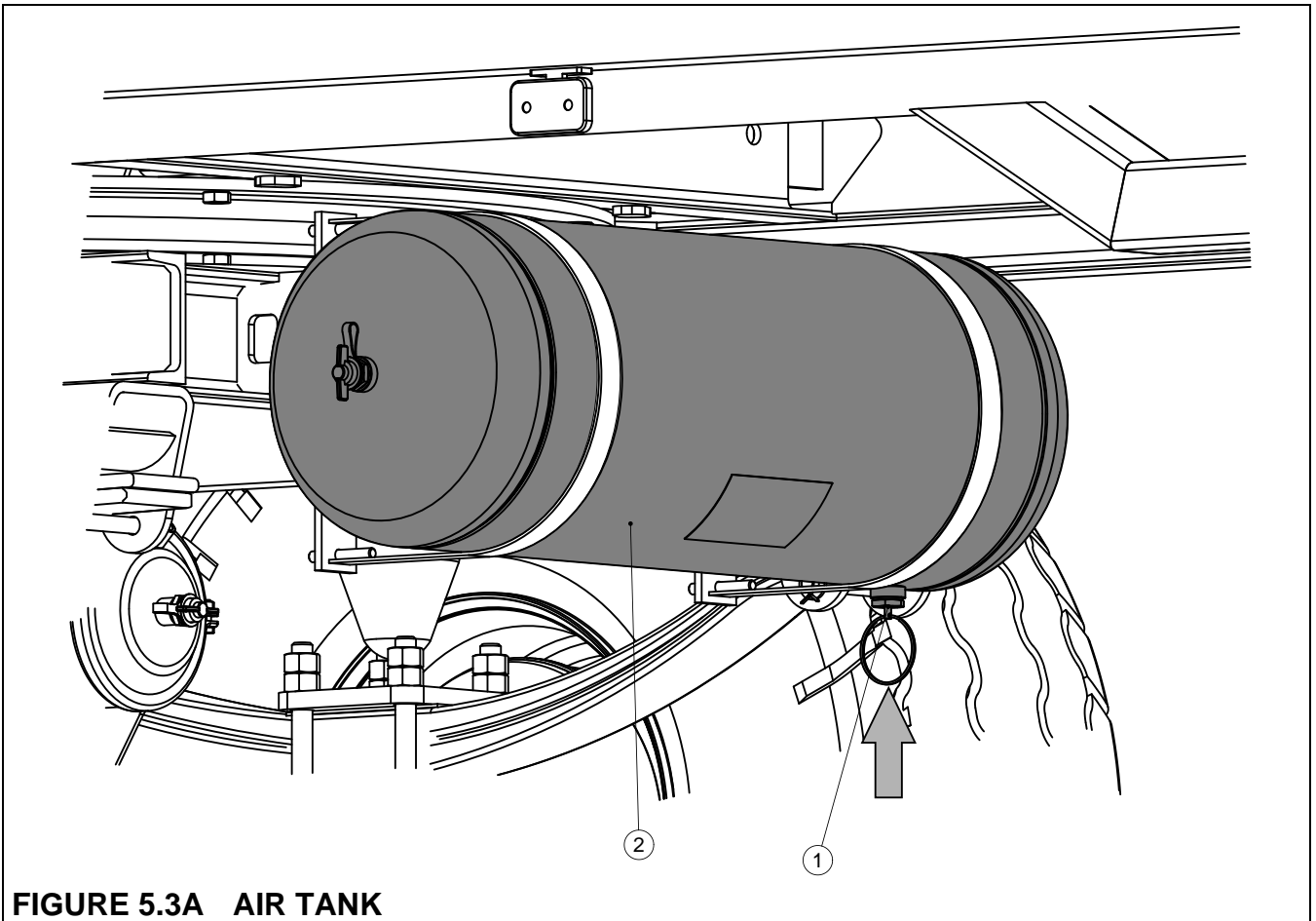

FIGURE 5.3A AIR TANK

(1) drain valve, (2) air tank,



Annually before the winter period unscrew and clean drain valve.

Inspection of tightness and inspection of pneumatic braking systems in detail should be conducted at least annually and after repairs associated with this system.

5.5 HYDRAULIC SYSTEM OPERATION

Always adhere to the principle that the oil in the trailer hydraulic system and in the tractor hydraulic system are of the same type. Application of different types of oil is not permitted. In a new trailer, the hydraulic system is filled with HL32 hydraulic oil.

The hydraulic system should be completely tight sealed. Checking tightness of the hydraulic system involves connecting the machine with the tractor and activating hydraulic brakes several times by pressing the brake pedal in the tractor operator cab. In the event of confirmation of an oil leak on hydraulic conduit connections, tighten connections, and if this does not remedy faults then change conduit or connection elements. If oil leak occurs beyond

connection, the leaking conduit system should be changed. Change of sub assemblies is equally required in each instance of mechanical damage. In the event of confirmation of damage to hydraulic motors, they must be replaced.

TABLE 5.4 HL32 HYDRAULIC OIL CHARACTERISTICS

ITEM	NAME	VALUE
1	ISO 3448VG viscosity classification	32
2	Kinematic viscosity at 40°C	28.8 – 35.2 mm ² /s
3	ISO 6743/99 quality classification	HL
4	DIN 51502 quality classification	HL
5	Viscosity index, min	95

ATTENTION!



Trailer with a leaking hydraulic system must NOT be used.
 The condition of hydraulic systems should be inspected regularly while using trailer.
 The hydraulic system is under high pressure when operating.
 Regularly check the technical condition of the connections and the hydraulic conduits.
 Use the hydraulic oil recommended by the Manufacturer. Never mix two types of oil.

In the event of intensive use of the hydraulic system, the hydraulic conduits should be replaced every 4 years.



Hydraulic conduits should be replaced after 4 years of trailer use.
 Detailed tightness and technical condition inspection of hydraulic system should be made at least annually.

In the event of necessity of changing hydraulic oil for another oil, check the recommendations of the oil Manufacturer very carefully. If it is recommended to flush the system with the appropriate preparation, then comply with these recommendations. Attention should be

given, so that chemical substances used for this purpose do not damage the materials of the hydraulic system.

5.6 LUBRICATION

Trailer lubrication shall be performed where indicated on figure (5.4A) as stipulated in table (5.5). After lubricating the machine according to instructions, wipe off excess grease or oil. Changing grease in wheel hub axle bearings should be entrusted to professional service.



During trailer use the user is obliged to observe lubrication instructions according to attached schedule. Excess oil or grease causes depositing additional contaminants in places requiring lubrication, therefore it is essential to keep individual machine elements clean.

TABLE 5.5 LUBRICATION POINTS

ITEM	NAME	NUMBER OF LUBRICATION POINTS	TYPE OF GREASE	LUBRICATION FREQUENCY
1	Handbrake crank mechanism	1	PERMANENT	3 – 4 months
2	Drawbar mounting pins	2	PERMANENT	3 – 4 months
3	Leaf spring absorber pins	6	PERMANENT	6 months
4	Rocker arm pins	2	PERMANENT	3 – 4 months
5	Leaf spring absorber sliding surfaces	6	PERMANENT	1 month
6	Leaf spring absorbers	6	GREASE SPRAY	3 – 4 months
7	Turntable	1	PERMANENT	3 – 4 months
8	Wheel bearings	6	PERMANENT	24 months

ITEM	NAME	NUMBER OF LUBRICATION POINTS	TYPE OF GREASE	LUBRICATION FREQUENCY
9	Resistance surfaces of front ladder and rear ladder	4	PERMANENT	3 – 4 months
10	Sliding surfaces of extendible frame	4	PERMANENT	3 – 4 months

IMPORTANT! Marking description in Item column in table (5.5) conforms with numbering shown in figure (5.4A).

5.7 ABSORBER SPRING SYSTEM MAINTENANCE

Maintenance of the absorber spring system involves periodical lubrication of the suspension in locations indicated in table (5.5) and monitoring of the technical condition of absorber plates on current basis.

The surface between the absorber plates should be protected using spray with anticorrosion and lubrication properties. Do not allow a thick layer of dry mud to accumulate on absorber plates.

5.8 STORAGE

It is recommended to keep the trailer in a closed or roofed building. Before longer outdoor storage of the machine, it is essential to protect the machine against adverse weather conditions, especially those causing corrosion and accelerated ageing of tyres. Tyres should be preserved at least once a year using generally available substances for this purpose.

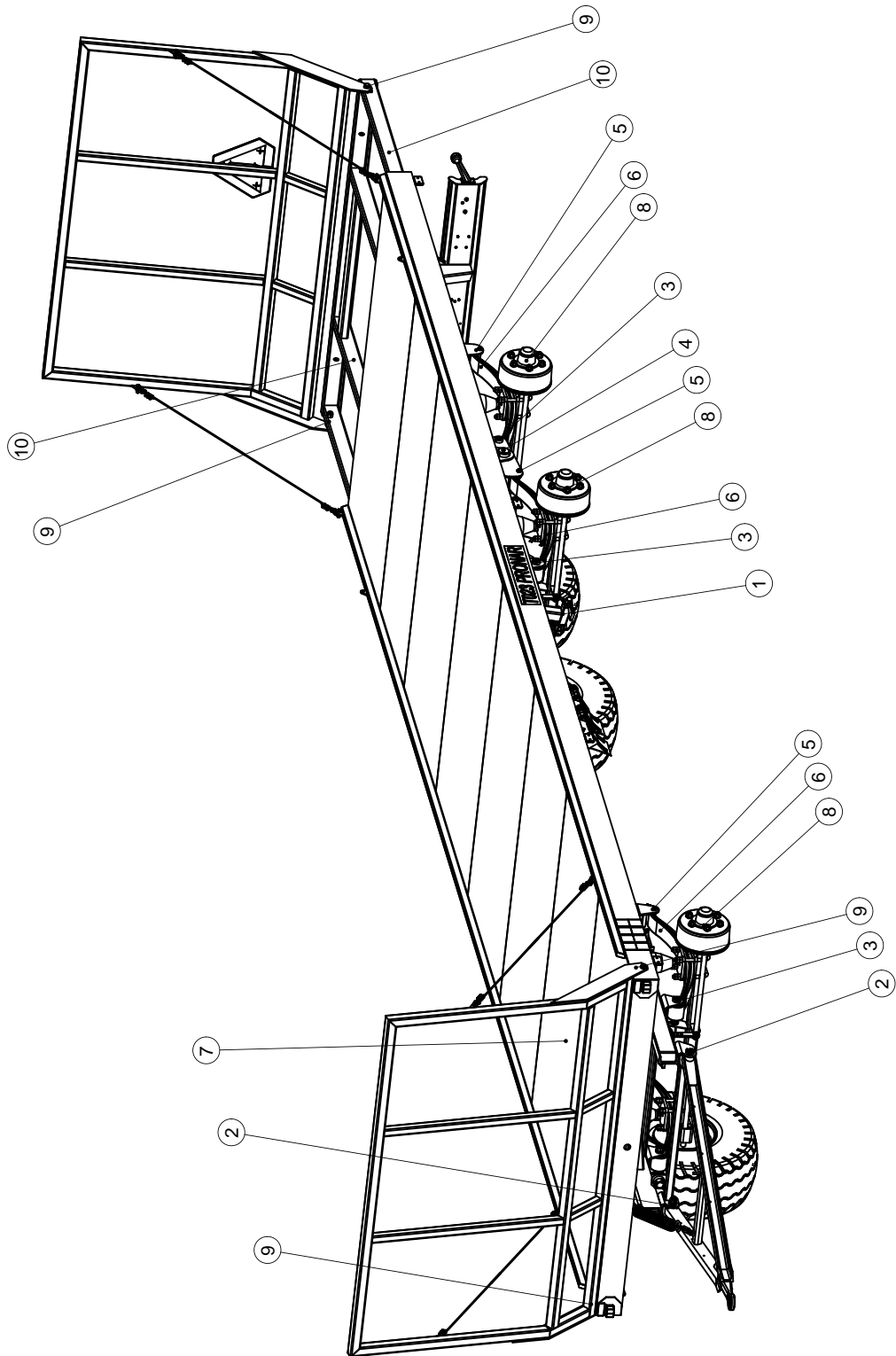

FIGURE 5.4A LUBRICATION POINTS

Marking description conforms with table (5.5)

5.9 ADJUSTING DRAWBAR TO MATCH TRACTOR HITCH

Drawbar position depends on the height of the tractor hitch. In order to make correct adjustment:

- hold drawbar hitching eye,
- loosen nut (2) that fixes clamping ring (1) to drawbar
- lift the drawbar until the spring is loose
- move the clamping ring in direction (A), if the drawbar hitching eye is located too low
- move the clamping ring in direction (B), if the drawbar hitching eye is located too high in relation to the hitch
- tighten the nut and lower the drawbar

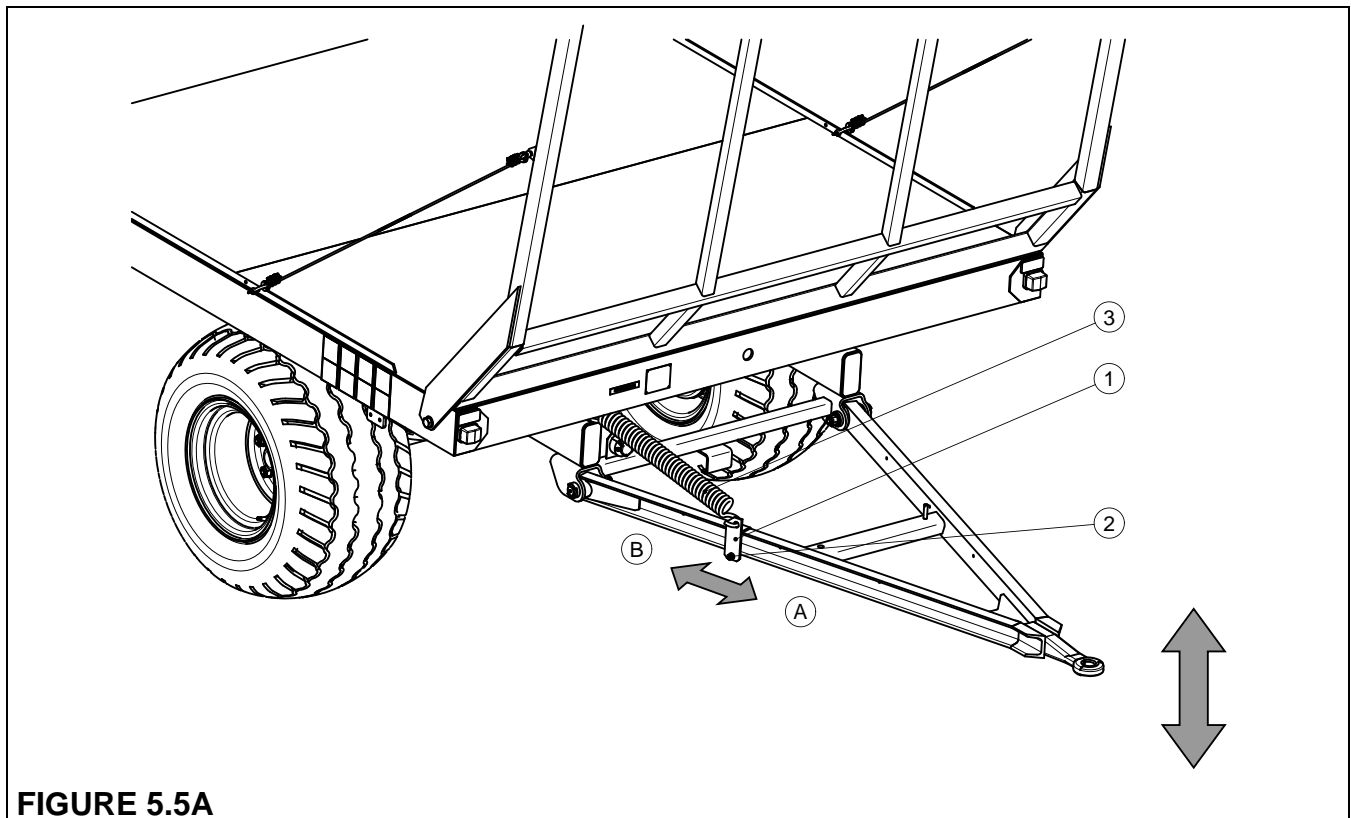

FIGURE 5.5A

(1) clamping ring, (2) bolt connection, (3) spring

5.10 TIGHTENING TORQUE FOR NUT AND BOLT CONNECTIONS

Unless other tightening parameters are given, during maintenance repair work apply appropriate torque to tightening nut and bolt connections. Recommended tightening torque of

most frequently applied nut and bolt connections are given in table below. Given values apply to non-lubricated steel bolts.

TABLE 5.6 TIGHTENING TORQUE FOR NUT AND BOLT CONNECTIONS

THREAD (d) [mm]	5.8	8.8	10.9
	M_D [Nm]		
M6	8	10	15
M8	18	25	36
M10	37	49	72
M12	64	85	125
M14	100	135	200
M16	160	210	310
M20	300	425	610
M24	530	730	1,050
M27	820	1,150	1,650
M30	1,050	1,450	2,100

(M_D) – tightening torque, (d) thread diameter

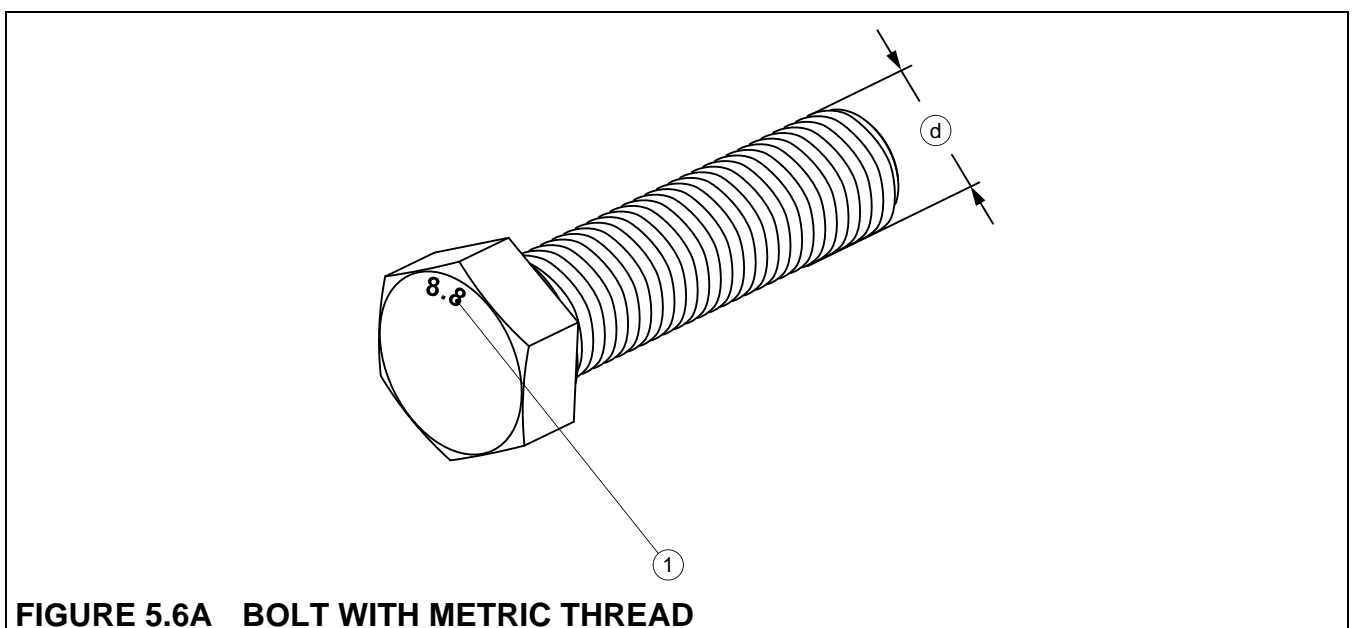

FIGURE 5.6A BOLT WITH METRIC THREAD

(1) bolt strength class, (d) thread diameter

5.11 TROUBLESHOOTING

TABLE 5.7 FAULTS AND MEANS OF REMEDYING THEM

FAULT	CAUSE	REMEDY
Problem with moving off	Pneumatic brake system conduit(s) not connected	Connect brake conduit.
	Damaged pneumatic system connection conduits	Replace
	Leaking connections	Tighten, replace washers or seal set
	Parking brake applied	Release parking brake
Noise in axle hubs	Excessive slack in bearings	Check slack and regulate if needed
	Damaged bearing	Change bearing together with sealing ring
Excessive heating of axle hubs	Incorrectly regulated main brake	Regulate setting of expander arms
	Incorrectly regulated parking brake	Adjust tension of parking brake cables
	Worn brake linings	Change brake shoes

5.12 LIST OF BULBS

TABLE 5.8 LIST OF BULBS

LAMP	BULB
Front parking lamp left/right LO - 110PP	C5W-SV8.5
Left/right clearance lamp	R5W
License plate light LT - 120	C5W-SV8.5
Rear lamp assembly: left WE 549L, right WE 549P	indicator light: P21W brake light: P21W parking light: R10W



ATTENTION!

The trailer's electrical system is supplied with 12V.

NOTES

A series of horizontal dotted lines for writing notes.



