



PRONAR Sp. z o.o.

17-210 NAREW, UL. MICKIEWICZA 101A, PODLASKIE PROVINCE

tel.:	+48 085 681 63 29	+48 085 681 64 29
	+48 085 681 63 81	+48 085 681 63 82
fax:	+48 085 681 63 83	+48 085 682 71 10

www.pronar.pl

OPERATOR'S MANUAL

DISC MOWER

PRONAR PDT250

TRANSLATION OF THE ORIGINAL INSTRUCTIONS

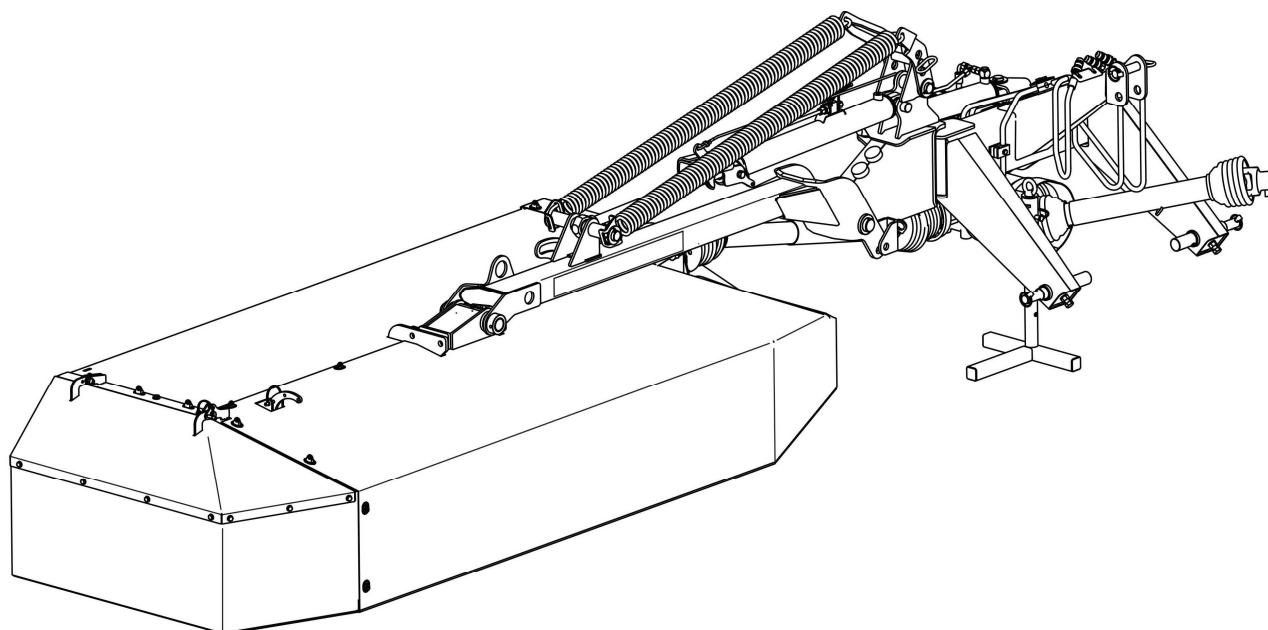

ISSUE 2B-01-2010

PUBLICATION NO 184N-0000000-UM



DISC MOWER

PRONAR PDT250

MACHINE IDENTIFICATION

SYMBOL /TYPE: PDT250

SERIAL NUMBER:

--	--	--	--	--	--

INTRODUCTION

Information contained herein is current at date of publication. As a result of improvements, some numerical values and illustrations contained in this publication may not correspond to the factual specification of the machine supplied to the user. The manufacturer reserves the right to introduce design changes in machines produced that facilitate operation and improve the quality of their work, without making minor amendments to this Operator's Manual. Please send your comments and proposals on the design and operation of the machine to the manufacturer. This information enables objective evaluation of the machines produced and provides indications for their further improvement.

This Operator's Manual is an integral part of the machine's documentation. Before using the machine, the user must carefully read this Operator's Manual and observe all recommendations. This guarantees safe operation and ensures malfunction free work of the machine. The machine is designed to meet obligatory standards, documents and legal regulations currently in force.

The manual describes the basic safety rules and operation of the implement. If the information contained in the Operator's Manual needs clarification then the user should refer for assistance to the sale point where the machine was purchased or to the manufacturer.

Manufacturer's address:

PRONAR Sp. z o.o.

ul. Mickiewicza 101A

17-210 Narew

Contact telephones

+48 085 681 63 29

+48 085 681 64 29

+48 085 681 63 81

+48 085 681 63 82

Information, descriptions of danger and precautions and also recommendations and orders associated with user safety instructions are marked:



and also preceded by the word "**DANGER**". Failure to observe the instructions may endanger the machine operator's or other person's health or life.

Particularly important information and instructions, the observance of which is essential, are distinguished in the text by the sign:



and also preceded either word "**ATTENTION**". Failure to observe the instructions may lead to damage to the machine as a result of improper operation, adjustment or use.

In order to focus the user's attention on the need to perform maintenance, the relevant section of the Operator's Manual is marked with the pictogram:



TABLE OF CONTENTS

- 1. BASIC INFORMATION 1.1**
 - 1.1 IDENTIFICATION DATA..... 1.2
 - 1.2 PROPER USE 1.3
 - 1.3 OPTIONAL EQUIPMENT 1.4
 - 1.4 WARRANTY TERMS..... 1.5
 - 1.5 TRANSPORT..... 1.6
 - 1.6 ENVIRONMENTAL HAZARDS 1.7
 - 1.7 WITHDRAWAL FROM USE 1.8

- 2. SAFETY IN USE 2.1**
 - 2.1 BASIC SAFETY RULES 2.2
 - 2.2 DRIVING ON PUBLIC ROADS 2.6
 - 2.3 DESCRIPTION OF MINIMAL RISK 2.6
 - 2.4 INFORMATION AND WARNING DECALS..... 2.7

- 3. DESIGN AND OPERATION 3.1**
 - 3.1 TECHNICAL SPECIFICATION..... 3.2
 - 3.2 GENERAL DESIGN 3.3
 - 3.3 LINKAGE 3.4
 - 3.4 HYDRAULIC SYSTEM 3.5
 - 3.5 DRIVE TRANSMISSION..... 3.6
 - 3.6 CUTTING UNIT..... 3.7

- 4. CORRECT USE 4.1**
 - 4.1 PREPARING FOR WORK 4.2
 - 4.2 CHECKING TECHNICAL CONDITION..... 4.4
 - 4.3 ATTACHING TO TRACTOR..... 4.5
 - 4.4 TRANSPORTING THE MACHINE 4.8
 - 4.5 SETTING AND MOWING 4.12
 - 4.6 DISCONNECTING FROM TRACTOR..... 4.19

- 5. MAINTENANCE 5.1**
 - 5.1 CHECKING AND REPLACING CUTTING KNIVES..... 5.2
 - 5.2 CUTTERBAR MAINTENANCE 5.5
 - 5.3 DRIVE SYSTEM MAINTENANCE 5.7

5.4 HYDRAULIC SYSTEM OPERATION.....5.9
5.5 STORAGE.....5.11
5.6 LUBRICATION5.12
5.7 TIGHTENING TORQUE FOR NUT AND BOLT CONNECTIONS.....5.15
5.8 FAULTS AND MEANS OF REMEDYING THEM.....5.16

SECTION

1

BASIC INFORMATION

IDENTIFICATION DATA

PROPER USE

EQUIPMENT

WARRANTY TERMS

TRANSPORT

ENVIRONMENTAL HAZARDS

WITHDRAWAL FROM USE

1.1 IDENTIFICATION DATA

PRONAR Sp. z o.o. 17-210 Narew ul. Mickiewicza 101A		CE	
Nazwa	A		
Typ	B	Nr seryjny	C
Rok prod.	D	KJ	F
Masa	E	kg	
G			

FIG. 1.1A Data plate

The meaning of the individual fields found on the data plate (FIG. 1.1A):

- | | |
|-----------------------------|-----------------------------|
| A – Machine name | B – Type |
| C – Serial number | D – Production year |
| E – Total weight | F – Sign of quality control |
| G – Machine name, continued | |

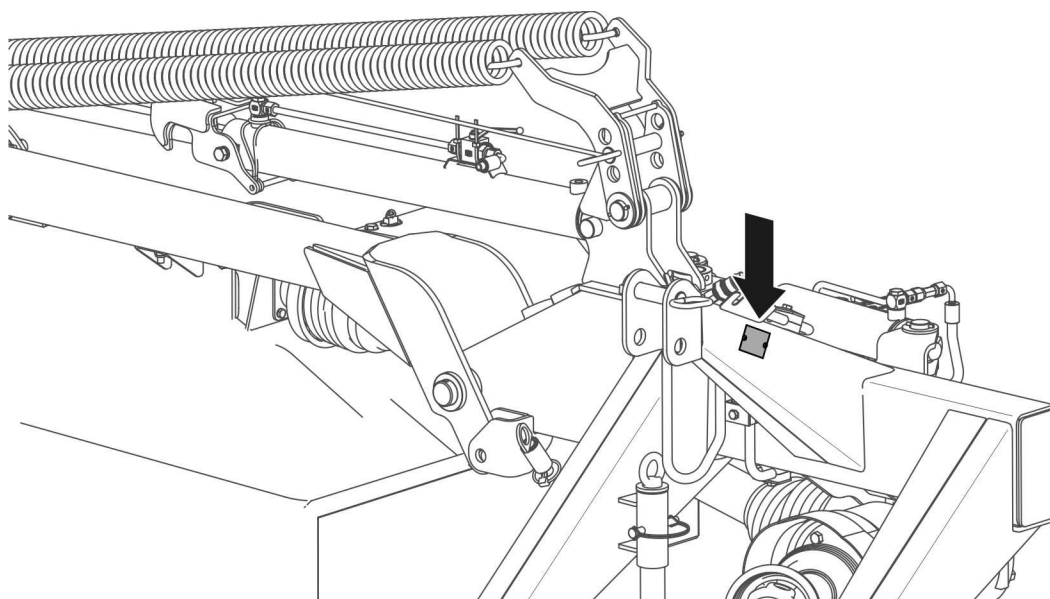

FIG. 1.2 A Location of the data plate

A data plate is affixed on the mower. It is located on the left side, on the upper beam of the linkage frame (FIGURE 1.2A). When buying the mower check that the serial number on the machine corresponds to the number written in the *WARRANTY BOOK*, in the sales documents and in the *OPERATOR'S MANUAL*. The meaning of the individual fields found on the data plate are presented in FIG. 1.1A

1.2 PROPER USE

The PDT250 rear mounted disc mower is designed to cut grass and low stemmed green fodder (lucerne, etc) on permanent grassland and on stone free cultivated fields with a level surface.

Use of the machine for other purposes is not in accord with its design. Using it as intended also involves all actions connected with the safe and proper operation and maintenance of the machine. Due to the above, the user is obliged to:

- carefully read the *Operator's Manual* and comply with its recommendations,
- understand the operating principle of the machine's operation and of its safe and proper use,
- comply with general safety regulations while working,
- prevent accidents,
- comply with road traffic regulations.



IMPORTANT!

The mower must not be used for purposes other than those for which it is intended.

Unauthorised repairs and modifications of the machine without prior consent of the Manufacturer will be regarded as use contrary to the intended purpose. The machine may only be used by appropriately trained users, who are aware of the dangers, design and operation of the machine. Repairs to the machine shall only be made by qualified personnel (in the guarantee period all repairs must be performed in the guarantee service, indicated by the Manufacturer). Maintenance and repairs that can be performed by the user, are described in section 5 „*Technical Maintenance*”.

TAB. 1.1 THE AGRICULTURAL TRACTOR'S REQUIREMENTS

	MEASURED AS	REQUIREMENTS
Linkage Rear three point linkage	-	Category II and III according to ISO 730
Power take-off shaft PTO speed	RPM	540
Number of splines on PTO shaft	pcs	6
PTO rotation direction	-	clockwise
Hydraulic system Nominal pressure	MPa	16
Hydraulic oil	-	HL32
Hydraulic sockets	-	3 sockets on rear of tractor
Other requirements Minimum power	kW/KM	30 / 40

1.3 EQUIPMENT

TAB. 1.2 PDT250 MOWER OPTIONAL EQUIPMENT

EQUIPMENT	QUANTITY
Operator's Manual	1
Warranty book	1
PTO shaft connecting tractor and mower	1

Recommended PTO shafts:

- PTO shaft connecting tractor and mower – T401010ENC12RF2
- PTO shaft connecting intersecting axis gears of the mower – T400610N112112

1.4 WARRANTY TERMS

The manufacturer guarantees the reliable operation of the machine when it is used according to its intended purpose as described in the Operator's Manual. Faults discovered during the warranty period will be repaired by the Warranty Service. Repair deadline is given in warranty booklet.

The guarantee does not apply to those parts and sub-assemblies of the machine, which are subject to wear in normal usage conditions, regardless of the warranty period. The warranty service only applies to such cases as: mechanical damage which is not the user's fault, factory defects of parts, etc. Consumables include the following parts/sub-assemblies:

- cutting knives,
- protective aprons,
- bearings.

In the event of damage arising from:

- mechanical damage which is the user's fault, caused by road accidents,
- by inappropriate use, adjustment or maintenance, use of the machine for purposes other than those for which it is intended,
- use of damaged machine,
- repairs carried out by unauthorised persons, improperly carried out repairs,
- arbitrary and wilful adjustments to the machine's structure,

the user may lose the right to warranty service.

The user is obliged to report immediately on noticing any wear in the paint coating or traces of corrosion, and to have the faults rectified whether they are covered by the guarantee or not. Detailed guarantee regulations are contained in the Warranty Book attached to each machine.



ATTENTION!

Demand that the seller carefully and precisely fills out the *WARRANTY BOOK* and guarantee repair coupons. A missing date of purchase or sale point stamp, may make the user ineligible for any warranty repair or refund.

1.5 TRANSPORT

The machine is prepared for sale completely assembled and does not require packing. Packing is only required for the machine operator's manual and elastic covers. Supply to user takes place by transport vehicle. Transport of the mower is permissible connected to a tractor provided the tractor's driver familiarises himself with the machine's Operator's Manual and particularly with information concerning safety and principles of connection and transport of mower on public roads. Do NOT drive the tractor with mower connected when visibility is limited.

DANGER



When transporting independently, the user must carefully read this operator's manual and observe its recommendations. When being transported on a motor vehicle the machine must be mounted on the vehicle's platform in accordance with the transport safety requirements. The driver of the vehicle should take particular care while transporting the machine. This is due to the vehicle's centre of gravity shifting upwards when loaded with the machine.

When loading and unloading the machine, comply with the general principles of workplace health and safety for reloading work. Persons operating reloading equipment must have the qualifications required to operate these machines.

The machine should be attached to lifting equipment in places intended for this (FIG. 1.3A), i.e. two central connection pin (1) and transport lug (2). When lifting the machine take particular care due to the possibility of tipping over the machine and the risk of injuries from protruding parts. To keep lifted machine in the correct direction it is recommended to apply additional guy ropes. During the loading work particular care should be taken not to damage paint coating.

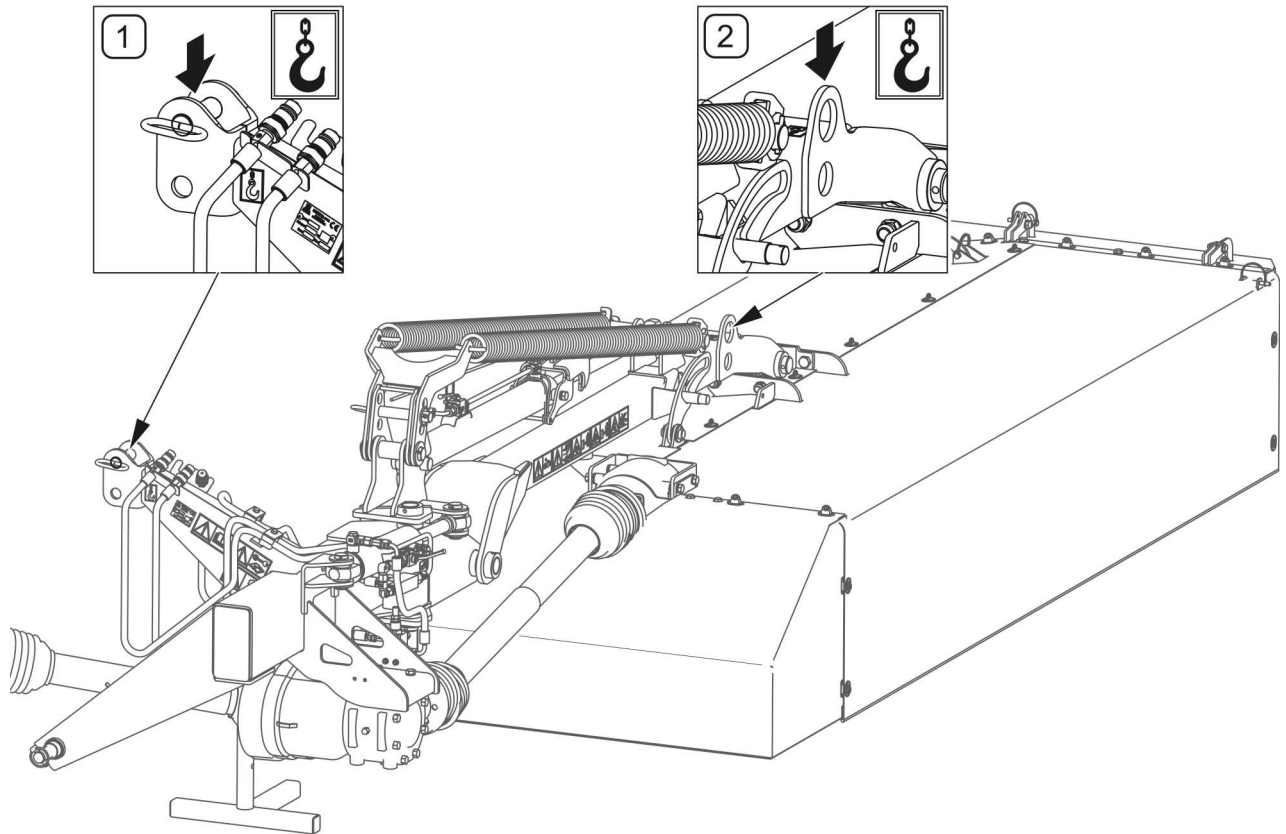

FIG. 1.3A Transport lugs

(1)- central connection pin; (2)- lifting arm lug



DANGER

During loading mower should be set in working position and secured. Support leg should be lowered and secured with a pin.



ATTENTION!

Do not secure brackets or any types of securing elements to hydraulic cylinders.

1.6 ENVIRONMENTAL HAZARDS

A hydraulic oil leak constitutes a direct threat to the natural environment owing to its limited biodegradability. While carrying out maintenance and repair work which involves the risk of an oil leak, this work should take place on an oil resistant floor or surface. In the event of oil leaking into the environment, first of all contain the source of the leak, and then collect the leaked oil using available means. Remaining oil should be collected using sorbents, or

by mixing the oil with sand, sawdust or other absorbent materials. Collected oil should be kept in sealed and clearly marked containers away from heat sources, flammable materials and food. Oil waste should be taken to the appropriate facility dealing with the re-use of this type of waste.

It is recommended to store used oil in its original packaging.

1.7 WITHDRAWAL FROM USE

Before proceeding to dismantle the machine, oil shall be completely removed from hydraulic system, cutterbar, and both intersecting axis gears. Locations of drain plugs and method for draining oil are described in section 5.



DANGER

During dismantling personal protection equipment shall be used i.e. protective clothing, boots, gloves and glasses etc.

Avoid contact of skin with oil. Do not allow used oil to spill.

Worn metal parts remaining after repairs and unsuited for regeneration shall be scrapped. Waste oil and also rubber and plastic elements should be taken to establishments undertaking the utilisation of such materials.

SECTION

2

SAFETY ADVICE

BASIC SAFETY RULES

DRIVING ON PUBLIC ROADS

DESCRIPTION OF MINIMAL RISK

INFORMATION AND WARNING DECALS

2.1 BASIC SAFETY RULES

- Before using the machine the user should carefully read this Operator's Manual and the PTO shaft Operator's Manual and adhere to the recommendations contained in these documents.
- The machine may only be used and operated by persons qualified to drive and trained in the use of agricultural tractors.
- If the information contained in the Operator's Manual is difficult to understand, contact a seller who runs an authorised technical service on behalf of the manufacturer, or contact the manufacturer directly.
- Be aware of existence of a minimal risk, and for this reason the fundamental basis for using this machine should be the application of safety rules and sensible behaviour.
- The machine must never be used by persons who are not authorised to drive agricultural tractors, including children and people under the influence of alcohol or other drugs.
- Non-compliance with the safety rules of this Operator's Manual can be dangerous to the health and life of the operator and others.
- The machine must not be used for purposes other than those for which it is intended. Anyone who uses the machine other than the way intended takes full responsibility for himself for any consequences of this use.
- Any modification to the machine frees the manufacturer from any responsibility for damage or detriment to health which may arise as a result.
- Before using the machine always check its technical condition. In particular check the technical condition of the hitch, PTO drive, cutting system and correct mounting of protective guards.
- Do NOT ride on the machine or transport any materials on it.
- The machine may only be used when all the safety guards and other protective elements are technically sound and correctly positioned. In the event of loss or destruction of the safety guards, they must be replaced with new ones.

- Before hitching the machine to the tractor, check the technical condition of the hitching system of the mower and the tractor.
- Be especially careful when attaching the machine to the tractor..
- When reversing the tractor, there must be nobody between the mower and the tractor.
- To attach the machine to the tractor only the rear Three-Point Linkage System may be used. After mounting the machine, check the safeguards.
- To mount machine on tractor use only genuine pins and safeguard linchpins.
- When connecting the hydraulic conduits, make sure that the hydraulic system is not under pressure.
- The machine may only be connected to the tractor by appropriately selected PTO shaft recommended by the Manufacturer.
- The PTO shaft has markings on the casing, indicating which end of the shaft shall be connected to the tractor.
- The chains preventing the shaft cover from turning while the shaft is working, shall be secured to a fixed element of machine structure.
- Do NOT use the securing chains to support the shaft while machine is parked or being transported.
- The driveshaft must be equipped with a cover. Do NOT use the shaft with damaged or missing guards.
- After connecting shaft ensure that it is correctly and safely connected to the tractor and to the mower.
- Before starting PTO shaft make certain that the PTO rotation direction is correct.
- Before using the machine the user should thoroughly acquaint himself with the PTO shaft Operator's Manual and adhere to the recommendations contained in it.
- Disconnect the drive shaft each time when it is not necessary to drive the machine.
- Do NOT go over and under the shaft or stand on it equally during work as also when the machine is parked.

- Do NOT wear loose clothing, straps or whatever may become wrapped round the rotating drive shaft. Contact with rotating PTO shaft may cause severe injuries.
- The mower may not be used or transported in conditions of limited visibility.
- When transporting the mower mounted on the tractor, close all hydraulic cylinders valves.
- Do NOT ride on the machine or transport any materials on it.
- Before lowering or lifting the mower mounted on the three-point linkage, make sure there are no bystanders, especially children, near the machine.
- Before starting the mower make sure that there are no bystanders (especially children) or animals in the danger zone (an area with a radius of up to 50 m from the mower). The machine operator is obliged to ensure proper visibility of the machine and the working area.
- Before starting the mower's PTO shaft, the cutting unit must be in working position.
- Mowing should begin after reaching nominal PTO RPM of 540 rpm. Do NOT overload shaft and mower and also engage the clutch suddenly.
- During cutting do NOT use PTO revolution speed greater than 540 rpm.
- When mowing on the edges of streets, public roads, on stony ground there is a risk that thrown out stones and foreign bodies may pose a risk to bystanders and other vehicle passing by.
- Do NOT leave the tractor cab, when the machine drive is engaged.
- Do NOT stand within the machine's working zone.
- Do NOT approach cutting unit guards until the rotating cutting parts come to a complete standstill.
- Do NOT operate mower while reversing. While reversing lift machine.
- The mower's hydraulic system is under high pressure when operating.
- Before disconnecting the shaft, turn off the tractor engine and remove the key from the ignition.
- Reduce pressure prior to disconnecting the hydraulic system.
- Before disconnecting mower from the tractor's linkage, lock the lifting arm in parking position.

- Mower disconnected from tractor must be supported on a support leg.
- When operating the machine wear protective gloves and use the appropriate tools.
- Repair, maintenance and cleaning work should be carried out with the tractor's engine switched off and the ignition key removed.
- Regularly check the condition of the screw and nut connections.
- Regularly check the technical condition of the connections and the hydraulic conduits. There must not be any leaks of hydraulic oil.
- During the warranty period, any repairs may only be carried out by a Warranty Service authorised by the manufacturer.
- In the event of any fault or damage whatsoever, do not use the mower until the fault has been corrected. The machine must not be used when not in working order.
- Repair work should be carried out by persons trained and entitled to do so. This work should be carried out using appropriate tools.
- Should it be necessary to change individual parts, use only those parts indicated by the manufacturer. Non-adherence to these requirements may cause danger to the health and the user's and other people's lives, and also damage the machine.
- In the event of work requiring the mower to be raised, use properly certified hydraulic or mechanical lifts for this purpose. After lifting the machine, stable and durable supports must also be used. Work must not be carried out under a machine which has only been raised with a three-point linkage.
- The machine must not be supported using fragile elements (bricks or concrete blocks).
- The paint coating should be cleaned off before beginning welding work. Burning paint fumes are poisonous for people and animals. Welding work should be carried out in a well lit and well ventilated space.
- During welding work pay attention to flammable or fusible elements. If there is a risk that they will catch fire or be damaged, they should be removed or covered with non-flammable material before commencing welding work. The machine must be disconnected from the tractor before commencing electric welding.

- Servicing and repair work should be carried out in line with the general principles of workplace health and safety. In the event of injury, the wound must be immediately cleaned and disinfected. In the event of more serious injuries, seek a doctor's advice.
- After finishing servicing or repair work remove all tools from the machine.
- Damaged, missing or worn cutting knives must be replaced in pairs in order to maintain the balance of the cutting disc.
- In order to reduce the danger of fire the machine must be kept in a clean condition.
- In order to limit occupational risks associated with exposure to noise during mower operation use individual protection (ear protectors).

2.2 DRIVING ON PUBLIC ROADS

- When driving on public roads, respect the road traffic regulations.
- Do not exceed the maximum speed when travelling. Adjust your speed to the road conditions.
- Before beginning travel, the mower must be placed in transport position and raised using the rear three-point linkage system. When parked, the mower should be lowered.
- when preparing the more of the transport check if the tipping cylinder mechanical interlocks are properly engaged and if hydraulic cylinder valves are in CLOSED position.
- During transport disconnect PTO shaft from tractor.
- Do NOT leave tractor driver's seat when the tractor is moving.

2.3 DESCRIPTION OF MINIMAL RISK

Pronar Sp. z o. o. in Narew has made every effort to eliminate the risk of accidents. There is, however, a certain minimal risk which could lead to an accident, and this is connected mainly with the actions described below:

- using the machine for purposes other than those for which it is intended,

- operation of the machine by persons under the influence of alcohol,
- being between the tractor and the machine while the engine is running and when the machine is being hitched,
- operating the machine with removed or faulty safety guards,
- not keeping a safe distance from the danger zone or being within the zones while the mower is operating,
- being on the machine while the engine is running,
- cleaning, maintenance and technical checks when tractor's engine is running;
- making modifications to the machine without the consent of the Manufacturer,
- oil leaks and sudden movement of elements resulting from conduit cracking,
- using unreliable PTO shaft,





The minimal risk may be kept to a minimum by following the recommendations below:





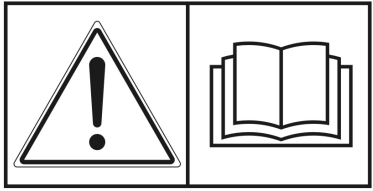

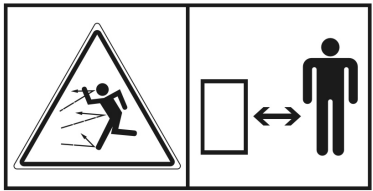
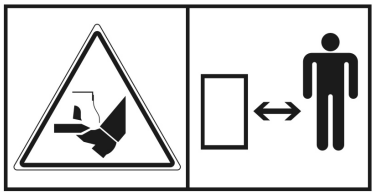
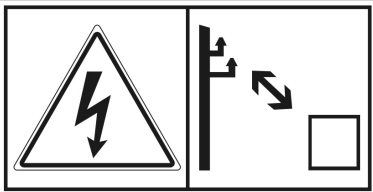
- prudent and unhurried operation of the machine,
- application of the remarks and recommendations contained in the Operator's Manual;
- keeping a safe distance from the danger zone;
- a ban on being on the machine when it is operating,
- carrying out repair and maintenance work in line with operating safety rules;
- using suitable protective clothing;
- ensuring unauthorised persons have no access to the machine, especially children.

2.4 INFORMATION AND WARNING DECALS

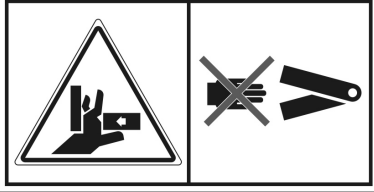
All signs should always be legible and clean, visible to the operator and also to persons possibly being in the vicinity of working machine. If any safety sign is lost or illegible, it should be replaced with a new one. All elements having safety signs replaced during repairs should be affixed with these signs. Safety signs and decals may be purchased from the manufacturer or the Seller.

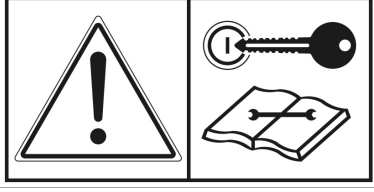
TAB. 2.1 INFORMATION AND WARNING DECALS

ITEM	SYMBOL	DESCRIPTION
1		<p>Before starting work, carefully read the Operator's Manual.</p>
2		<p>Risk of injury when machine is being arranged in transport or working position</p>
3		<p>Thrown out objects, endanger the whole body. Keep a safe distance from the operating machine.</p>
4		<p>Risk of injury to foot or leg. Keep a safe distance.</p>
5		<p>Keep a safe distance from electric power lines.</p>
6		<p>Danger - cutting elements! Do NOT approach an operating machine.</p>
7		<p>Do not touch any rotating elements until they come to a complete standstill.</p>

ITEM	SYMBOL	DESCRIPTION
8		<p>Danger associated with the rotating PTO shaft.</p>
9		<p>Do not reach into crushing space because elements may move. Danger of crushing hands or fingers.</p>
10		<p>Maximum allowable PTO shaft rotation speed is 540 rpm.</p>
11		<p>Before beginning servicing or repairs, switch off engine and remove key from ignition</p>
12		<p>Do not stand behind the tractor while lifting arm is operated.</p>
13		<p>Transport catch point marking.</p>
14		<p>Lubrication points</p>
15	<p>PDT250 PRONAR</p>	<p>Machine type</p>

Numbers in the item column correspond to decals (FIG. 2.1A)

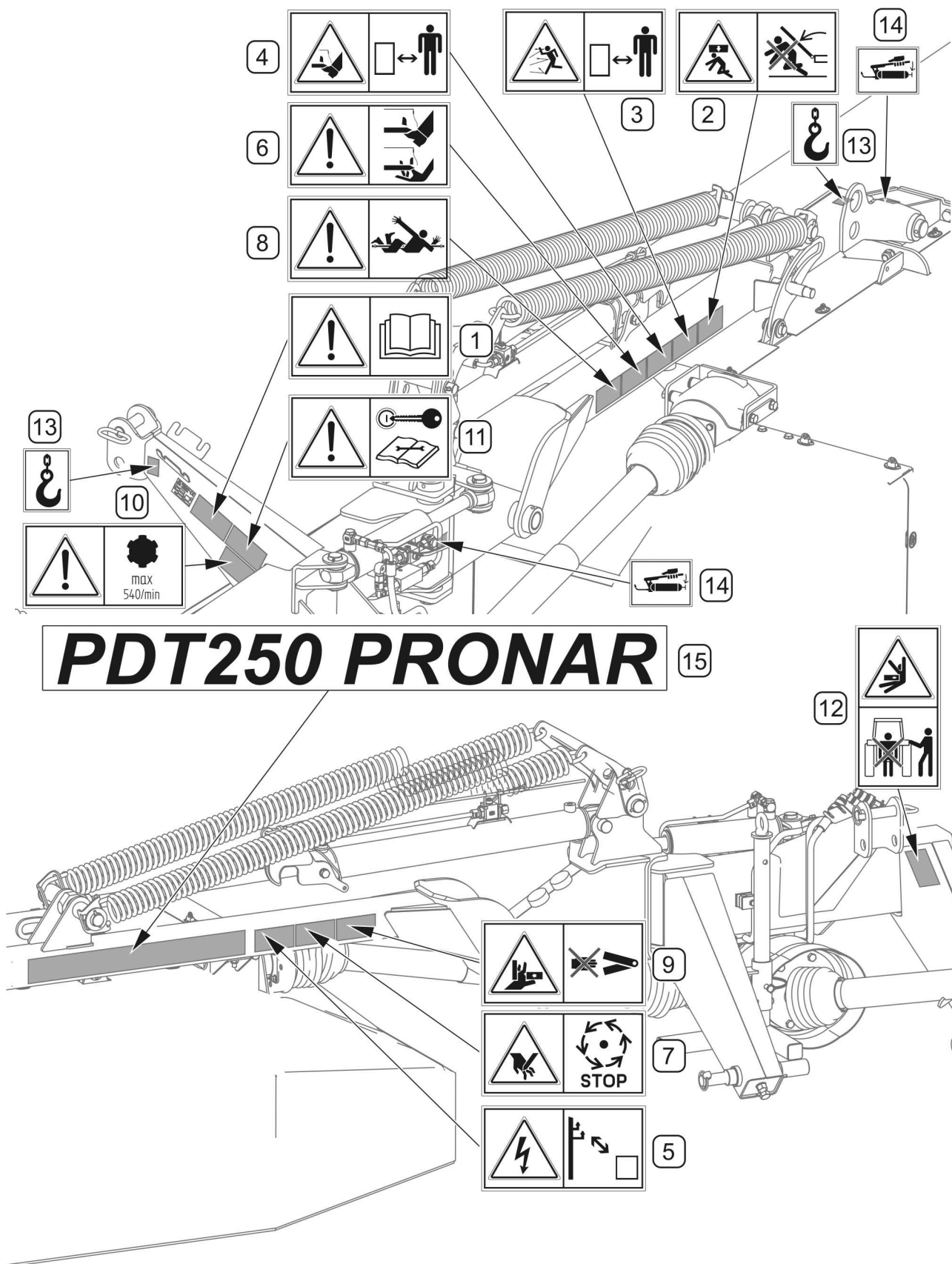

FIG. 2.1A LOCATIONS OF INFORMATION AND WARNING DECALS.

Meaning of symbols (TAB. 2.1)

SECTION

3

**DESIGN AND
OPERATION**

TECHNICAL SPECIFICATION

GENERAL DESIGN

LINKAGE

HYDRAULIC SYSTEM

DRIVE TRANSMISSION

CUTTING UNIT

3.1 TECHNICAL SPECIFICATION

TAB. 3.1 BASIC TECHNICAL SPECIFICATION

	Unit	
Dimensions		
Total width in working setting	mm	4 300
Total height in working setting	mm	1,100
Total length in working setting	mm	1,300
Total length in transport setting minimum / maximum	mm	1,400 / 4 000
Width in transport setting: minimum / maximum	mm	1 430 / 1,700
Height in transport setting minimum / maximum	mm	3,100 / 3 400
Technical specification		
Cutting width	mm	2 500
Swath width	mm	1,100 ÷ 1 600
productivity (<i>at recommended sweeping speed</i>)	ha/h	2.5
Tare weight	kg	520
Minimum power demand	kW/KM	30 / 40
Maximum PTO speed	RPM	540
PTO torque tractor-mower	Nm	900
Linkage	-	Category II and III according to ISO 730
Number of discs	pcs	6
Number of cutting knives	pcs	12
Rotation speed of discs	RPM	3 180
Recommended mowing speed	km/h	10
Noise emission level:		
L _{pA}	dB	92
L _{Amax}	dB	94

L_{pA} - noise level exposure relating to 8 hour working day. Time averaged acoustic pressure emission level correlated with frequency characteristic A.

L_{Amax} - maximum value of measurement correlated with frequency characteristic A of acoustic power level.

3.2 GENERAL DESIGN

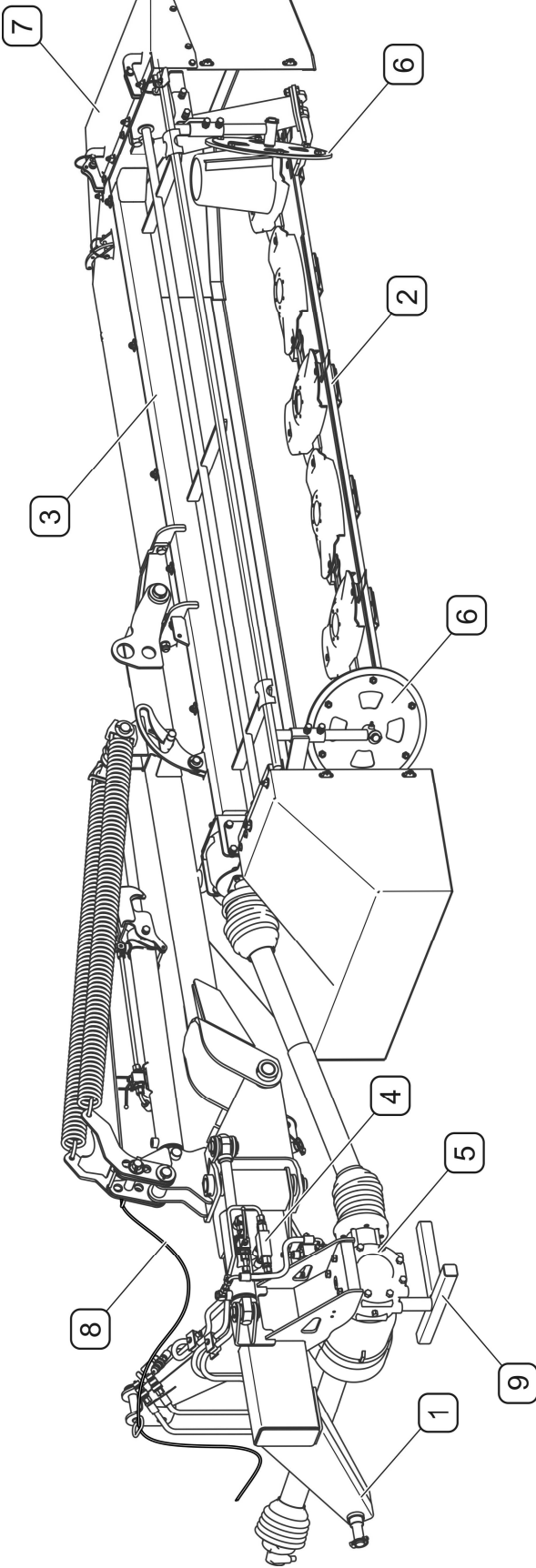

FIG. 3.1A General design

(1)- linkage; (2)- cutting unit; (3)- main frame; (4)- hydraulic system; (5)- drive transmission; (6)- swath guide; (7)- guards; (8)- interlock cable; (9)- support;

3.3 LINKAGE

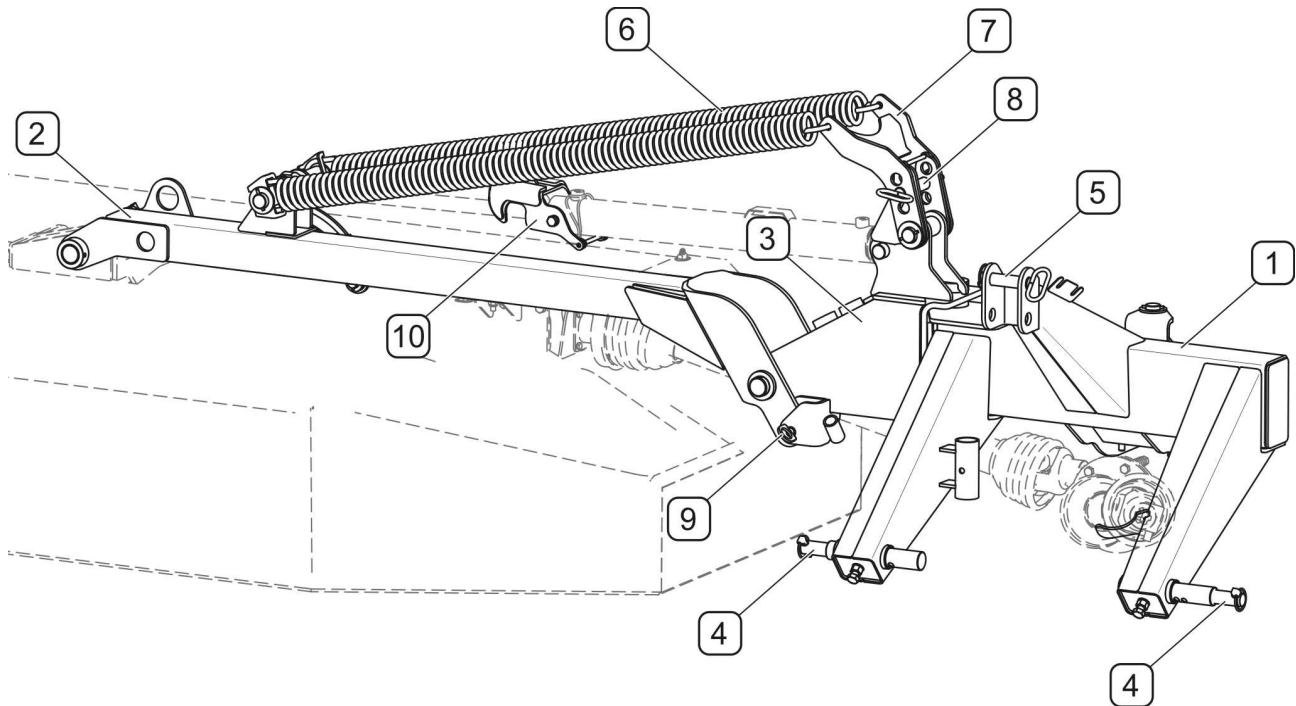

FIG. 3.2A PDT250 mower linkage

(1)- three-point linkage frame; (2)- lifting arm; (3)- moving arm; (4)- three-point linkage lower hitching eye pin; (5)- central connection pin; (6)- stay springs; (7)- spring catch; (8)- spring tensioning pin; (9)- lifting arm interlock pin; (10)- cylinder lock

The main element of the *PDD810* mower linkage (FIG. 3.2A) is the three-point linkage frame (1), equipped with two lower pins (4) and upper pin (5) for connection to the tractor's rear three point linkage. Moving arm (3) allows the cutting unit to swing backwards. Lifting arm (2) raises the cutting unit. To relieve the cutting unit, springs (6) are used, whose tension can be adjusted by changing the positioning of the pin (8). Using the pin (9) lifting arm can be interlocked (2) when mower is disconnected from the tractor.

3.4 HYDRAULIC SYSTEM

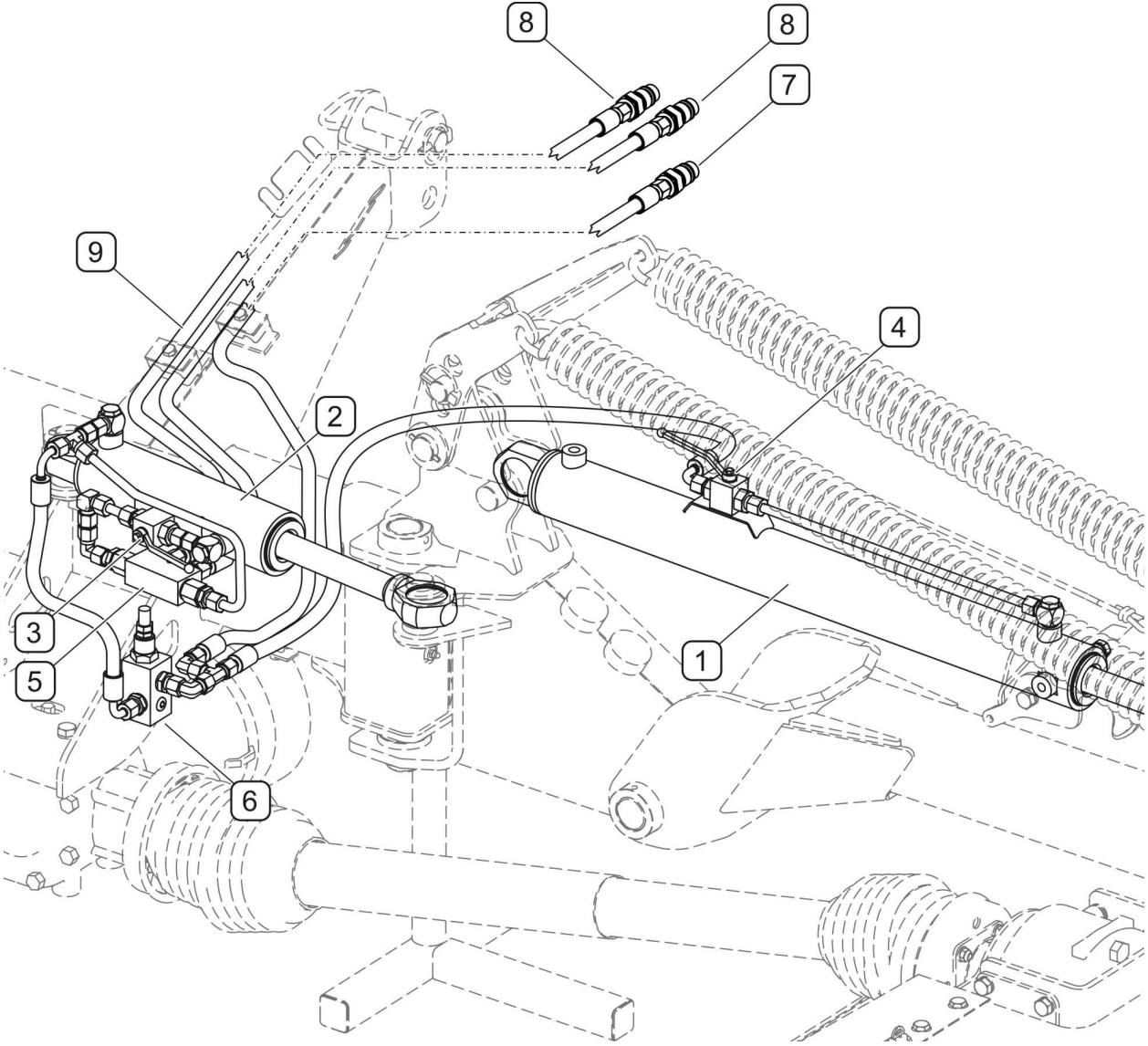

FIG. 3.3A Hydraulic system design

(1) - hydraulic lifting cylinder; (2)- hydraulic tipping cylinder - hydraulic safety device;(3)- tipping cylinder interlocking valve; (4)- lowering cylinder interlocking valve; (5)- hydraulic lock; (6)- overflow valve; (7)- hydraulic quick coupling for lifting control; (8)- hydraulic quick coupling for tipping control; (9)- hydraulic conduits

3.5 DRIVE TRANSMISSION

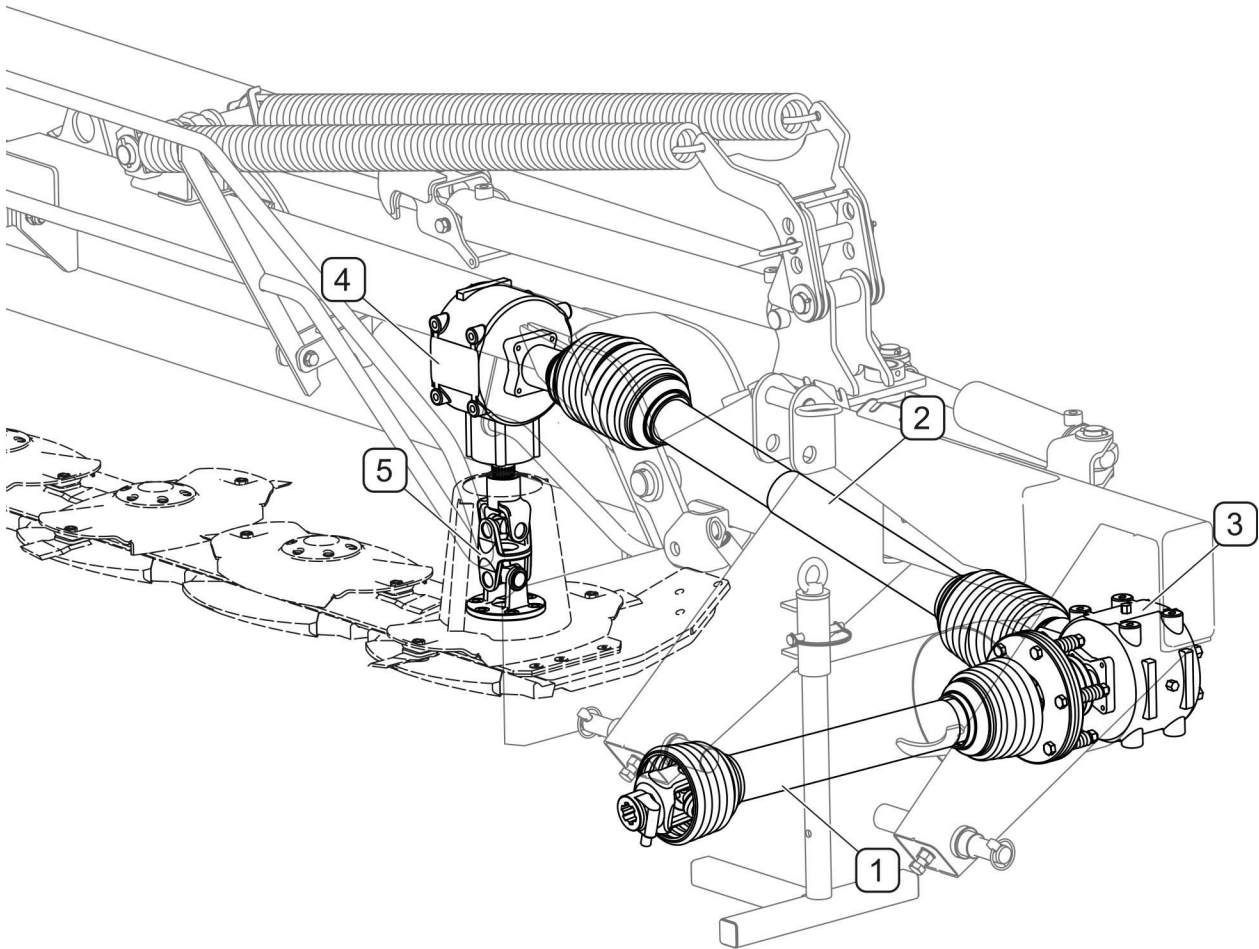

FIG. 3.4A Drive transmission

(1)- PTO shaft with unidirectional overload release clutch; (2)- PTO shaft; (3)- intersecting axis gear I; (4)- intersecting axis gear II; (5)- connector

Torque is transmitted from PTO through a PTO shaft (1) equipped with a friction unidirectional overload release clutch. Next torque from intersecting axis gear (3) using the shaft (2) is transmitted to the intersecting axis gear and then through the connector (5) to the cutterbar.

3.6 CUTTING UNIT

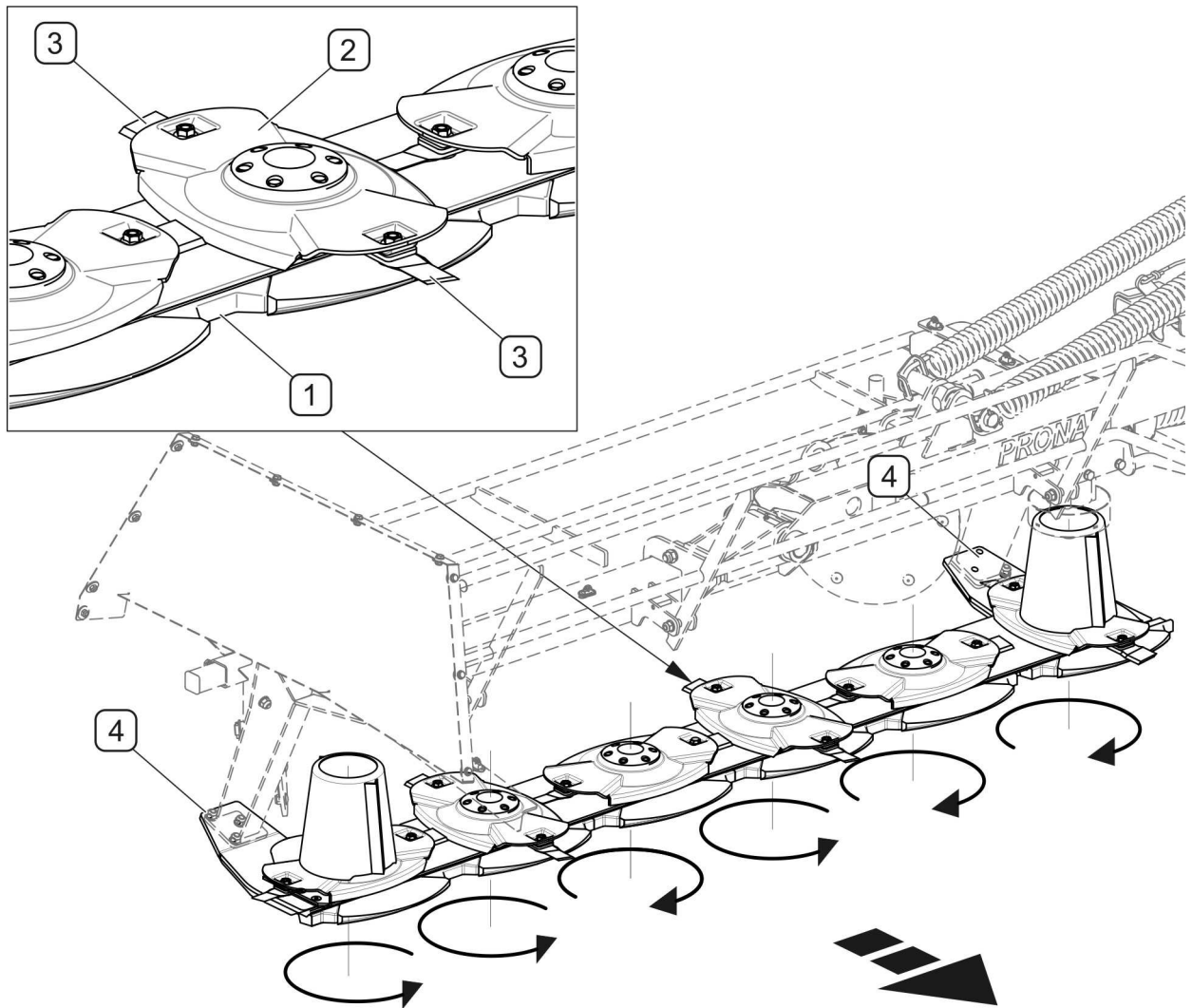

FIG. 3.5A Cutting unit

(1) cutterbar, (2) cutting disc, (3) knife, (4) foot

Cutting unit of the PDT250 mower it comprises the cutterbar (1) on which are mounted six cutting discs (2). The cutterbar is mounted to the frame with the aid of a foot (4). Two cutting knives are mounted on each of the cutting discs, right or left depending on disc rotation direction. Rotation direction of individual discs is shown on figure 3.5A

SECTION

4

CORRECT USE

PREPARING FOR WORK
CHECKING TECHNICAL CONDITION
ATTACHING TO TRACTOR
TRANSPORTING THE MACHINE
SETTING AND MOWING
DISCONNECTING FROM TRACTOR

4.1 PREPARING FOR WORK

The manufacturer guarantees that the machine is fully operational and has been checked according to quality control procedures and is ready for normal use. This does not release the user from an obligation to check the machine's condition after delivery and before first use. The machine is delivered to the user completely assembled.

Before connecting to tractor, machine operator must check the technical condition of the mower and prepare it for test startup. In order to do this:

- the user must carefully read this Operator's Manual and observe all recommendations, understand the design and the principle of machine operation
- check the condition of protective paint coat,
- Inspect machine's individual components for mechanical damage resulting from incorrect transport (dents, piercing, bent or broken components),
- Check all the lubrication points, lubricate the machine as needed according to recommendations provided in section 5 „*MAINTENANCE*”,
- check technical condition of the hydraulic system;
- check if cutting knives, cutterbar, lifting arms and safety guards are correctly installed,
- check technical condition of hitching system pins and locking linchpins,
- check lubricating oil level in intersecting axis gears.

If all the above checks have been performed and there is no doubt as to the machine's good technical condition, it can be connected to tractor. Start the tractor's engine, check all systems and perform a test run before beginning work. In order to inspect:

- connect the mower to tractor,
- set in working position
- connect PTO shaft to tractor and mower,
- start PTO drive.

Engage mower's drive for 3 minutes and check the following:

- there is no knocking or noise in the drive system arising from scraping or grinding of metal elements,
- whether there is excessive vibration in the cutting unit,
- synchronous rotation of cutting unit,



ATTENTION!

Before using the mower always check its technical condition. In particular check the technical condition of the cutting unit, linkage, drive system, and integrity of protective guards.

The mower's operation at no load should be smooth. Shaking of drive transmission, cutting unit and whole machine is not acceptable, nor is changed noise and vibrations coming from loose nut and bolt connections. After stopping mower, check fastening of cutting knives. Check that gear oil does not leak from reduction gear and cutterbar.



DANGER

Before using the mower, the user must carefully read this operator's manual.

Careless and improper use and operation of the mower, and non-compliance with the recommendations included in this operator's manual is dangerous to your health.

The mower must never be used by persons who are not authorised to drive agricultural tractors, including children and people under the influence of alcohol or other drugs.

Non-compliance with the safety rules of this Operator's Manual can be dangerous to the health and life of the operator and others.

Before starting the mower make sure that there are no bystanders (especially children) or animals in the danger zone (an area with a radius of up to 50 m from the mower).

If any faults are detected they must be identified and rectified. If a fault cannot be rectified or the repair could void the guarantee, please contact retailer for additional clarifications.

4.2 CHECKING TECHNICAL CONDITION

When preparing the mower for normal use, check individual elements according to guidelines presented in table (4.1)

TAB. 4.1 TECHNICAL INSPECTION SCHEDULE

DESCRIPTION	SERVICE OPERATION	FREQUENCY
Condition of safeguards	check the technical condition of safeguards, if complete and correctly mounted.	Daily
check if cutterbar and lifting arm are correctly installed,	check if correctly installed	
Technical condition of cutting knives	Visually inspect and if necessary replace according to section „ <i>CHECKING AND REPLACING CUTTING KNIVES</i> ”	
Check lubricating oil level in intersecting axis gears	For details please refer to section " <i>DRIVE SYSTEM OPERATION</i> "	
Check oil level in cutterbar	For details please refer to section " <i>CUTTERBAR OPERATION</i> "	
Check of all main nut and bolt connections are properly tightened	Torque values should be according to table (5.4)	Every six months
Lubrication	Torque values should be according to table „ <i>LUBRICATION</i> ".	According to table (5.3)



ATTENTION!

Do NOT use unreliable mower.

4.3 ATTACHING TO TRACTOR

The PRONAR PDT250 mower may only be mounted on a tractor fulfilling the requirements contained in table „1.1 AGRICULTURAL TRACTOR'S REQUIREMENTS”.



ATTENTION!

Before using the mower, the user must carefully read the tractor operator's manual.



DANGER

Exercise caution when linking the machine.

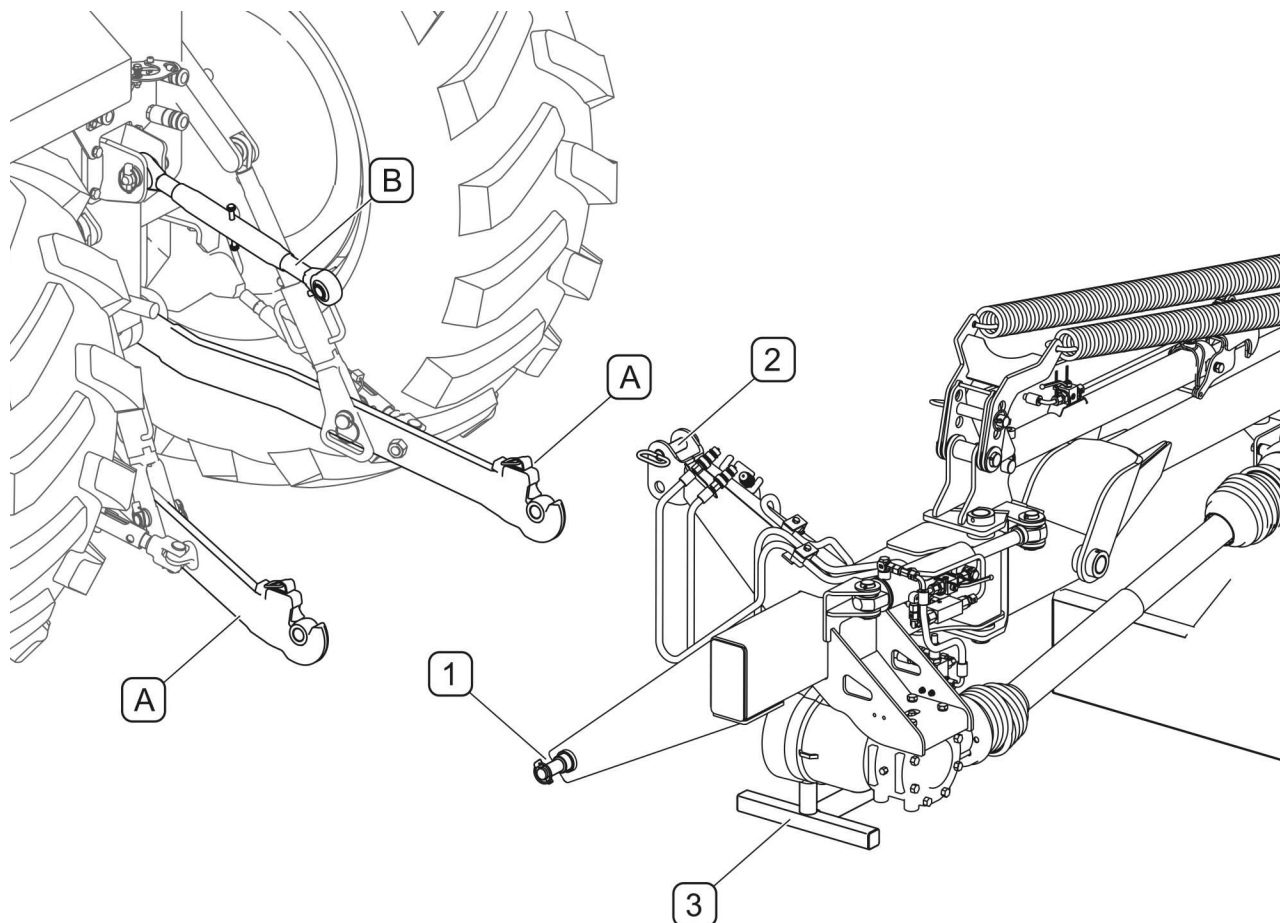



FIG. 4.1A ATTACHING TO TRACTOR

(A)- lower three point linkage arms; (B)- top link; (1)- mower linkage lower pins; (2)- top link mounting pin; (3)- support leg

In order to attach the mower to tractor, perform the following:

- Reversing the tractor bring the lower three point linkage connection points (A) of the tractor close to pins (1) of the mower.
- Set connection arms (A) of tractor at appropriate height.
- Switch off tractor's engine and prevent it from rolling.
- Connect lower pins (1) with linkage arms (A) and lock with the aid of linchpins,
- Connect top link (B) of tractor with pin (2) mower and lock with linchpin.
- Lift mower using tractor's three point linkage.
- Raise support (3) and secure with linchpin.

it is recommended to set both tractor lower linkage arms at the same height.



DANGER

When attaching, there must be nobody between the mower and the tractor.

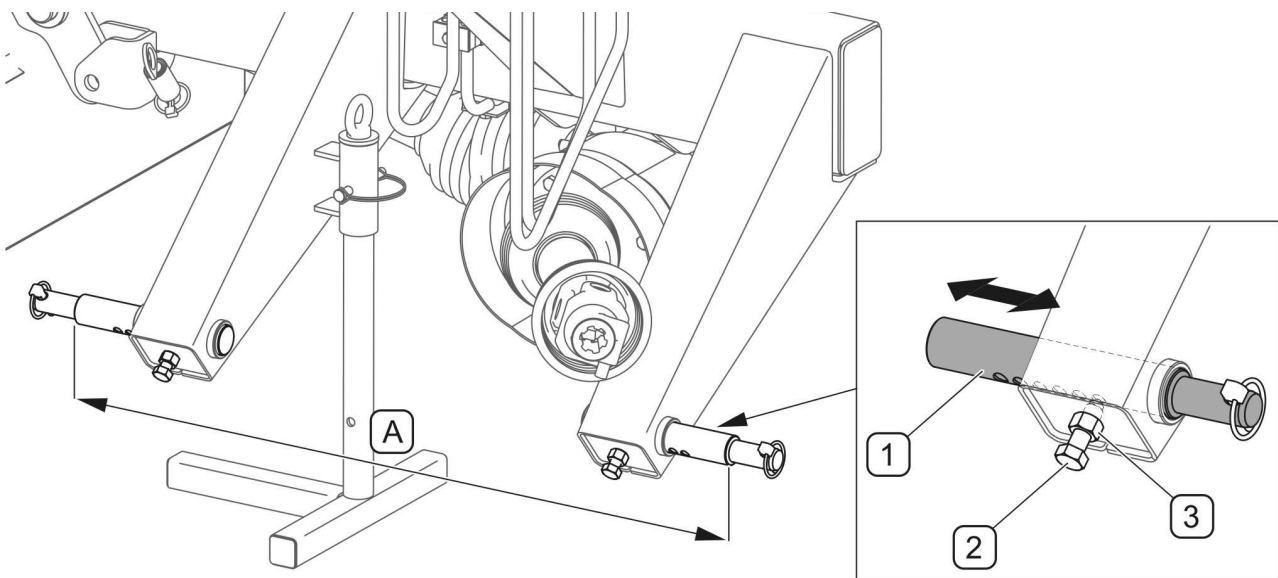

FIG. 4.2A Adjustment of mower lower linkage pins

(A) pin spacing in range $795 \div 970\text{mm}$; (1)- linkage lower pins; (2)- retaining bolt; (3)- counter nut

Lower pins (1) of the mower linkage enable spacing adjustment (FIG. 4.2A) in range 795 ÷ 970 mm. To change spacing of linkage pin spacing:

- loosen counter nut (1),
- unscrew setting bolt (2),
- move pin (1) to the right or the left to obtain the required spacing,
- block pin position with setting bolt (2) and counter nut (3)

The method of adjustment of right and left pins is identical.

As standard PRONAR PDT250 mower is equipped with pins for linking with category II linkage according to ISO 730. To adapt the mower for category III linkage, the optional pins should be used.



ATTENTION!

Comply with the recommendations relating to linkage and mounting points.



DANGER

Prior to connecting hydraulic system conduits the user must carefully read the tractor operator's manual and observe all recommendations of the manufacturer.

Conduit connections of the raising cylinder of the cutting unit lifting frame should be connected to the hydraulic circuit equipped with so-called "floating section". Conduit connections of tipping cylinder of the lifting frame should be connected to double acting hydraulic circuit.



DANGER

When connecting the hydraulic conduits to the tractor, make sure that the tractor's hydraulic system is not under pressure.

4.4 TRANSPORTING THE MACHINE

For transport to place of work and back, raise mower on tractor three point linkage so that the lower pins are at height of not less than 500 mm above the ground. Disconnect PTO shaft from tractor's PTO and place on support.

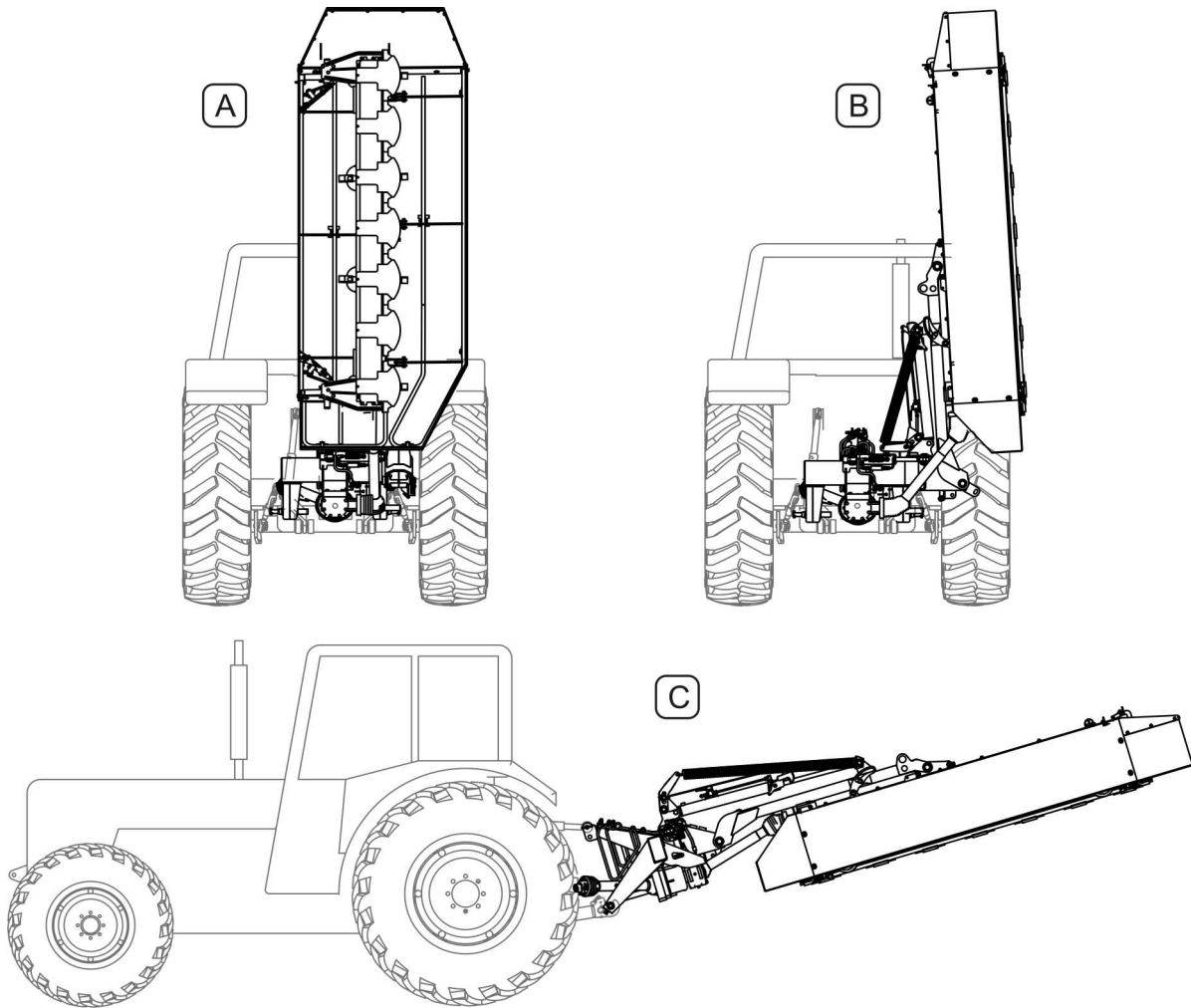

FIG. 4.3A Transport position

(A), (B), (C)- transport positions

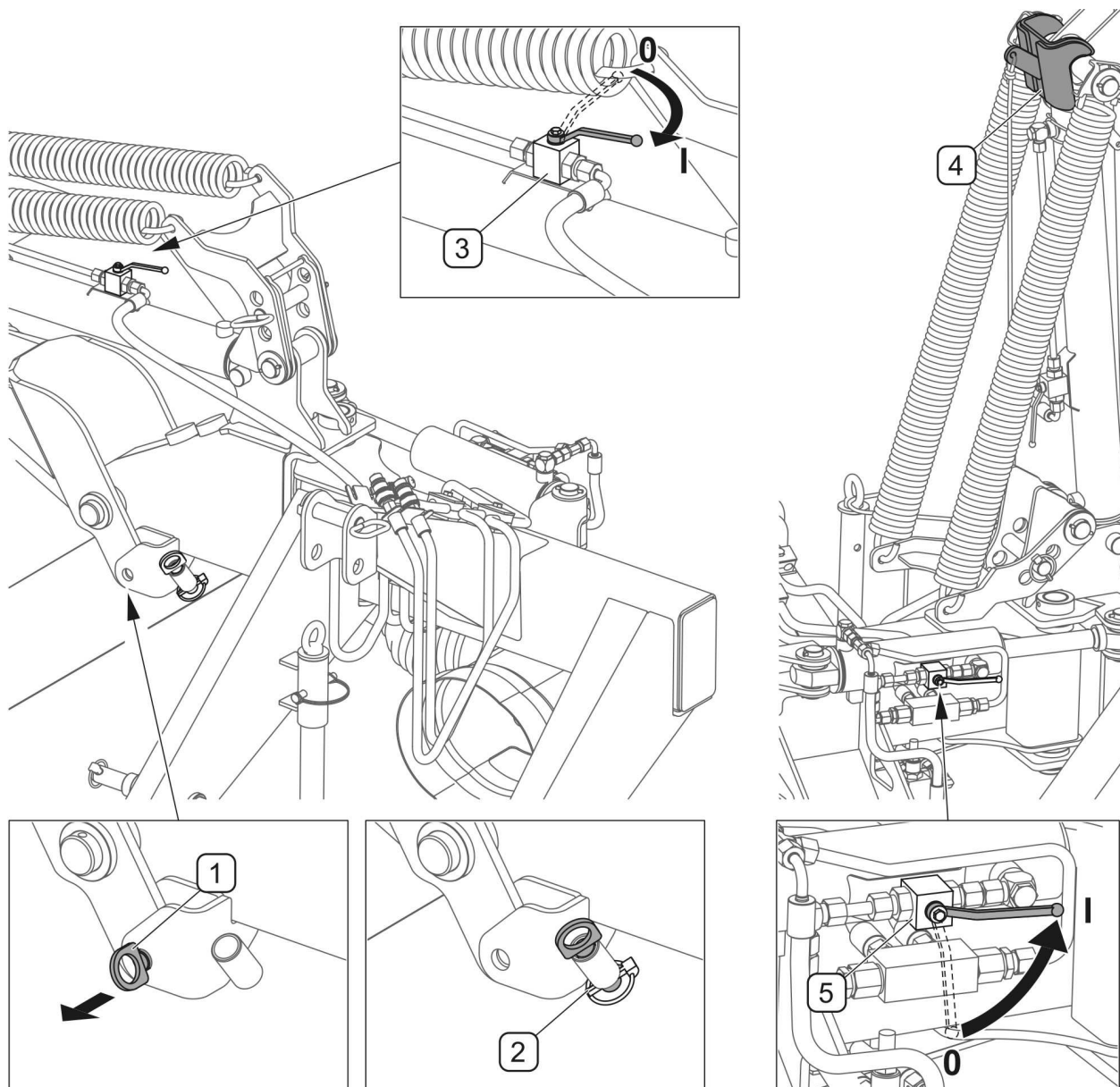

FIG. 4.4A **Setting transport position**

(1)- lifting arm interlock pin; (2)- cotter pin; (3)- lifting arm cylinder interlock valve; (4)- cylinder lock; (5) - tipping cylinder interlock valve; (I)- valve open; (0)- valve closed

The PDT250 can be set in one of three transport positions.

(FIG. 4.3A)

To set the mower in (A) position:

- Release and remove arm interlocked pin (1) (FIG. 4.4A), place it in the sleeve and secure with a cotter pin (2),
- Set cylinder interlock valve (3) in open position „I”
- operating the hydraulic cylinder, lift the lifting arm together with cutting unit until cylinder lock (4) is engaged.
- close lifting cylinder valve (3).

To set the mower in (B) position:

- Perform the procedure listed for (A) position
- set valve (5) in open position „I”
- operating the cylinder, swing the cutting unit backwards,
- close tipping cylinder valve (5).

To set the mower in (C) position:

- Lift the mower on three-point linkage
- set valve (5) in open position „I”
- operating the cylinder, swing the cutting unit backwards,
- close tipping cylinder valve (5).

In (C) transport position in the more it can be transported on short distances only at a reduced travel speed.

Three-point linkage lower arms must be secure so that mower does not swing sideways.



DANGER

When transporting more mounted on the tractor, check if tipping cylinder locks are properly engaged in and if cylinder valves are set in 0 position– closed (FIG. 4.4A)

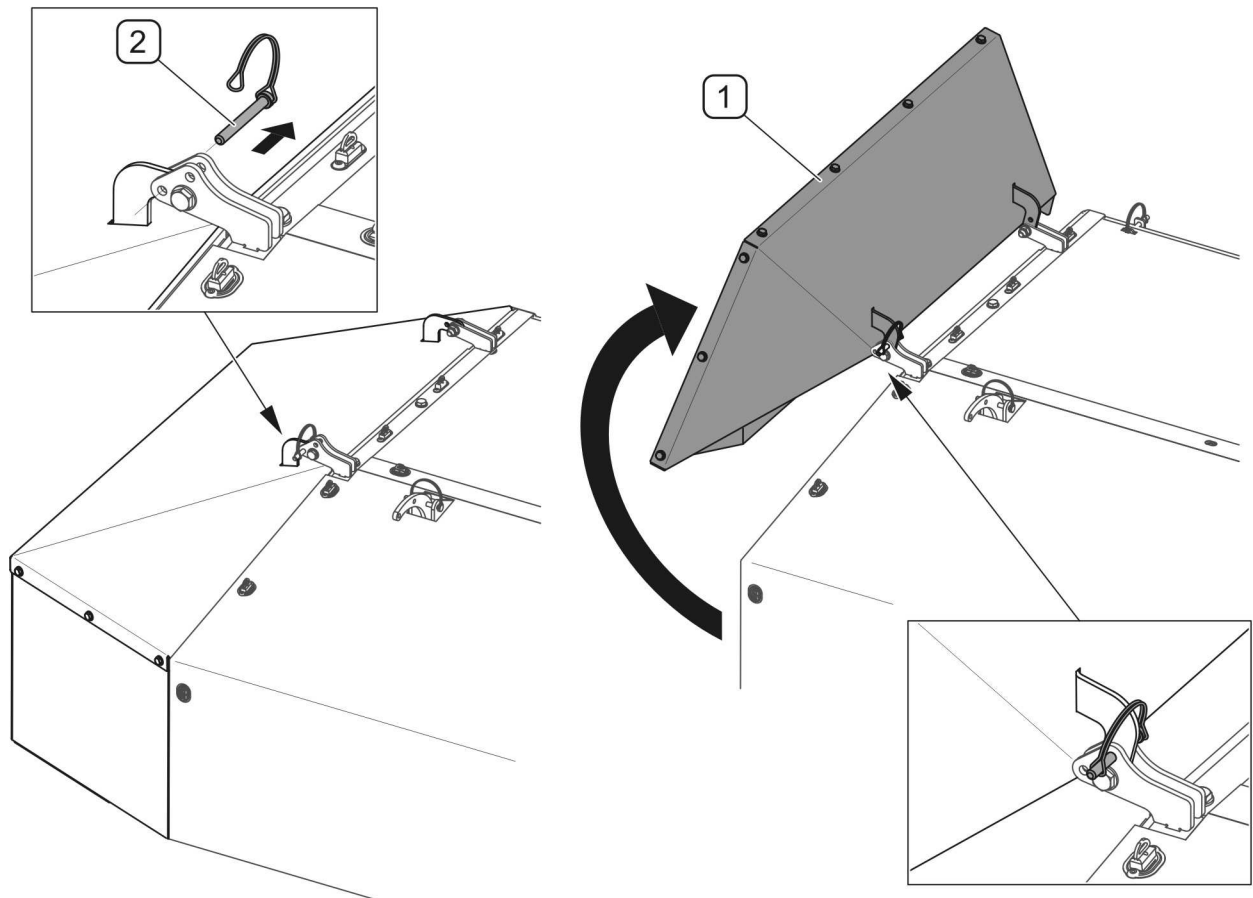

FIG. 4.5A **Cutting unit lateral guard**

(1)- cutting unit lateral guard; (2)- securing pin

In order to reduce the height of mower set in A and B transport positions, open lateral guard (1) before raising the cutting units and lock it in this position. To open the guard:

- release and take out securing pin (2),
- raise side guards (1),
- secure guards open position (2) placing pin in appropriate bracket opening.

4.5 SETTING AND MOWING

4.5.1 SETTING THE MOWER IN WORKING POSITION

To set the mower in working position:

- Set the tipping and lifting cylinders valves (1) and (2) in open position „I” (FIG. 4.6A),
- Controlling appropriate hydraulic circuits in the tractor, maximally extend the tipping cylinder and withdraw the cylinder of the lifting arm.

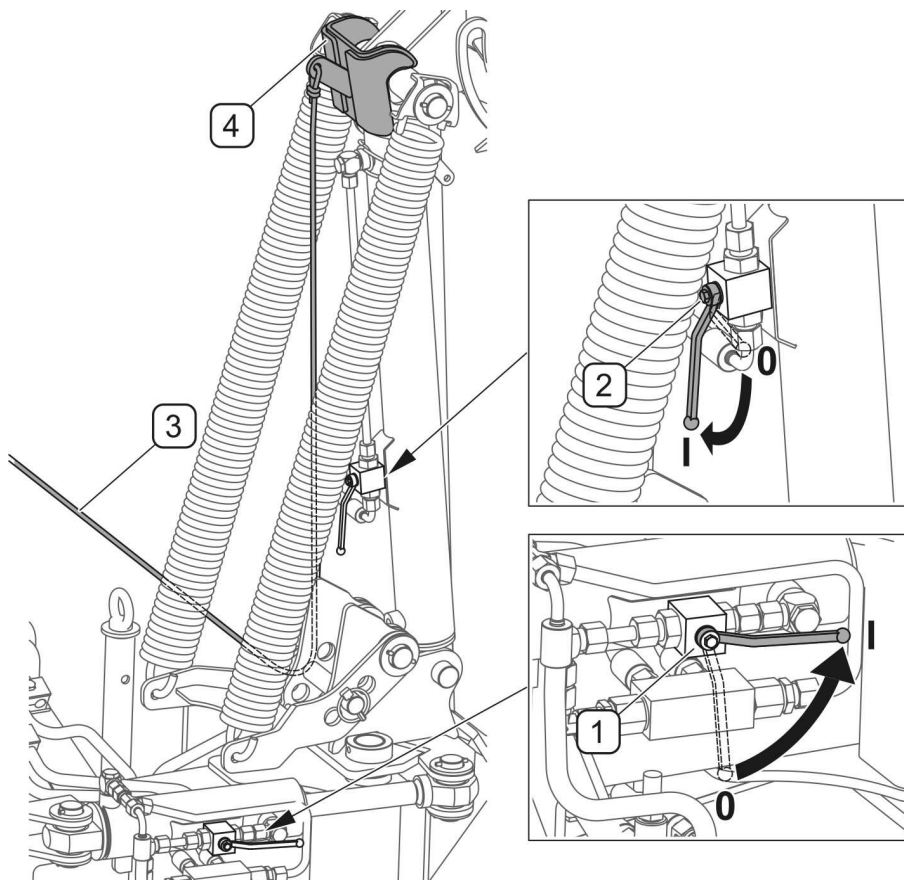

FIG. 4.6A Setting mower in working position

(1)- tipping cylinder interlock valve; (2)- lifting arm cylinder interlock valve;
(3)- cylinder lock cable; (4)- cylinder lock

- Release lock (4) by pulling cable (3) and by operating the tractor's hydraulic circuit, lower lifting arm with cutting unit so that the cutter bar is supported freely on the ground and set tractor's hydraulic circuit in float position,

- set tractor three point linkage at a height of approx. A= 400 mm (FIG. 4.7A) so that the pin is more or less in mid lock range (3).

4.5.2 SETTING CUTTING HEIGHT

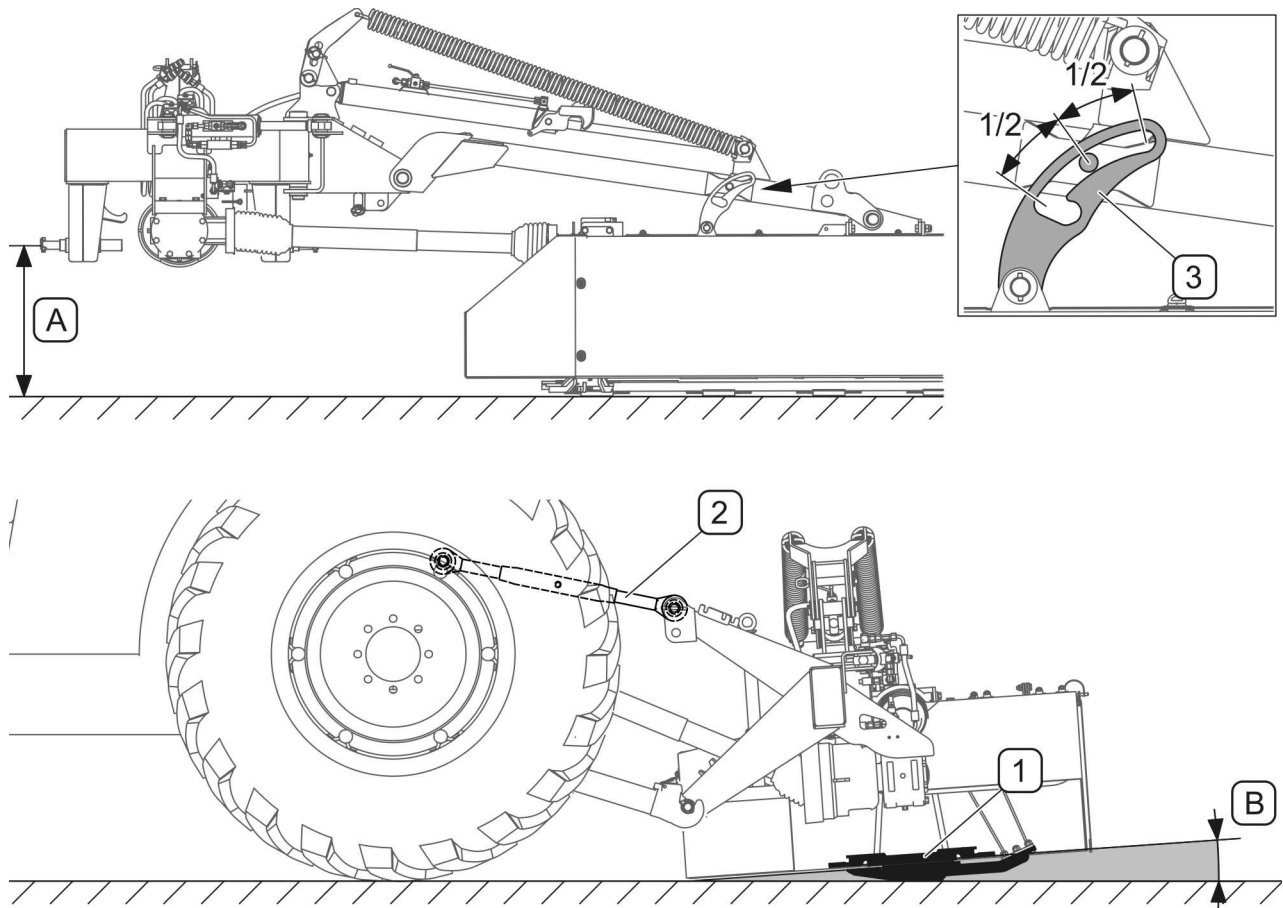

FIG. 4.7A Setting cutting height

(1)- cutterbar; (2)- top link; (3)- lock; (A)- distance of lower link arms from ground - 400mm; (B)- cutterbar inclination $4^{\circ} \div 5^{\circ}$

Once the above is completed adjust the length of the top link (2) saw that angle (A) of cutterbar inclination (1) in relation to the ground is from 4° to 5° (FIG. 4.7A). Cutting height can be set higher by extending the top link (2), or set lower by shortening the top link.



ATTENTION!

Optimum angle of inclination of cutterbar to the front is from 4° to 5° . Inclination to the rear causes faster wearing of cutterbar slide surfaces.

4.5.3 CONNECTING DRIVE SHAFT



DANGER

Before connecting the shaft, turn off the tractor's engine and remove the key from the ignition. Ensure that unauthorised persons do not have access to the tractor.

The use of PTO shaft and its technical condition must be in accord with the Operator's Manual of PTO shaft.

Before connecting the mower it is absolutely necessary to carefully read the Operator's Manual attached by the manufacturer of the shaft and observe the instructions contained in it. Before connection to the tractor check the technical condition of the shaft guard, the completeness and condition of the protecting chains and the general technical condition of the shaft.

The PTO shaft, which connects PTO of the tractor with the mower's intersecting axis gear is equipped with unidirectional overload release clutch. When connecting PTO shaft, its end should be terminated with a clutch (1) and connected to the mower's gear (FIG. 4.8A).

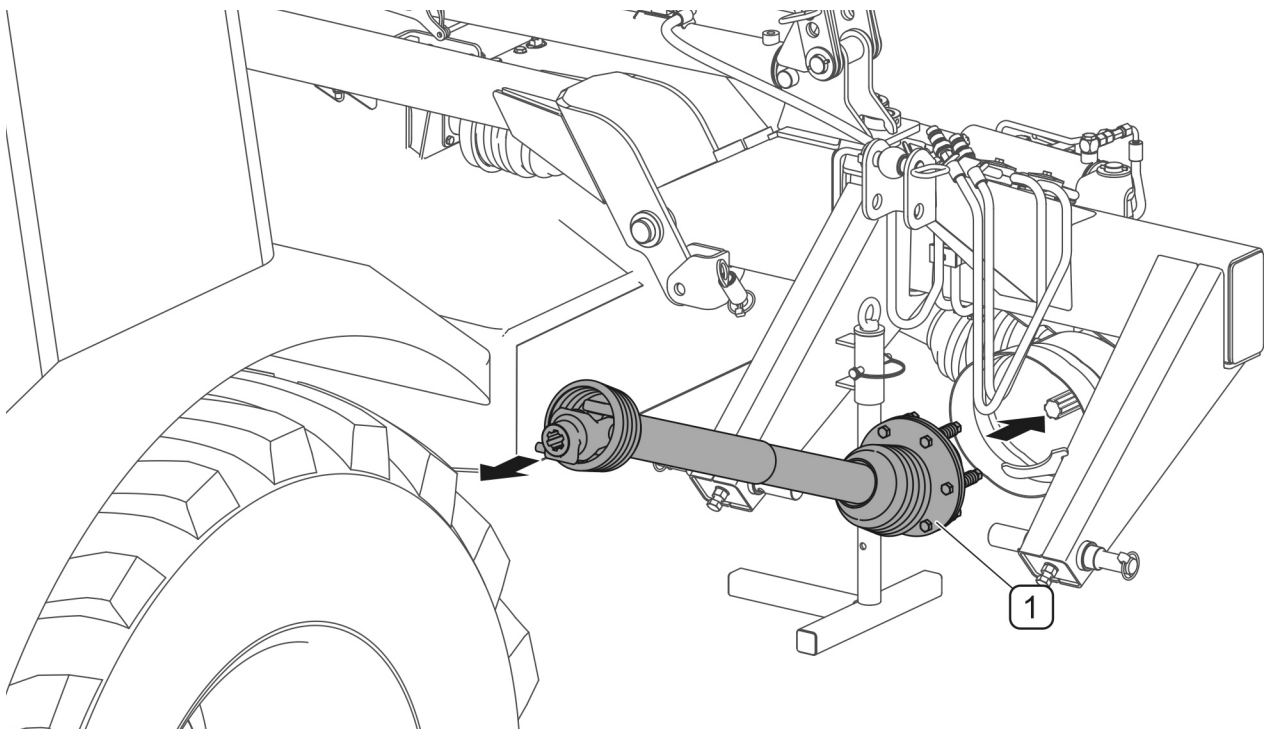

FIG. 4.8A Connecting of PTO shaft

(1)- PTO shaft unidirectional overload release clutch,

Torque value for shaft is set in the factory by the manufacturer and may not be changed by the user. Change of overload protection clutch setting may invalidate the guarantee

PTO shaft collecting both intersecting axis gears does not require installation or dismantling.

4.5.4 STAY SPRING ADJUSTMENT

Stay springs allow for three stage adjustment of cutting unit pressure exerted on the surface. Depending on the type and shape of surface the pressure value may be 70, 80 or 90 kg.

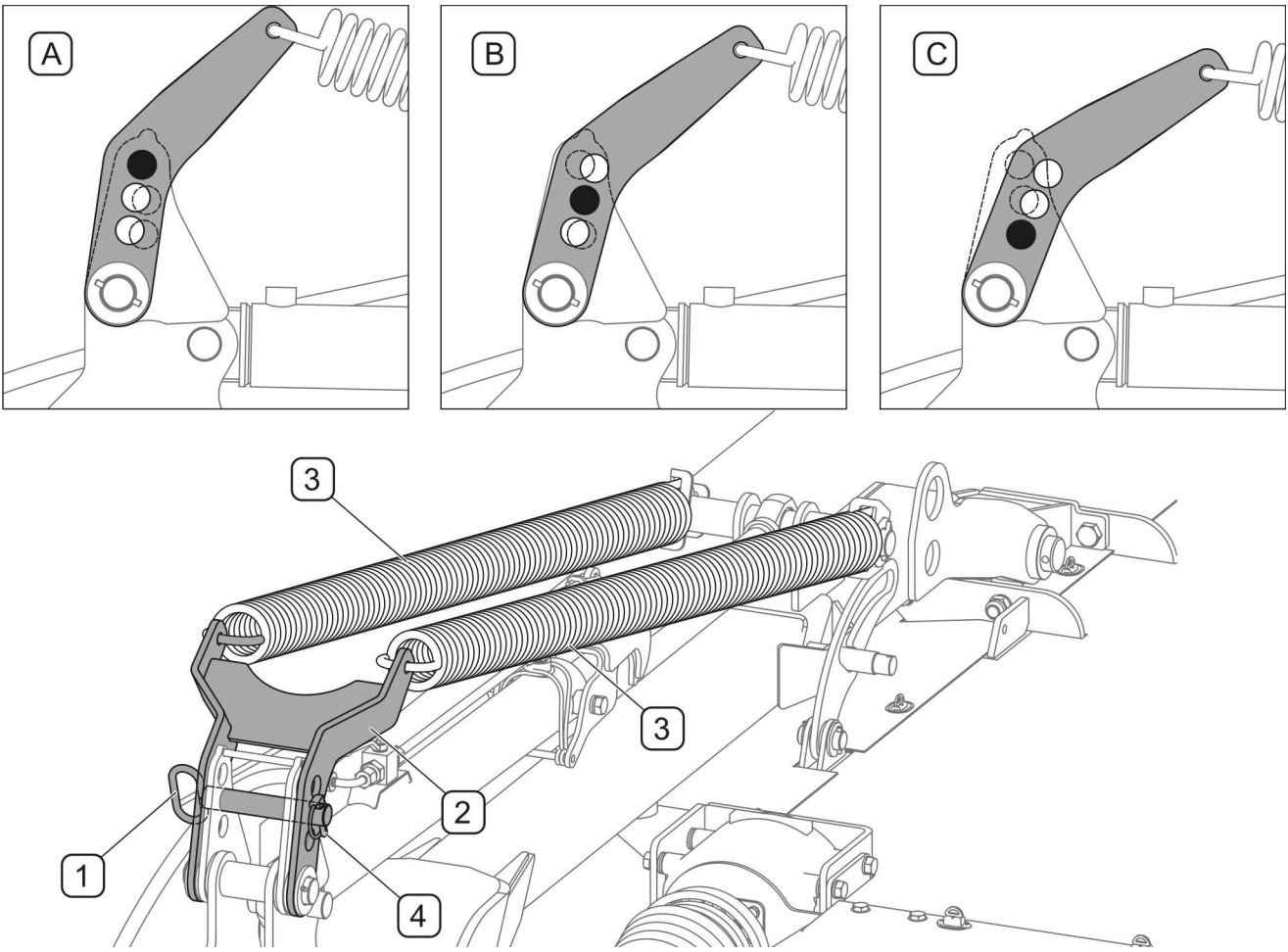

FIG. 4.9A Stay spring adjustment

(A)- pressure setting for 70 kg; (B)- pressure setting for 80 kg; (C)- pressure setting for 90 kg; (1)- locking pin; (2)- spring brackets; (3)- stay springs; (4)- locking pin cotter pin;

To adjust tension of stay springs (FIG. 4.9A):

- raise the lifting arms of the cutting unit to reduce spring loading,
- remove securing linchpin (4) and take out pin (1),
- set bracket accordingly (2), in order to enable insertion of pin (1) in appropriate opening (A, B, or C),
- secure the pin in the chosen position with linchpin (4)

4.5.5 SETTINGS SWATH WIDTH

Two swath guides installed on the cutting unit's support frame are used to adjust the swath width.

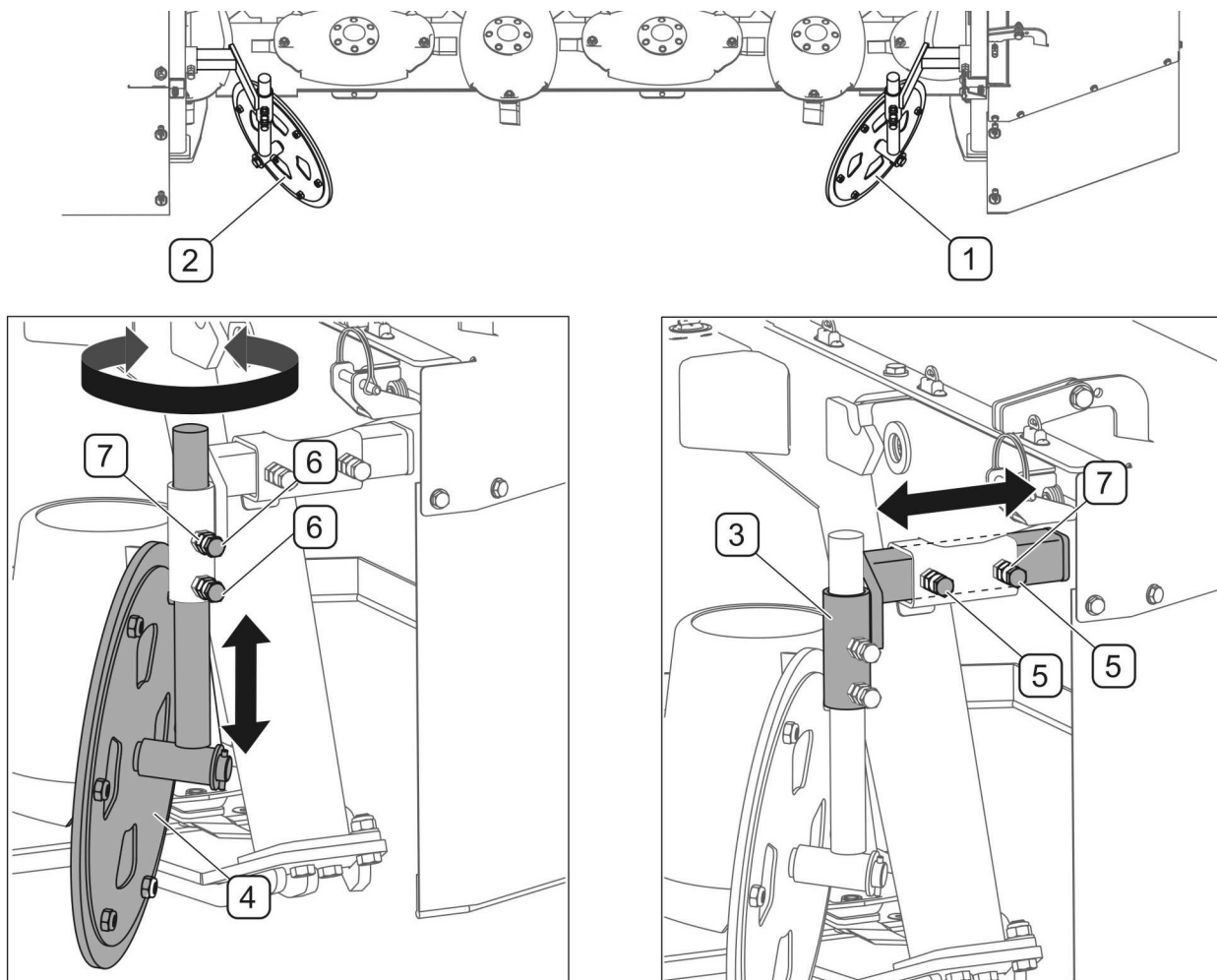

FIG. 4.10A Swath guide adjustment

(1)- right swath guide; (2)- left swath guide; (3)- guide arm;
(4)- disc; (5)- arm adjustment bolts; (6)- disc adjustment bolts; (7)- counter nut

Suitable setting of both swaths guides allows for a stepless adjustment of swath width in the range 1 400 to 1,600 mm. When swath guides are dismantled, swath width is 2 000 mm.

To adjust swath guide position:

- Loosen counter nuts (7) and bolts (5),
- Move arm (3) as required, tighten bolts (5) and secure with counter nuts (7),
- Loosen counter nuts (7) and bolts (6),
- Set the height and angle of the disc (4), tighten bolts (5) and secure with counter nuts (7).

Proceed the same way with the opposite swath guide.

4.5.6 MOWING



DANGER

The mower may only be started when all guards are in place and the cutting unit is set in working position.

Before engaging drive to PTO shaft make sure that there are no bystanders, especially children, near the mower.

Other persons should be at a safe distance (minimum of 50 m) from the mower during work because of the danger that objects may be thrown (stones, branches from beneath rotating disks).

After setting mower in working position, setting cutterbar and stay springs inclination angle, observe the following procedure: Lower the cutterbar lifting arm until the cutterbar rests on the ground.

Engage the PTO in the tractor at a suitably low speed and then gradually increase the speed until PTO speed of 540 rpm is reached. During starting the cutting unit generates considerable noise. Noise is reduced when mower is driven into standing crop. During mowing the lever controlling the cutting unit's hydraulic lifting circuit should be set in "floating" position, however the lever controlling arm inclination (hydraulic safety device) should be set in neutral position.

When mowing pay special attention to uneven surface and any large objects lying in the grass. Mowing speed depends on the quantity and quality of mown crop but also on the type of terrain.

Mowing speed must be reduced if:

- mown ground is uneven,
- crop is laid, or very tall and dense,
- there is a great risk of running into foreign bodies e.g. stones, branches and heaps of soil.

Be especially careful when mowing along ditches, furrows and slopes. When making turns, raise the cutting unit using the lifting cylinder arm without the need to use lifting levers in the tractor. When mowing on hilly terrain or on slopes make turns so that the cutting unit is set up the slope. If during cutting the overload release clutch of the drive shaft is activated, disconnect PTO drive in tractor and check what caused the overload. The overload clutch may be activated because of too low rotation speed of cutting unit.



IMPORTANT!
Do NOT operate mower while reversing.

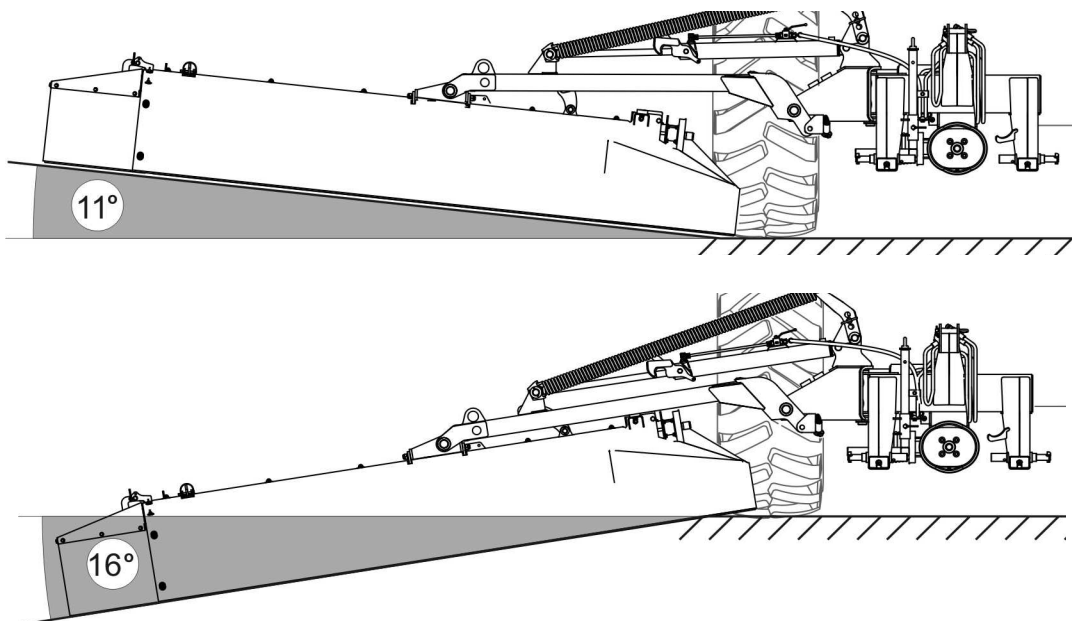

FIG. 4.11A Range of inclination of cutting unit during mowing

4.5.7 HYDRAULIC SAFETY DEVICE

The PDT250 mower is equipped with a hydraulic safety device, which protects the machine against damage resulting from collision with obstacles. When colliding with an obstacle the lifting arm rises and swings backwards. After passing the obstacle the cutting unit returns to the horizontal position and swings forward using the lifting arm inclination

hydraulic cylinder. In order to enable action of the hydraulic safety device, both cylinder valves should be set in open position.

4.6 DISCONNECTING FROM TRACTOR

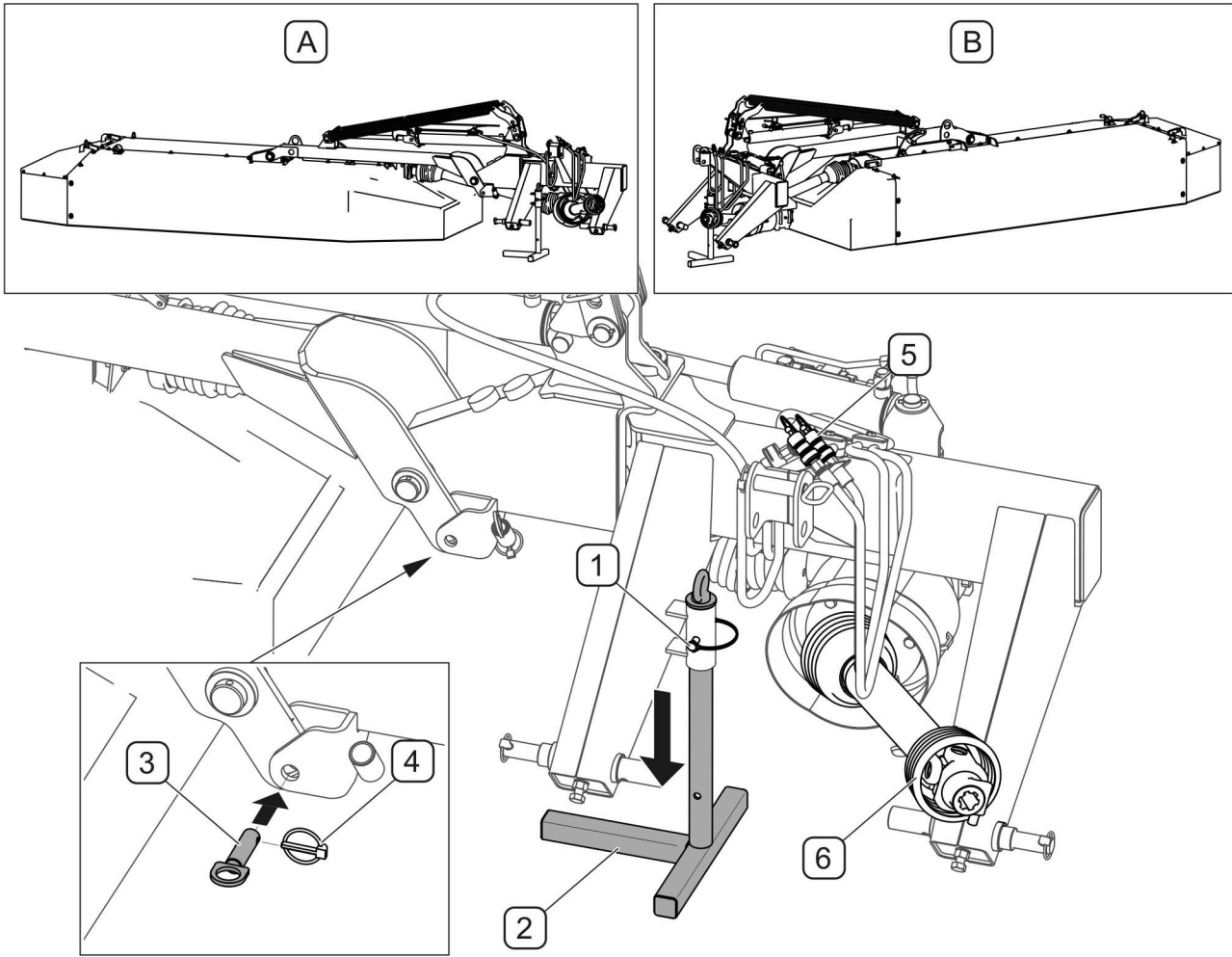

FIG. 4.12A **Disconnecting mower from tractor**

(A),(B)- correct positioning of mower disconnected from tractor (1)- securing pin; (2)- support leg; (3)- interlock pin; (4)- cotter pin; (5)- hydraulic conduit plugs; (6)- PTO shaft;



DANGER

Reduce pressure prior to disconnecting the hydraulic system.



DANGER

Before disconnecting mower from the tractor's linkage, lock the lifting arm in parking position using pin (3) and cotter pin (4) (FIG. 4.12A). Do not disconnect mower from tractor before lifting arm is interlocked.

In order to disconnect the mower from the tractor perform the following:

- set cutting unit in an appropriate position (A) or (B)
- remove securing pin (1) and lower support leg (2);
- lower mower using three-point linkage to rest position,
- switch of tractor engine and remove key from ignition,
- Using pin (3) and cotter pin (4) secure lifting arm and parking position;
- reduce residual pressure in the hydraulic system by movement of appropriate lever controlling hydraulic circuit,
- disconnect hydraulic conduit plugs (5) from tractor and secure with stoppers and place in special brackets on mower frame,
- disconnect PTO shaft from tractor's PTO drive (4) and place on special bracket on mower frame,
- disconnect top link of three-point linkage,
- disconnect lower pins and drive tractor away.

When disconnected from tractor, the mower should be set in position (A) or (B) resting on support leg (2) and cutterbar (FIG. 4.12A)

SECTION

5

MAINTENANCE

CHECKING AND REPLACING CUTTING KNIVES

CUTTERBAR MAINTENANCE

DRIVE SYSTEM MAINTENANCE

HYDRAULIC SYSTEM OPERATION

STORAGE

LUBRICATION

TIGHTENING TORQUE FOR NUT AND BOLT CONNECTIONS

FAULTS AND MEANS OF REMEDYING THEM

5.1 CHECKING AND REPLACING CUTTING KNIVES

DANGER



During inspection and replacement of knives, switch off tractor engine and remove the key from the ignition and engage tractor parking brake. Cutterbar must rest on the ground.

Knife inspections must be carried out regularly. Visual inspection involves checking of the knife's blade and mounting. Knives should be worn down uniformly. If a blade is worn down naturally it can be reversed and reinstalled on the cutting desk (this applies to double edged knives). A bent or damaged knife must be replaced with a new one. Cutting knives must be replaced in pairs in order to maintain the balance of the cutting disc. Before proceeding to replace the knives, clean the residue of mown material from the cutter bar.

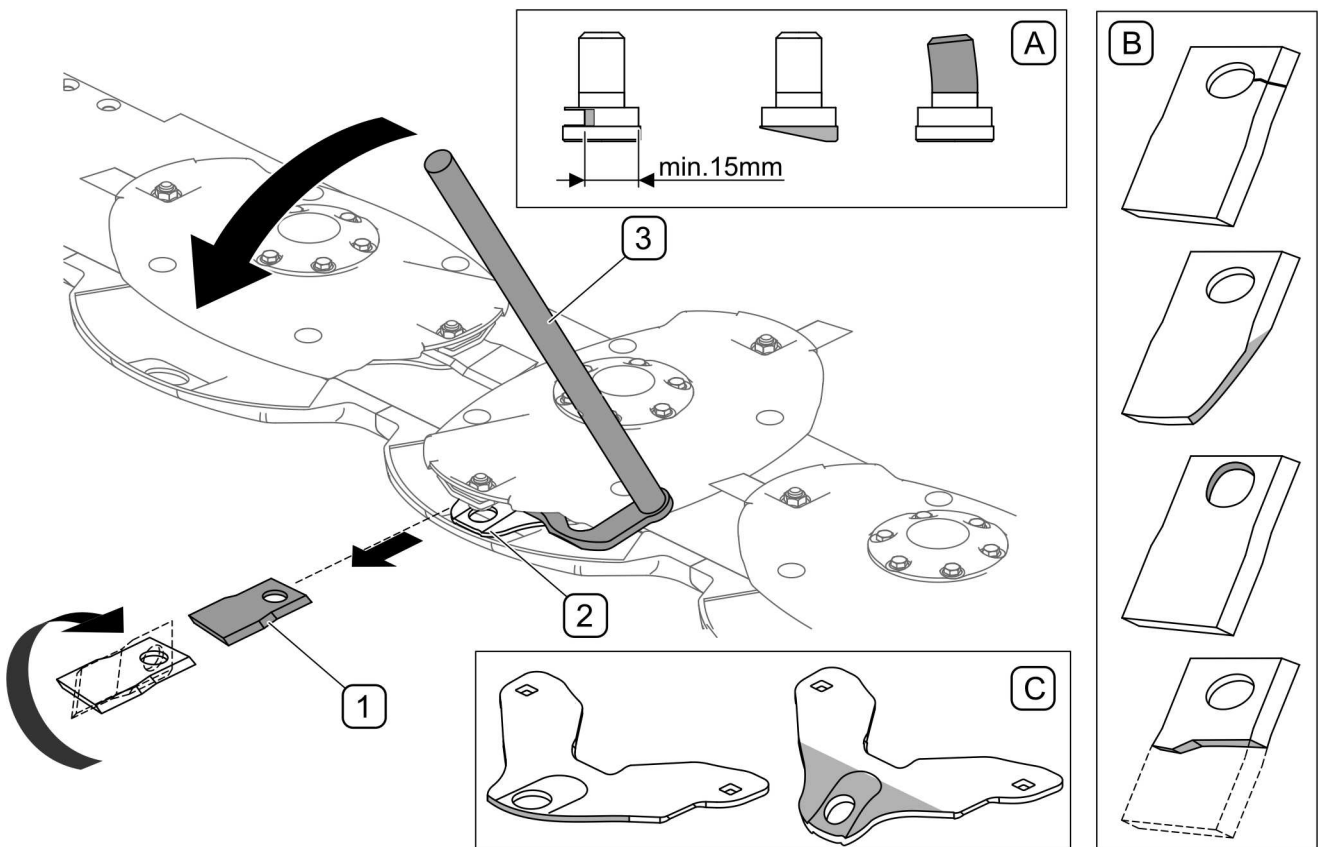

FIG. 5.1A Replacement of cutting knives

- (1)- cutting knife; (2)- knife holder; (3)- knife changing key; (A)- arbor damage example;
- (B)- knife damage example; (C)- knife holder damage example

Use key to change parts (3) placing it between knife holder (2) and cutting disc, next press on key (3) till the moment that it is possible to take out the (1). When changing knives check the condition of the arbor securing the knife to the cutting disc and also the knife holder. An excessively worn or damaged arbor or knife holder should be replaced with a new part. Tighten arbor nuts with torque of 120 Nm.



TIP

Damaged or worn knives must be changed in pairs in order to maintain balance of cutting disc.



ATTENTION!

Missing knife or its fragment will cause imbalance and excessive cutting disk vibration and may damage the cutterbar.



DANGER

Use only CE certified knives meeting the requirements of ISO 5718 standard.

TAB. 5.1 CUTTING KNIFE CHARACTERISTICS

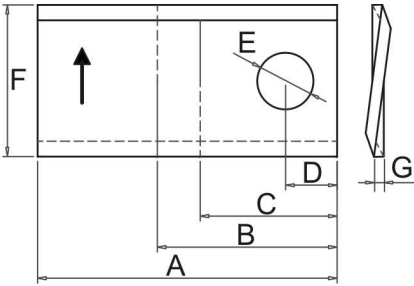
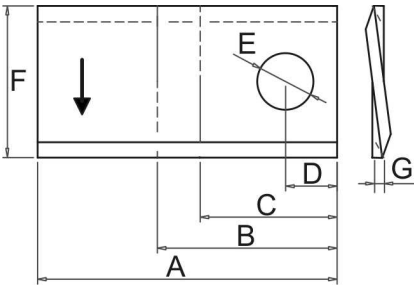
MARKING KNIFE	FIGURE	DIMENSIONS [mm]						
		A	B	C	D	E	F	G
BRZW 100/49/4 P (RIGHT)		100	57	42	20	21	49	4
BRZW 100/49/4 L (LEFT)		100	57	42	20	21	49	4

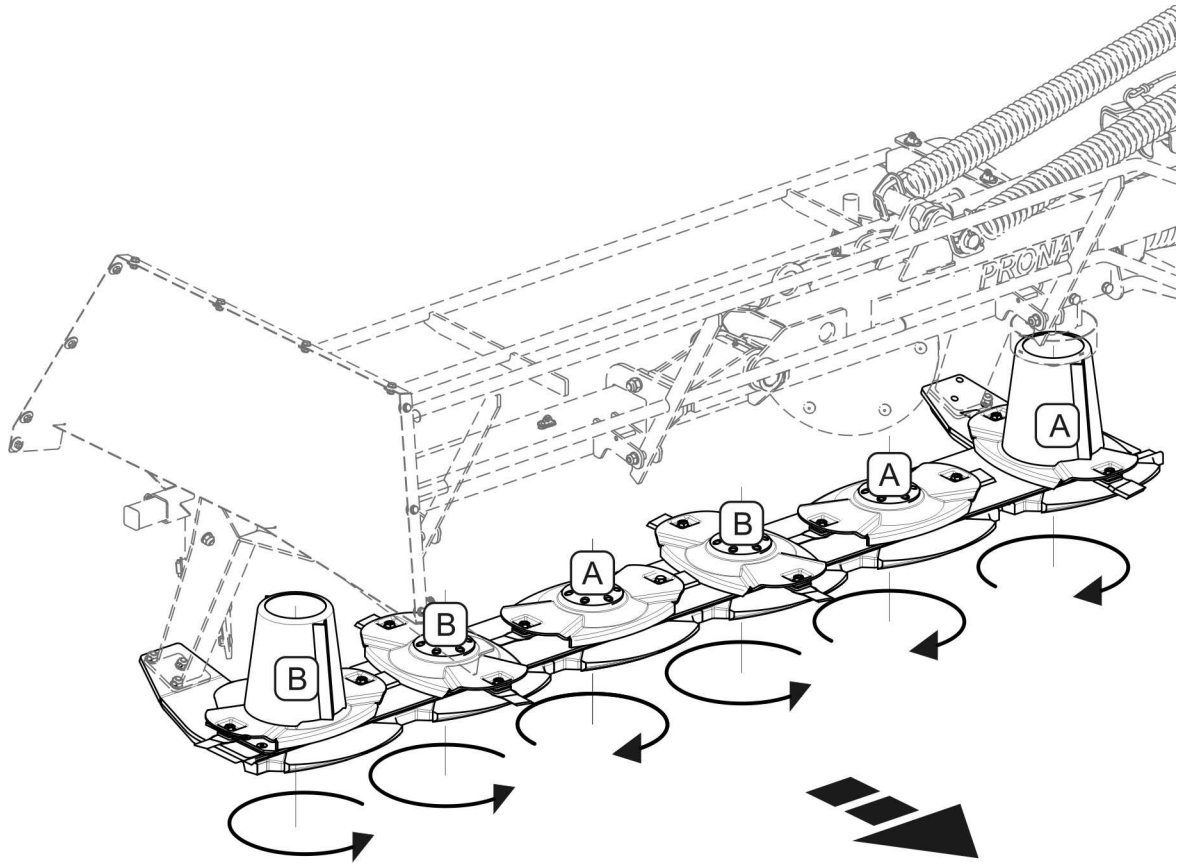

FIG. 5.2A Knife types depending on cutting disc rotation direction

(A)- right knives; (B)- left knives

Due to different cutting disc rotation direction, cutterbar (FIG. 5.2A) is equipped with the right knives (A) and left knives (B). Rotation direction is indicated on the knife.



ATTENTION!

Each time a knife hits an obstacle such as a stone or a branch, its technical condition must be inspected.

5.2 CUTTERBAR MAINTENANCE

Cutting unit maintenance involves periodical checking of oil level and changing of oil in cutterbar.

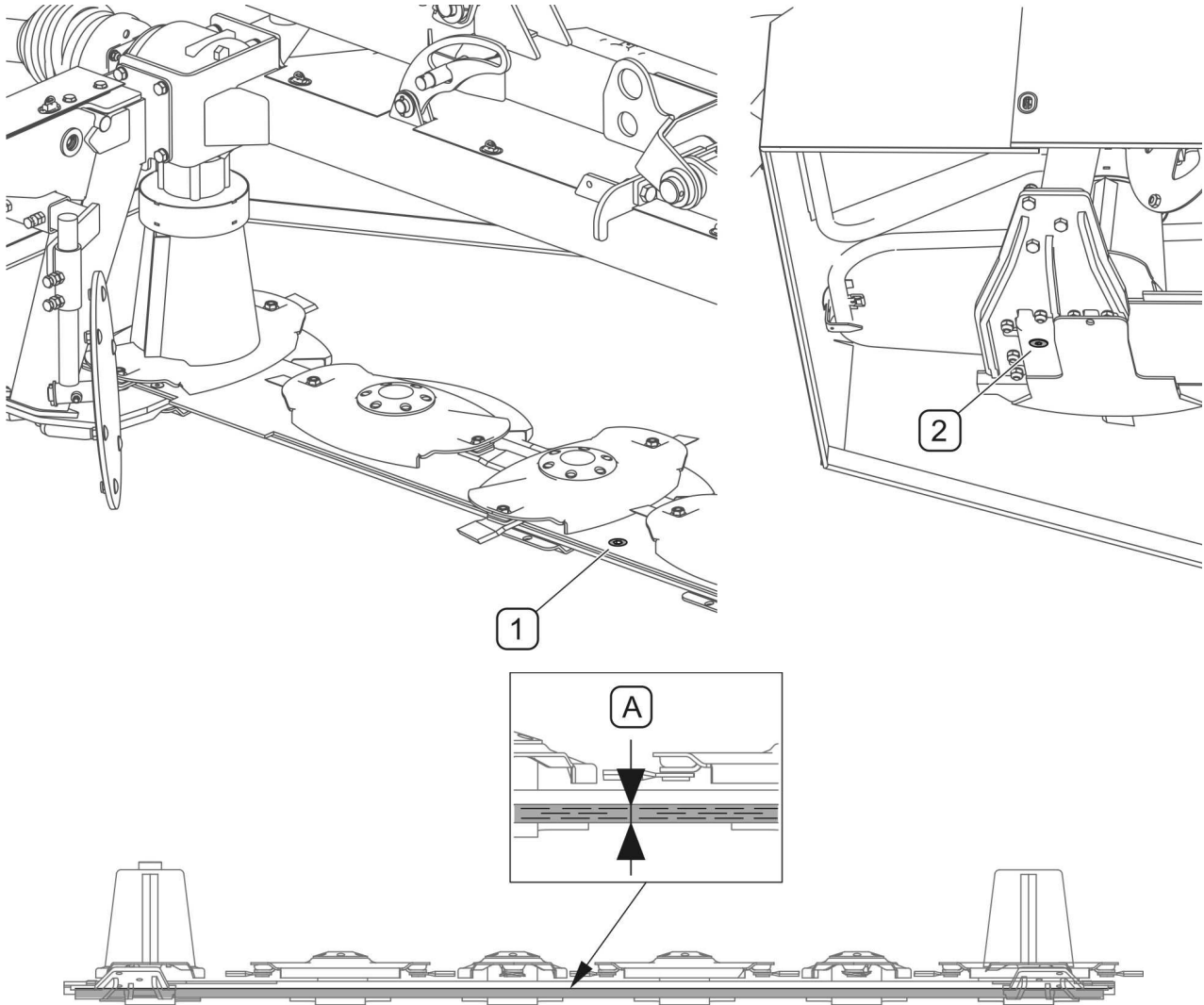

FIG. 5.3A Check oil level in cutterbar

(1)- inlet cap; (2)- drain plug; (A)- correct oil level 5 ÷ 7 mm from the cutterbar bottom

Correct oil level (A) with cutterbar in horizontal position is 5 ÷ 7 mm from the cutterbar bottom. To check oil level remove inlet cap (1) located between the third and fourth disk (FIG. 5.3A). When oil is cold wait approximately 15 minutes before checking the oil level.



Check oil level in cutterbar daily.

First oil change should be made after 50 hours mower operation and then, after each 500 hours of operation or at least once in the season, whichever occurs first. 2,2 litres of SAE90EP gear oil can be poured into cutterbar. It is best to change oil immediately after completing work when cutterbar is still hot and impurities are suspended in oil.

In order to change oil in cutterbar (FIG. 5.3A):

- unscrew inlet plug (1),
- raise cutterbar,
- unscrew drain plug (2) and drain oil to previously prepared basin
- tighten drain plug (2),
- Position cutting unit horizontally and pour the required quantity of oil through the inlet (1),



Oil in cutterbar must be changed after the first 50 hours of work. The next oil change should be made after 500 hours of work or once a year, whichever occurs first.

If a leak is noticed, carefully inspect seals and check oil level. Mower operation with low oil level in cutterbar may cause lasting damage. Repairs of cutterbar during guarantee period (except knife replacement) may only be performed at authorised mechanical workshops.

5.3 DRIVE SYSTEM MAINTENANCE

Drive system maintenance involves periodical checking of oil level and changing of oil in mower's intersecting axis gears.



DANGER

Do NOT perform service repair work under raised and unsupported machine.



Check oil level in intersecting axis gears daily.

To check the oil level in mower intersecting axis gears:

- set mower level horizontally,
- unscrew inspection plug (2),
- oil level should reach the lower edge of the inspection plug opening (2),
- if necessary, supplement oil through inlet opening (1) to the required level.

In the same manner check oil level in the other gear.



DANGER

When checking oil level and changing oil use the appropriate personal protection equipment i.e. protective clothing, footwear, gloves eye protection. Avoid contact of skin with oil.



Oil in both intersecting axis gears must be changed after the first 50 hours of work. The next oil change should be made after 500 hours of work or once a year, whichever occurs first.

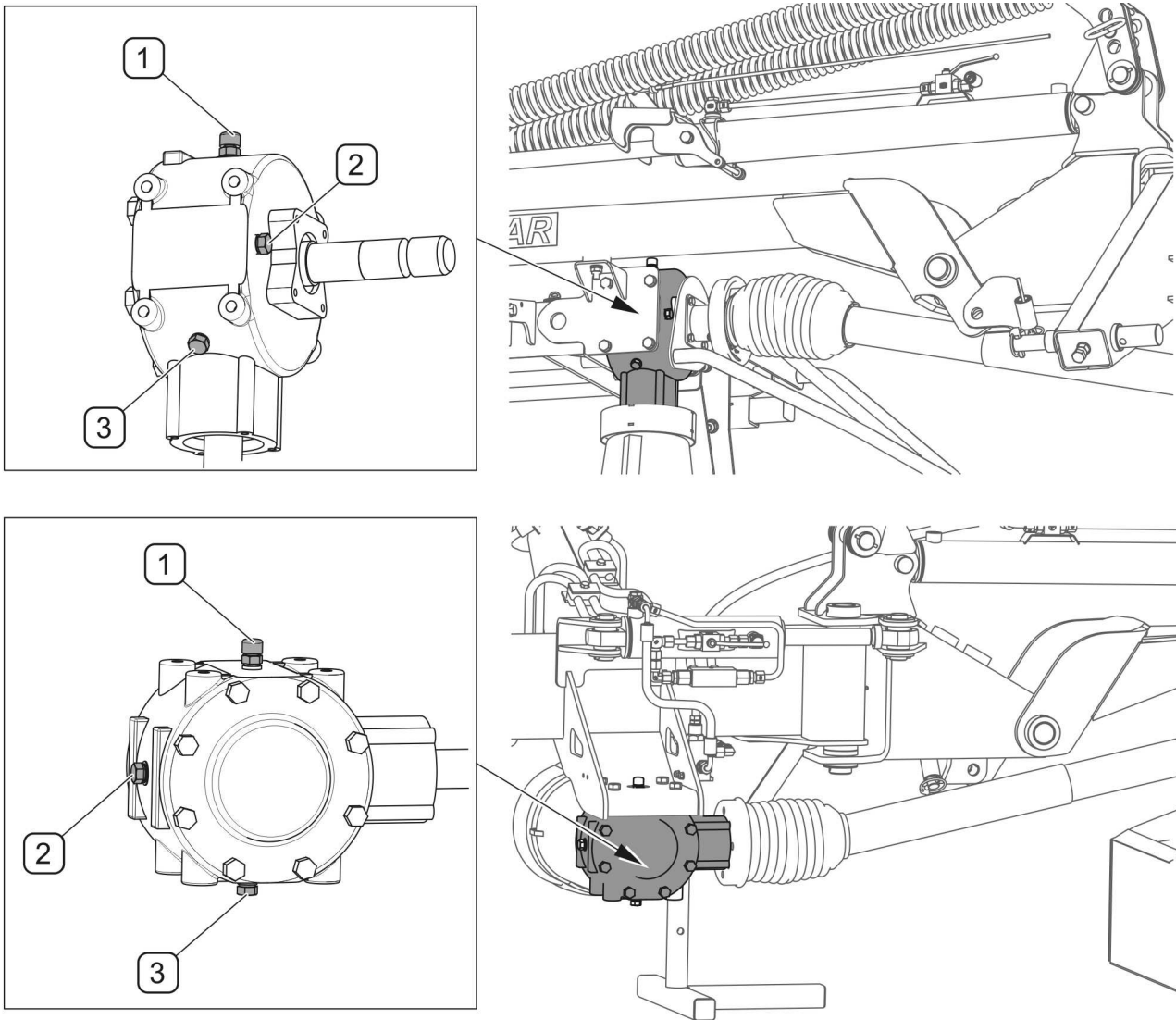

FIG. 5.4A Changing oil in intersecting axis gears

(1) inlet plug, (2) inspection plug, (3) drain plug

To change oil in intersecting axis gear:

- set mower on a hard and level surface
- unscrew inlet plug (1) and inspection plug (2),
- unscrew drain plug (3) and drain oil to previously prepared basin,
- if oil manufacturer recommends flushing transmission gear, that operation should be performed according to the guidelines of the oil manufacturer (relevant information may be indicated on oil packaging),
- tighten drain plug (3),
- add oil until oil flows out of inspection opening (2),
- Tighten inlet and inspection plugs.

Hydraulic oil should be taken to the appropriate facility dealing with the re-use of this type of waste.

To lubricate intersecting axis gears use SAE90EP gear oil in quantity of 1.1 litre for each gear.

If a leak is noticed, carefully inspect seals and check oil level. Transmission operation with insufficient oil may cause permanent damage of the mechanism.

Repair of transmission during guarantee period may only be performed at authorised mechanical workshops.

5.4 HYDRAULIC SYSTEM OPERATION



DANGER

Before commencing whatever work on hydraulic system reduce the pressure in the system.



DANGER

During work on hydraulic systems use the appropriate personal protection equipment i.e. protective clothing, footwear, gloves eye protection. Avoid contact of skin with oil.

Always adhere to the principle that the oil in the mower hydraulic system and in the tractor hydraulic system are the same type. Application of different types of oil is not permitted. In a new mower, the hydraulic system is filled with HL32 hydraulic oil.



ATTENTION!

The condition of hydraulic systems should be inspected regularly while using the machine.

The hydraulic system should be completely tight sealed. Inspect the seals when hydraulic ram cylinders are completely extended. In the event of confirmation of oil on hydraulic ram cylinder bodies ascertain origin of leak. Minimum leaks are permissible with symptoms of "sweating", however in the event of noticing leaks in the form of "droplets" stop using the machine until the fault is remedied.

In the event of confirmation of an oil leak on hydraulic conduit connections, tighten connections, and if this does not remedy faults then change conduit or connection elements. Change of sub assemblies is equally required in each instance of mechanical damage.

TAB. 5.2 HL32 HYDRAULIC OIL CHARACTERISTICS

ITEM	NAME	VALUE
1	ISO 3448VG viscosity classification	32
2	Kinematic viscosity at 40 ⁰ C	28.8 ÷ 35.2 mm ² /s
3	ISO 6743/99 viscosity classification	HL
4	DIN 51502 quality classification	HL
5	Ignition temperature	above 210 ⁰ C

The oil applied because of its composition is not classified as a dangerous substance, however long-term action on the skin or eyes may cause irritation. In the event of contact of oil with skin wash the place of contact with water and soap. Do not apply organic solvents (petrol, kerosene). Contaminated clothing should be changed to prevent access of oil to skin. In the event of contact of oil with eye, rinse with large quantity of water and in the event of the occurrence of irritation consult a doctor. Hydraulic oil in normal conditions is not harmful to the respiratory tract. A hazard only occurs when oil is strongly atomised (oil vapour), or in the case of fire during which toxic compounds may be released. Oil fires should be quenched with the use of carbon dioxide (CO₂), foam or extinguisher steam. Do not use water to quench oil fires.

Oil that escapes from the hydraulic system shall be immediately collected to a clearly marked and sealed container. Hydraulic oil should be taken to the appropriate facility dealing with the re-use of this type of waste.



Flexible hydraulic conduits should be replaced after 4 years of use.

5.5 STORAGE

After finishing work, mower should be thoroughly cleaned and washed with water jet. While washing do not direct a strong water or steam jet at information and warning decals, bearings or hydraulic conduits. Nozzle of pressure or steam washer should be kept at a distance of not less than 30 cm from cleaned surface.

After cleaning, inspect the whole machine, inspect technical condition of individual elements. Used or damaged elements should be repaired or replaced.

In the event of damage to the paint coat, clean rust and dust from damaged area, degrease and then paint with undercoat and after it is dry paint with surface coat paint retaining colour uniformity and even thickness of protective coating. Until the time of touch-up painting, the damaged place may be covered with a thin layer of grease or anticorrosion preparation. Mower should be kept in closed or roofed building.

If the mower shall not be used for a long period of time, protect it against adverse weather conditions. Lubricate mower according to the instructions provided. In the event of prolonged work stoppage, it is essential to lubricate all elements regardless of the period of the last lubrication process. Additionally before the winter period hitching system pins should be smeared with grease.

5.6 LUBRICATION

Machine lubrication should be performed with the aid of a manually or foot operated grease gun, filled with generally available permanent grease. Before commencing lubrication in so far as is possible remove old grease and other contamination. Remove and wipe off excess oil or grease



When using the mower the user is obliged to observe lubrication instructions according to attached schedule. Excess lubrication substance causes depositing additional contaminants in places requiring lubrication, therefore it is essential to keep individual machine elements clean.

Oil gear in cutterbar in accordance with recommendations given in section „5.2 CUTTERBAR MAINTENANCE”. For detailed instructions on how to change oil in intersecting axis gears please refer to section „5.3 *DRIVE SYSTEM MAINTENANCE*”. Lubrication points are shown on figure (5.5A) and detailed in table 5.3 *LUBRICATION POINTS AND LUBRICATION FREQUENCY*

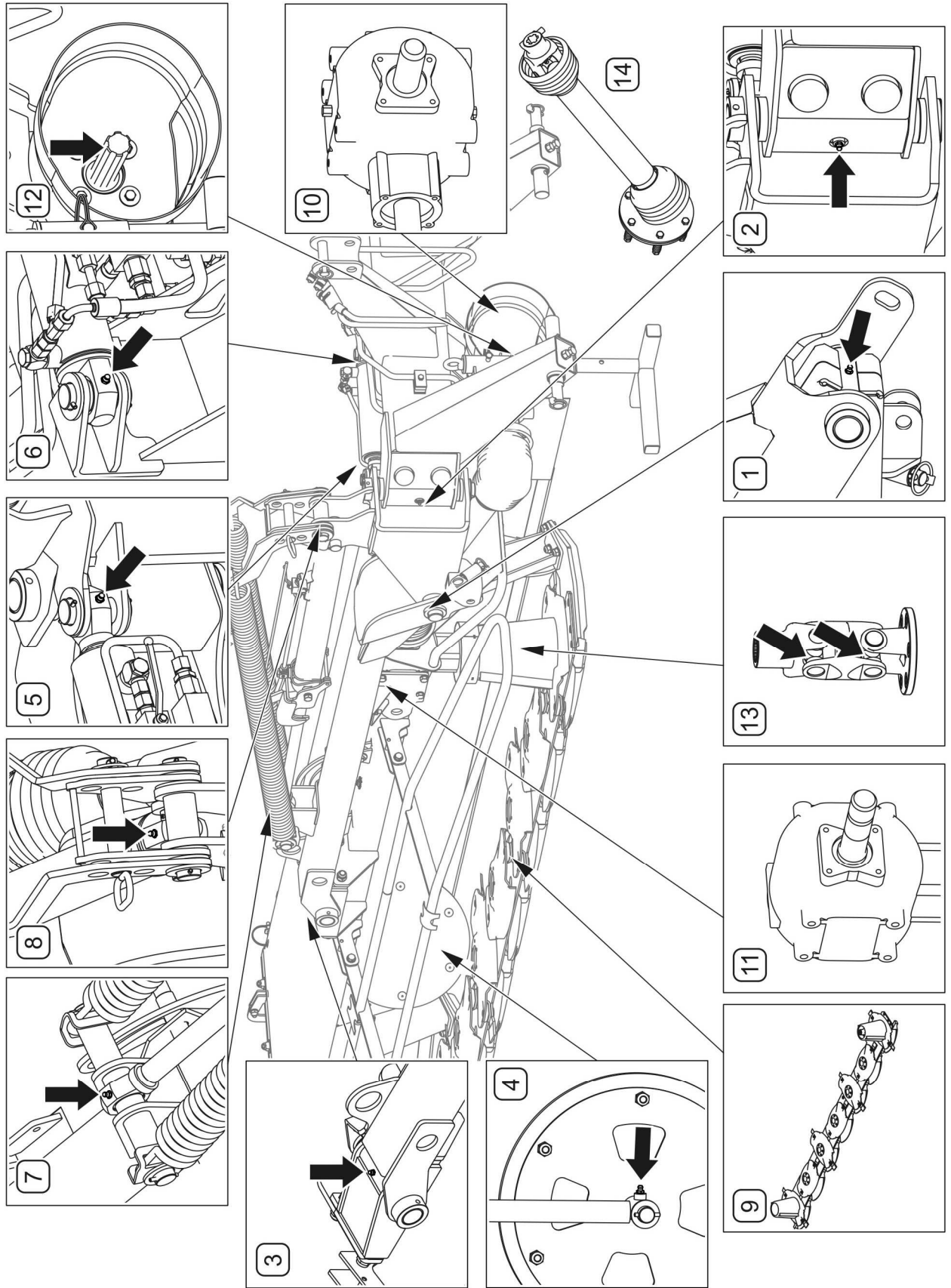

FIG. 5.5A Lubrication points

TAB. 5.3 LUBRICATION POINTS AND LUBRICATION FREQUENCY

ITEM	NAME	NUMBER OF LUBRICATION POINTS	TYPE OF GREASE	LUBRICATION FREQUENCY
1	Lifting pin of lifting arm	1	permanent grease	20 hours
2	Tipping pin of lifting arm	1	permanent grease	20 hours
3	Cutting unit pin	1	permanent grease	20 hours
4	Left and right swath guide disk axis	2	permanent grease	20 hours
5	Tilting arm cylinder ram eye	1	permanent grease	50 hours
6	Tilting arm cylinder ram eye	1	permanent grease	50 hours
7	Lifting arm cylinder ram eye	1	permanent grease	50 hours
8	Lifting arm cylinder eye	1	permanent grease	50 hours
9	Cutterbar	1	oil	500 hours
10	Intersecting axis gear I	1	oil	500 hours
11	Intersecting axis gear II	1	oil	500 hours
12	Surface of multi-splined driveshaft	1	permanent grease	20 hours
13	Cutterbar double articulated connection joint	2	permanent grease	50 hours
14	PTO shafts *	*	*	*

Description of markings in Item column (TAB. 5.3) conforms with numbering shown (FIG. 5.5A)

** For detailed information on maintenance please refer to maintenance instructions attached to the shaft.*

5.7 TIGHTENING TORQUE FOR NUT AND BOLT CONNECTIONS

Unless other tightening parameters are given, during maintenance repair work apply appropriate torque to tightening nut and bolt connections. Recommenders torque values apply to non-greased steel bolts.



ATTENTION!

Should it be necessary to change individual parts, use only original parts or those indicated by the manufacturer. Non-adherence to these requirements may put the user and other people's health and life at risk, and also damage the machine.

TAB. 5.4 TIGHTENING TORQUE FOR NUT AND BOLT CONNECTIONS

THREAD DIAMETER [mm]	5.8	8.8	10.9
	TIGHTENING TORQUE [Nm]		
M6	8	10	15
M8	18	25	36
M10	37	49	72
M12	64	85	125
M14	100	135	200
M16	160	210	310
M20	300	425	610
M24	530	730	1,050
M27	820	1,150	1,650
M30	1050	1 450	2 100
M32	1050	1,450	2,100

5.8 FAULTS AND MEANS OF REMEDYING THEM

TAB. 5.5 FAULTS AND MEANS OF REMEDYING THEM

TYPE OF FAULT	CAUSE	REMEDY
Mower arm does not lift or lower	Lifting arm interlocked	Remove interlocking pin
	Incorrect connection or damaged quick coupler	Check quick coupler and manner of connection
	Blocked cylinder lock	To unblock lock pull cable
	Unreliable tractor hydraulic system	Check condition of tractor hydraulic system
Stubble is uneven	Cutterbar is excessively load relieved	Set load relief stay appropriately
	Tractor PTO rotation speed too low	Maintain correct, constant PTO speed
	Worn cutting knives	Turn knives onto the second side or replace
	Incorrect cutting angle	Set appropriate cutterbar inclination by adjustment of top link
Excessive vibration during work	Damaged or missing knife	Check knives, if necessary replace
	Damaged PTO shaft	Check shafts, if necessary replace
	Damaged cutterbar bearing	Repair at authorised service point
Excessive heating of intersecting axis gear or cutterbar	Incorrect oil level	Check oil level.
	Damaged bearing	Repair at authorised service point
Hydraulic safety device does not work	Cylinder valve closed	Set cylinder interlock valve lever in open position
Mower drives stopping during cutting	Shaft overload clutch activated as a result of cutting discs being blocked	Disconnect power from mower; remove collected grass or foreign body from cutting unit
	Damaged cog in cutterbar	Repair at authorised service point
	Damaged intersecting axis gear	Repair at authorised service point

NOTES

A series of horizontal dotted lines for writing notes.

