



**PRONAR Sp. z o.o.**

17-210 NAREW, UL. MICKIEWICZA 101A, PODLASKIE PROVINCE

phone:	+48 085 681 63 29	+48 085 681 64 29
	+48 085 681 63 81	+48 085 681 63 82
fax:	+48 085 681 63 83	+48 085 682 71 10

*www.pronar.pl*

# **OPERATOR'S MANUAL**

## **MANURE SPREADER**

## **PRONAR N262**

## **PRONAR N262/1**

TRANSLATION OF THE ORIGINAL INSTRUCTIONS

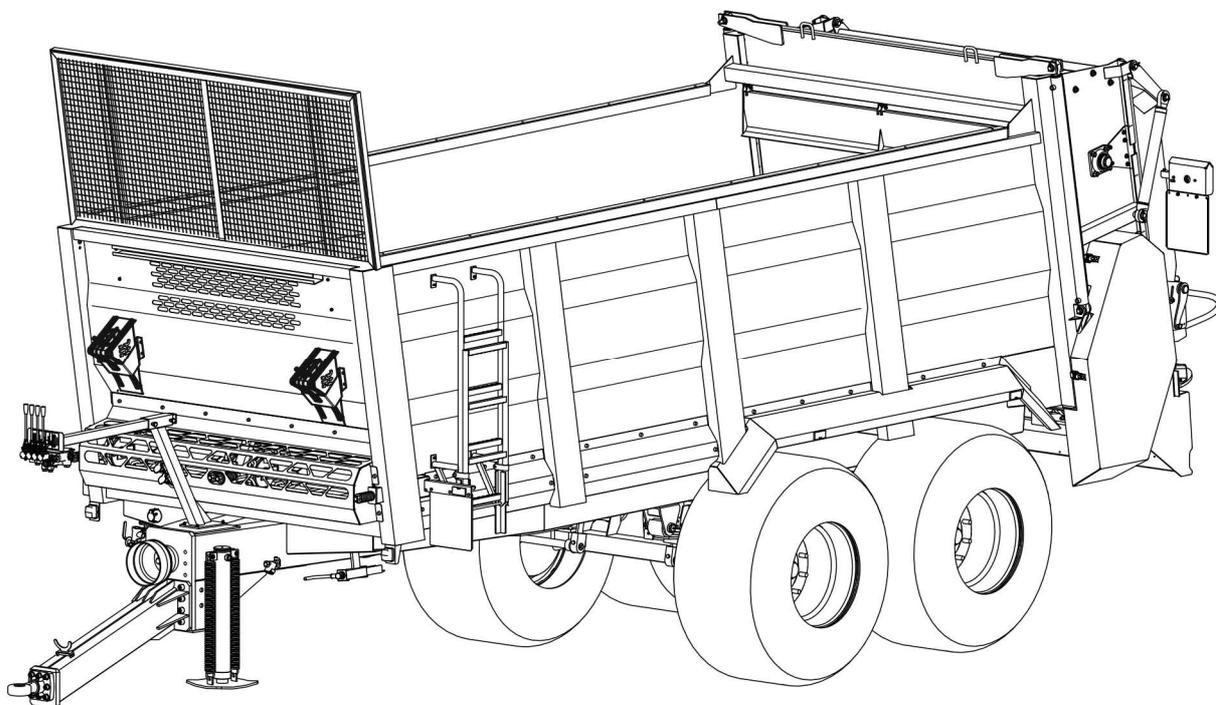

ISSUE 6B-07-2018

PUBLICATION NO 70N-0000000-UM





# INTRODUCTION

Information contained herein is current at date of publication. As a result of improvements, some numerical values and illustrations contained in this publication may not correspond to the factual specification of the machine supplied to the user. The manufacturer reserves the right to introduce design changes in machines produced that facilitate operation and improve the quality of their work, without making minor amendments to this Operator's Manual.

This Operator's Manual is an integral part of the machine's documentation. Before using the machine, the user must carefully read this Operator's Manual and observe all recommendations. This guarantees safe operation and ensures malfunction free work of the machine. The machine is designed to meet obligatory standards, documents and legal regulations currently in force.

The manual describes the basic safety rules and operation of Manure Spreader. If the information stated in the Operator's Manual needs clarification then the user should refer for assistance to the sale point where the machine was purchased or to the Manufacturer.

## MANUFACTURER'S ADDRESS:

*PRONAR Sp. z o.o.  
ul. Mickiewicza 101A  
17-210 Narew*

## CONTACT TELEPHONES

<i>+48 085 681 63 29</i>	<i>+48 085 681 64 29</i>
<i>+48 085 681 63 81</i>	<i>+48 085 681 63 82</i>

## SYMBOLS APPEARING IN THIS OPERATOR'S MANUAL

Information, descriptions of danger and precautions and also recommendations and prohibitions associated with user safety instructions are marked:



and also preceded by the word "**DANGER**". Failure to observe the instructions may endanger the machine operator's or other person's health or life.

Particularly important information and instructions, the observance of which is essential, are distinguished in the text by the sign:



and also preceded by the word "**ATTENTION**". Failure to observe the instructions may lead to damage to the machine as a result of improper operation, adjustment or use.

In order to focus the user's attention on the need to perform maintenance, the relevant section of the Operator's Manual is marked with the pictogram:



Additional tips and advice for machine operation are marked:



and also preceded by the word "**TIP**".

## **DIRECTIONS USED IN THIS OPERATOR'S MANUAL**

Left side – side to the left hand of the operator facing in the direction of machine's forward travel.

Right side – side to the right hand of the operator facing in the direction of machine's forward travel.

## **REQUIRED SERVICE ACTIONS**

Service actions described in the manual are marked: ➡

Result of service/adjustment actions or comments concerning the performance of actions are marked: ⇨



**PRONAR Sp. z o.o.**

ul. Mickiewicza 101 A  
17-210 Narew, Polska

tel./fax (+48 85) 681 63 29, 681 63 81, 681 63 82,  
681 63 84, 681 64 29

fax (+48 85) 681 63 83

http://www.pronar.pl

e-mail: pronar@pronar.pl

## EC DECLARATION OF CONFORMITY OF THE MACHINERY

PRONAR Sp. z o.o. declares with full responsibility, that the machine:

Description and identification of the machinery	
Generic denomination and function:	<b>Manure spreader</b>
Type:	<b>PS-R</b>
Model:	<b>N262</b> <b>N262/1</b>
Serial number:	
Commercial name:	<b>Manure spreader PRONAR N262</b> <b>Manure spreader PRONAR N262/1</b>

to which this declaration relates, fulfills all the relevant provisions of the Directive **2006/42/EC** of The European Parliament and of The Council of 17 May 2006 on machinery, and amending Directive 95/16/EC (Official Journal of the EU, L 157/24 of 09.06.2006).

The person authorized to compile the technical file is the Head of Research and Development Department at PRONAR Sp. z o.o., 17-210 Narew, ul. Mickiewicza 101A, Poland.

This declaration relates exclusively to the machinery in the state in which it was placed on the market, and excludes components which are added and/or operations carried out subsequently by the final user.

Narew, the 2018-05-24

*Place and date*

**„PRONAR”**  
Spółka z o.o.  
17-210 Narew, ul. Mickiewicza 101 A  
tel. (085) 681 6329 681 6429  
fax (085) 681 6383

Z-CIA DYREKTORA  
d/s technicznych  
czynności zarządcy

*Roman Stefaniniuk*

*Full name of the empowered person  
position, signature*

# CONTENTS

<b>1 BASIC INFORMATION</b>	<b>1.1</b>
1.1 IDENTIFICATION	1.2
1.1.1 AXLE IDENTIFICATION	1.4
1.1.2 LIST OF FACTORY NUMBERS	1.4
1.2 PROPER USE	1.5
1.3 EQUIPMENT	1.8
1.4 TERMS & CONDITIONS OF WARRANTY	1.9
1.5 TRANSPORT	1.10
1.5.1 TRANSPORT ON VEHICLE	1.11
1.5.2 INDEPENDENT TRANSPORT BY THE USER	1.12
1.6 ENVIRONMENTAL HAZARDS	1.13
1.7 WITHDRAWAL FROM USE	1.14
<b>2 SAFETY ADVICE</b>	<b>2.1</b>
2.1 BASIC SAFETY RULES	2.2
2.1.1 USE OF MACHINE	2.2
2.1.2 HITCHING AND DISCONNECTING FROM TRACTOR	2.3
2.1.3 HYDRAULIC AND PNEUMATIC SYSTEM	2.4
2.1.4 OPERATION WITH PTO	2.5
2.1.5 TRANSPORTING THE MACHINE	2.6
2.1.6 TYRES	2.7
2.1.7 MAINTENANCE	2.8
2.2 DESCRIPTION OF RESIDUAL RISK	2.9
2.3 INFORMATION AND WARNING DECALS	2.10
<b>3 DESIGN AND OPERATION</b>	<b>3.1</b>
3.1 TECHNICAL SPECIFICATION	3.2

3.2	MANURE SPREADER DESIGN	3.4
3.2.1	MANURE SPREADER BODY	3.4
3.2.2	FEEDING MECHANISM	3.6
3.2.3	HYDRAULIC SYSTEM OF FEEDING MECHANISM (SYSTEM CONTROLLED FROM THE TRACTOR)	3.7
3.2.4	HYDRAULIC SYSTEM OF STRAIGHT SUPPORT (SYSTEM CONTROLLED FROM THE TRACTOR)	3.9
3.2.5	HYDRAULIC SYSTEM OF TAILGATE (SYSTEM CONTROLLED FROM THE TRACTOR)	3.10
3.2.6	HYDRAULIC SYSTEM OF SLIDE GATE (SYSTEM CONTROLLED FROM THE TRACTOR)	3.11
3.2.7	HYDRAULIC SYSTEM (CONTROLLED FROM THE MANURE SPREADER)	3.13
3.2.8	SPREADER UNIT	3.15
3.2.9	DRIVE TRANSMISSION	3.16
3.2.10	MAIN BRAKE	3.18
3.2.11	PARKING BRAKE	3.22
3.2.12	LIGHTING SYSTEM, WARNING ELEMENTS	3.23

## **4 CORRECT USE 4.1**

4.1	PREPARING FOR WORK BEFORE FIRST USE	4.2
4.1.1	CHECKING THE MANURE SPREADER AFTER DELIVERY	4.2
4.1.2	PREPARING THE MANURE SPREADER FOR THE FIRST HITCH	4.3
4.1.3	TEST START	4.6
4.2	TECHNICAL CONDITION INSPECTION	4.8
4.3	HITCHING TO TRACTOR	4.9
4.4	LOADING THE LOAD BOX	4.12
4.5	SPREADING AND ADJUSTING FERTILIZER DOSE	4.13
4.5.1	ADJUSTING FERTILIZER DOSE	4.13
4.5.2	ADJUSTMENT OF SPREADING WIDTH	4.16
4.5.3	SPREADING MANURE IN THE FIELD	4.18

4.6	SPREADING MECHANISM CLOGGING	4.19
4.7	UNHITCHING FROM TRACTOR	4.20
4.8	PROPER USE AND MAINTENANCE OF TYRES	4.21

## **5 MAINTENANCE** **5.1**

5.1	PRELIMINARY INFORMATION	5.2
5.2	SERVICING BRAKES AND AXLES	5.2
5.2.1	PRELIMINARY INFORMATION	5.2
5.2.2	INITIAL INSPECTION OF AXLE BRAKES	5.3
5.2.3	CHECK BRAKE SHOE LININGS FOR WEAR	5.4
5.2.4	CHECK WHEEL AXLE BEARINGS FOR LOOSENESS	5.5
5.2.5	ADJUSTMENT OF PLAY OF WHEEL AXLE BEARINGS	5.7
5.2.6	MOUNTING AND DISMOUNTING WHEEL, INSPECTION OF WHEEL NUT TIGHTENING	5.8
5.2.7	CHECK AIR PRESSURE, EVALUATE TECHNICAL CONDITION OF WHEELS AND TYRES	5.11
5.2.8	MECHANICAL BRAKES ADJUSTMENT	5.12
5.2.9	CHANGE OF PARKING BRAKE CABLE AND ADJUSTMENT OF CABLE TENSION	5.13
5.3	PNEUMATIC SYSTEM MAINTENANCE	5.16
5.3.1	PRELIMINARY INFORMATION	5.16
5.3.2	INSPECTING AND CHECKING AIR TIGHTNESS OF PNEUMATIC SYSTEM.	5.17
5.3.3	CLEANING THE AIR FILTERS	5.18
5.3.4	DRAINING WATER FROM AIR TANK	5.20
5.3.5	CLEAN DRAIN VALVE	5.21
5.3.6	CLEANING AND MAINTAINING PNEUMATIC LINE CONNECTIONS AND PNEUMATIC SOCKETS	5.21
5.3.7	REPLACEMENT OF THE PNEUMATIC LINE	5.22
5.4	HYDRAULIC SYSTEM OPERATION	5.23
5.5	REDUCTION GEAR MAINTENANCE	5.25

5.6	MANURE SPREADER LUBRICATION	5.26
5.7	CLIMBING INTO THE LOAD BOX	5.31
5.8	CLEANING	5.32
5.9	PREPARATION FOR END OF SEASON	5.34
5.10	PREPARATION FOR THE BEGINNING OF A NEW FIELDWORK SEASON	5.35
5.11	STORAGE	5.36
5.12	REPLACEMENT OF THE SPREADING MECHANISM BLADES	5.36
5.13	CHECKING AND REPLACEMENT OF SPREADER UNIT KNIVES	5.38
5.14	CHECKING AND ADJUSTMENT OF TENSION OF FLOOR CONVEYOR CHAIN	5.39
5.15	OPERATION OF ELECTRICAL SYSTEM AND WARNING ELEMENTS	5.41
	5.15.1 PRELIMINARY INFORMATION	5.41
	5.15.2 CHANGING BULBS	5.42
5.16	ADJUSTMENT OF THE UPPER DRAWBAR EYE POSITION	5.42
5.17	MAINTENANCE OF CHAIN TRANSMISSIONS	5.44
5.18	TIGHTENING TORQUE FOR NUT AND BOLT CONNECTIONS	5.45
5.19	TROUBLESHOOTING	5.47

*SECTION*

**1**

---

**BASIC  
INFORMATION**

# 1.1 IDENTIFICATION

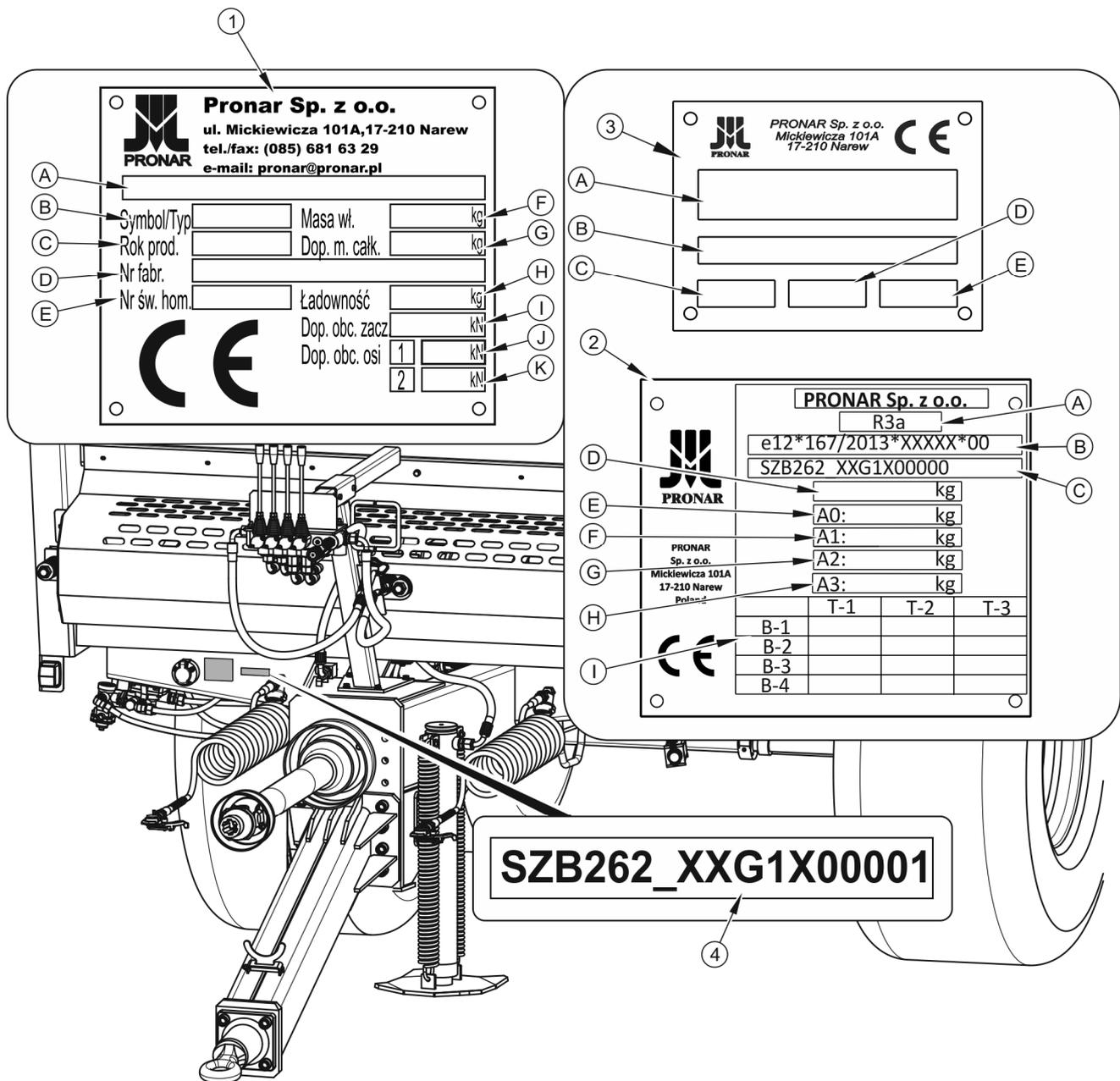

**FIG. 1.1 Manure spreader identification**

(1) data plate – version standard, (2) data plate – version EU, (3) data plate CE– version EU, (4) serial number

The manure spreader is marked with the data plate (1) – version standard, or (2) and (3) - version EU and the factory number (4) located on a gold painted rectangle. The serial number and data plate are located on the right angle brace of the lower frame, figure (1.1).

When buying the manure spreader check that the factory numbers on the machine agree with the number written in the *WARRANTY BOOK*, in the sales documents and in the *OPERATOR'S MANUAL*. The meanings of the individual fields found on the data plate are presented in the table (1.1), (1.2), (1.3).

**TAB. 1.1 Markings on data plate - version standard**

ITEM	MARKING
A	General description and purpose
B	Symbol /Type
C	Year of manufacture
D	Seventeen digit serial number (VIN)
E	Official certificate number
F	Machine tare weight
G	Maximum gross weight
H	Carrying capacity
I	Permissible hitching system loading
J	Permissible front axle load
K	Permissible rear axle load

**TAB. 1.2 Markings on data plate - version EU**

ITEM	MARKING
A	Vehicle category according to R167/2013
B	Official certificate number
C	Seventeen digit serial number (VIN)
D	Maximum gross weight
E	Permissible hitching system loading
F	Permissible load – axle 1
G	Permissible load – axle 2
H	Permissible load – axle 3
I	Technically permissible towable mass for each chassis/braking configuration for R or S category Vehicle

**TAB. 1.3 Markings on data plate CE - version EU**

ITEM	MARKING
A	General description and purpose
B	Seventeen digit serial number (VIN)
C	Type
D	Year of manufacture
E	Model

**1.1.1 AXLE IDENTIFICATION**

The factory number of the axle shaft and its type are stamped onto the data plate (2) secured to the axle shaft beam (1) – figure (1.2).

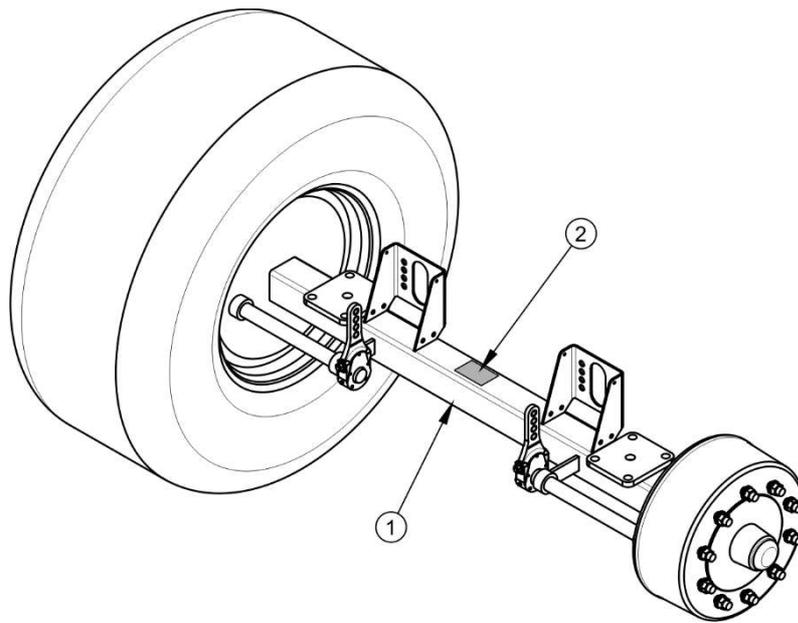

**FIG. 1.2 Location of the axle data plate**

*(1) wheel axle, (2) data plate*

**1.1.2 LIST OF FACTORY NUMBERS**

	<p><b>TIP</b></p>
<p>In the event of ordering a replacement part or in the case of the appearance of problems it is often essential to give the factory numbers of parts or the VIN number of the manure spreader, therefore it is recommended that these numbers are inscribed in the spaces below.</p>	

**VIN**

S	Z	B	2	6	2	0	X	X			X					
---	---	---	---	---	---	---	---	---	--	--	---	--	--	--	--	--

**FRONT AXLE FACTORY NUMBER AND TYPE**

**REAR AXLE FACTORY NUMBER AND TYPE**

## 1.2 PROPER USE

Pronar manure spreader is designed for uniform spreading of all kinds of manure, lime, peat and compost. The special municipal version of the manure spreader with the sealed load box is designed for spreading dehydrated sludge. The manure spreader must not be used in any way other than that described above. Using it as intended also involves all actions connected with the safe and proper operation and maintenance. The manure spreader is not intended or designed for transporting people or animals.

The manure spreader is constructed according to current safety requirements and engineering standards. The brake system and the light and indicator system meet the requirements of road traffic regulations. The maximum speed of the manure spreader on public roads is 30 km/h in Poland (pursuant to Traffic Law Act of June 20th 1997, article 20). In the countries where the manure spreader is used, the limits stipulated by the road traffic legislation in force in a given country must be observed. The manure spreader speed must not, however, be greater than the maximum design speed.

### ATTENTION

The manure spreader must not be used for purposes other than those for which it is intended, in particular:



- transport people, animals, hazardous materials, chemically aggressive loads that will corrode the construction elements of the spreader
- for spreading and transporting toxic and flammable materials,
- for spreading fluids, sand or fibrous substances,

- for transporting construction materials, single objects or any materials and substances outside the scope of intended use of the manure spreader,
- overload the spreader in excess of its load carrying capacity.

Using it as intended also involves all actions connected with the safe and proper operation and maintenance of the machine. In connection with this the user is obliged to:

- carefully read the *OPERATOR'S MANUAL* of the manure spreader and the *WARRANTY BOOK* and conform with the recommendations contained in these documents,
- understand the manure spreader's operating principle and how to operate it safely and correctly,
- adhere to the established maintenance and adjustment plans,
- comply with general safety regulations while working,
- prevent accidents,
- comply with the road traffic regulations and transport regulations in force in a given country, in which the manure spreader is used,
- carefully read the Operator's Manual and comply with its recommendations,
- only hitch the manure spreader to an agricultural tractor, which fulfils all the requirements made by the rotary rake's Manufacturer.

The manure spreader may only be used by persons, who:

- are familiar with the contents of this publication and with the contents of the agricultural tractor Operator's Manual,
- have been trained in manure spreader operation and safe operation,
- have the required authorisation to drive and are familiar with the road traffic regulations and transport regulations.

**TAB. 1.4 Agricultural tractor's requirements**

CONTENTS	UNIT	REQUIREMENTS
<b>Brake system - sockets</b>		
Single line pneumatic system	-	according to PN-ISO 1728
or		
Double line pneumatic system	-	according to PN-ISO 1728
<b>Nominal pressure of the pneumatic system</b>	bar / kPa	6.5 / 650
<b>Hydraulic system</b>		
Number of connections (controlled from the tractor)	-	4 pairs
Number of connections (controlled from the manure spreader)	-	2 pairs
Hydraulic oil:	-	L-HL32 Lotos <sup>(1)</sup>
Nominal pressure in the system	bar / MPa	160 / 16
Oil demand:	l	6.5
<b>Electrical system</b>		
Electrical system voltage	V	12
Connection socket	-	7 polar compliant with ISO 1724
<b>Other requirements</b>		
PTO speed	RPM	1 000
PTO rotation direction	-	Clockwise (looking at the shaft front)
Minimum power demand N262	kW / Horsepower	93.6 / 127.3
Minimum power demand N262/1	kW / Horsepower	109 / 148
Minimum vertical load capacity of hitch	kg	2 200

<sup>(1)</sup> – use of other oil is permitted, on condition that it may be mixed with the oil in the manure spreader.

Detailed information may be found on the product information card.

## 1.3 EQUIPMENT

**TAB. 1.5 Manure spreader equipment**

EQUIPMENT	STANDARD	ADDITIONAL	OPTIONS
Operator's Manual	•		
Warranty book	•		
Connection lead for the electrical system	•		
Wheel chocks	•		
PTO shaft for connecting the manure spreader with the tractor (selected according to the profile of the tractor's PTO shaft)		•	
Slide gate	•		
Mechanism indicating that the slide gate is raised	•		
Tailgate with rubber shield	•		
Rear beam		•	
Rotating drawbar eye Ø50			•
Ball drawbar eye K80.			•
Fixed drawbar eye Ø40			•
Slow-moving vehicle warning sign		•	
Warning reflective triangle		•	
Upper drawbar			•
Hydraulic brake system			•
Double line pneumatic system with ALB.			•
Hydraulic system controlled by the tractor's hydraulic manifold	•		
Hydraulic system controlled by the manure spreader's hydraulic manifold			•

Information concerning tires is provided at the end of this publication in *ANNEX A*.

**Recommended PTO shafts for connecting spreader with tractor:**

- - manufacturer: Bondioli & Pavesi, type 7 106 101 CE 007 007, (6/6) <sup>(1)</sup>,
- - manufacturer: Bondioli & Pavesi, type 7 1R6 091 CE WR7 007, (6/6) (wide-angle shaft) <sup>(1)</sup>,
- - manufacturer: Bondioli & Pavesi, type 7 106 101 CE 008 007, (21/6) <sup>(2)</sup>,
- - manufacturer: Bondioli & Pavesi, type 7 1R6 091 CE WR8 007, (21/6) (wide-angle shaft) <sup>(2)</sup>,
- manufacturer: Bondioli & Pavesi, type 7 106 101 CE R10 007, (20/6) <sup>(3)</sup>,
- manufacturer: Bondioli & Pavesi, type 7 1R6 091 CE WR0 007, (20/6) (wide-angle shaft) <sup>(3)</sup>.

<sup>(1)</sup> 6-spline end of PTO shaft on the tractor side.

<sup>(2)</sup> 21-spline end of PTO shaft on the tractor side.

<sup>(3)</sup> 20-spline end of PTO shaft on the tractor side.

## 1.4 TERMS & CONDITIONS OF WARRANTY

PRONAR Sp. z o.o. Narew guarantees the reliable operation of the machine when it is used according to its intended purpose as described in the *OPERATOR'S MANUAL*. The repair period is specified in the *WARRANTY BOOK*.

The warranty does not apply to those parts and sub-assemblies of the machine, which are subject to wear in normal usage conditions, regardless of the warranty period. Consumables include the following parts/sub-assemblies:

- drawbar hitching eye,
- pneumatic system connector filters,
- tyres,
- brake shoes,
- bulbs,
- seals,
- chains,
- disintegrating knives,

- blades of wide spread mechanism,
- gear wheels,
- bearings.

The warranty service only applies to factory defects and mechanical damage that is not due to the user's fault.

In the event of damage arising from:

- mechanical damage which is the user's fault, caused by road accidents,
- by inappropriate use, adjustment or maintenance, use of the slurry tanker for purposes other than those for which it is intended,
- use of damaged machine,
- repairs carried out by unauthorised persons, improperly carried out repairs,
- making unauthorised alterations to machine design,

the user will lose the right to warranty service.



### TIP

**Demand that the seller carefully and precisely fills out the Warranty Book and warranty repair coupons. A missing date of purchase or sale point stamp, may make the user ineligible for any warranty repair or refund.**

The user is obliged to report immediately on noticing any wear in the paint coating or traces of corrosion, and to have the faults rectified whether they are covered by the warranty or not. For detailed Terms & Conditions of Warranty, please refer to the *WARRANTY BOOK* attached to each machine.

Modification of the manure spreader without the written consent of the Manufacturer is forbidden. In particular, do NOT weld, drill holes in, cut or heat the main structural elements of the machine, which have a direct impact on the machine operation safety.

## 1.5 TRANSPORT

The manure spreader is ready for sale completely assembled and does not require packing. Packing is only required for the machine's technical documentation and any extra fittings. The manure spreader is delivered to the user either transported on a vehicle or, independently (towed), after being attached to a tractor.

### 1.5.1 TRANSPORT ON VEHICLE

Loading and unloading of the manure spreader from vehicle shall be conducted using loading ramp with the aid of an agricultural tractor. During work adhere to the general principles of Health and Safety at Work applicable to reloading work. Persons operating reloading equipment must have the qualifications required to operate these machines. The manure spreader must be properly connected with the tractor according to the requirements closed in this Operators Manual. The brake system must be started in checked before driving off or onto ramp.

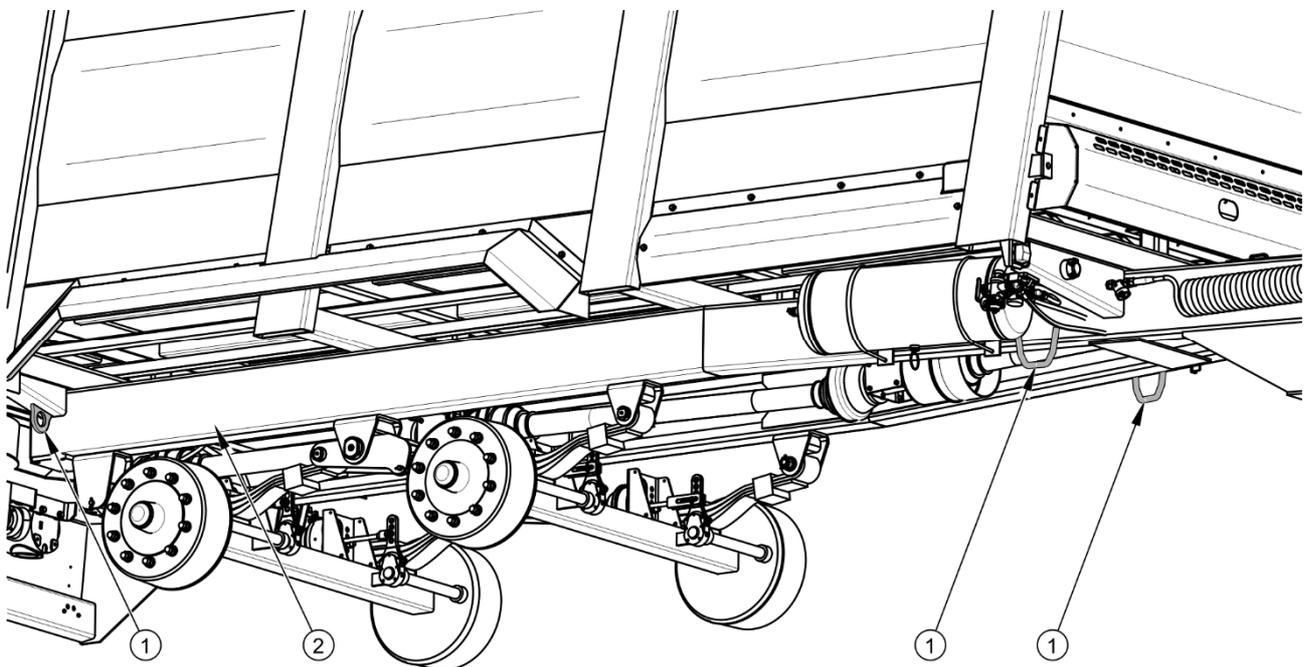

**FIG. 1.3**      **Positioning of transport lugs**

*(1) transport lug, (2) lower longitudinal frame*

The manure spreader should be attached firmly to the platform of the vehicle using straps or chains fitted with a tightening mechanism. Securing elements should be attached to the transport catches designed for this purpose (1) – figure (1.3), permanent structural elements of the spreader (longitudinal and transverse frame sections etc.). Transport catches (hooks and eyes) are welded to lower longitudinal frame (2), with one pair on each side. Use certified and technically reliable securing measures. Worn straps, cracked securing catches, bent or corroded hooks as well as other damage may disqualify use of the given element from use. Carefully read the information stated in the Operator's Manual for the given securing measure. Chocks, wooden blocks or other objects without sharp edges should be placed

under the wheels of the manure spreader to prevent it from rolling. Manure spreader wheel blocks must be nailed to the low platform planks of the vehicle or secured in another manner preventing their movement. The number of securing elements (cables, straps, chains and stays etc.) and the force necessary for their tensioning depends on a number of things, including weight of the manure spreader, the construction of vehicle carrying manure spreader, speed of travel and other conditions. For this reason it is impossible to define the securing plan precisely. A correctly secured manure spreader does not change its position with regard to the transport in vehicle. The securing elements must be selected according to the guidelines of the Manufacturer of these elements. In case of doubt apply a greater number of securing straps in order to immobilise the machine. If necessary, sharp edges of the manure spreader should be protected at the same time protecting the securing straps from breaking during transport.

### **IMPORTANT**



**When being road transported on a motor vehicle the manure spreader must be mounted on the vehicle's platform in accordance with the transport safety requirements and the regulations.**

**Driver of the vehicle should be particularly careful during travel. This is due to the vehicle's centre of gravity shifting upwards when loaded with the machine.**

**Use only certified and technically reliable securing measures. Carefully read the manufacturer's instructions for the securing measures.**

During reloading work, particular care should be taken not to damage parts of the machine's fittings or the lacquer coating. The tare weight of the manure spreader in condition ready for travel is given in table (3.1).



### **DANGER**

**Incorrect application of securing measures may cause an accident.**

## **1.5.2 INDEPENDENT TRANSPORT BY THE USER**

In the event of independent transport by the user after purchase of the manure spreader, the user must read the manure spreader Operator's Manual and adhere to the recommendations contained therein. Independent transport involves towing the manure spreader with own

agricultural tractor to destination. During transport adjust travel speed to the prevailing road conditions, but do not exceed the maximum design speed.



### **IMPORTANT**

**Before transporting independently, the tractor driver must carefully read this operator's manual and observe its recommendations.**

## **1.6 ENVIRONMENTAL HAZARDS**

A hydraulic oil leak constitutes a direct threat to the natural environment owing to its limited biodegradability. Because of the low solubility of oil in water, it is not highly toxic to living organisms. An oil leak into water reservoirs may however lead to a reduction of the oxygen content. While carrying out maintenance and repair work, which involves the risk of an oil leak, this work should take place on an oil resistant floor or surface. In the event of oil leaking into the environment, first of all contain the source of the leak, and then collect the leaked oil using available means. Remaining oil should be collected using sorbents, or by mixing the oil with sand, sawdust or other absorbent materials. The oil pollution, once gathered up, should be kept in a sealed, marked, hydrocarbon resistant container. The container should be kept away from heat sources, flammable materials and food.



### **DANGER**

**Used hydraulic oil or gathered remains mixed with absorbent material should be stored in a precisely marked container. Do not use food packaging for this purpose.**

Oil, which has been used up or is unsuitable for further use owing to a loss of its properties should be stored in its original packaging in the conditions described above. Waste oil should be taken to the appropriate facility dealing with the re-use of this type of waste. Waste code: 13 01 10. Detailed information concerning hydraulic oil may be found on the product's Material Safety Data Sheet.



### **TIP**

**The hydraulic system of the manure spreader is filled with L-HL32 Lotos hydraulic oil.**

**IMPORTANT**

Waste oil should only be taken to the appropriate facility dealing with the re-use of this type of waste. Do NOT throw or pour oil into sewerage or water tanks.

## 1.7 WITHDRAWAL FROM USE

In the event of decision by the user to withdraw the machine from use, comply with the regulations in force in the given country concerning withdrawal from use and recycling of machines withdrawn from use. Before commencing dismantling, totally remove the oil from the hydraulic system and reduce air pressure completely in the pneumatic brake system (e.g. using air tank drain valve).

**DANGER**

During dismantling, use the appropriate tools, equipment (overhead travelling crane, crane or hoist etc.) and use personal protection equipment, i.e. protective clothing, footwear, gloves and eye protection etc.

Avoid contact of skin with oil. Do not allow used hydraulic oil to spill.

When spare parts are changed, worn out or damaged parts that cannot be reclaimed should be taken to a collection point for recyclable raw materials. Hydraulic oil should be taken to the appropriate facility dealing with the re-use of this type of waste.

**SECTION**

**2**

---

**SAFETY ADVICE**

## 2.1 BASIC SAFETY RULES

### 2.1.1 USE OF MACHINE

- Before using the machine, the user must carefully read this Operator's Manual and the Operator's Manual of the PTO shaft. During use all the recommendations laid down in this Operator's Manual should be observed.
- If the information stated in the Operator's Manual is difficult to understand, contact a seller, who runs an authorised technical service on behalf of the Manufacturer, or contact the Manufacturer directly.
- The machine must never be used by persons, who are not authorised to drive agricultural tractors, including children and people under the influence of alcohol or other drugs.
- Careless and improper use and operation of the manure spreader, and non-compliance with the recommendations given in this operator's Manual is dangerous to your health.
- Non-compliance with the safety rules of this Operator's Manual can be dangerous to the health and life of the operator and others.
- Be aware of the existence of a residual risk, and for this reason the fundamental basis for using this machine should be the application of safety rules and sensible behaviour.
- The machine must not be used for purposes other than those for which it is intended. Anyone who uses the machine other than the way intended takes full responsibility for himself for any consequences of this use.
- Any modification to the manure spreader frees the manufacturer from any responsibility for damage or detriment to health which may arise as a result.
- Before activating the manure spreader, always ensure that all the safety guards are in good condition and in place. Damaged or incomplete sub-assemblies must be exchanged for original new ones.

- Before each use of the manure spreader check its technical condition. In particular, check the technical condition of the hitch system, the axle system, brake systems and indicator lights and tension of feeding chain.
- The machine can only be stood on when it is absolutely motionless and the tractor engine is switched off.
- Staying in the material spreading area is forbidden due to danger which may be caused by stones, pieces of wood etc. contained in the material.
- Take particular care while spreading material near roads and other vehicles.
- Take particular care while spreading material near people and animals.
- Do not carry people or animals on the manure spreader.

### **2.1.2 HITCHING AND DISCONNECTING FROM TRACTOR**

- Prior to attaching the manure spreader to tractor, check the technical condition of the manure spreader's and tractor's hitch system, drive shaft and connection elements of the hydraulic, electrical and pneumatic systems.
- The spreader and tractor must not be attached if the hydraulic oil in the two machines is of different types.
- When connecting the hydraulic lines to the tractor, make sure that the hydraulic system of the tractor and manure spreader is not under pressure.
- The manure spreader may only be used when all the safety guards and other protective elements are technically sound and correctly positioned.
- While connecting the spreader to the tractor, use the appropriate tractor hitch.
- Be especially careful when hitching the machine to the tractor or truck tractor.
- When hitching, there must be nobody between the manure spreader and the tractor.
- Regularly check the condition of connections and safety devices.
- The manure spreader disconnected from the tractor must be immobilised with the parking brake.
- If the machine is positioned on a slope or elevation it should be additionally secured against moving by placing chocks under the machine's wheels.

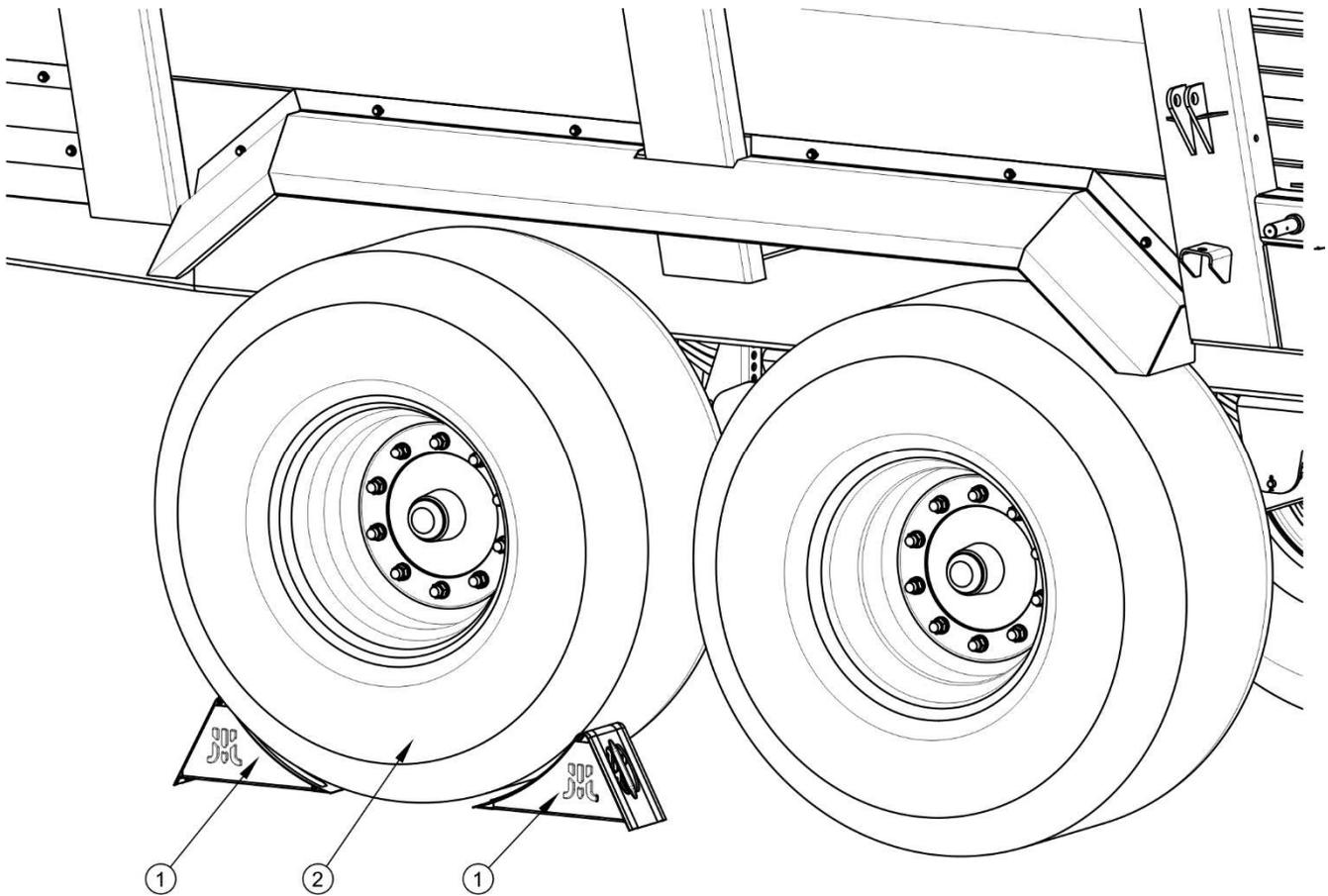

**FIG. 2.1** Method of placing chocks

(1) wheel chock, (2) axle wheel

- Chocks (1), should be placed only under one wheel (one in front of the wheel, the second behind the wheel - figure (2.1)).

### 2.1.3 HYDRAULIC AND PNEUMATIC SYSTEM

- When operating, the hydraulic and pneumatic systems are under high pressure.
- Use the hydraulic oil recommended by the Manufacturer. Never mix two types of oil.
- Regularly check the technical condition of the connections and the hydraulic and pneumatic leads.
- In the event of malfunction of the hydraulic or pneumatic system, do not use the machine until the malfunction is corrected.
- Check condition of machine hydraulic system frequently, oil leaks are not allowed.

- Before beginning repair works on hydraulic or pneumatic systems reduce oil or air pressure.
- In the event of injuries being caused by pressurised hydraulic oil, contact a doctor immediately. Hydraulic oil may find its way under the skin and cause infections.
- After changing the hydraulic oil, the used oil should be properly disposed of.

#### **2.1.4 OPERATION WITH PTO**

- Before using the machine the user should thoroughly acquaint himself with the PTO shaft Operator's Manual and adhere to the recommendations contained in it.
- The manure spreader may only be connected to the tractor by appropriately selected PTO shaft recommended by the Manufacturer.
- The drive shaft must be equipped with a cover. Do NOT use the shaft with damaged or missing guards.
- After connecting shaft ensure that it is correctly and safely connected to the tractor and to the manure spreader.
- Do NOT wear loose clothing, straps or whatever that may become wrapped round the rotating drive shaft. Contact with rotating PTO shaft may cause severe injuries.
- Before disconnecting the shaft, turn off the tractor engine and remove the key from the ignition.
- When working in limited visibility conditions, use the tractor's working lights to illuminate the PTO shaft and its vicinity.
- During transport the shaft must be stored in the horizontal position to avoid damage to safety guards or other protection elements.
- When using the manure spreader and power take-off shaft, do not use PTO rotation speed other than 1000 rpm. Do NOT overload shaft and manure spreader and also engage the clutch suddenly. Before starting PTO shaft make certain that the PTO rotation direction is correct.
- Do NOT go over and under the shaft or stand on it equally during work and also when the manure spreader is parked.

- The PTO shaft has markings on the casing, indicating, which end of the shaft shall be connected to the tractor.
- Never use a damaged PTO shaft, it may cause an accident. A damaged shaft must be repaired or replaced.
- Disconnect the drive shaft each time when it is not necessary to drive the machine, or when the tractor and spreader are at an unsuitable angle to each other.
- The chains preventing the shaft cover from turning while the shaft is working, shall be secured to a fixed element of spreader structure.
- Do NOT use the securing chains to support the shaft while machine is parked or when transporting the spreader.

### **2.1.5 TRANSPORTING THE MACHINE**

- When driving on public roads, comply with the road traffic regulations in force in the country, in which the spreader is used.
- Do not exceed the maximum design speed. Adjust driving speed to the road conditions.
- Travel speed must be adapted to environmental conditions and load. If possible avoid travelling on uneven terrain and unexpected corners.
- Exceeding the maximum load capacity of the spreader may damage it, and also threaten the safety of traffic.
- Load the manure spreader in such a manner as to ensure that the road is not soiled with transported material while driving on public roads.
- Place the slow-moving vehicle warning sign on the rear wall – figure (2.2). The warning sign (1) should be attached using the specifically prepared holder (2), riveted to the rear wall of the load box.

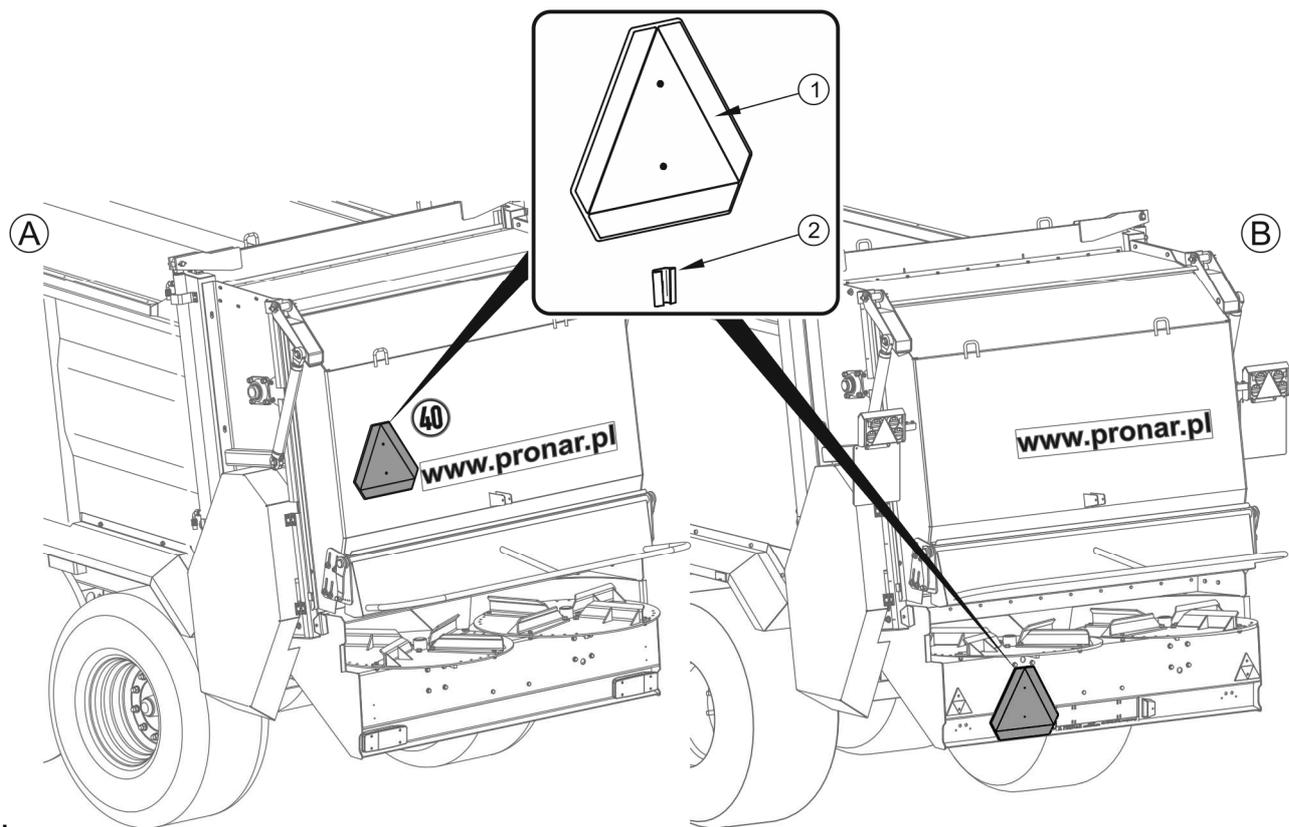

**FIG. 2.2 Positioning the warning sign**

(A) version standard, (B) version EU, (1) warning sign, (2) attachment point

- The machine must NOT be left unsecured. Securing the spreader involves engaging the parking brake and/or placing chocks or other objects without any sharp edges under spreader wheels.
- During reversing one should use the assistance of another person. During manoeuvring the person helping must stay at a safe distance from the danger zone and be visible all the time to the tractor driver.
- While driving on public roads the trailer must be fitted with a certified or authorised reflective warning triangle.

### 2.1.6 TYRES

- When working on the tyres, chocks attached to spreader should be placed under the wheels of the spreader to prevent it from rolling.
- Repair work on the wheels or tyres should be carried out by persons trained and entitled to do so. This work should be carried out using appropriate tools.

- Each time a wheel is fitted, always check how firmly the nuts are tightened. Individual checks should be made after the first use, after the first journey with a load, after travelling 1000 km and then every 6 months. The above actions should be repeated individually if a wheel has been removed from the wheel axle.
- Check the tyre pressure regularly.
- Protect tyre valves using suitable caps to avoid soiling.

### **2.1.7 MAINTENANCE**

- During the warranty period, any repairs may only be carried out by Warranty Service authorised by the manufacturer. After the expiry of the warranty period it is recommended that possible repairs be performed by specialised workshops.
- Servicing and repair work should be carried out in line with the general principles of workplace health and safety. In the event of injury, the wound must be immediately cleaned and disinfected. In the event of more serious injuries, seek a doctor's advice.
- Repair, maintenance and cleaning work should be carried out with the tractor engine turned off and the ignition key removed.
- Regularly check the condition of the bolt and nut connections.
- Before welding or electrical work, the manure spreader should be disconnected from the power supply.
- Should it be necessary to change individual parts, use only original parts. Non-adherence to these requirements may put the user and other people's health and life at risk, and also damage the manure spreader and invalidate the warranty.
- The paint coating should be cleaned off before beginning welding work. Burning paint fumes are poisonous for people and animals. Welding work should be carried out in a well lit and well ventilated space.
- During welding work pay attention to flammable or fusible elements (parts of the pneumatic, electric and hydraulic systems, plastic parts). If there is a risk that they will catch fire or be damaged, they should be removed before commencing welding work.
- In the event of work requiring the manure spreader to be raised, use properly certified hydraulic or mechanical lifts for this purpose. After lifting the manure spreader, stable

and durable supports must also be used. Do NOT carry out work under the manure spreader, which has only been raised with the lift jack.

- The spreader must not be supported using fragile elements (bricks or concrete blocks).
- During maintenance with the tailgate raised, protect it from falling down using a cut-off valve and a suitable mechanical support which is durable and stably mounted.
- After completing work associated with lubrication, remove excess oil or grease.
- Manure spreader, spreader unit in particular, should be kept clean.
- Remove the remains of manure from the manure spreader each time after finished work.
- Before climbing on to the manure spreader's load box, make sure unauthorised persons do not have access to the tractor, disconnect PTO shaft and disconnect hydraulic system lines from the tractor.
- Climbing into the manure spreader's load box is possible only using a ladder.
- While climbing on to the manure spreader's load box, the manure spreader must be absolutely motionless.
- Exercise caution when climbing on top of the spreader load box.

## **2.2 DESCRIPTION OF RESIDUAL RISK**

Pronar Sp. z o. o. in Narew has made every effort to eliminate the risk of accidents. There is, however, a certain residual risk, which could lead to an accident, and this is connected mainly with the actions described below:

- using manure spreader for purposes other than those described in the Operator's Manual,
- being between the tractor and the manure spreader while the engine is running and when the machine is being attached,
- operation of the manure spreader by persons under the influence of alcohol or other intoxicating substances,
- operation of manure spreader by an authorised person,

- being on the machine when it operates,
- cleaning, maintenance and technical checks of the spreader,
- using unreliable PTO shaft,
- occurrence of dead zones in the field of view.

The residual risk may be kept to a minimum by following the recommendations below:

- prudent and unhurried operation of the machine,
- sensible application of the remarks and recommendations contained in the *OPERATOR'S MANUAL*,
- maintaining safe distance from forbidden or dangerous places
- a ban on being on the machine when it is operating,
- carrying out repair and maintenance work by persons trained to do so,
- using suitable protective clothing,
- ensuring unauthorised persons have no access to the machine, especially children,
- making certain that there are no persons in the driver's blind spots (particularly while reversing).

## 2.3 INFORMATION AND WARNING DECALS

The manure spreader is marked with information and warning decals referred to in table (2.1). The symbols are positioned as presented in figures (2.3) and (2.4). Throughout the time it is in use, the user of the machine is obliged to take care that notices and warning and information symbols located on the manure spreader are clear and legible. In the event of their destruction, they must be replaced with new ones. Safety decals can be purchased from the Manufacturer of the manure spreader or your PRONAR dealer. New assemblies, changed during repair, must be labelled once again with the appropriate safety signs.

TAB. 2.1 Information and warning decals

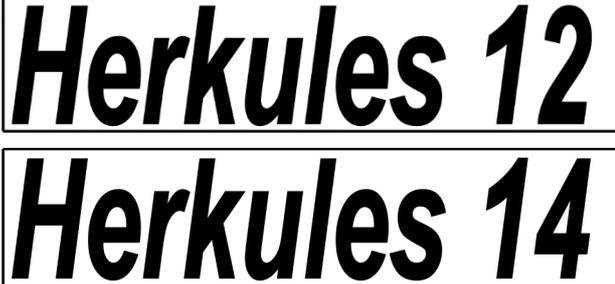
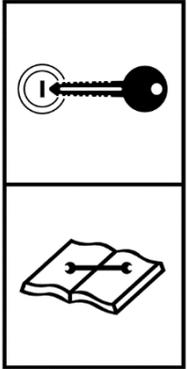
ITEM	SAFETY SYMBOL	DESCRIPTION
1		Machine Symbol
2		Machine name
3		Before starting work, carefully read the Operator's Manual.
4		Before beginning servicing or repairs, turn off engine and remove key from ignition

ITEM	SAFETY SYMBOL	DESCRIPTION
5		<p>Beware of thrown out objects.</p> <p>Thrown out objects endanger the whole body. Keep a safe distance from the spreader unit, minimum 25 metres</p>
6		<p>Danger of crushing.</p> <p>Do not stand near the opening tailgate of the spreader unit.</p>
7		<p>Caution!</p> <p>Do not stand on the chain conveyor if the tractor engine is running and PTO shaft is engaged</p>
8		<p>Caution! Danger of crushing</p> <p>Do not stand under the raised tailgate of the spreader unit</p>

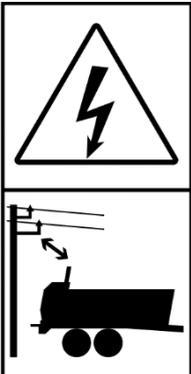
ITEM	SAFETY SYMBOL	DESCRIPTION
9		<p>Caution! Danger of crushing. Keep a safe distance from the rotating spreading discs</p>
10		<p>Caution! Danger of crushing. Do not place hands near working elements of the chain conveyor</p>
11		<p>Before climbing on the ladder in order to perform maintenance or repair inside the load box, turn off engine and remove key from ignition. Secure tractor against unauthorised access.</p>
12		<p>Caution! Danger of electric shock. Take particular care while working near electric power lines.</p>

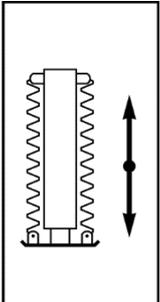
ITEM	SAFETY SYMBOL	DESCRIPTION
13		PTO RPM
14		Grease according to the recommendations in the Operator's Manual
15		Check the condition of the screw and nut connections of the wheel axles
16	<p>Łączenie tylko z zaczepem do przyczep jednoosiowych</p>	Use exclusively the hitch for single axle trailers.
17		Permissible vehicle speed
18	<p><a href="http://www.pronar.pl">www.pronar.pl</a></p>	Manufacturer's website.
19		Raising/lowering the hydraulic support (the system controlled from the manure spreader)

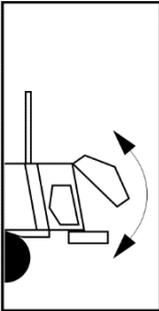
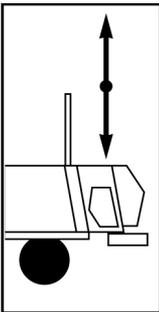
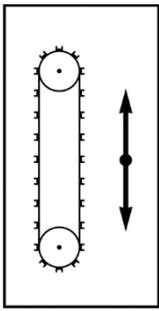
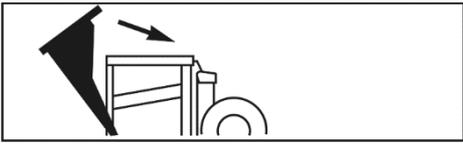
ITEM	SAFETY SYMBOL	DESCRIPTION
20		<p>Raising/lowering the rear shield of the spreader unit (the system controlled from the manure spreader)</p>
21		<p>Raising/lowering the slide gate (the system controlled from the manure spreader)</p>
22		<p>Controlling the chain conveyor operation Forward/to the rear (the system controlled from the manure spreader)</p>
23		<p>Flow direction of hydraulic oil in supply conduits <sup>(1)</sup></p>
24		<p>Hydraulic brake system supply conduit <sup>(1)</sup></p>
25		<p>Supply conduit of tailgate control system <sup>(1)</sup> (the system controlled from the tractor)</p>
26		<p>Supply conduit of the slide gate raising system <sup>(1)</sup> (the system controlled from the tractor)</p>

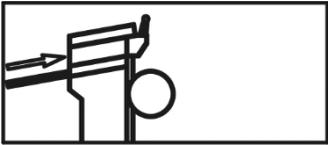
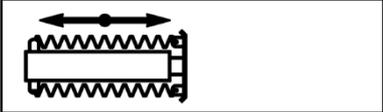
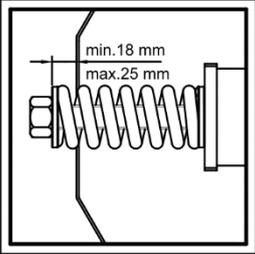
ITEM	SAFETY SYMBOL	DESCRIPTION
27		Supply conduit of the slide gate lowering system <sup>(1)</sup> (the system controlled from the tractor)
28		Supply conduit of the straight hydraulic support's control system <sup>(1)</sup> (the system controlled from the tractor)
29		Air pressure in the tyres <sup>(2)</sup>
30		Check the chain conveyor tension
31		High pressure fluid – injection into body.
32		Wait until all machine components hale completely Stoppel before touching them.

<sup>(1)</sup> - not shown in the figures, the decals are glued near the hydraulic plugs

<sup>(2)</sup> – pressure value should be adapted to tyres

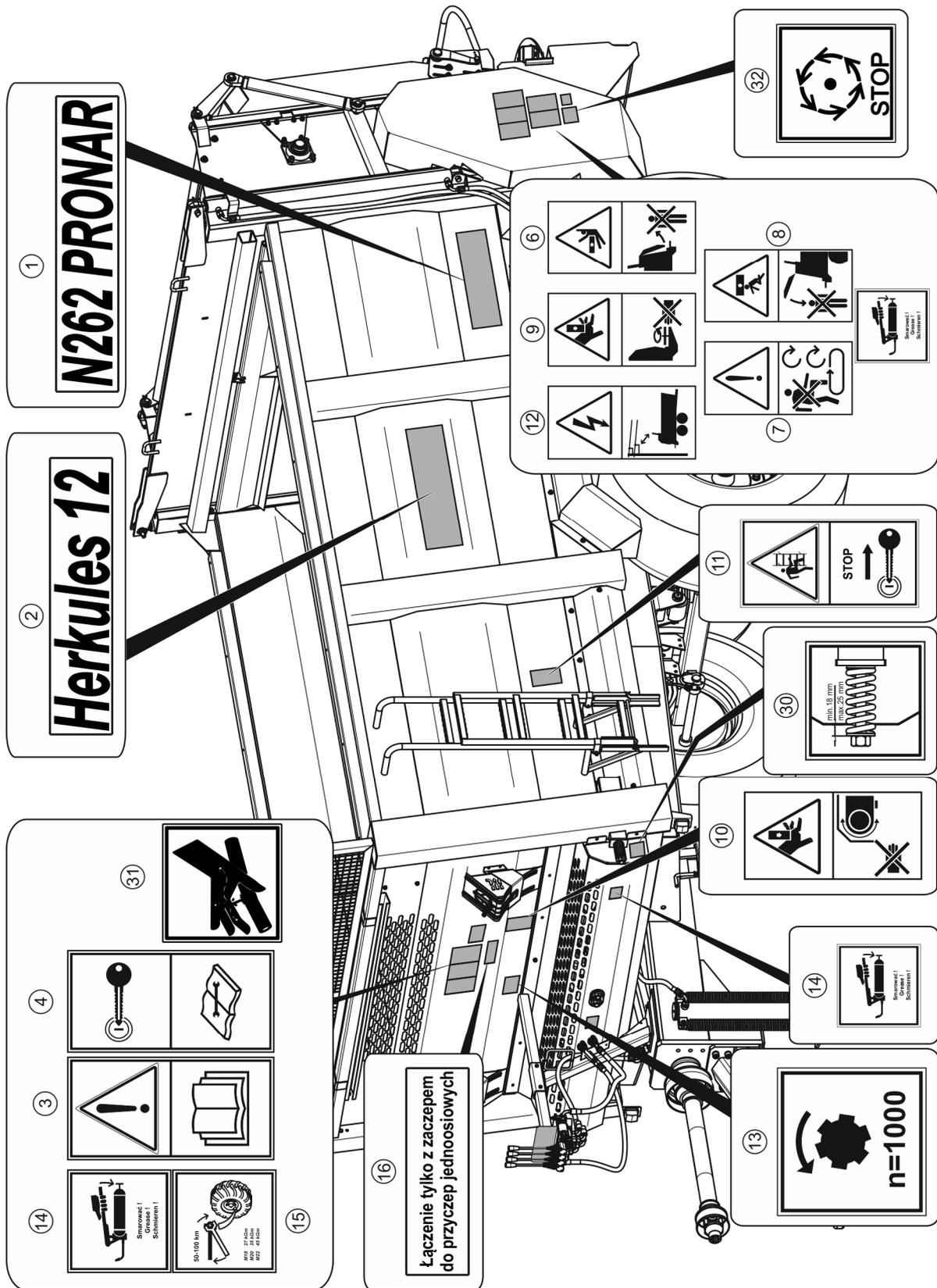

FIG. 2.3 Locations of information and warning decals N262

Labelling according to table 2.1 „Information and warning decals”

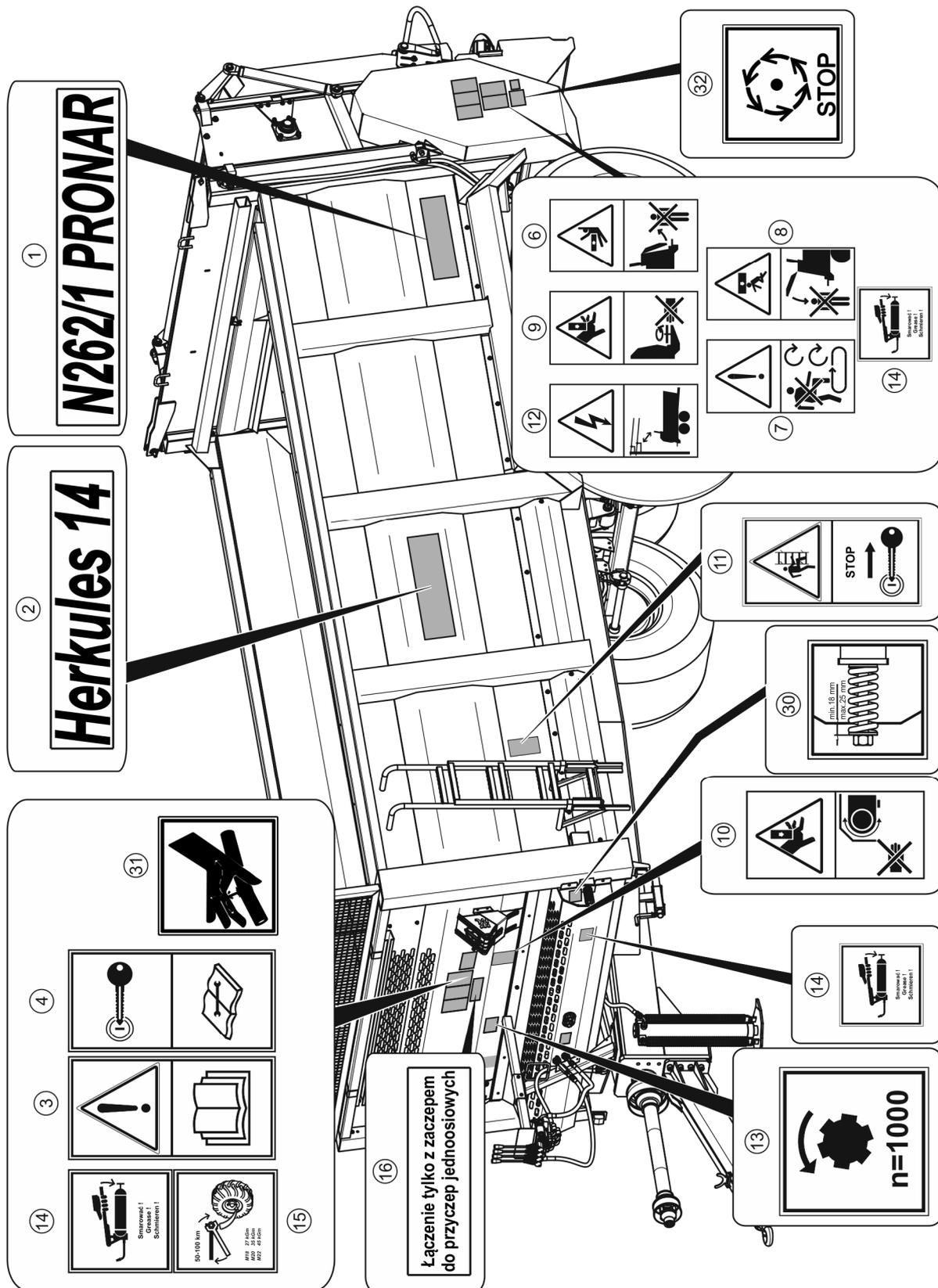
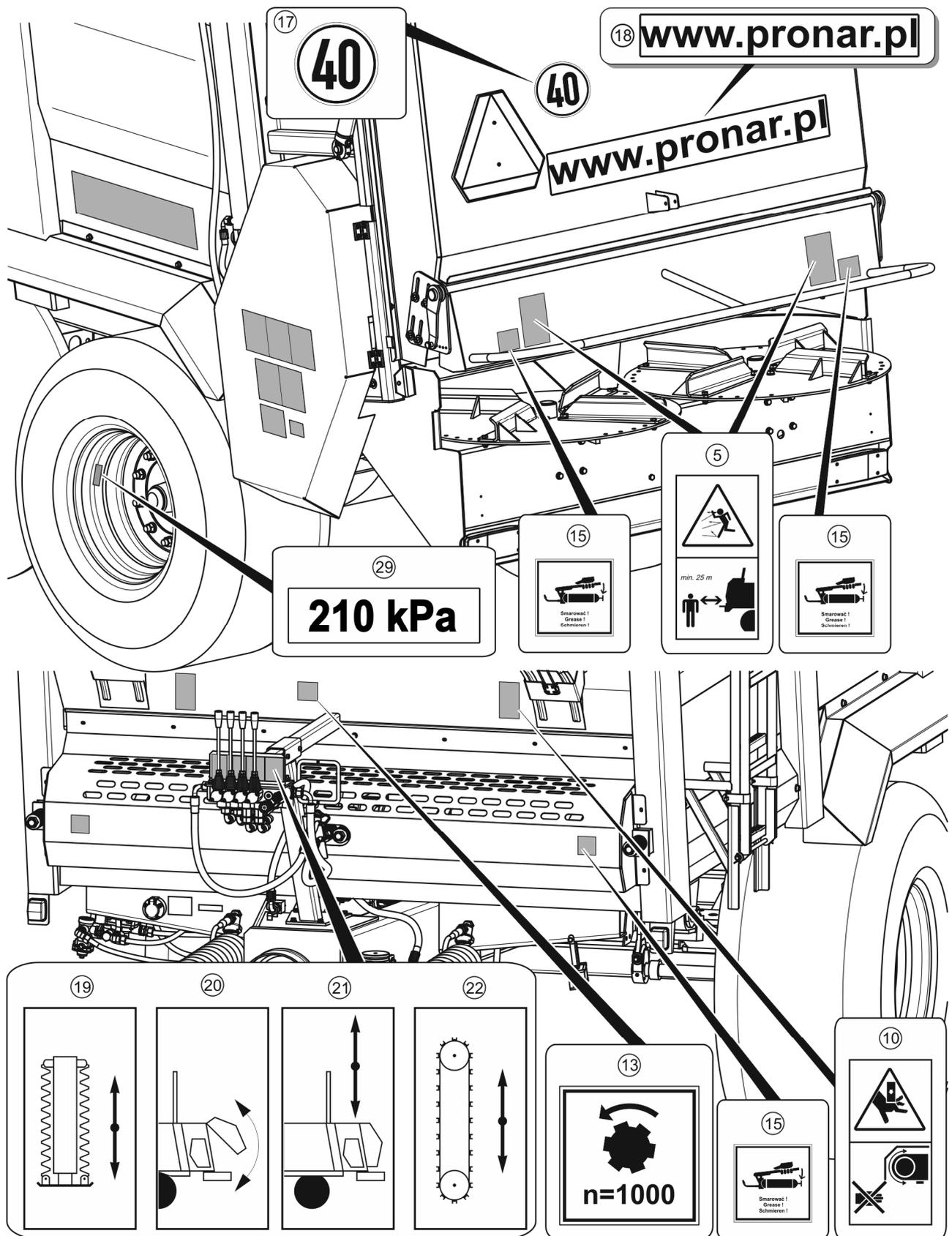

FIG. 2.4 Locations of information and warning decals N262/1

Labelling according to table 2.1 „Information and warning decals”



**FIG. 2.5** Locations of information and warning decals

Labelling according to table 2.1 „Information and warning decals”



*SECTION*

**3**

---

**DESIGN AND  
OPERATION**

## 3.1 TECHNICAL SPECIFICATION

**TAB. 3.1 Basic technical specification of N262 manure spreader**

CONTENTS	UNIT	DATA (STANDARD)	DATA (EU)
Maximum design speed	km / h	40	40
Maximum spread width	m	25	25
Cargo capacity	m <sup>3</sup>	11.3	11.3
Load surface	m <sup>2</sup>	8.9	8.9
Tare weight	kg	6 660	6 660
Carrying capacity	kg	12 000	11 340
Maximum gross weight	kg	18 660	18 000
Total length	mm	8 000	8 000
Maximum total width	mm	2 510	2 510
Total height (with net protection)	mm	3 740	3 740
Load box dimensions inside:			
- length	mm	4 500	4 500
- width (front/rear)	mm	1 955/1 995	1 955/1 995
- height (with a wooden protective strip)	mm	1 265	1 265
Wheel track	mm	1 900	1 900
Height of floor from ground	mm	1 530	1 530
Tractor power demand (minimum)	hp \ kW	127.3 / 93.6	127.3 / 93.6
PTO drive	RPM	1 000	1 000
Rotation speed of disintegrating drums	RPM	518	518
Rotation speed of discs	RPM	357	357
Clutch overload torque	Nm	1 500	1 500
Electrical system voltage	V	12	12
Drawbar eye load	kg	2 200	2 500 -3 000
Hydraulic oil demand:			
- hydraulic system	l	6.5	6.5

**TAB. 3.2 Basic technical specification of N262/1 manure spreader**

<b>CONTENTS</b>	<b>UNIT</b>	<b>DATA (STANDARD)</b>	<b>DATA (EU)</b>
Maximum design speed	km / h	40	40
Maximum spread width	m	25	25
Cargo capacity	m <sup>3</sup>	14	14
Load surface	m <sup>2</sup>	11.1	11.1
Tare weight	kg	7 200	7 200
Carrying capacity	kg	14 000	10 800
Maximum gross weight	kg	21 200	18 000
Total length	mm	9 000	9 000
Maximum total width	mm	2 550	3 000
Total height (with net protection)	mm	3 740	3 740
Load box dimensions inside:			
- length	mm	5 600	5 600
- width (front/rear)	mm	1 955/1 995	1 955/1 995
- height (with a wooden protective strip)	mm	1 265	1 265
Wheel track	mm	1 940	1 940
Height of floor from ground	mm	1 530	1 530
Tractor power demand (minimum)	hp \ kW	147.4 / 108.3	147.4 / 108.3
PTO drive	RPM	1 000	1 000
Rotation speed of disintegrating drums	RPM	518	518
Rotation speed of discs	RPM	357	357
Clutch overload torque	Nm	1 500	1 500
Electrical system voltage	V	12	12
Drawbar eye load	kg	2 200	2 500 -3 000
Hydraulic oil demand:			
- hydraulic system	l	6.5	6.5

## 3.2 MANURE SPREADER DESIGN

### 3.2.1 MANURE SPREADER BODY

Manure spreader design is shown on figure (3.1). Lower frame (1) is a structure welded from steel sections. The main support elements are two longitudinal members connected with crossbars. Load box (2) is welded to the frame. Manure spreader suspension consists of two wheel axles (3), in a tandem arrangement suspended on taper leaf springs connected by rocker arm (4). Axles are secured to suspension springs using absorber plates and U bolts. Axles are made from square bars terminated with a pin, where wheel hubs are mounted on cone bearings. The wheels are single, equipped with brake shoes activated through mechanical expander cams.

Depending on the type of agricultural tractor hitch to be used, the manure spreader can be equipped with a lower drawbar (5) or upper drawbar (6). One of the available drawbar eyes is attached to faceplate of lower drawbar - figure (3.1) .

- rotating drawbar (7) with eye of  $\varnothing 50$  mm,
- ball drawbar eye K80 (8),
- rotating drawbar with eye of  $\varnothing 52$  mm (only version standard).

Fixed drawbar eye (10) with eye of  $\varnothing 40$  mm diameter is attached to faceplate of upper drawbar – see chapter 5.16 „*ADJUSTMENT OF THE UPPER DRAWBAR EYE POSITION*”

Hydraulic support (11) is attached to the side plate of the frame in the front section of the manure spreader. Depending on the order placed, the elements of the hydraulic system for controlling the manure spreader from the spreader itself or from the tractor are installed on bracket (12).

Horizontal spreader unit (13) and a wide spread mechanism (14) are installed in the rear section of the load box. Between the load box space and the spreader unit there is a movable slide gate (15). Tailgate (16) is installed behind the spreader unit. Protective wooden beams (17) are mounted on the side walls of the load box. Net protection (18) is installed in the front section of the load box. On customer request, the manure spreader can be equipped with a rear beam (19).

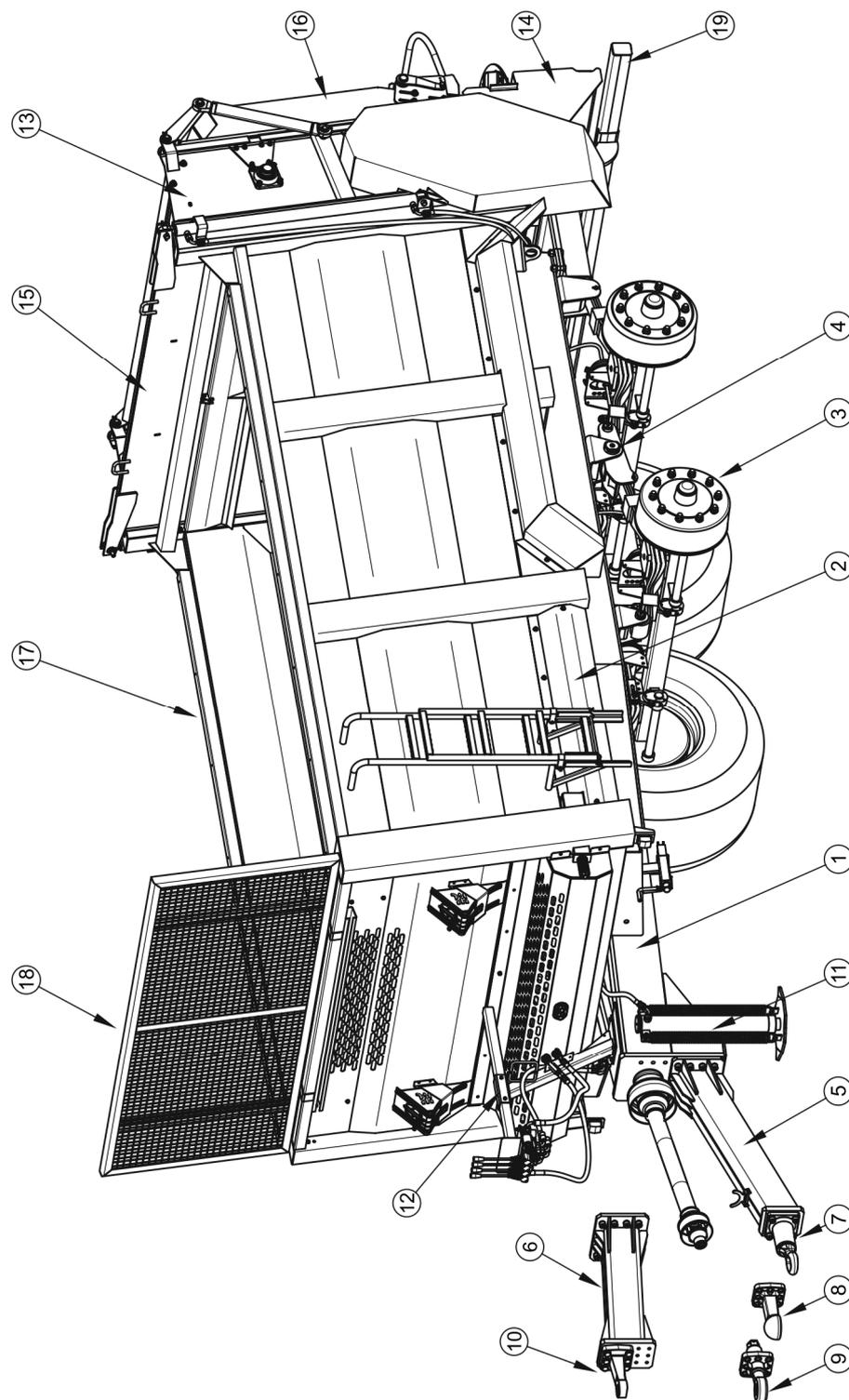

**FIG. 3.1 Manure spreader body N262**

(1) lower frame, (2) load box, (3) wheel axle, (4) shock absorber rocker arm, (5) lower drawbar, (6) upper drawbar, (7) rotating drawbar eye  $\varnothing 50$ , (8) ball drawbar eye, (9) rotating drawbar eye  $\varnothing 52$ , (10) fixed drawbar eye  $\varnothing 40$ , (11) support, (12) bracket, (13) spreader unit, (14) wide spread mechanism, (15) slide gate, (16) tailgate, (17) protective beam, (18) net protection, (19) rear beam

### 3.2.2 FEEDING MECHANISM

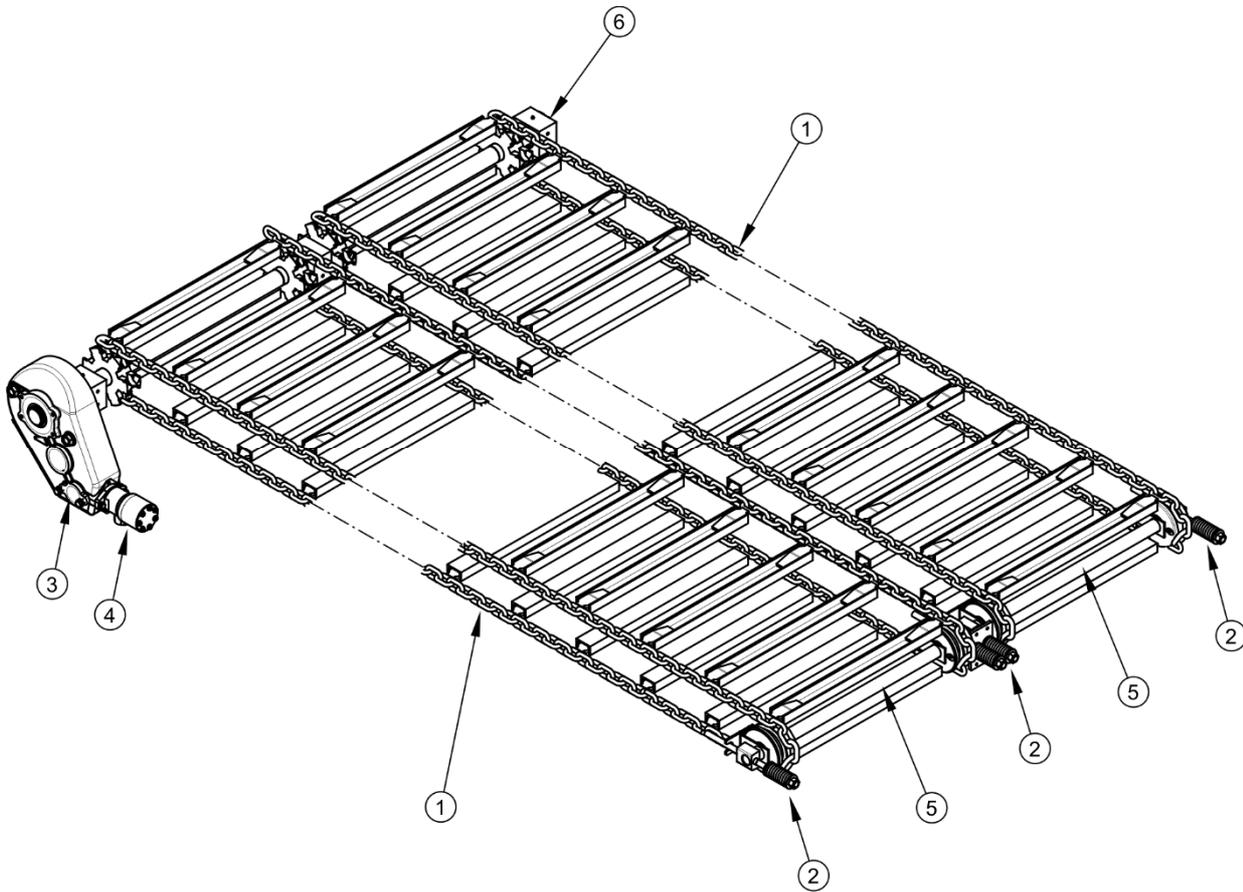

**FIG. 3.2 Feeding mechanism**

(1) transfer assembly, (2) tensioning bolt, (3) reduction gear, (4) hydraulic motor, (5) tensioning unit axis, (6) drive mechanism shaft

Feeding mechanism of the manure spreader consists of two transfer assemblies (1). The transfer assembly consists of two chains and scraper strips. The chains of the transfer assembly are seated on cast iron gear wheels of drive mechanism shaft (6) and on front wheels of the tensioning assembly (5).

Tension is adjusted using four tensioning bolts (2) with shock absorbing springs. The transfer assemblies are driven by hydraulic motor (4) coupled with reduction gear (3).

Principles of conveyor speed adjustment are presented in chapter 4.5 – figure (4.2), and (4.3) whereas the method of adjusting the tension of floor conveyor chains is described in chapter 5.14 - figure (5.15).

**IMPORTANT**

Movement direction of loaded feeding mechanism may be reversed only for a short time.

The feeding mechanism may be started only if the manure spreader's slide gate is raised. Otherwise, the manure spreader may be seriously damaged.

**3.2.3 HYDRAULIC SYSTEM OF FEEDING MECHANISM (SYSTEM CONTROLLED FROM THE TRACTOR)**

Hydraulic system of feeding mechanism is used for controlling the floor conveyor. The system is supplied by the external tractor hydraulic system through the hydraulic conduits (5) and (6). Decals (item 23 - table (2.1)) in the form of arrows indicating the direction of hydraulic oil flow are located on conduits, near the connection plugs, in order to identify the conduits. The system is connected to hydraulic motor (2) which drives the floor conveyor.

The system is equipped with an overload valve (3) which protects the system against excessive increase of pressure above the rated operating pressure of the manure spreader. If the flow is blocked and pressure in the system has achieved the limit level, the overload valve opens and releases excess of oil to return conduit. In this way, the complete system is protected against overload and possible damage.

The system is controlled by means of the manifold in the tractor cab. Such a solution enables change of conveyor movement direction and shortens reaction time. The conveyor speed is adjusted using a knob on hydraulic flow regulator (1) within scale from 0 to 10. The flow regulator is installed on the conduit outrigger in the front section of the manure spreader. The maximum flow rate (maximum conveyor speed) is achieved if flow regulator setting is 10, while the minimum flow rate is achieved if flow regulator setting is 0. Design and diagram of hydraulic system of feeding mechanism is shown in figure (3.3).

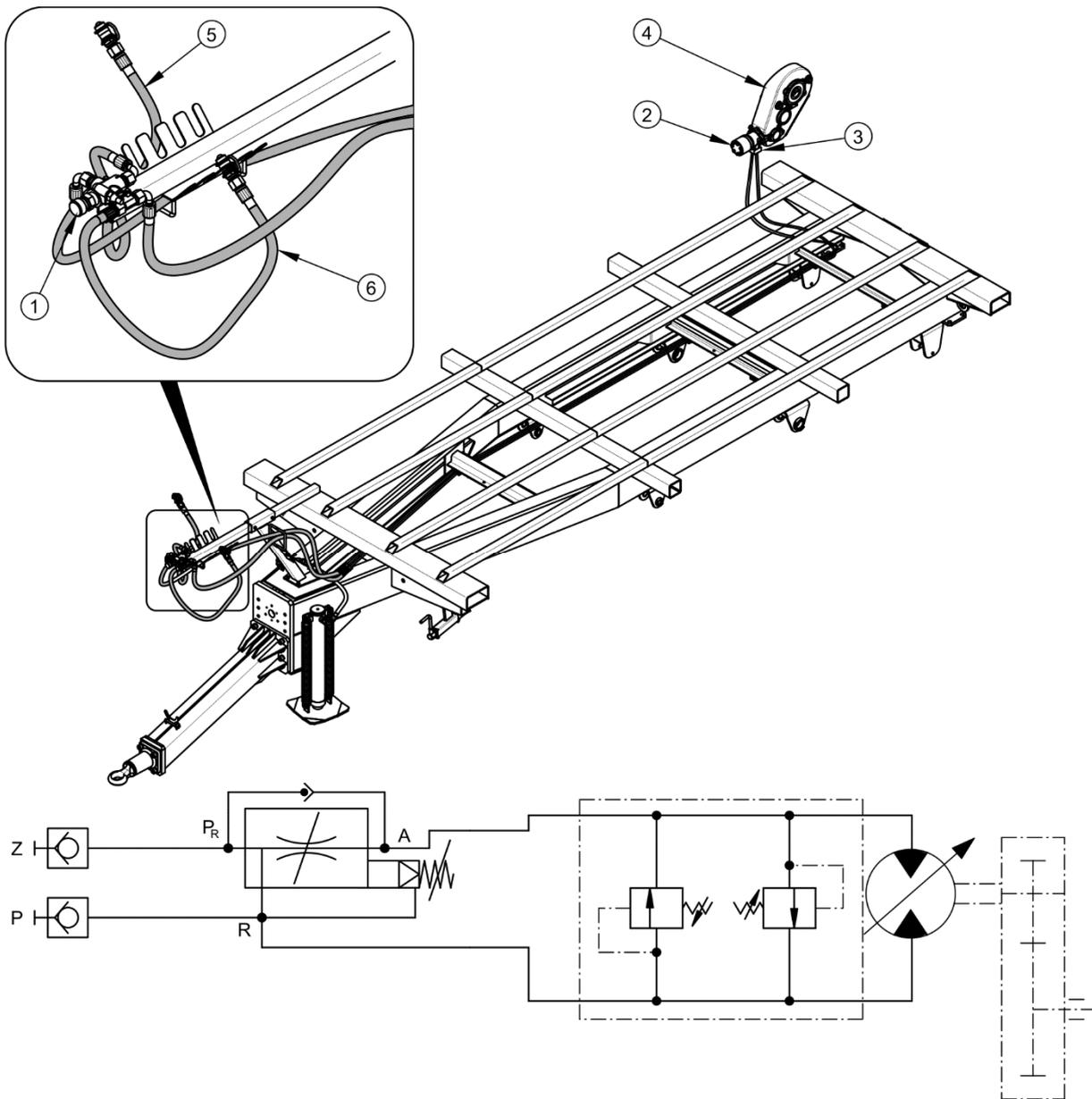

**FIG. 3.3 Design and diagram of hydraulic system of feeding mechanism**

(1) flow rate regulator, (2) hydraulic motor, (3) overload valve, (4) reduction gear, (5) supply conduit, (6) return conduit, (Z) supply, (P) return, (R) return (regulator), (P<sub>R</sub>) supply (regulator), (A) receiver (hydraulic motor)

### 3.2.4 HYDRAULIC SYSTEM OF STRAIGHT SUPPORT (SYSTEM CONTROLLED FROM THE TRACTOR)

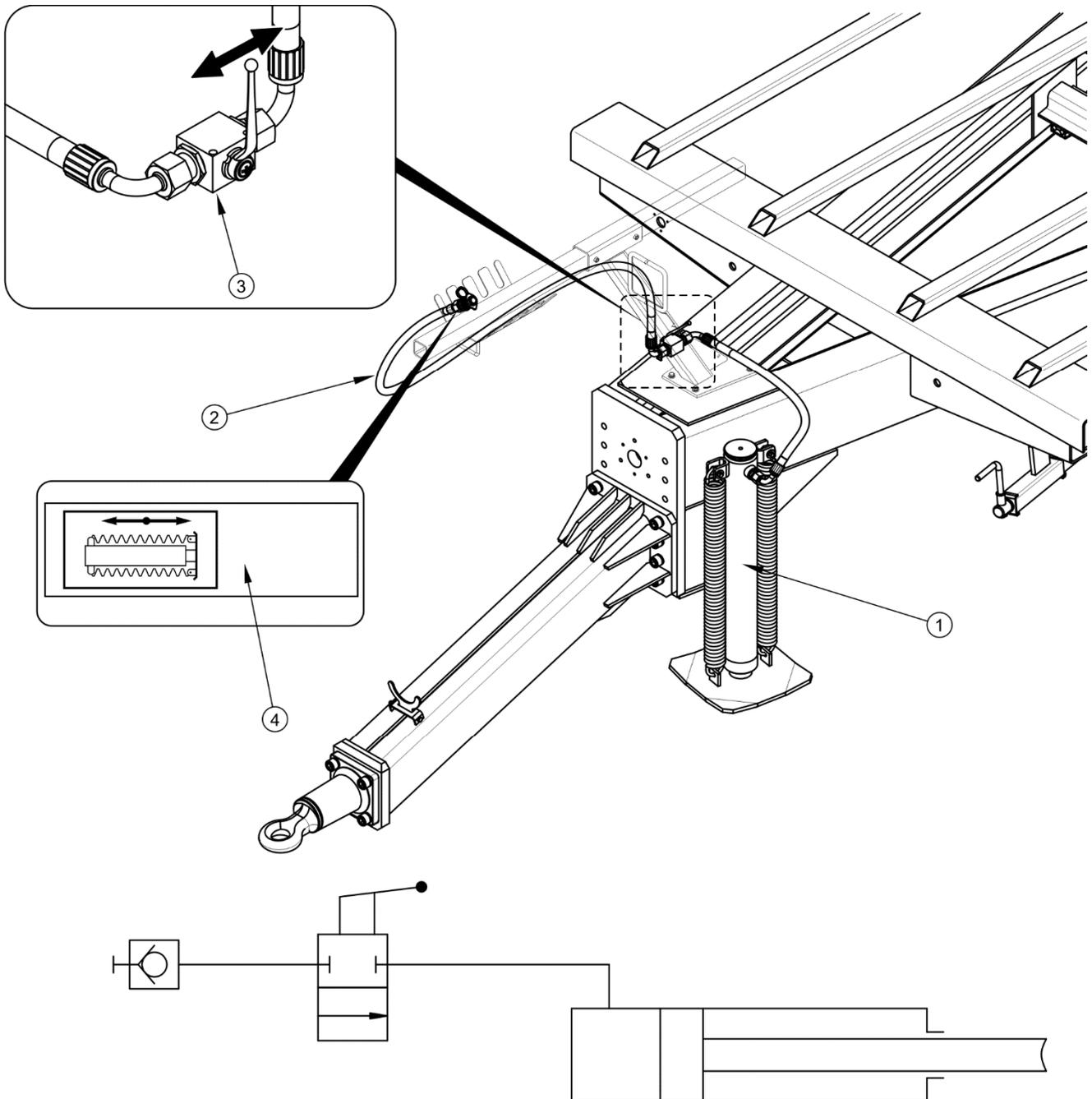

**FIG. 3.4** Straight support hydraulic system construction and diagram

(1) hydraulic support, (2) connection conduit, (3) valve, (4) information decal

Support hydraulic system is used for automatic unfolding of the support by extending the hydraulic cylinder piston. The system is supplied with oil from the hydraulic system of the tractor through connection conduit (2) marked with a decal (4) located near the connection

plug. Hydraulic oil selective control valve of the tractor's external hydraulic system is used to control the extending of the support cylinder.

Lowering the straight hydraulic support (1) is done by opening the valve (3) on the spreader frame. Hydraulic oil supplied from hydraulic selective control valve extends the cylinder ram to the desired height. After the pressure in hydraulic conduit is reduced, withdrawal of the parking stand to transport position is forced by means of springs – figure (3.4).

**TIP**

The hydraulic system of the support is filled with L-HL32 Lotos hydraulic oil.

### 3.2.5 HYDRAULIC SYSTEM OF TAILGATE (SYSTEM CONTROLLED FROM THE TRACTOR)

The hydraulic system of the tailgate controls raising and lowering of the manure spreader's tailgate. The hydraulic system is supplied with oil from the tractor external hydraulic system. The system is controlled from the tractor cab using the manifold lever. Pressurised oil is supplied through hydraulic conduit (4) marked with information decal (5) to hydraulic cylinders (2), which raise the tailgate (1). The tailgate is lowered after the pressure in hydraulic conduit is reduced.

The system is equipped with a hydraulic cut-off valve (3) which prevents a sudden closing of the tailgate while performing maintenance work.

**ATTENTION**

During service with the tailgate raised, protect it from falling down by closing the cut-off valve and with a suitable mechanical support which is durable and stably mounted.

Take care not to lower or rise the tailgate when it is locked using a cut-off valve. Otherwise, hydraulic cylinders and/or tailgate may be damaged.

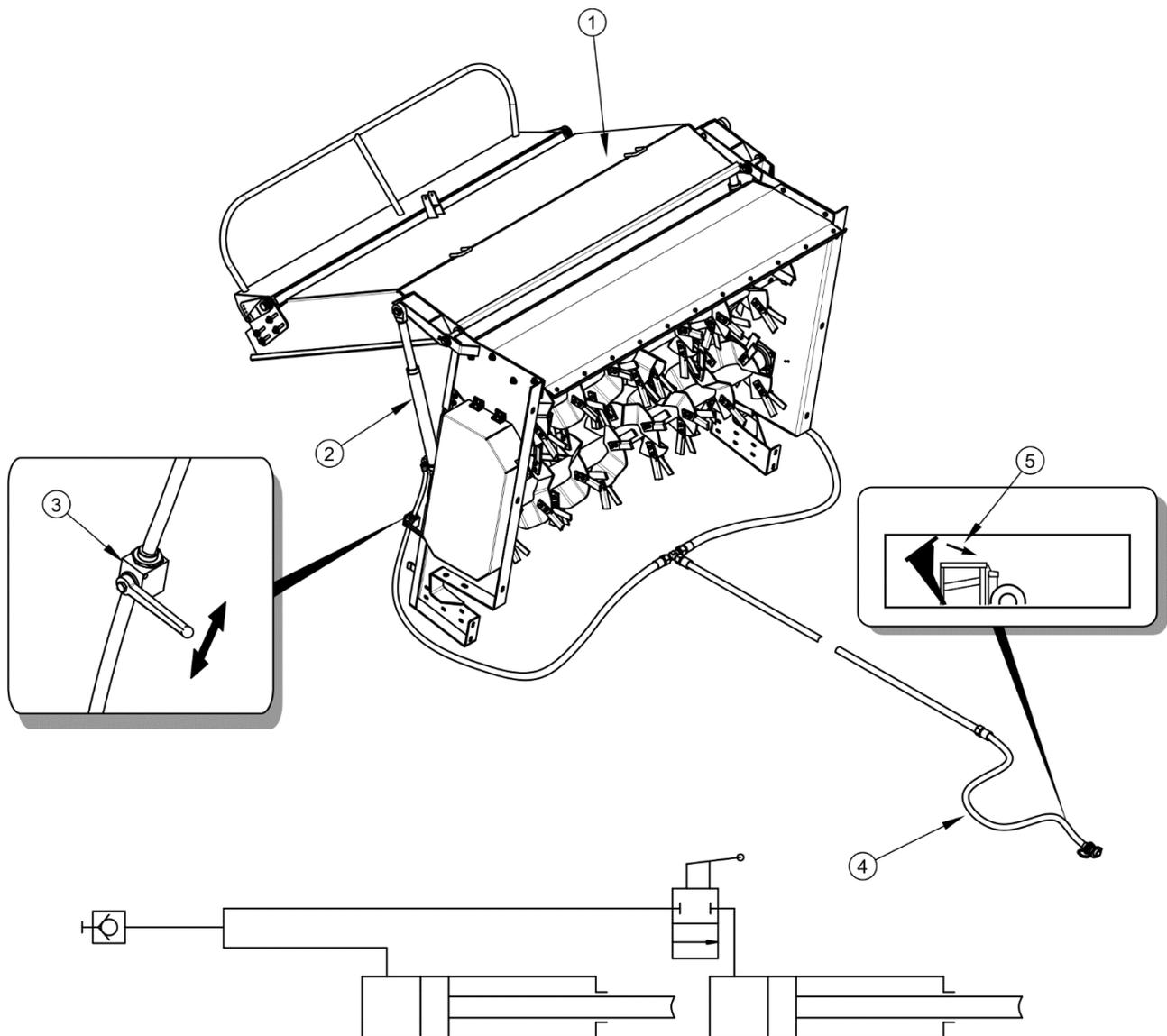

**FIG. 3.5 Tailgate hydraulic system construction and diagram**

(1) tailgate, (2) hydraulic cylinder, (3) cut-off valve, (4) supply conduit, (5) information decal

### 3.2.6 HYDRAULIC SYSTEM OF SLIDE GATE (SYSTEM CONTROLLED FROM THE TRACTOR)

Pronar manure spreader is equipped with a load box slide gate. The slide gate is mounted in front of the spreader unit and it ensures safe transport of disintegrated materials (e.g. compost, peat) on public roads and ensures safe start of disintegrating wormshafts.

The load box slide gate is controlled hydraulically. This hydraulic system is supplied from the external hydraulic system of the tractor. The hydraulic cylinders opening and closing the slide gate are controlled by means of the manifold in the tractor cab.

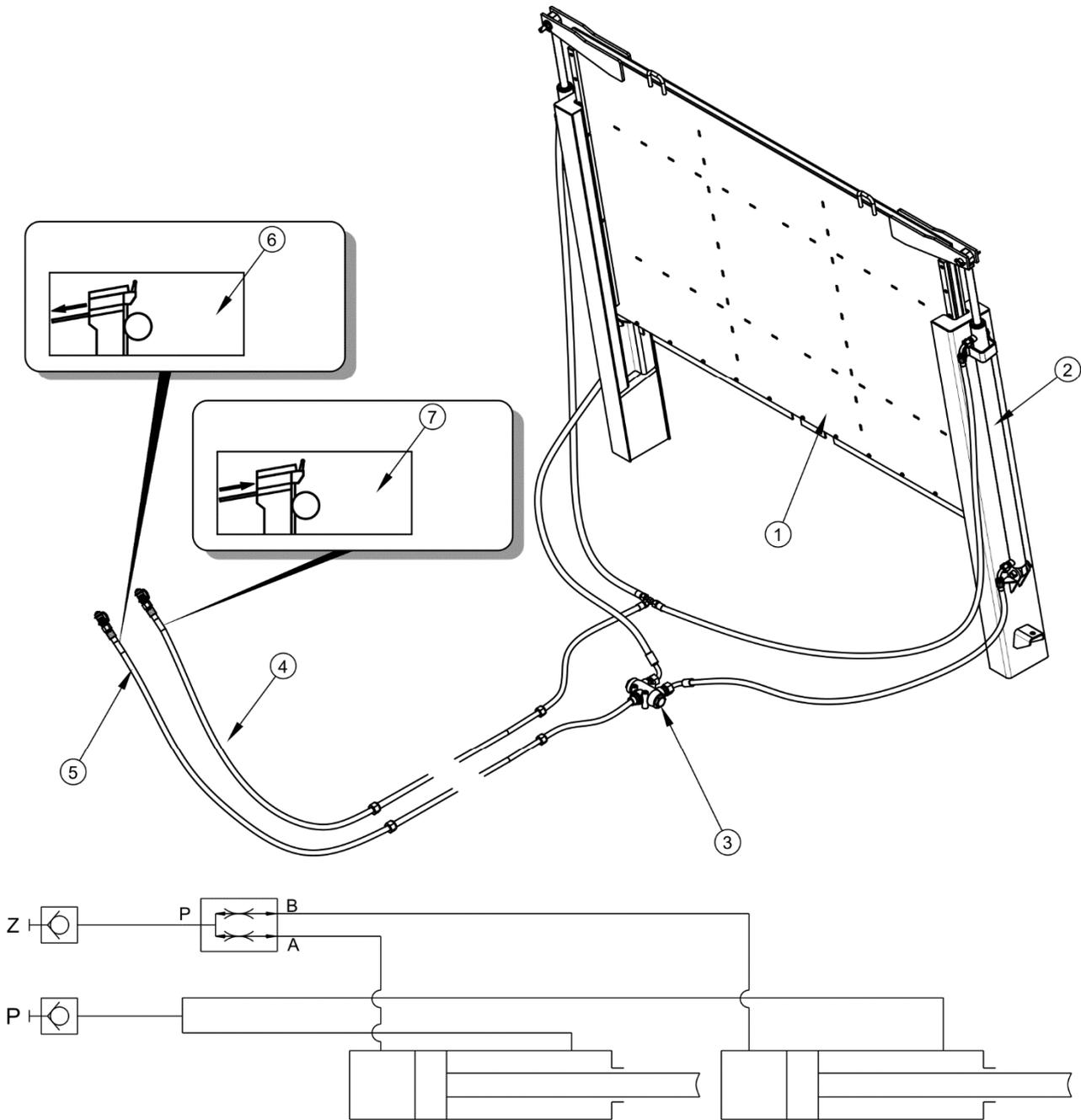

**FIG. 3.6 Design and diagram of the slide gate's hydraulic system**

(1) slide gate, (2) hydraulic cylinder, (3) flow divider, (4) return conduit, (5) supply conduit, (6), (7) information decals, (Z) supply, (P) return

Oil pumped under pressure from the tractor external hydraulic system through a supply conduit (5) enters the flow divider (3) which separates the oil stream proportionally to the two hydraulic cylinders (2) causing the cylinder rods move steadily upwards to open the slide gate (1).

The slide gate is closed by changing the position of manifold lever in the tractor. Then, oil is pumped through conduit (4) to cylinders (2). Consequently, the cylinder rods are moved downwards and the slide gate is closed.

### 3.2.7 HYDRAULIC SYSTEM (CONTROLLED FROM THE MANURE SPREADER)

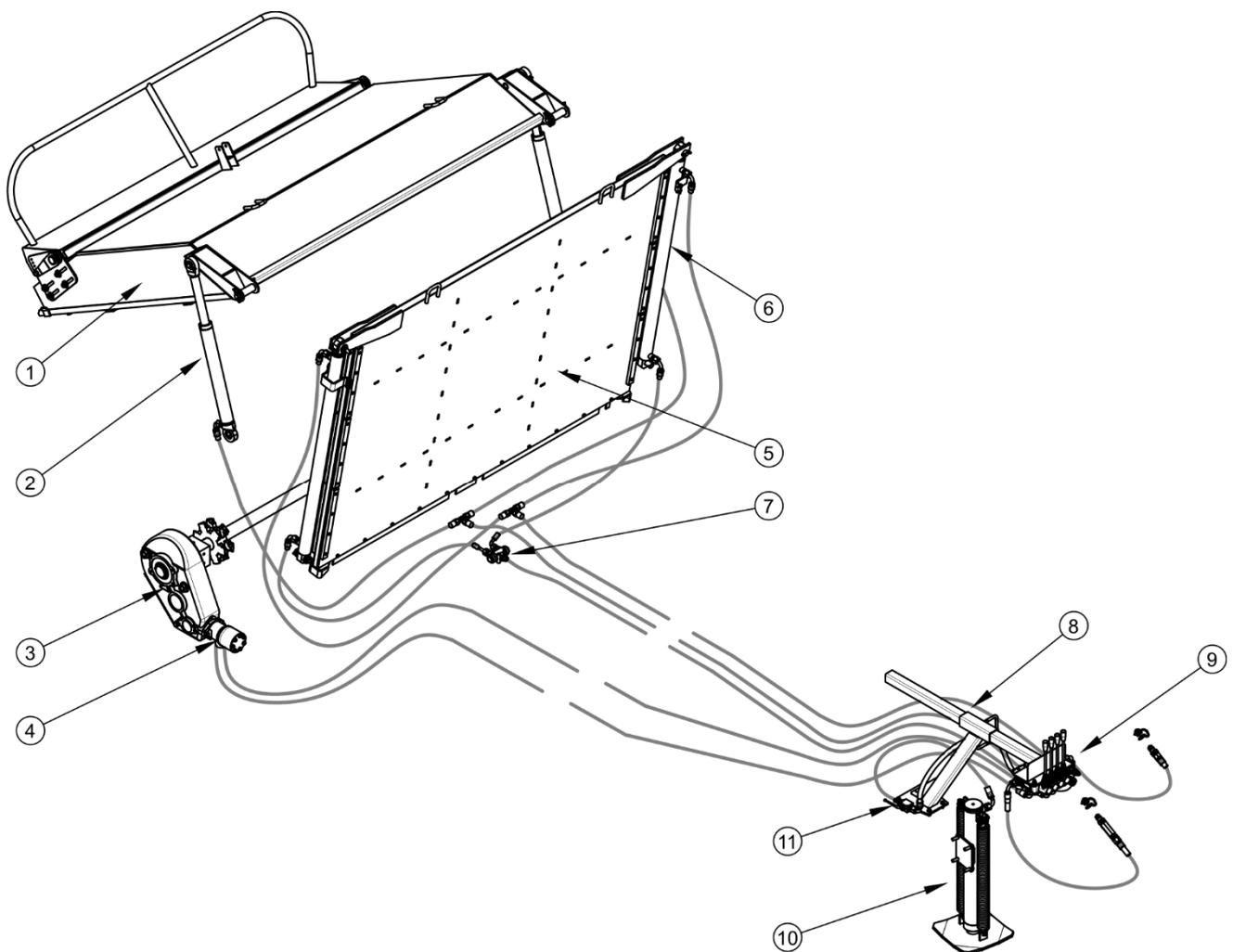
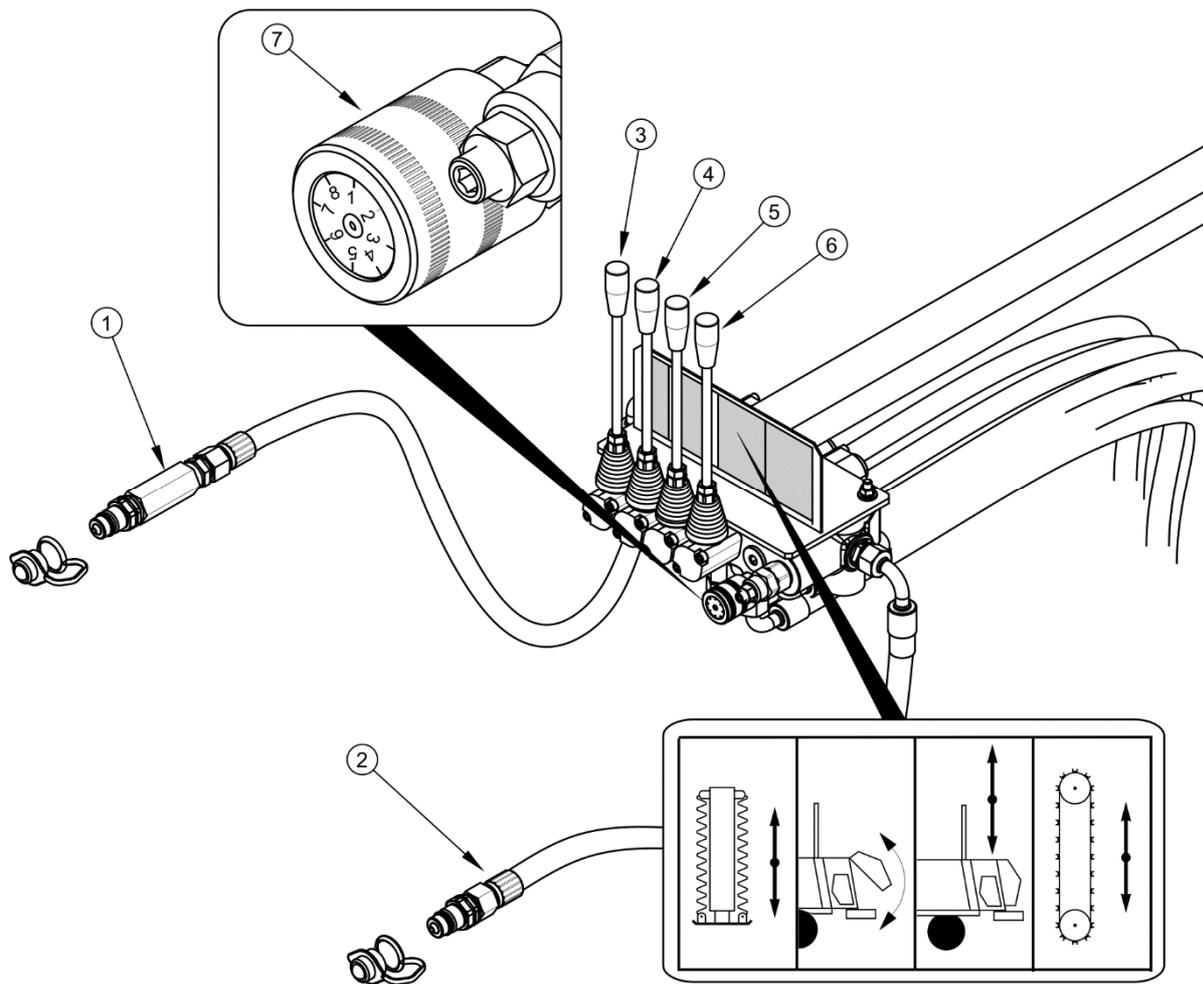

**FIG. 3.7** Hydraulic system design (system controlled from the manure spreader)

(1) tailgate, (2) tailgate raising cylinder, (3) reducer, (4) hydraulic motor, (5) slide gate, (6) slide gate cylinder, (7) flow divider, (8) outrigger, (9) hydraulic manifold, (10) hydraulic support, (11) valve

The manure spreader's hydraulic system consists of four independent circuits controlling the machine's individual subassemblies:

- hydraulic support,
- tailgate of spreader unit,
- slide gate,
- chain conveyor drive.



**FIG. 3.8 Hydraulic selective control valve**

(1) return conduit with a check valve, (2) supply conduit, (3) control of hydraulic support, (4) control of tailgate, (5) control of slide gate, (6) control of chain conveyor, (7) chain conveyor speed adjusting knob

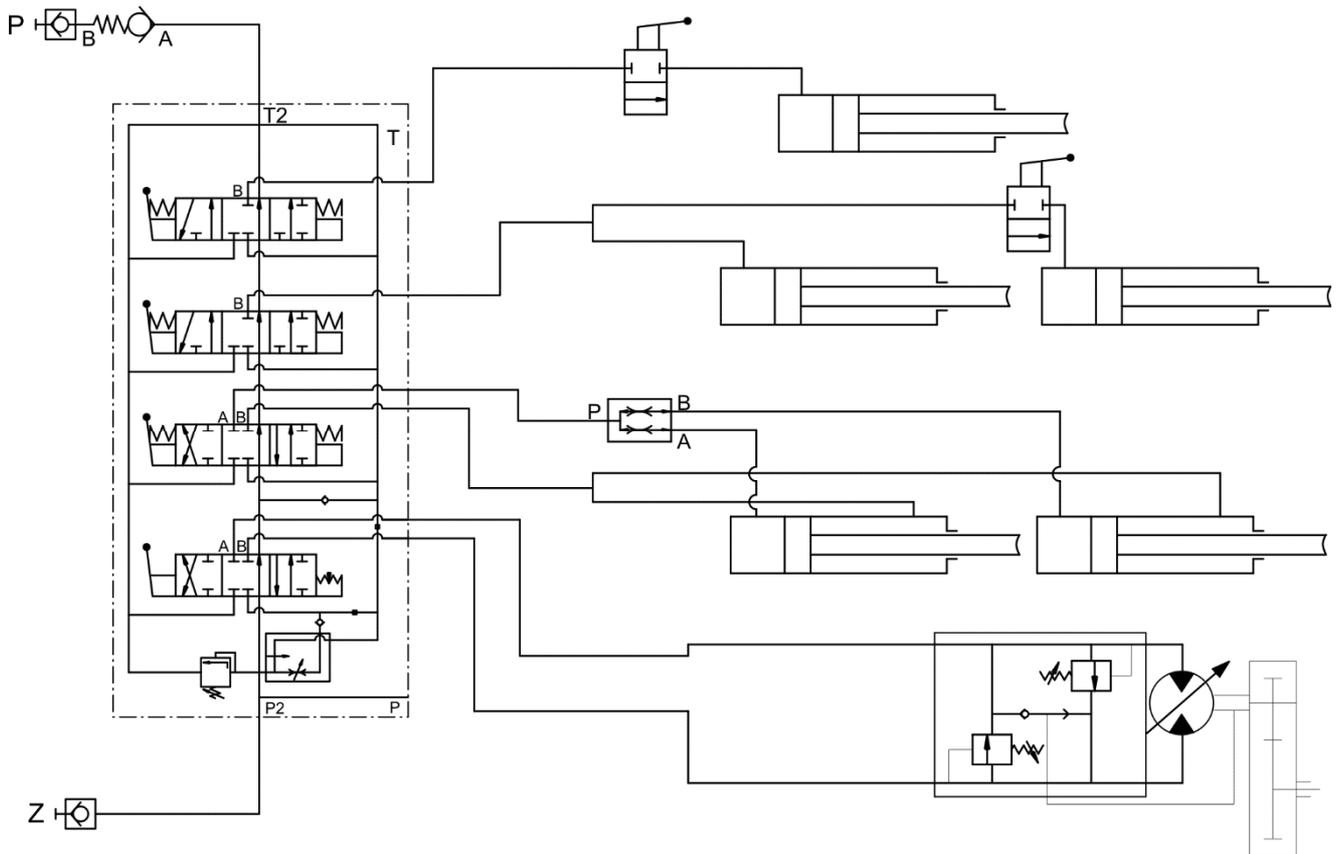

**FIG. 3.9 Hydraulic system diagram (system controlled from the manure spreader)**

*(Z) supply, (P) return*

### 3.2.8 SPREADER UNIT

The complete unit consists of a spreader unit and a wide spread mechanism. The spreader unit is attached to the load box in the rear section of the manure spreader. The spreader unit is equipped with two horizontally seated wormshafts (3) mounted in bearing assemblies. The wormshafts are equipped with knives (working tools), which ensure proper disintegration of manure. The knives are bolted and can be replaced with new ones.

Manure supplied by floor conveyor to spreader unit is received and disintegrated by wormshafts and spread by wide spread mechanism discs (2). This subassembly is located under the disintegrating unit. It consists of a housing and two discs equipped with blades.

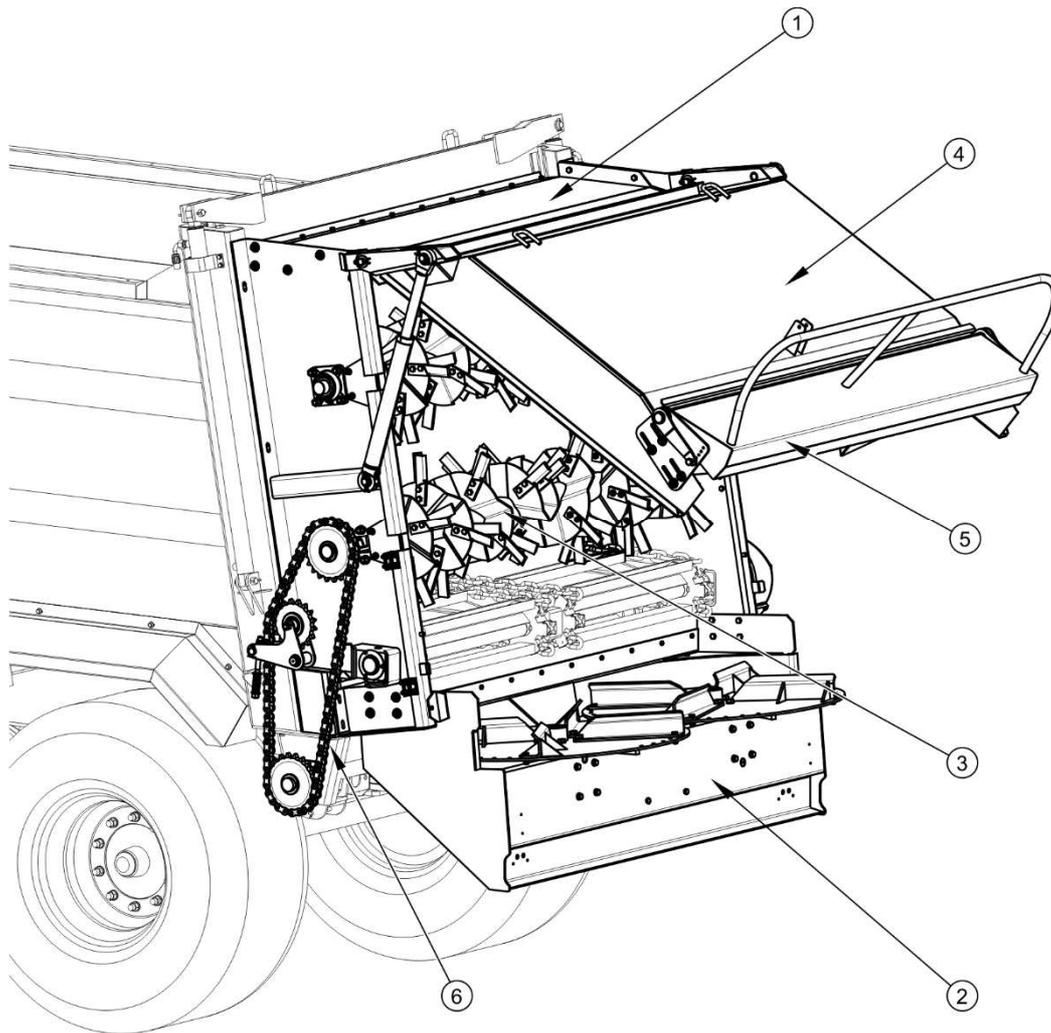

**FIG. 3.10 Spreader unit**

(1) *spreader unit housing*, (2) *wide spread mechanism*, (3) *wormshaft*, (4) *tailgate*, (5) *adjusting shield*, (6) *drive chain*

	<p><b>IMPORTANT</b></p> <p>The slide gate should be maximally raised when the spreader unit is working.</p> <p>The rotation speed of the tractor PTO shaft driving the spreader unit must be 1 000 rpm.</p>
---	---

**3.2.9 DRIVE TRANSMISSION**

Spreader unit is driven by the drive transmission whose design is shown in Figure (3.11). Located on the spreader lower frame faceplate there is a PTO connector (11) terminated with the spline tip, to which the tractor PTO shaft (1) is connected.

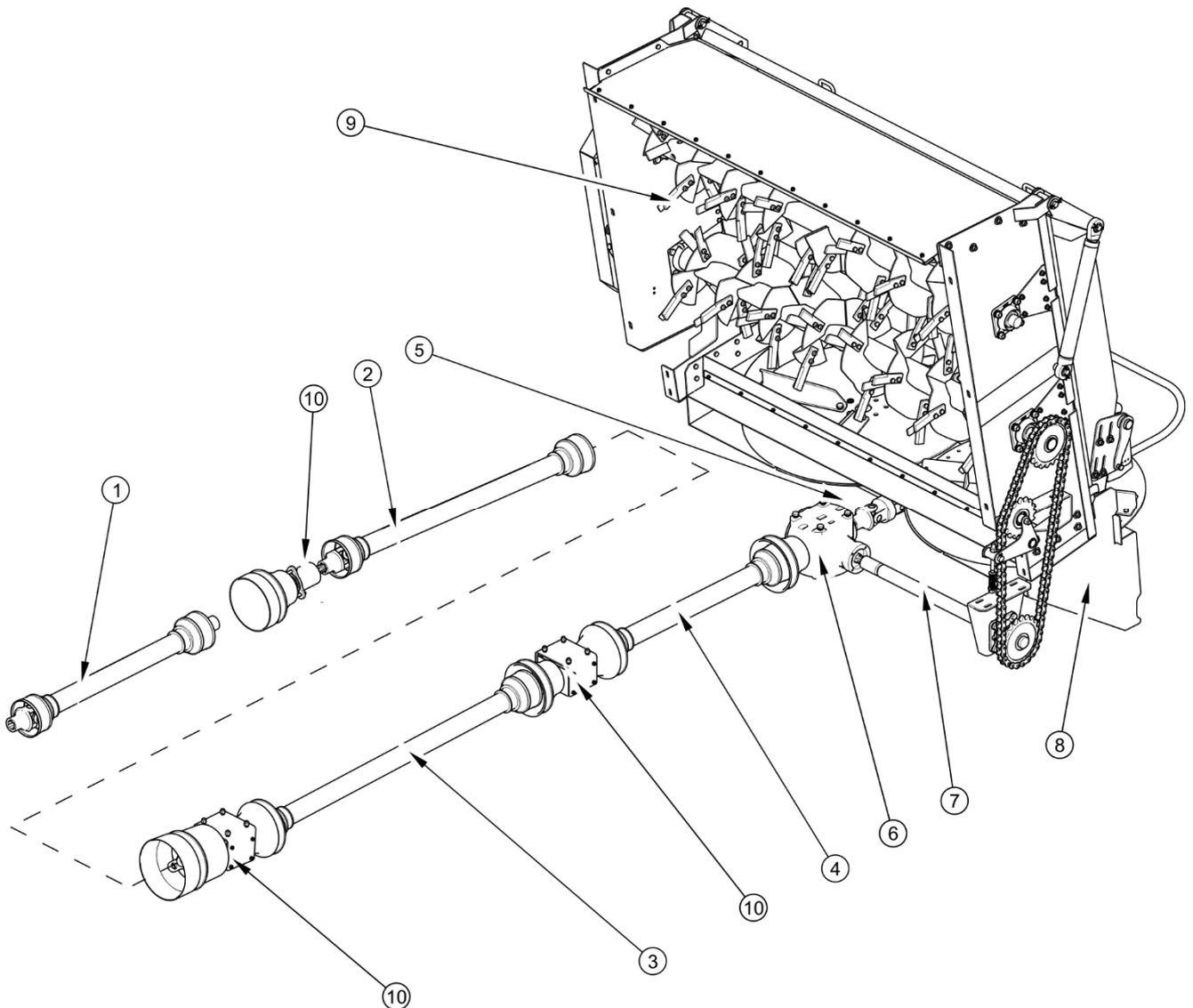

**FIG. 3.11 Drive transmission**

(1) PTO shaft for connection with tractor (option), (2) PTO shaft with automatic clutch, (3) PTO shaft with one-way clutch, (4) PTO shaft, (5) articulated joint, (6) reduction gear, (7) spreader unit drive shaft, (8) wide spread mechanism, (9) spreader unit, (10) PTO connector

Torque is transmitted from the tractor through PTO shafts (1), (2), (3), (4) to reduction gear (6). The drive is transferred from the reduction gear, through the spreader unit drive shaft (7), to chain transmission and then to the lower wormshaft of the spreader unit. The chain transmission located on the opposite side transmits drive from the lower wormshaft to the upper wormshaft.

The drive is transferred to wide spread mechanism (8) from reduction gear (6) by means of articulated joint (5) equipped with a one-way clutch.

PTO shaft with automatic clutch (2) is the safety element which interrupts the transmission of power, when the torque exceeds the calibrated value of the clutch. Automatic recoupling occurs when the speed is reduced or power take off is stopped.



### **IMPORTANT**

**Do NOT use PTO rotation speed other than 1,000 rpm. If PTO shaft works at a different speed, rotation speed of disintegrating wormshafts will be insufficient and the drive will be at the risk of damage.**

### **3.2.10 MAIN BRAKE**

The manure spreader is equipped with one of three types of working brake:

- Double line pneumatic system that can also be used as a single line system, figure (3.12) (see section 4.1.2 for details on how to configure the system),
- double line pneumatic brake system with automatic regulator, figure (3.13),
- hydraulic brake system, figure (3.14),

Working brake is activated from the tractor driver's cab by pressing on the brake pedal in the tractor. The function of the control valve (2), applied in pneumatic systems - figure (3.12), (3.13), is the operation of the manure spreader brakes simultaneously when tractor's brakes are applied. Furthermore, in case of an inadvertent disconnection of the line between the manure spreader and the tractor, the control valve will automatically activate machine's brakes. Valve used in the system is equipped with a brake to be applied when manure spreader is disconnected from the tractor. When compressed air line is connected to the tractor, the device automatically applying the brakes now changes its position to allow normal brake operation.

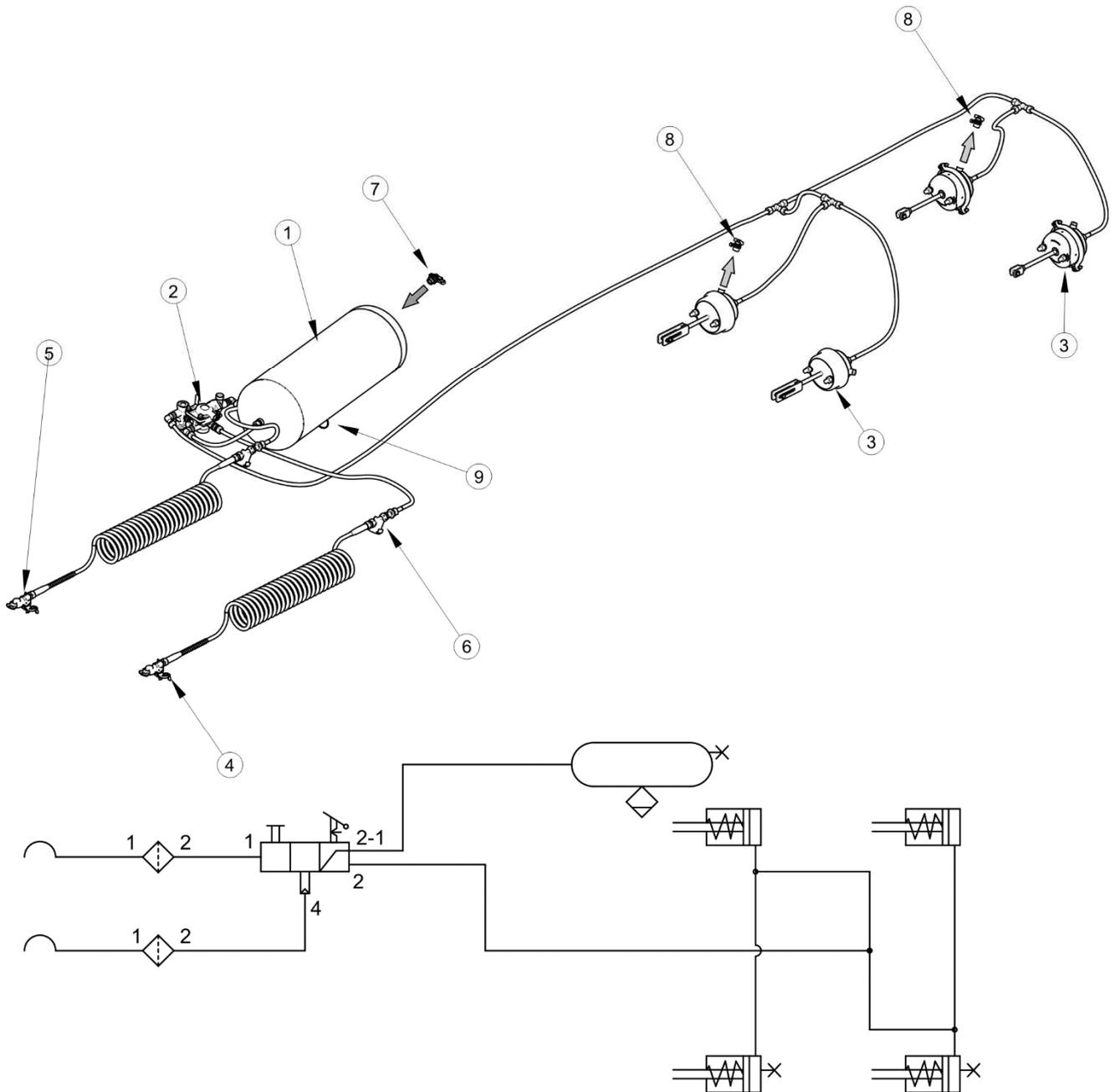

**FIG. 3.12 Double line pneumatic system**

(1) air tank, (2) control valve with braking force regulator, (3) pneumatic cylinder, (4) line connector (yellow), (5) line connector (red), (6) air filter, (7) air tank control connector, (8) pneumatic cylinder control connector, (9) drain valve

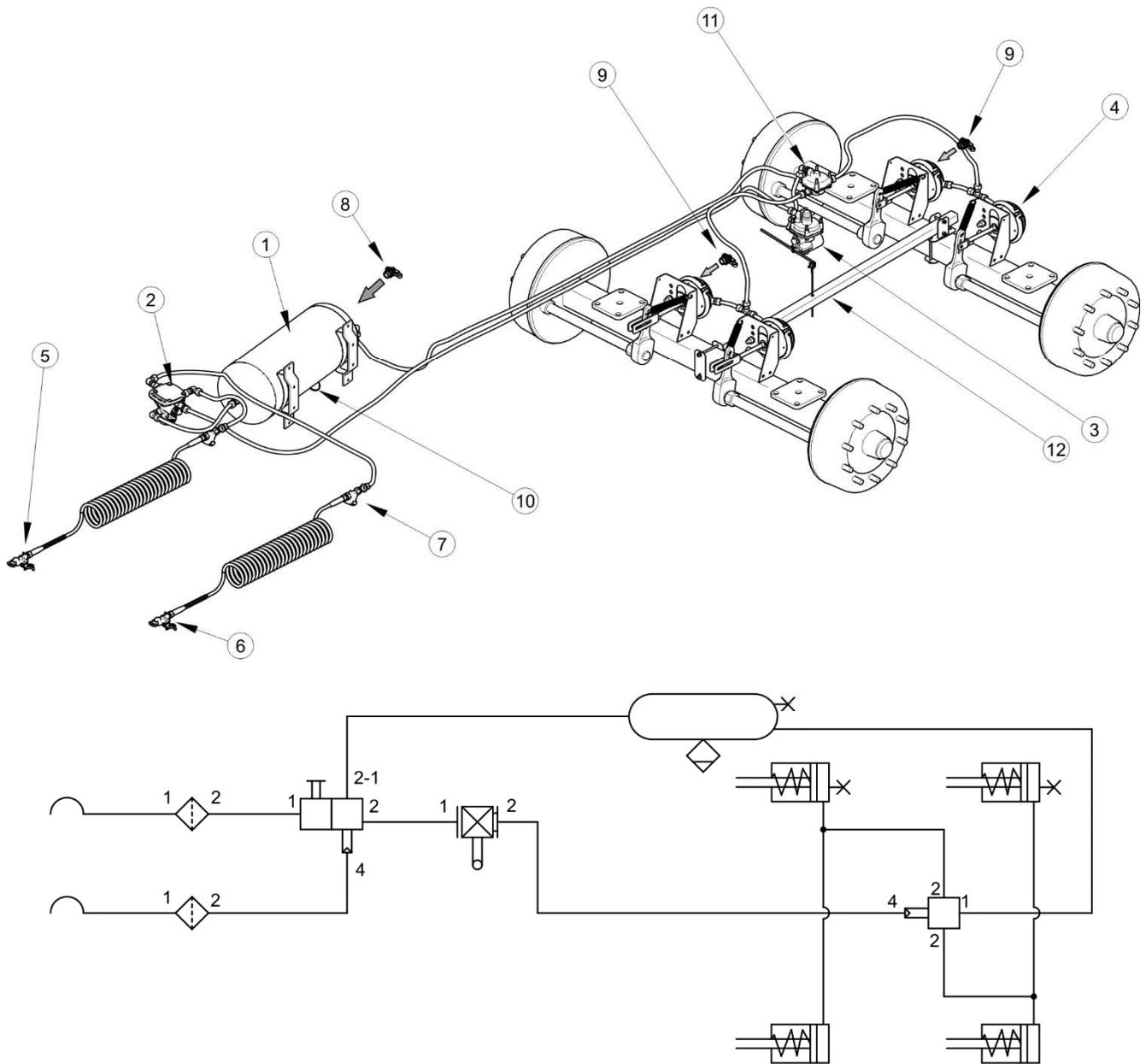

**FIG. 3.13 Design and system diagram of double line pneumatic brake with ALB automatic regulator**

(1) air tank, (2) control valve, (3) braking force regulator, (4) pneumatic ram cylinder, (5) line connector (red), (6) line connector (yellow), (7) air filter, (8) air tank control connector, (9) pneumatic ram cylinder control connector, (10) drain valve, (11) relay valve, (12) ALB beam

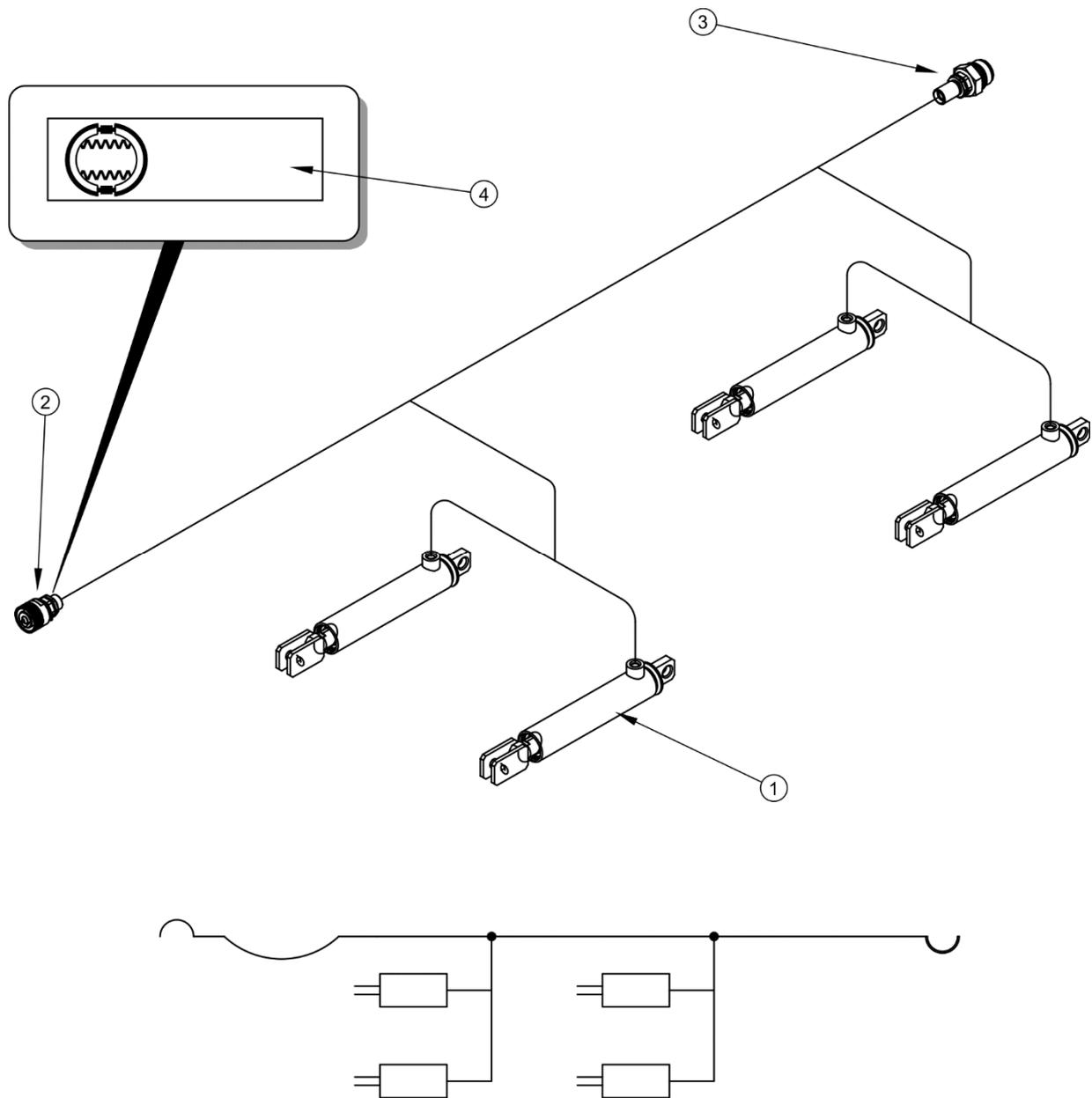

**FIG. 3.14 Design and diagram of hydraulic braking system**

*(1) hydraulic cylinder, (2) hydraulic quick coupler, (3) hydraulic socket, (4) information decal*

Three-step brake force regulator - figure (3.15), applied in pneumatic systems adjusts braking force depending on setting. Switching to a suitable working mode is done manually by machine operator using the lever (4) prior to moving off. Three working positions are available: A - "no load", B - "half load" and C - "full load".

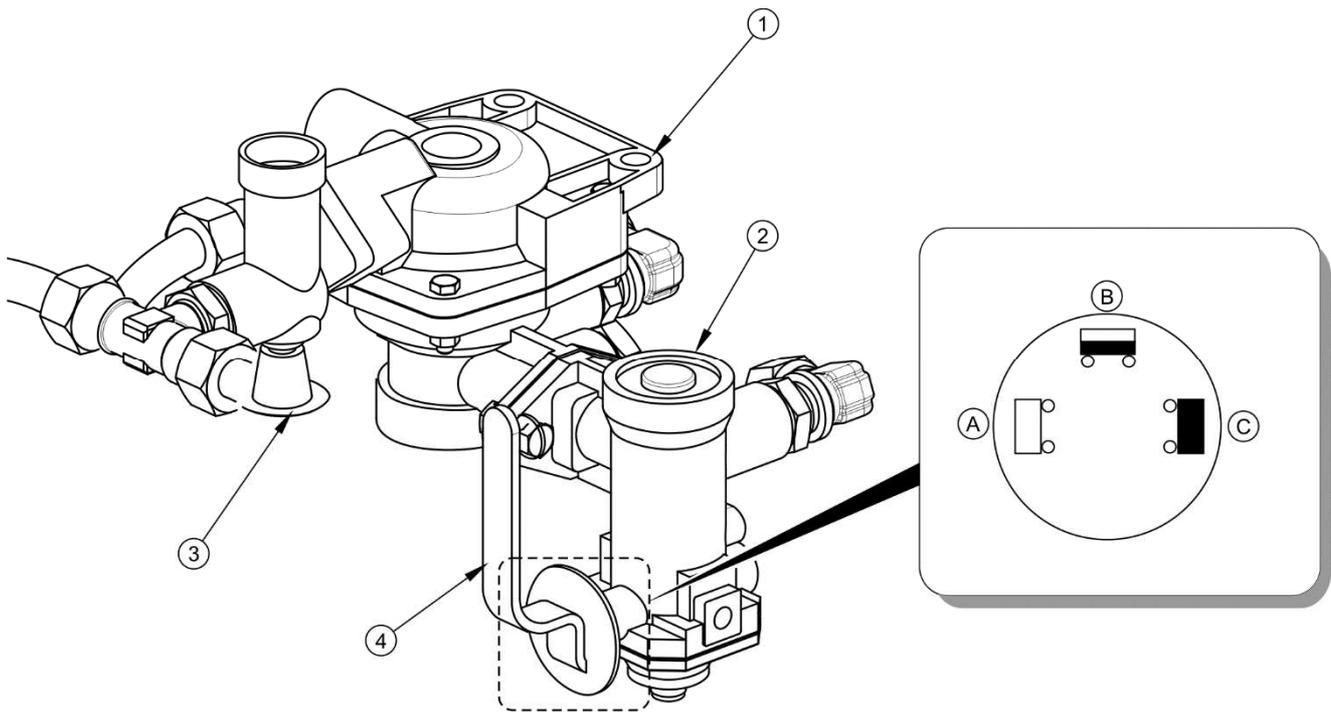
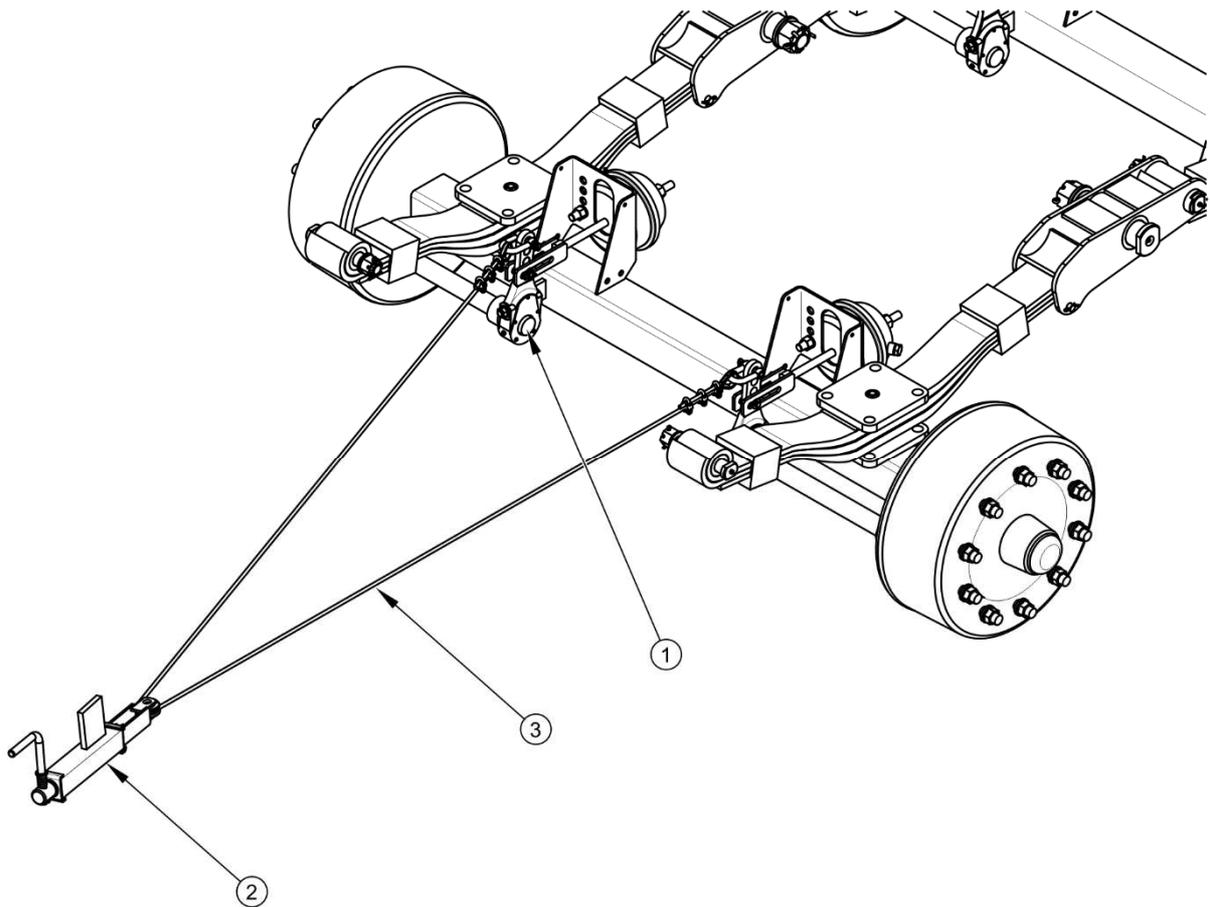

**FIG. 3.15 Control valve and brake force regulator**

(1) control valve, (2) brake force regulator, (3) trailer parking brake release button, (4) work selection regulator lever, (A) position "NO LOAD", (B) position "HALF LOAD", (C) position "FULL LOAD"

**3.2.11 PARKING BRAKE**

The parking brake is for immobilising manure spreader while standing motionless. System construction is shown in Figure (3.16). Brake crank mechanism (2) is welded to the left longitudinal member of the lower frame. Expander levers (1) of the front axle are connected to crank mechanism using cable (3) Tightening the cable causes tilting of the expander lever, which parts the jaws of the brake shoes immobilising the spreader.



**FIG. 3.16**      **Parking brake**

*(1) expander lever, (2) brake crank mechanism, (3) steel cable, (4) guide roller*

### **3.2.12 LIGHTING SYSTEM, WARNING ELEMENTS**

The manure spreader electrical system is designed for supply of 12 V DC. Connection of the manure spreader electrical system with the tractor should be made through an appropriate connection lead that is part of the machine's standard equipment.

As shown in Figure (3.17), (3.18), the manure spreader is equipped with reflectors for improved visibility on the road.

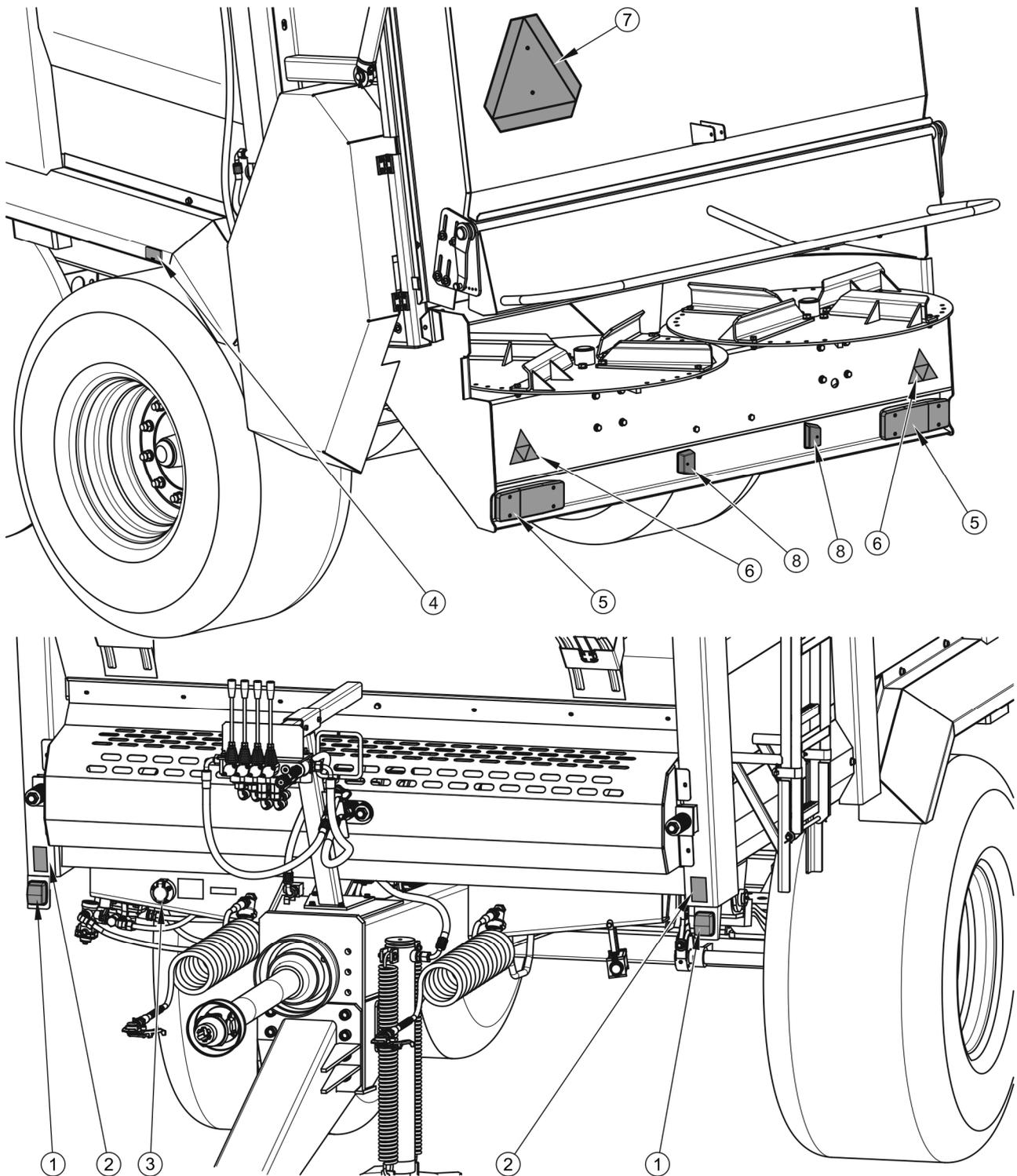

**FIG. 3.17** Positioning of warning signs and lights – version standard

(1) front parking light, (2) white reflector, (3) connection socket, (4) orange reflector, (5) rear lamp assembly, (6) reflective triangle, (7) slow-moving vehicle warning sign, (8) licence plate light

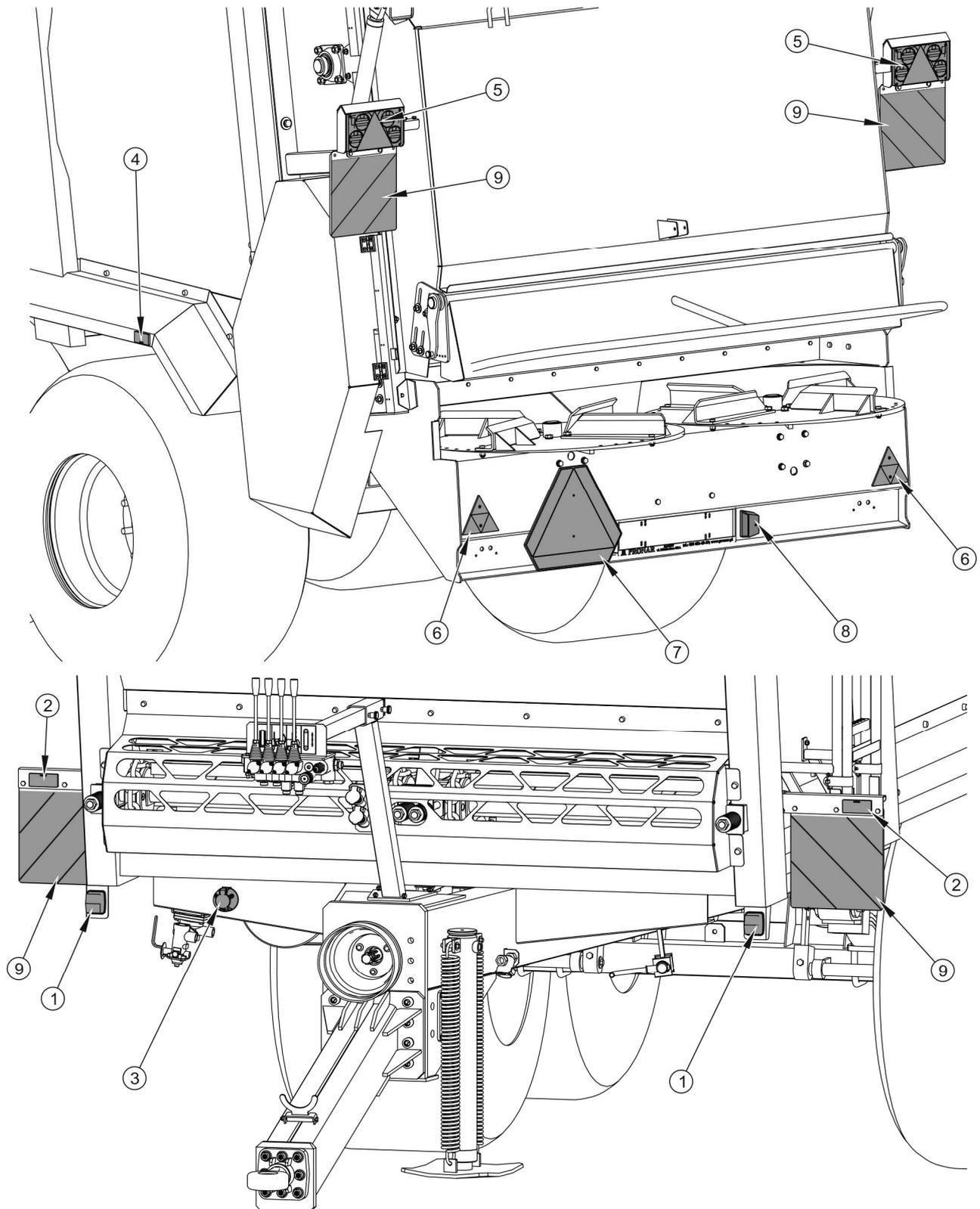

**FIG. 3.18 Positioning of warning signs and lights –version EU**

(1) front parking light, (2) white reflector, (3) connection socket, (4) orange reflector, (5) rear lamp assembly, (6) reflective triangle, (7) slow-moving vehicle warning sign, (8) licence plate light, (9) warning board

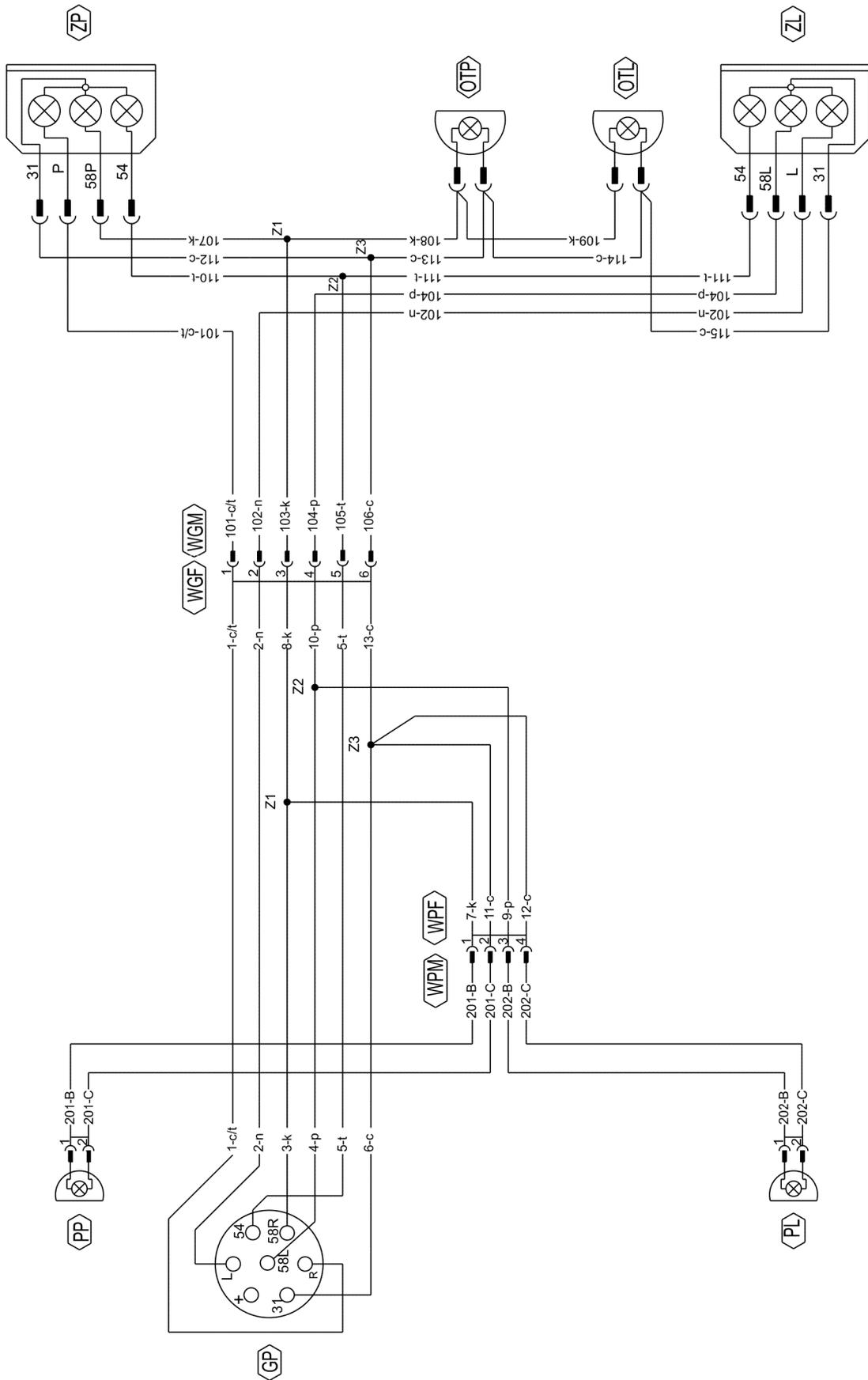

FIG. 3.19 Electrical system diagram

**TAB. 3.3 Line colour marking**

MARKING	COLOUR
C	Black
B	White
K	Red
N	Blue
P	Orange
T	Green
C/T	Black and green

**TAB. 3.4 List of electrical component markings**

SYMBOL	NAME
ZP	Rear right lamp assembly
ZL	Rear left lamp assembly
GP	Front seven pin socket
PP	Front right parking light
PL	Front left parking light
OTP	Right license plate light
OTL	Left license plate light

**TAB. 3.5 Socket connection marking GP**

MARKING	FUNCTION
31	Weight
+	Power supply +12V (not used)
L	Left indicator
54	STOP light
58L	Rear left parking light
58R	Rear right parking light
R	Right indicator



*SECTION*

**4**

---

**CORRECT USE**

## 4.1 PREPARING FOR WORK BEFORE FIRST USE

### 4.1.1 CHECKING THE MANURE SPREADER AFTER DELIVERY

The manufacturer guarantees that the manure spreader is fully operational and has been checked according to quality control procedures and is ready for use. This does not release the user from an obligation to check the machine's condition after delivery and before first use. The machine is delivered to the user completely assembled.

#### **DANGER**

Before proceeding to hitching to tractor and before first use of the manure spreader the user must carefully read this Operator's Manual and the Operator's Manual of PTO shaft attached to the machine and observe all recommendations.

Non-compliance with the safety rules of this Operator's Manual can be dangerous to the health and life of the operator and others.



The manure spreader must never be used by persons, who are not authorised to drive agricultural tractors, including children and people under the influence of alcohol or other drugs.

Careless and improper use and operation of the manure spreader, and non-compliance with the recommendations given in this operator's manual is dangerous to your health.

Before starting the machine, make sure that there are no bystanders in the danger zone.

The manure spreader may only be hitched to a tractor which has the appropriate hitch and required connection sockets for braking, hydraulic and electrical systems. Oil in the tractor external hydraulic system must have appropriate characteristics or must be mixable with the oil in the hydraulic system of the manure spreader.

Before connecting to tractor, machine operator must inspect the technical condition of the manure spreader, adapt it to his/her own needs and prepare it for test start-up. In order to do this:

- ➔ check completeness of machine,
- ➔ check condition of paint coatings, traces of corrosion or mechanical damage (crushing, piercing, bending or breaking of minor elements),
- ➔ check technical condition of protective shields and check if they are correctly installed,

- ➔ visually inspect the manure spreader individual components for mechanical damage resulting from incorrect loading, transport or unloading of the machine,
- ➔ check technical condition of the spreader lights and indicators,
- ➔ check technical condition of PTO shafts and their shields as well as completeness of these elements,
- ➔ check technical condition of hydraulic and pneumatic lines,
- ➔ check that there are no hydraulic oil leaks.

#### **4.1.2 PREPARING THE MANURE SPREADER FOR THE FIRST HITCH**

In preparation for the hitching of the spreader for the first time, check the type of the tractor system and possibly configure the spreader brake system. If the tractor is equipped with a single conduit brake system, the spreader's system (double conduit) must be configured for the tractor. In order to do this:

- ➔ remove the yellow spiral conduit (1) together with the connector,
- ➔ dismantle conduit (4), which connects filter (7) with control valve (3),
  - ⇒ on the control valve side, unscrew the conduit together with connector (5) and seal set (6),
- ➔ in place of the removed conduit plug the valve with the cap (8) and washers (10) that are supplied with the trailer,
- ➔ dismantle red connector that is screwed to the red spiral conduit and replace the red connector with black connector (9). Install washer (10).

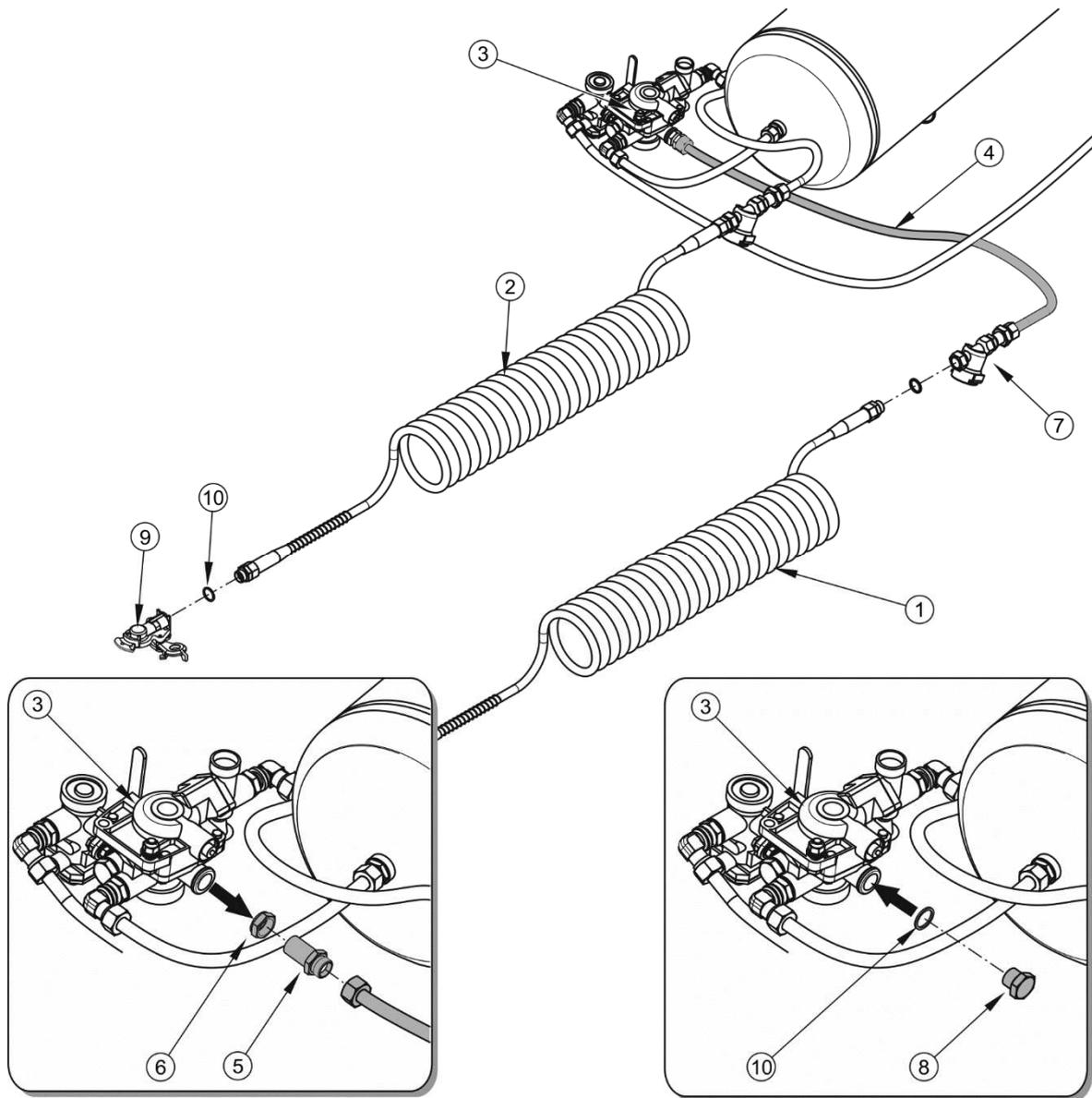

**FIG. 4.1 Reconfiguring the double conduit system for single conduit operation**

(1) yellow spiral conduit, (2) red spiral conduit, (3) control valve, (4) pneumatic conduit, (5) connector, (6) seal set, (7) conduit filter, (8) plug, (9) black conduit connector, (10) copper washer

Before connecting to tractor, machine operator must check the technical condition of the spreader and adapt it to his/her own needs. In order to do this:

- check all lubrication points, lubricate the machine elements as needed according to recommendations provided in section 5.6 "MANURE SPREADER LUBRICATION",
- adjust the height of the upper drawbar eye position (option) to the tractor hitch, a detailed description can be found in section 5.16,

- ➔ check if the nuts fixing the following components are properly tightened: (wheels, drawbar hitching eye, spreading mechanism),
- ➔ check oil level in the spreader unit transmission and in the feeding mechanism transmission,
- ➔ check tension of chain conveyor chain according to chapter 5.14,
- ➔ check technical condition of PTO shafts, their shields and securing chains,
- ➔ check the compliance of PTO parameters, termination type, speed,
- ➔ make sure that the attached PTO shaft may be connected to the tractor (PTO shaft should be suitable for the tractor – see the Operator's Manual of PTO shaft),
  - ⇒ check length of PTO shaft in the most favourable and difficult working conditions,
  - ⇒ check whether the PTO shaft pipes are sufficiently covered when the widest angle is set between the tractor and the machine,
  - ⇒ check whether the PTO shaft can be still slid when the smallest angle is set (while turning),
  - ⇒ check the PTO shaft length when driving up a hill (a steep slope).

### ATTENTION



Pipe profiles of the PTO shaft must overlap at least at 1/2 of the length in normal working conditions and at least at 1/3 of the length in all working conditions.

When adjusting the PTO shaft, follow the instructions presented in the Operator's Manual of the PTO shaft.

When the tractor with the manure spreader are turning or travelling on an uneven terrain, the PTO shaft may be damaged and/or destroyed if it is squeezed or disconnected as a result of its wrong adjustment.



### TIP

Adjustment of the PTO shaft applies only to a specific type of tractor. If the machine is connected to a different type of tractor, the adjustment procedure for this type of tractor should be possibly carried out.

### 4.1.3 TEST START

If all the above activities have been performed and there is no doubt as to the good technical condition of the spreader, the machine should be hitched to tractor according to instructions specified in section 4.3 „*HITCHING TO TRACTOR*”. Start tractor engine, check all systems and perform a test run of the manure spreader without load before beginning work. It is recommended that the inspection is conducted by two people, one of which should always remain in the tractor cab. Test start should be conducted according to the sequence shown below.

- ➔ Connect the manure spreader to appropriate hitch on agricultural tractor.
- ➔ Connect PTO shaft and secure it in a proper manner.
- ➔ Raise the parking stand.
- ➔ Connect brake, electrical and hydraulic system conduits.
- ➔ Check correct operation of lights and indicators.
- ➔ Start tractor.
- ➔ When moving off check if the main brakes operate correctly.
- ➔ Check if the chain conveyor operates correctly.
  - ⇒ If the hydraulic system is controlled from the tractor, start the chain conveyor using the appropriate manifold lever in the tractor cab. Set the conveyor speed by turning the knob of the flow regulator (item 1 - figure (3.3) installed on the outrigger in the front section of the manure spreader from position „0” to the maximum position „10” and check if the feed direction is correct. Forward or reverse direction of movement is selected using the appropriate selective control valve lever in the tractor cab. Check if conduits are connected in a correct manner and if flow regulator operates correctly.
  - ⇒ If the hydraulic system is controlled from the manure spreader, start the chain conveyor using the appropriate manifold lever installed on the outrigger of the manure spreader conduits (Figure (3.8)). Using the regulator knob, set the feed speed by shifting the knob from position „0” to the maximum position „8” and check if the feed direction is

correct. Forward or reverse direction of movement is selected using the appropriate selective control valve lever in the spreader. Check if conduits are connected in a correct manner and if flow regulator operates correctly.

- ➔ Actuate and check tailgate control system.
- ➔ Actuate and check slide gate control system.
- ➔ Start tractor PTO slowly (starting the drive of the spreader unit wormshafts and wide spread discs).
- ➔ Leave for several minutes working at low RPM, during which check:
  - ⇒ that there is no knocking or noise in the drive system, spreader unit and wide spread mechanism arising from grinding of metal elements,
  - ⇒ if spreader unit wormshafts and wide spread mechanism discs rotate smoothly and without resistance.
- ➔ Disconnect PTO drive, turn off tractor engine and unhitch the manure spreader from tractor.

## **DANGER**



**Before starting the tractor with the coupled machine, make sure that PTO drive is disconnected. Otherwise, the machine may be started in an uncontrolled manner.**

**Do NOT use PTO rotation speed other than 1,000 rpm. If PTO shaft works at a different speed, rotation speed of disintegrating drums and discs will be insufficient and the drive will be at the risk of damage.**

The manure spreader may be used only when all preparatory activities have been completed satisfactorily. If during manure spreader test start worrying symptoms occur such as:

- noise and abnormal sounds originating from the abrasion of moving elements of the manure spreader design,
- hydraulic oil leak,
- pressure drop in brake system,
- incorrect hydraulic system operation
- blocking of brake cylinders,

- other suspected faults

immediately cut off oil supply, disconnect tractor PTO drive and identify a fault. If a fault cannot be rectified or the repair could void the warranty, please contact the retailer or directly the manufacturer for additional clarifications or to perform the repair.

### ATTENTION



Check correctness of hydraulic connections. Replace line plugs possibly.

Non-adherence to the recommendations stated in the Operator's Manual or improper use of the manure spreader may cause damage to the machine.

The technical condition before starting the manure spreader must be no cause for concern.

## 4.2 TECHNICAL CONDITION INSPECTION

When preparing the manure spreader for operation check the following:

- ➔ technical condition of tyres and tyre pressure,
- ➔ tightening of major nut and bolt connections (wheels, drawbar hitching eye, spreading mechanism),
- ➔ operation of manure spreader lights and indicators,
- ➔ operation of manure spreader's brake system,
- ➔ correct operation of the hydraulic system,
- ➔ oil level in the lubrication system of the reduction gears according to chapter 5.5 „REDUCTION GEAR MAINTENANCE”,
- ➔ technical condition of PTO shafts, their shields and securing chains. after a stoppage, grease all the lubrication points according to the Operator's Manual of the PTO shaft,
- ➔ lubricate elements of the machine according to guidelines presented in section 5.6 „LUBRICATION OF MANURE SPREADER”, in compliance with lubrication schedule,

- ➔ floor conveyor tension and adjust if necessary – see chapter 5.12 „CHECKING AND ADJUSTING THE TENSION OF FLOOR CONVEYOR CHAIN”.

## **DANGER**



**Do NOT use a malfunctioning or incomplete spreader.**

**Careless and improper use and operation of the manure spreader, and non-compliance with the recommendations given in this operator's manual is dangerous to your health.**

**Prior to connecting individual system conduits, the user must carefully read the tractor Operator's Manual and observe all Manufacturer's recommendations.**

## **4.3 HITCHING TO TRACTOR**

Prior to attempting to hitch the manure spreader to tractor, make sure that the tractor is immobilised with parking brake. The manure spreader may be attached only to the tractor equipped with all necessary connections (electric, pneumatic and hydraulic connections) and the tractor hitch in accordance with the requirements of the manure spreader Manufacturer.

## **DANGER**



**When hitching, there must be nobody between the manure spreader and the tractor. When hitching the machine, tractor driver must exercise caution and make sure that nobody is present in the hazard zone.**

**Make sure that there is nothing and nobody inside the load box.**

**Be especially careful when hitching the machine to the tractor.**

**When connecting the hydraulic conduits to the tractor, make sure that the tractor and manure spreader hydraulic system are not under pressure.**

In order to hitch the spreader to tractor, proceed as follows

- ➔ Immobilise the manure spreader with parking brake.
- ➔ Position agricultural tractor directly in front of drawbar eye.
- ➔ Reverse tractor and connect the conduit marked with decal (28)– table (2.1) (straight hydraulic support). If the spreader is equipped with the hydraulic system controlled from the manure spreader, connect two hydraulic conduits marked with decals (23) – table (2.1) in the form of arrows indicating the correct direction of hydraulic oil flow to the manifold - figure (3.8), next, set the

- outrigger in such a manner as to enable controlling the manure spreader operation from the tractor cab through the opened rear window.
- ➔ Open cut off valve (3) – figure (3.4) located on the manure spreader frame and set the drawbar eye height, using the parking stand, so that it is possible to connect the machines.
  - ➔ Reverse tractor, hitch manure spreader, check coupling lock protecting machine against accidental unhitching.
    - ⇒ If the agricultural tractor is equipped with an automatic coupler, ensure that the hitching operation is completed and that drawbar eye is secured.
  - ➔ Raise the parking stand to a required height.
    - ⇒ After coupling the machines, the parking stand must be raised so as to not hit the ground or any other obstacle.
    - ⇒ Secure the parking stand against lowering using a valve.
  - ➔ Turn off tractor engine. Ensure that unauthorised persons do not have access to the tractor cab.
  - ➔ Connect pneumatic system conduits (applies to double conduit systems):
    - ⇒ Connect pneumatic conduit marked yellow with yellow socket in tractor.
    - ⇒ Connect pneumatic conduit marked red with red socket in tractor.
  - ➔ Connect pneumatic system conduit (applies to single conduit system).
    - ⇒ Connect pneumatic conduit marked black with black socket in tractor.
  - ➔ Connect hydraulic brake system (applies to spreader version with hydraulic brake).
    - ⇒ Hydraulic brake system conduit is marked with information decal (24) – table (2.1).
  - ➔ Connect hydraulic conduits of the floor conveyor movement system to the tractor (refers to the system controlled from the tractor).

- ⇒ Conveyor connection conduits are marked with decals in the form of arrows indicating the direction of hydraulic oil flow (item 23 - table (2.1)).
- ➔ Connect hydraulic conduit of the tailgate control system to the tractor (refers to the system controlled from the tractor).
  - ⇒ The tailgate control conduit is marked with decal (item 25– table (2.1)).
- ➔ Connect hydraulic conduits of the slide gate control system to the tractor (refers to the system controlled from the tractor).
  - ⇒ The slide gate control conduits are marked with decals (item 26 and 27 – table (2.1)).
- ➔ Connect the main wiring to power the electric lighting.

### ATTENTION



When connecting the control conduits of individual hydraulic circuits, be careful not to make wrong connections of conduit pairs. Conduits are identified with information decals.

- ➔ Connect PTO shaft to tractor. Ensure that the ends of PTO shaft hitch are well fitted and the hitch is properly secured.
- ➔ Release parking handbrake by turning the crank of the parking brake's mechanism.

### ATTENTION



Prior to attaching the manure spreader, check the technical condition of the manure spreader's and tractor's hitch system and connection elements of the hydraulic, electrical and pneumatic systems.

The hydraulic oils in the tractor and the manure spreader must be mixable.

Be especially careful when hitching the machine to tractor.

When hitching is completed, secure the electrical leads and hydraulic and braking system lines in such a way that they do not become entangled in tractor's moving parts and are not at the risk of breaking or severed when making turns.

The parking stand must be maximally raised and secured using a cut-off valve during the manure spreader operation or travel.

## 4.4 LOADING THE LOAD BOX

Before loading, check that the load box slide gate is closed. Before loading, position the manure spreader connected properly with the tractor on level and stable surface. Immobilise both machines with parking brake.

When loading the manure spreader, it is recommended to use an appropriate loader or conveyor. If loading is carried out by a loader with bucket forks, the width of bucket forks should not exceed the load box length. Bucket forks should be emptied by tilting when positioned not higher than 1 meter above the load box height. Manure should not be artificially compacted. When loading, pay attention not to overload the manure spreader. Height of loaded manure must not exceed the height of the spreader unit mechanism.

In order to ensure optimum spreading, efforts should be made to evenly distribute the load in the load box. Manure should be loaded starting from the rear and moving towards the front of the manure spreader. Such loading method has positive impact on quality of manure spreading.

Due to the various density of fertilizing materials, using the total load box capacity may cause exceeding permissible carrying capacity of the manure spreader. Guideline specific weight of selected materials is shown in table (4.1). Take care not to overload the manure spreader.

**TAB. 4.1 Guideline weights by volume of selected loads**

TYPE OF MATERIAL	VOLUME WEIGHT KG / M <sup>3</sup>
<b>Organic fertilisers:</b>	
old manure	700 - 800
mature manure	800 - 900
fresh manure	700 - 750
compost	950 – 1 100

Regardless of the type of load carried, the user is obliged to secure it in such a manner that the load is unable to spread and cause contamination of the road. If this is impossible, do NOT transport this type of load.

**ATTENTION**

Do NOT exceed permissible load weight of manure spreader because this may cause danger to road traffic and cause damage to the machine.

Unevenly loaded manure is spread unevenly in the field.

Before moving off, check that the load box slide gate is closed and the tailgate is lowered.

Height of loaded manure must not exceed the height of the spreader unit mechanism.

## 4.5 SPREADING AND ADJUSTING FERTILIZER DOSE

### 4.5.1 ADJUSTING FERTILIZER DOSE

Amount of material spread on a specific field area depends on the following factors:

- type of material spread,
- chain conveyor speed,
- setting of blades on the wide spread mechanism discs,
- travel speed.

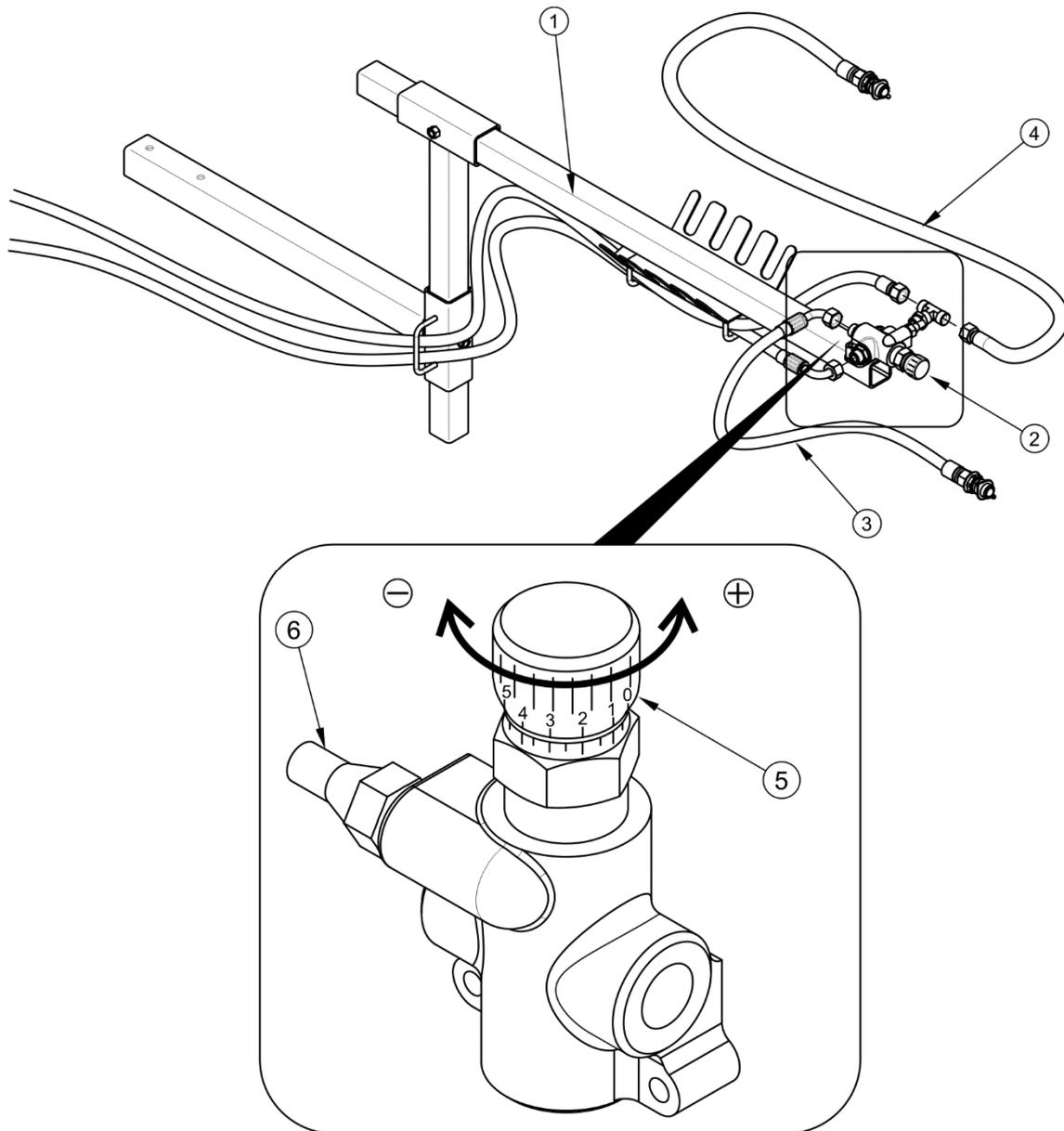

**FIG. 4.2 Adjustment of chain conveyor speed (controlled from the tractor)**

(1) conduit bracket, (2) flow regulator, (3) supply conduit, (4) return conduit, (5) adjusting knob with scale from 0 to 10, (6) two-stage overflow valve

Proper fertilizer dose is set by means of chain conveyor. If the manure spreader is equipped with the hydraulic system controlled from the tractor, set the chain conveyor speed using knob (5) on flow regulator (2) located on cable bracket (1) - figure (4.2).

- The chain conveyor speed is reduced by turning the knob clockwise to "0" setting.

- The chain conveyor speed is increased by turning the knob counterclockwise, maximally to "10" setting.

### TIP



When the manure spreader travel speed is high and the conveyor speed is low, a small spreading dose is obtained.

When the manure spreader travel speed is low and the conveyor speed is high, a large spreading dose is obtained.

Various characteristics of manure (e.g. dampness, specific weight, granulation), influence of wind determine the spreading parameters. That is why it is impossible to predetermine the settings of the manure spreader's adjusting devices. In order to determine the settings, preset the machine, make a test and correct the settings, if necessary.

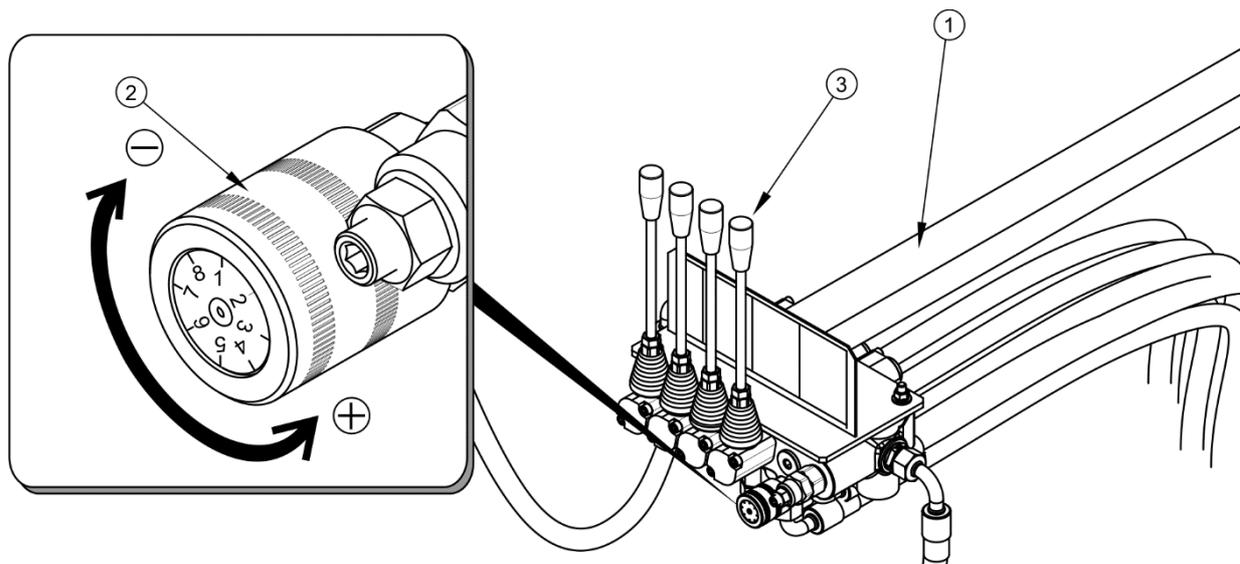

**FIG. 4.3 Adjustment of chain conveyor speed (controlled from the manure spreader)**

(1) conduit bracket, (2) flow regulator knob, (3) manifold lever

If the manure spreader is equipped with the hydraulic system controlled by the manifold installed on the outrigger (1), set the chain conveyor speed using flow regulator knob (2) located on the manifold. The conveyor movement is activated and the conveyor movement direction is changed using manifold lever (3) - figure (4.3).

- The chain conveyor speed is reduced by turning the knob clockwise to "1" setting.
- The chain conveyor speed is increased by turning the knob counterclockwise, maximally to "8" setting.

### ATTENTION



Proper operating range of the regulator starts from the second rotation of the knob. Oil flow, hydraulic motor rotation and chain conveyor speed are increased by turning the knob anticlockwise. The scale of the knob is from 1 to 8 (figure (4.3)). The maximum speed of the conveyor is achieved when the knob is turned until resistance is felt.

#### 4.5.2 ADJUSTMENT OF SPREADING WIDTH

Before manure spreading, carry out spreading test because manure may have various characteristics. Spreading width differs depending on type of material spread (e.g. it is smaller for dry manure and greater for wet manure). In order to enable matching of spreading width to type of material spread, there are 6 adjustment openings for each blade on a disc.

Spreading width is adjusted by changing the position of blades (5) on spreading discs (1) and (2). Spreading width is decreased by shifting the blades in the direction of spreading disc rotation.

Changing the position of blades on the spreading disc is conducted as follows:

- ➔ Loosen bolt (6).
- ➔ Unscrew nut (7) underneath the disc and take out bolt (8),
- ➔ Shift the blade in such position as to install bolt (2) in a proper hole on the disc.
- ➔ Lock spreading blade in a selected position by means of nut (7) and tighten bolt (6).
- ➔ Repeat the procedure for each blade to ensure that all blades are set in the same way.

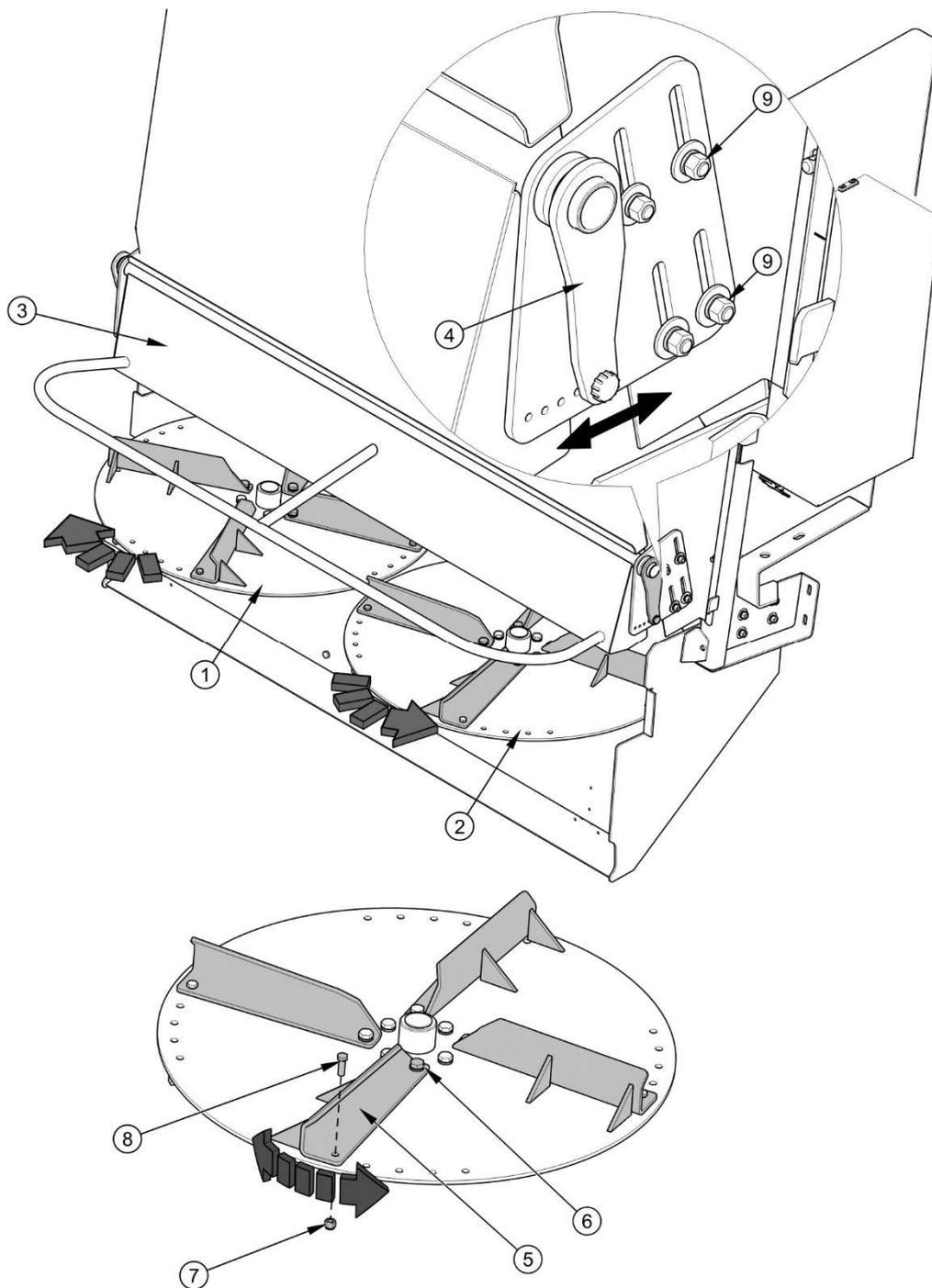

**FIG. 4.4**      **Adjustment of spreading width**

(1) left disc, (2) right disc, (3) adjusting shield, (4) adjusting lever, (5) blade, (6) M16x40 bolt, (7) M12 self locking nut, (8) M12x30 bolt, (9) M12 nut

To improve distribution, depending on material spread, the height of shield (3) can be adjusted. In order to make the adjustment, loosen nuts (9), raise or lower the shield and lock it again with nuts. Inclination angle is adjusted using two levers (4) located on both sides of

the shield. Shift the levers towards the rear of the manure spreader in order to increase flow capacity between the shield and spreading discs and shift the levers in the opposite direction to decrease the flow capacity.



### TIP

When spreading manure containing long straw, it is recommended that the shield is raised in order to increase flow capacity and prevent blocking of manure on spreading discs.



### attention

When spreading manure, **DO NOT** set the rear adjusting shield forward. The shield set in this way may cause clogging of the space under the tailgate and blocking of disintegrating drums and consequently, it may cause damage to overload coupling.

Regularly check degree of wear of blades and replace them if necessary.

## 4.5.3 SPREADING MANURE IN THE FIELD

Before commencing work check again the technical condition of hydraulic connections and safety guards installed on the manure spreader and PTO shaft. Check if net protection is installed on the front wall. The net protection protects the operator against injury and the tractor against damage by thrown elements, for example, stones.

### DANGER



Operation of the manure spreader without safety guards or with damaged PTO shaft creates a direct threat to health and life of the machine operators.

There must be no bystanders within the machine working zone.

Keep a safe distance from electric power lines.

The manure spreader may be operated only with the net protection installed on the front wall.

**Do NOT** spread manure near grazing animals.

The manure spreader starting procedure in order to spread manure in the field.

- ➔ Set the tractor PTO rotation speed proper for the manure spreader.
- ➔ Start the spreader unit by engaging drive to tractor PTO.
  - ⇒ Start tractor PTO slowly in order to avoid damage to PTO shaft.

**TIP**

In order to obtain uniform spreading in the beginning of operation, increase PTO rotation speed to maximum 1000 rpm and engage the chain conveyor when the manure spreader is still motionless. Spread manure while the manure spreader is motionless until a sufficient amount of manure is delivered to the spreader unit wormshafts. Then, engage appropriate tractor gear and start working.

In order to ensure optimum spreading, maintain PTO rotation speed at the level of 1,000 rpm.

**DANGER**

Do NOT use PTO rotation speed other than 1,000 rpm. If PTO shaft works at a different speed, rotation speed of disintegrating wormshafts will be insufficient and the drive will be at the risk of damage.

- ➔ Raise the load box slide gate
  - ➔ Engage the chain conveyor.
  - ➔ Engage appropriate tractor gear and start working.
- ⇒ Disengage PTO when making turns during operation. Protection of PTO shaft and uniform spreading are ensured in this way.

**ATTENTION**

Do NOT use another manure spreader starting procedure.

The feeding mechanism may be started only if the slide gate is raised.

The load can be moved forward only in exceptional situations such as in the case of blocking of disintegrating drums or when the tractor rear wheels lose grip. When moving the load forwards, the load must not touch the front wall because the load box or drive transmission system may be damaged.

Before turning and during transport the tractor PTO drive should be disconnected.

## 4.6 SPREADING MECHANISM CLOGGING

If the spreading mechanism (spreader unit) is clogged during spreading, the clogging elements can be removed by moving the floor conveyor towards the front wall. If the spreader unit is still clogged, disengage PTO drive and chain conveyor and raise the tailgate. Switch off tractor engine, disconnect PTO shaft and lock the tailgate using a cut-off valve and proper

support. Remove the items blocking the manure spreader using the appropriate tool. Remove strings from manure, if they occur. Otherwise, strings can deteriorate quality of manure spreading. Entwined strings should be removed using a sharp tool.

### ATTENTION

When the load box is loaded, direction of the feeding mechanism movement may be reversed only for a short time.

During maintenance with the tailgate raised, protect it from falling down by closing the cut-off valve. It is also recommended that the tailgate is protected using a suitable mechanical support which is durable and stably mounted. The mechanical support should be placed between tailgate and floor conveyor strip.



Take care not to lower or rise the tailgate when it is locked using a cut-off valve. Otherwise, hydraulic cylinders and/or tailgate may be damaged.

During work use the proper, close-fitting protective clothing, gloves and appropriate tools.

Servicing and repair work should be carried out in line with the general principles of workplace health and safety. In the event of injury, the wound must be immediately cleaned and disinfected. In the event of more serious injuries, seek a doctor's advice.

## 4.7 UNHITCHING FROM TRACTOR

In order to disconnect the manure spreader from the tractor, proceed as follows:

- ➔ Once tractor is stopped, immobilise the spreader using parking brake.
- ➔ Place chocks under manure spreader wheel.
  - ⇒ Wheel chocks must be so placed that one is in front of the wheel and the second is behind the wheel.
- ➔ Using the support, set the machine on the surface, at a proper height.
- ➔ Reduce residual pressure in the hydraulic system by moving the appropriate control lever of the tractor's hydraulic circuit.
- ➔ Turn off tractor engine. Ensure that unauthorised persons do not have access to the tractor cab.
- ➔ Disconnect electric lead.
- ➔ Lock the cut-off valve of parking stand.

- ➔ Disconnect the hydraulic system conduits and place them in appropriate sockets. Protect plugs of these conduits against soiling using protective caps.
- ➔ Disconnect pneumatic system conduits (applies to double conduit systems):
  - ⇒ Disconnect pneumatic conduit marked red.
  - ⇒ Disconnect pneumatic conduit marked yellow.
- ➔ Disconnect pneumatic system conduit (applies to single conduit system).
  - ⇒ Disconnect pneumatic conduit marked black.
- ➔ Protect conduit ends with covers. Place conduit plugs in appropriate locations.
- ➔ Disconnect PTO shaft and place it on PTO shaft bracket. If the machine will not be used for a long time, disconnect PTO shaft completely.
- ➔ Disconnect manure spreader drawbar from the tractor's hitch and move the tractor forward.

### ATTENTION



**Exercise caution when disconnecting the manure spreader from the tractor. Ensure good visibility. Unless it is necessary, do not go between tractor and manure spreader.**

**The manure spreader disconnected from the tractor must be immobilised with the parking brake. If the manure spreader is positioned on a slope or elevation it shall be additionally secured against moving by placing chocks or other objects without sharp edges under the manure spreader's wheels.**

**Before disconnecting lines, drawbar eye and PTO shaft, close tractor cab and secure it against access by unauthorised persons. Turn off tractor engine.**

**Do NOT park a loaded manure spreader, which is disconnected from the tractor and resting on the parking stand.**

## 4.8 PROPER USE AND MAINTENANCE OF TYRES

- When working with tyres, the manure spreader should be secured against rolling by placing chocks under the wheels. Wheels can be taken off only when the manure spreader is not loaded.
- Repair work on the wheels or tyres should be carried out by persons trained and entitled to do so. This work should be carried out using appropriate tools.

- 
- Inspect tightness of nuts after first use of the manure spreader, after first travel under load and then every 6 months of use or every 25,000 km. In the event of intensive work, check the nut tightening at least every 10,000 km. The inspection should be repeated individually if a wheel has been removed from the wheel axle.
  - Regularly check and maintain correct pressure in tyres according to Operator's Manual (especially if manure spreader is not used for a longer period).
  - Pressure and tyres should be also checked during the whole day of intensive work. Please note that higher temperatures could raise tyre pressure by as much as 1 bar. At high temperatures and pressure, reduce load or speed.
  - Do not release air from warm tyres to adjust the pressure or the tyres will be underinflated when temperatures return to normal.
  - Tyre valves should be protected with the appropriate caps to avoid soiling.
  - Do not exceed the manure spreader's maximum design speed.
  - When machine is operated all day, check temperature of tyres.
  - Adhere to 30 minutes rest for cooling tyres after driving 75 km or after 150 minutes continuous travel depending on which occurs first.
  - Avoid potholes, sudden manoeuvres or high speeds when turning.

***SECTION***

**5**

---

**MAINTENANCE**

## 5.1 PRELIMINARY INFORMATION

When using the manure spreader, regular inspections of its technical condition are essential and the performance of maintenance procedures, which keep the machine in good technical condition. In connection with this the user of the manure spreader is obliged to perform all the maintenance and adjustment procedures defined by the Manufacturer.

Repairs during the warranty period may only be performed by authorised service points.

Detailed procedures and extent of activities which the user may perform by himself are described in this section. In the event of unauthorised repairs, changes to factory settings and other actions, which are not regarded as possible for the manure spreader operator to perform, the user shall invalidate the warranty.

## 5.2 SERVICING BRAKES AND AXLES

### 5.2.1 PRELIMINARY INFORMATION

Work connected with the repair, change or regeneration of axle and brakes elements should be entrusted to specialist establishments, having the appropriate technology and qualifications for this type of work.

The responsibilities of the user are limited to:

- initial inspection of axle brakes,
- check brake shoe linings for wear,
- inspection and adjustment of loose play of axle bearings,
- mounting and dismounting wheel, inspection of wheel tightening,
- checking air pressure, evaluating technical condition of wheels and tyres,
- mechanical brakes adjustment,
- Replacing the parking brake cable and tension adjustment

Procedures connected with:

- changing grease in axle bearings,
- changing bearings, hub seals,

- changing brake linings, repairing brake,

may be performed by specialist workshops.



## **DANGER**

**Do NOT use the manure spreader when brake system is unreliable.**

### **5.2.2 INITIAL INSPECTION OF AXLE BRAKES**

After purchasing manure spreader, the user is responsible for general checking of brake system of manure spreader axles.

#### **Inspection procedures**

- ➔ Hitch manure spreader to tractor and place chocks under manure spreader wheel.
- ➔ Check means of securing cylinder and return springs.
- ➔ Engage and release in turn the main brake and then the spreader parking brake.
  - ⇒ Main brake and parking brake should be engaged and released without great resistance and severity.
- ➔ Check cylinder movement and correct return of piston to start position.
  - ⇒ The help of a second person is required, who shall engage manure spreader brake.
- ➔ Check if axle elements are in place, (cotter pins in castellated nuts, expansion rings etc.).
- ➔ Check hydraulic cylinders or pneumatic cylinders for tightness - compare section 5.3.2.



#### **Initial inspection of axle brakes must be conducted:**

- after the first use of the manure spreader,
- after first travel with load.

### 5.2.3 CHECK BRAKE SHOE LININGS FOR WEAR

Manure spreader brake shoes should be replaced when the brake lining thickness is less than the minimum specified by the manufacturer.



**TIP**

Minimum thickness of brake shoe linings is 5 mm.

Check brake shoe linings for wear through the inspection opening (2) – see Figure (5.1).



**Check brake shoe linings for wear:**

- every 3 months,
- if brakes overheat,
- if brake cylinder piston stroke is significantly longer,
- if there are unusual noises from the drum of wheel axle.

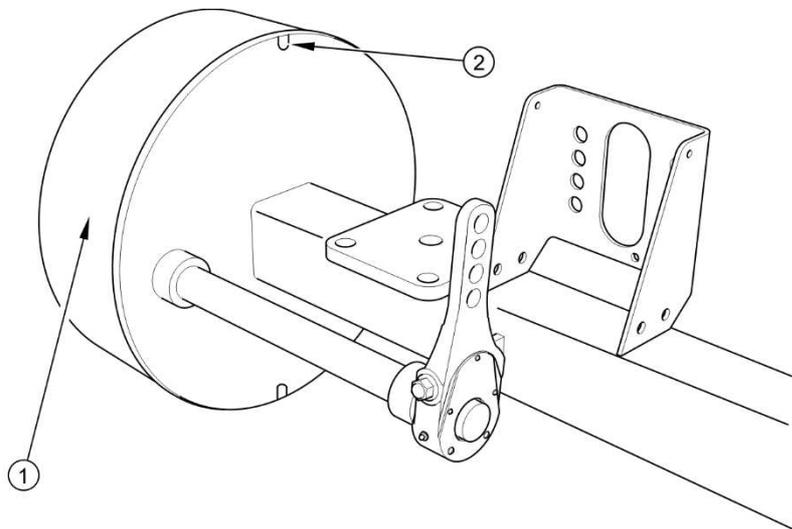

**FIG. 5.1**      **Checking brake shoe linings**

(1) wheel axle drum, (2) brake shoe linings for wear inspection opening

### 5.2.4 CHECK WHEEL AXLE BEARINGS FOR LOOSENESS

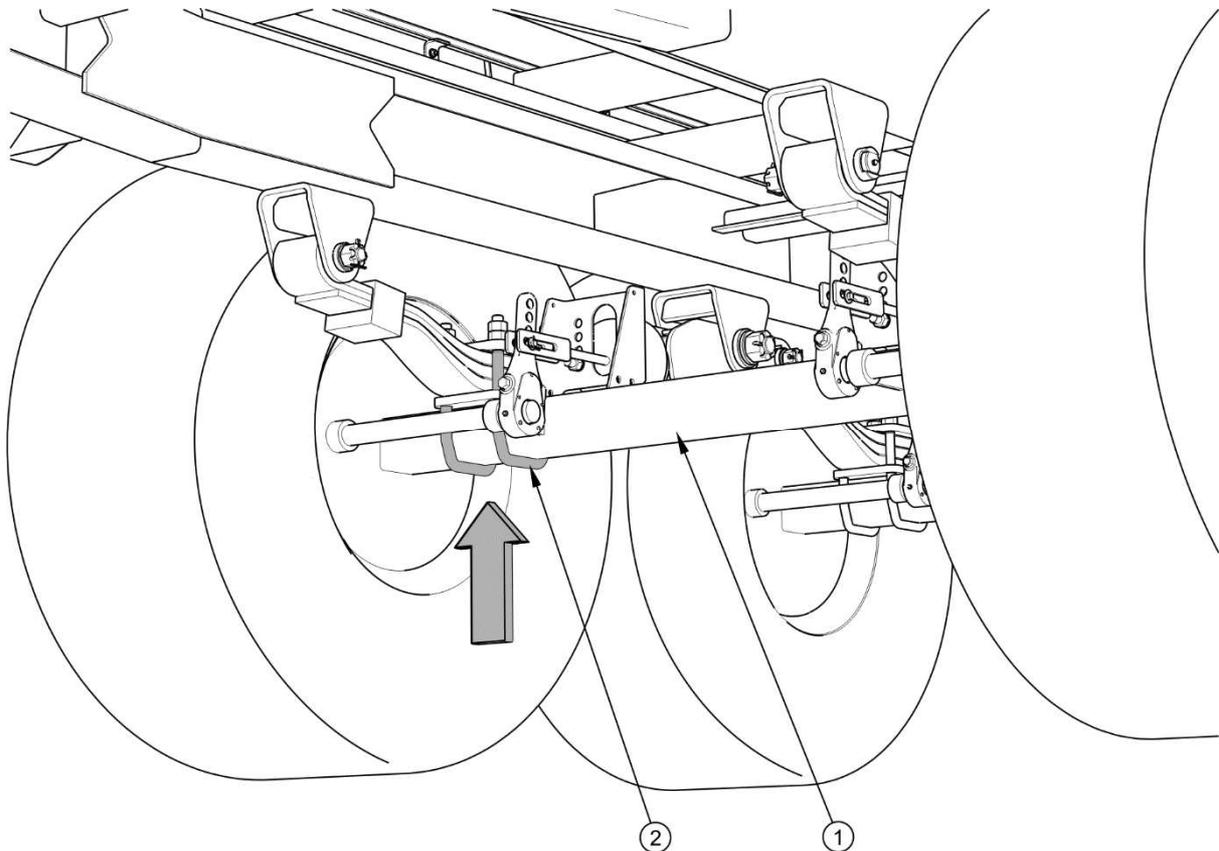

**FIG. 5.2** Lifting jack support point

(1) wheel axle, (2) U bolt

#### Preparation procedures

- ➔ Hitch manure spreader to tractor, immobilise tractor with parking brake.
- ➔ Park tractor and manure spreader on hard level ground.
  - ⇒ Tractor must be placed to drive forward.
- ➔ Place the wheel chocks under the manure spreader's wheel opposite to the lifted wheel. Ensure that manure spreader shall not move during inspection.
- ➔ Raise the wheel (opposite to the side where chocks are placed).
  - ⇒ The lifting jack should be placed under the axle between U bolts (2) - figure (5.2) securing axle (1) to shock absorber leaf springs, or as near as possible to leaf spring mounting. Recommended fulcrum is marked

with an arrow. Lifting jack must be suited to weight of manure spreader.

### Checking slackness of wheel axle bearings

- ➔ Turning the wheel slowly in both directions check that movement is smooth and that the wheel rotates without excessive resistance.
- ➔ Turn the wheel so that it rotates very quickly, check that the bearing does not make any unusual sounds.
- ➔ Turning the wheel try to detect looseness.
  - ⇒ You may use a lever placed under the wheel supporting the other end on the floor.
- ➔ Repeat procedure to each wheel individually, remembering that the jack must be on the side opposite to the chocks.



#### Check wheel axle bearings for play:

- after travelling the first 1,000 km,
- before intensive use of manure spreader,
- every six months use or every 25,000 km.

If play is felt, adjust bearing. Unusual sounds coming from bearing may be symptoms of excess wear, dirt or damage. In such an event the bearing, together with sealing ring, should be replaced with new parts, or cleaned and greased again. During inspection of bearings ensure that possibly detected looseness comes from the bearing and not from the suspension system (e.g. looseness of leaf spring pins etc.).



#### TIP

If hub cover is damaged or missing, contamination and dampness enter the hub, which causes significantly faster wear of bearing and hub seals.

Bearing life is dependent on working conditions of manure spreader, loading, speed of travel and lubrication conditions.

Check condition of hub cover, if necessary replace with new cover. Inspection of bearing looseness may only be conducted, when the manure spreader is hitched to a tractor, and the load box is empty.

## **DANGER**



Before commencing work the user must read the instructions for lifting and adhere to the manufacturer's instructions.

The lifting jack must be stably supported by the ground and so must the axle.

Ensure that manure spreader shall not move during inspection of bearing looseness of axles.

### **5.2.5 ADJUSTMENT OF PLAY OF WHEEL AXLE BEARINGS**

#### **Preparation procedures**

- ➔ Prepare tractor and manure spreader for adjustment procedures according to description provided in section 5.2.4.

#### **Adjustment of road wheel axle bearings**

- ➔ Take off hub cover (1) - figure (5.3).
- ➔ Take out split cotter pin (3) securing castellated nut (2).
- ➔ Tighten castellated nut in order to eliminate looseness.
  - ⇒ Wheel should rotate with insignificant resistance.
- ➔ Unscrew nut (not less than 1/3 rotation) to cover the nearest thread groove with alignment to opening in wheel stub axle. Wheel should rotate with insignificant resistance.
  - ⇒ Nut may not be excessively tightened. Do not apply excessive pressure because working conditions of the bearings may deteriorate.
- ➔ Secure castellated nut with cotter pin and mount hub cap.
- ➔ Delicately tap hub cap with rubber or wooden hammer.

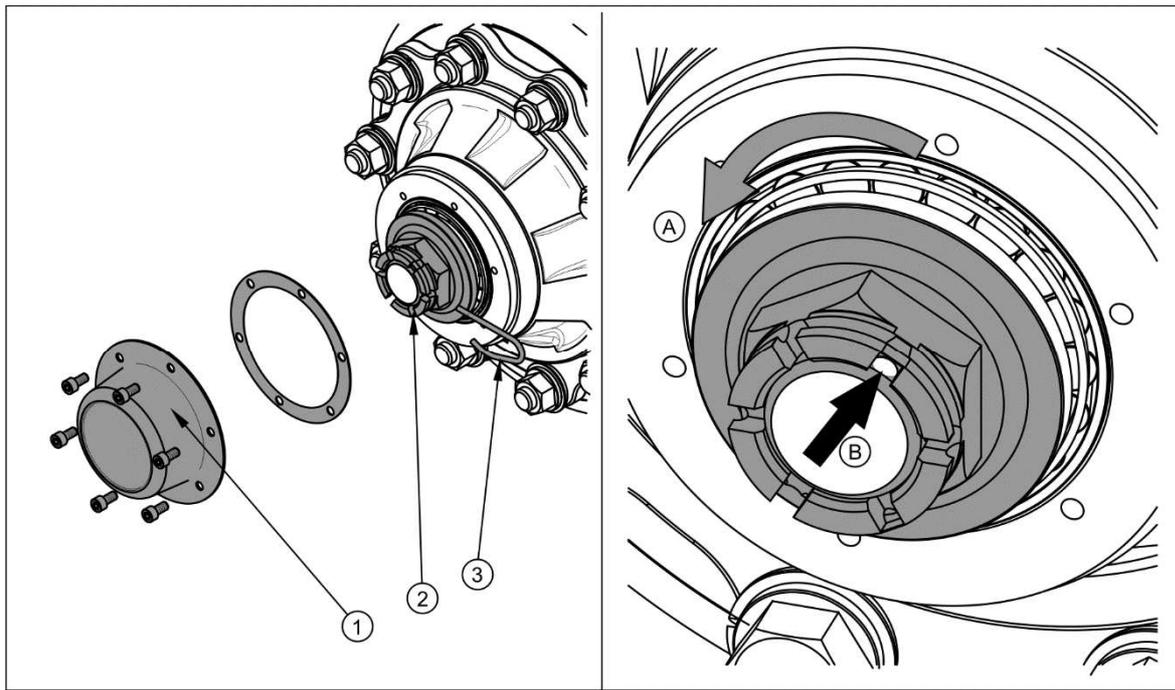

**FIG. 5.3 Adjustment of road wheel axle bearings**

(1) hub cover, (2) castellated nut, (3) securing split cotter pin

The wheel should turn smoothly without stiffness or detectable resistance not originating from abrasion of brake shoes in brake drum. Adjustment of bearing looseness may only be conducted, when the manure spreader is hitched to a tractor, and the load box is empty.



### TIP

If the wheel is dismantled, bearing looseness is easy to check and adjust.

## 5.2.6 MOUNTING AND DISMOUNTING WHEEL, INSPECTION OF WHEEL NUT TIGHTENING

### Wheel removal

- ➔ Immobilise the manure spreader with parking brake.
- ➔ Place the wheel chocks under the wheel opposite to the dismantled wheel.
- ➔ Ensure that the manure spreader is properly secured and shall not move during wheel dismantling.

- ➔ Loosen wheel nuts according to sequence given in figure (5.4).
- ➔ Place a lift and raise the manure spreader to a sufficient height so that the wheel to be replaced does not touch the ground.
- ➔ Dismount wheel.

### Wheel installation

- ➔ Clean axle pins and nuts of dirt contamination.
  - ⇒ Do not grease thread of nuts and pins.
- ➔ Check condition of pins and nuts, if necessary replace.
- ➔ Place wheel on hub, tighten nuts so that wheel rim tightly fits the hub.
- ➔ Lower the manure spreader, tighten nuts according to recommended torque and given sequence.



#### TIP

Wheel nuts should be tightened using a torque of 450 Nm - nuts M22x1.5.

### Tightening nuts

Nuts should be tightened gradually diagonally, (in several stages, until obtaining the required tightening torque) using a torque spanner. If a torque spanner is not available, one may use an ordinary spanner. The arm of the spanner (L) figure (5.4) should be selected according to the weight of the person (F) tightening the nut. Remember that this method of tightening is not as accurate as the use of a torque spanner.

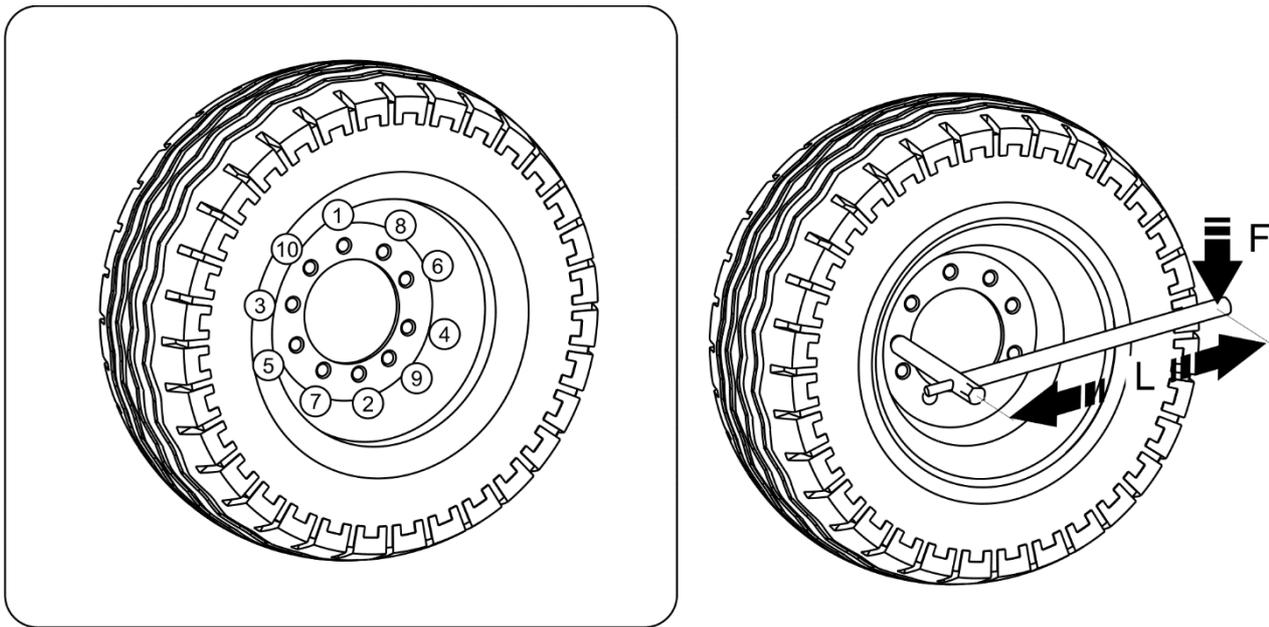

**FIG. 5.4** Sequence of tightening nuts, axles with 10 M22x1.5 pins

(1) - (10) sequence of nut tightening, (L) spanner length, (F) user weight

**IMPORTANT**



Axle nuts may not be tightened with impact wrench, because of danger of exceeding permissible tightening torque, the consequence of which may be breaking the thread connection or breaking off the hub pins.

The greatest precision is achieved using a torque spanner. Before commencing work, ensure that correct tightening torque value is set.

**TAB. 5.1** Spanner arm

WHEEL TIGHTENING TORQUE	BODY WEIGHT (F)	ARM LENGTH (L)
[NM]	[KG]	[M]
450	90	0.5
	80	0.55
	70	0.65
	60	0.75

**Checking wheel tightening:**

- after the first use of the manure spreader,
- after first travel with load,
- after travelling the first 1,000 km,
- every six months use or every 25,000 km.

In the event of intensive use of the manure spreader check the nut tightening at least every 10,000 km. The above actions should be repeated individually if a wheel has been removed from the wheel axle.

### 5.2.7 CHECK AIR PRESSURE, EVALUATE TECHNICAL CONDITION OF WHEELS AND TYRES

Tyre pressure should be checked each time after changing spare wheel and not less than every month. In the event of intensive use, air pressure in tyres should be checked more frequently. The manure spreader must be unloaded during checking. Checking should be done before travelling when tyres are not heated, or after an extended period of parking.

**TIP**

Tyre pressure values are specified in information decal, placed on wheel.

While checking pressure pay attention to technical condition of wheels and tyres. Look carefully at tyre sides and check the condition of tread.

In case of mechanical damage consult the nearest tyre service and check whether the tyre defect requires tyre replacement.

**DANGER**

Damaged tyres or wheels may be the cause of a serious accident.

Wheels should be inspected with regard to distortion, breaking of material, breaking of welds, corrosion, especially in the area of welds and contact with tyre.

Proper technical condition and appropriate maintenance of wheels significantly extends the life of these components and ensures appropriate level of safety to manure spreader users.



**Checking tyre pressure and steel rims:**

- every month of use,
- if needed.

### 5.2.8 MECHANICAL BRAKES ADJUSTMENT

During spreader operation drum brake linings are subjected to wear. Piston stroke extends, and exceeding braking force limiting value declines.

Adjustment must be made when:

- piston stroke amounts to 2/3 of maximum stroke,
- expansion levers are not set in parallel to each other during braking,
- repairs are made to braking system.

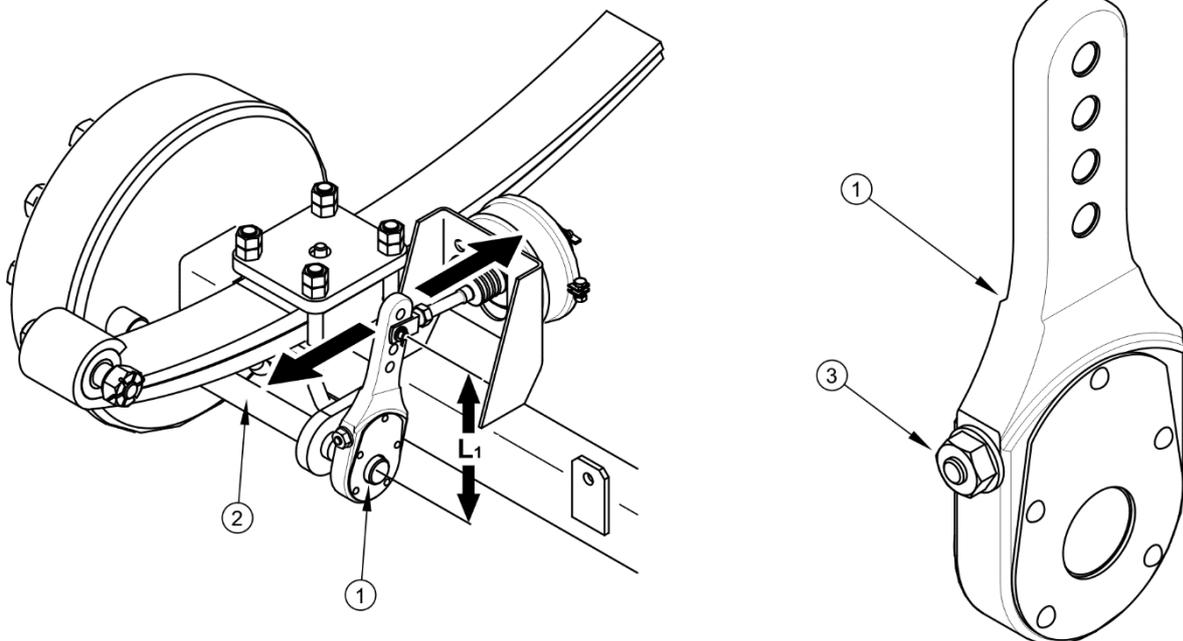

**FIG. 5.5 Adjustment of axle mechanical brakes**

(1) expander arm, (2) expander shaft, (3) adjustment bolt, ( $L_1$ ) – fork position

Brakes adjustment involves changing setting of axle shaft expander arm (1) in relation to expander shaft (2). To do this adjust the shaft position (1) with the aid of retaining bolt (3) in appropriate direction:

- ⇒ forward, if braking is too early,
- ⇒ backward, if breaking is too late.

Adjustment should be conducted separately for each wheel. After proper brake adjustment, at full braking, the expander arms should create the angle of 90° with the cylinder piston, and the stroke should amount to approximately half the length of the total stroke of the piston. After the brake is released, expander arms may not be supported on any structural elements, because insufficient withdrawal of a piston ram may cause abrasion of brake shoes in drum and result in overheating manure spreader brakes. Expander arms, placed on one axle, must be positioned in parallel with regard to each other at full braking. If this is not so, adjust the position of the expander, which has the longer stroke.



The main brake system should be inspected annually and in case of need should be adjusted.

During dismantling of cylinder fork remember or mark the original setting of the cylinder fork pin. The mounting position is selected by the Manufacturer and may not be changed.

**TAB. 5.2 Position of fork pin in expander arm**

TYPE OF BRAKE SYSTEM	PIN POSITION [mm]	
	FRONT AXLE (L <sub>1</sub> )	REAR AXLE (L <sub>1</sub> )
Double line pneumatic system	127	152
Double line pneumatic system with ALB.	127	152

### 5.2.9 CHANGE OF PARKING BRAKE CABLE AND ADJUSTMENT OF CABLE TENSION

Proper operation of the parking brake is dependent on the effectiveness of the front axle brake and the correct brake cable tension.

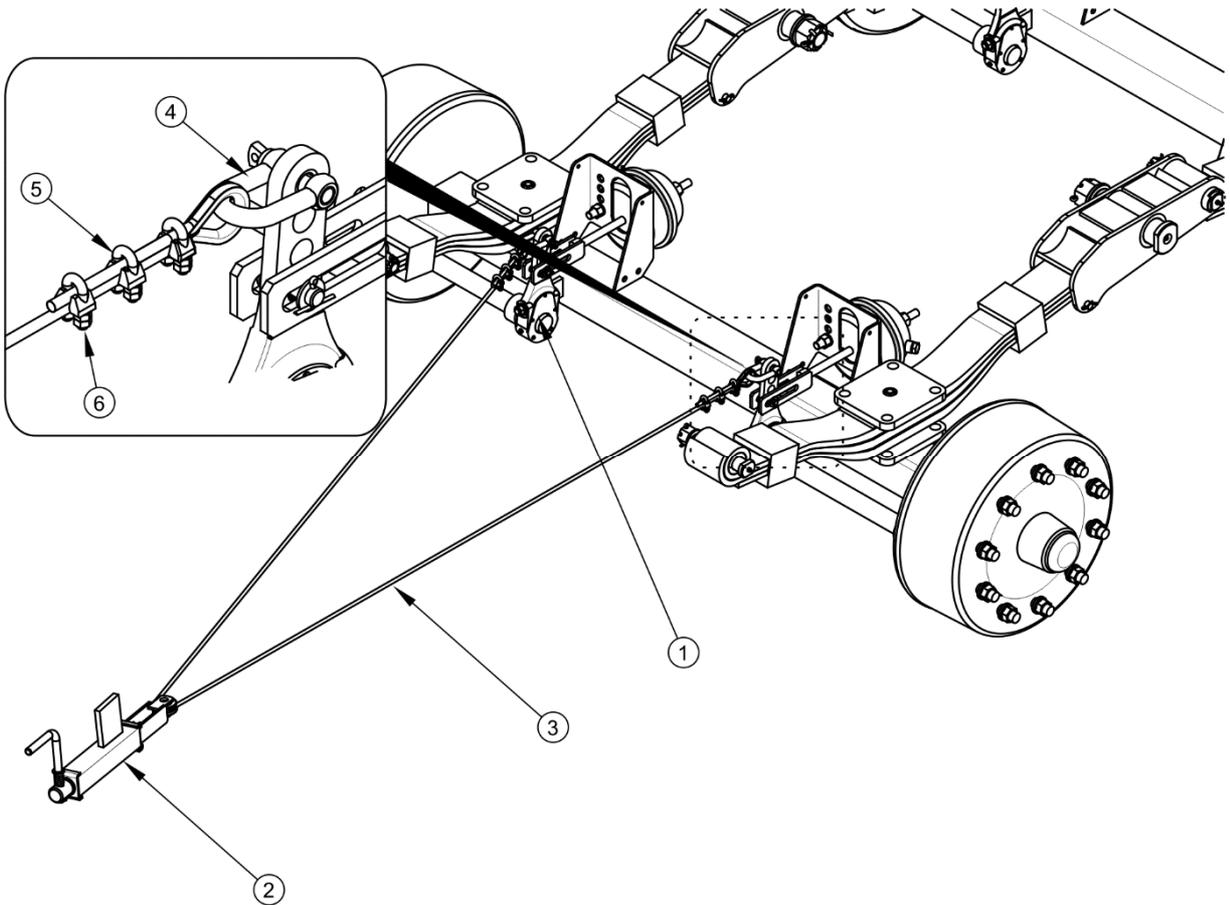

**FIG. 5.6 Adjustment of parking brake cable tension**

(1) expander arm, (2) brake crank mechanism, (3) brake cable, (4) shackle, (5) U-bolt clamp, (6) nuts of clamp

#### **Adjustment of parking brake cable tension**

- ➔ Connect the manure spreader to tractor. Park manure spreader and tractor on level surface.
- ➔ Place securing chocks under one manure spreader wheel.
- ➔ Fully unscrew the bolt of the brake crank mechanism (2) – figure (5.6), (anticlockwise).
- ➔ Loosen nuts (6) of clamps (5) of parking brake cable (3).
- ➔ Tighten cable and tighten clamps.

- ⇒ Length of parking brake cable (3) should be so selected that at total release of working and parking brake the cable would be loose and hanging by 1 - 2 cm compared to fully tensioned cable.

Adjustment of parking brake cable tension should be conducted in the event of:

- stretching of cable,
- loosening of parking brake cable clamps
- after adjustment of axle brakes,
- after repairs to axle brake system,
- after repairs in parking brake system.

Before commencing adjustment make certain that the main brake is correctly regulated and is functioning properly.



**Checking and parking brake adjustment:**

- every 12 months,
- if needed.

**Replacing the parking brake cable**

- ➔ Connect the manure spreader to tractor. Park manure spreader and tractor on level surface.
- ➔ Place securing chocks under one manure spreader wheel.
- ➔ Fully unscrew the bolt of the brake crank mechanism (2).
- ➔ Loosen nuts (6) of U-bolt clamps (5) located at the ends of cable.
- ➔ Dismantle shackle (4).
- ➔ Dismantle parking brake cable (3).
- ➔ Clean parking brake components, lubricate crank mechanism and pin of cable guide roller.
- ➔ Install new cable (3).

- ⇒ Parking brake cable must be fitted carefully.

- ⇒ Thimbles and three clamps must be fitted at the ends of the cable.
  - ⇒ Clamps must be tightened. The distances between the clamps may not be less than 30 mm.
  - ⇒ Clamp jaws must be placed at the load bearing cable side - see Figure (5.7).
  - ⇒ The first clamp should be placed directly on the thimble.
- ➔ After the first load of cable, re-check the condition of cable end, correct if necessary.

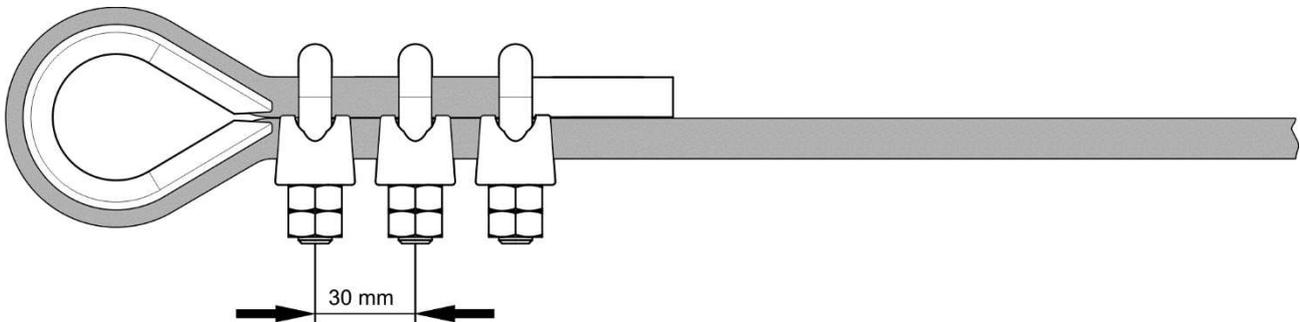

**FIG. 5.7** Installation of steel cable clamps

## 5.3 PNEUMATIC SYSTEM MAINTENANCE

### 5.3.1 PRELIMINARY INFORMATION

Work connected with the repair, change or regeneration of system components (brake cylinders, control valve, braking force regulator etc.) should be entrusted to specialist establishments, having the appropriate technology and qualifications for this type of work.

The duties of the operator connected with the pneumatic system include:

- inspecting and checking air tightness of system.
- cleaning the air filter (filters),
- draining water from air tank,
- clean drain valve,
- cleaning and maintaining pneumatic line connections,
- replacement of the pneumatic line.

**DANGER**

Do NOT use the manure spreader when brake system is unreliable.

**5.3.2 INSPECTING AND CHECKING AIR TIGHTNESS OF PNEUMATIC SYSTEM.****Checking hydraulic system tightness**

- ➔ Connect the manure spreader to tractor.
- ➔ Immobilise tractor and spreader with parking brake. Place chocks under spreader rear wheel.
- ➔ Start tractor in order to supplement air in manure spreader brake system tank.
  - ⇒ In single line systems air pressure should amount to approx. 5.8 bar.
  - ⇒ In double line systems air pressure should amount to approx. 8 bar.
- ➔ Turn off tractor engine.
- ➔ Check system components by releasing brake pedal in tractor.
  - ⇒ Give particular attention to conduit connections and brake cylinders.
- ➔ Repeat system check with depressed tractor brake pedal.
  - ⇒ The help of a second person is required.

In the event of the appearance of leaks, compressed air will escape at the places of damage, with a characteristic hiss. Lack of system tightness may be exposed by covering checked elements with washing fluid or other foaming preparations, which will not react aggressively with system components. Damaged components should be replaced or repaired. If leaks appear at connections then tighten the connections. If air continues to escape replace connection component or seal.

**Checking tightness of pneumatic system:**

- after travelling the first 1,000 km,
- each time after making repairs or changing system components,
- annually.

### Visual assessment of system

During tightness inspection attention should additionally be given to technical condition and degree of cleanness of the system components. Contact of pneumatic conduit seals etc. with oil, grease, petrol etc. may cause damage and accelerate the ageing process. Bent, permanently deformed, cut or worn conduits should be replaced.

	<b>Visual assessment of system</b>
<ul style="list-style-type: none"><li>• Conduct inspection of system at the same time as when checking tightness.</li></ul>	

	<b>IMPORTANT</b>
Repair, exchange or regeneration of pneumatic system components may only be performed in a specialised workshop.	

### 5.3.3 CLEANING THE AIR FILTERS

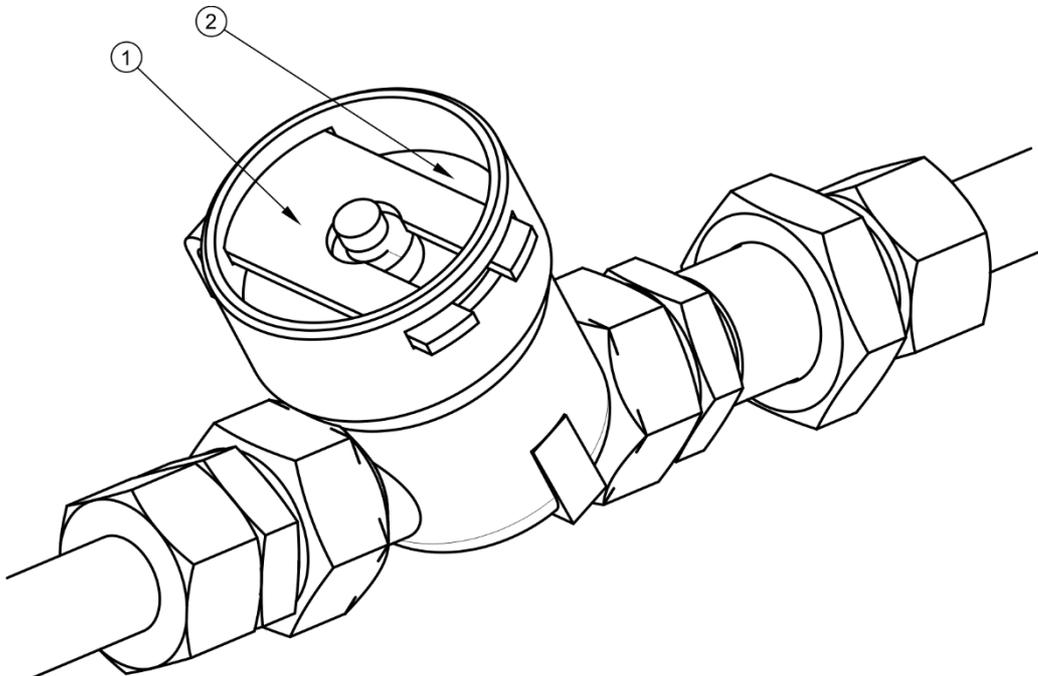

**FIG. 5.8**      **Air filter**

*(1) securing slide lock, (2) air filter cover*

**DANGER**

**Before proceeding to dismantle filter, reduce pressure in supply line. While disengaging filter slide gate, hold cover with other hand. Stand away from filter cover vertical direction.**

Depending on manure spreader working conditions, but not less than once in three months, take out and clean air filter inserts, which are located in pneumatic system connection lines. Inserts are used many times and are not subject to changing unless they are mechanically damaged.

**Required service actions**

- ➔ Reduce pressure in supply line.
  - ⇒ Reduction of pressuring line may be achieved by pressing the head of the pneumatic connection to resistance point.
- ➔ Remove securing slide (1) – figure (5.8).
  - ⇒ Hold the filter cover (2) with the other hand. After removing slide lock, the cover is pushed off by the spring, in the filter housing.
- ➔ The insert and the filter body should be carefully washed out and blown through with compressed air. Assembly should be done in reverse order.

**Cleaning the air filter (filters):**

- every 3 months of use,

### 5.3.4 DRAINING WATER FROM AIR TANK

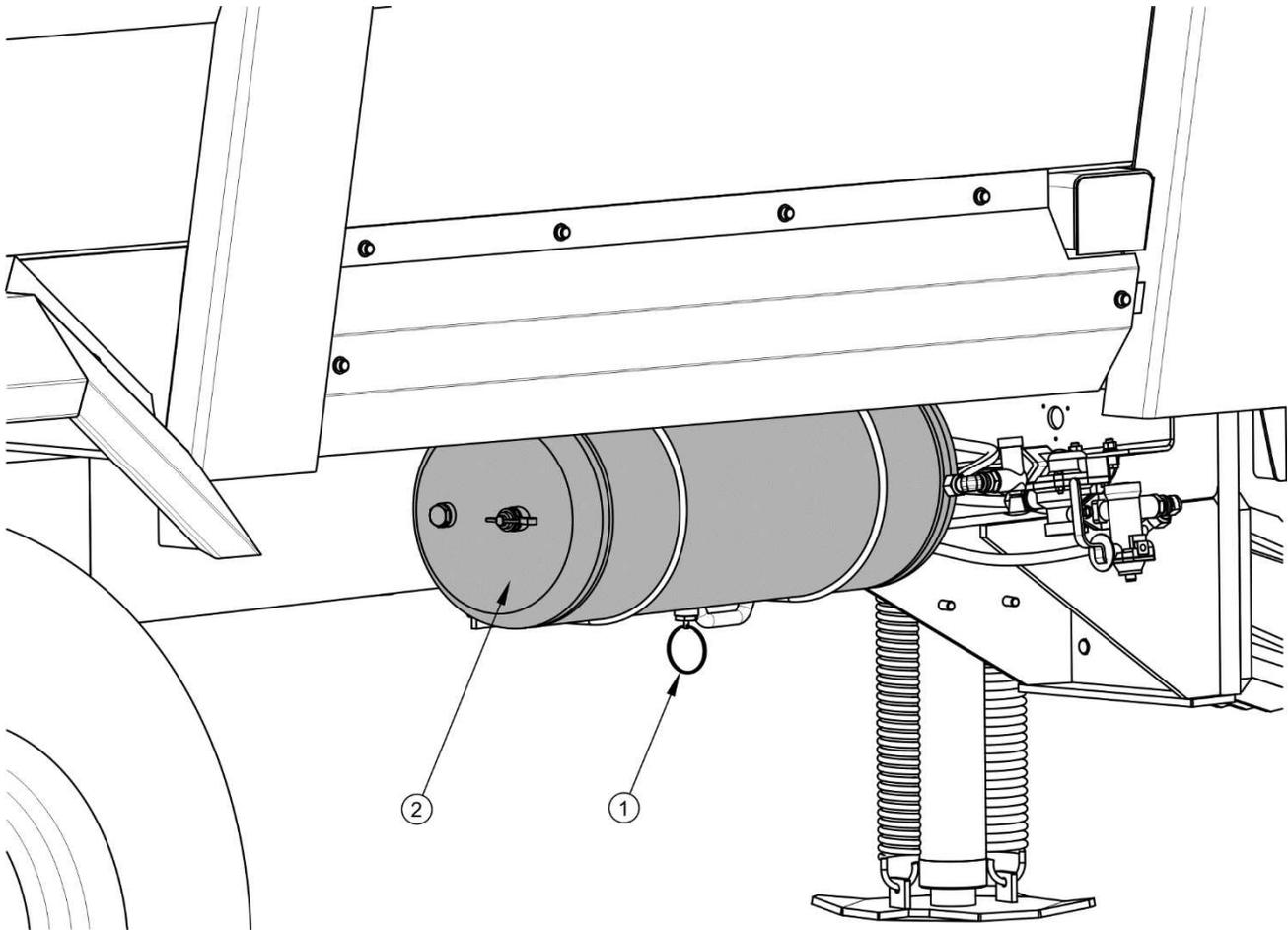
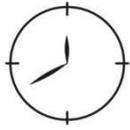

**FIG. 5.9**      **Draining water from air tank**

(1) *drain valve*, (2) *air tank*

#### **Required service actions**

- Open out drain valve (1) placed in lower part of tank (2).
  - ⇒ The compressed air in the tank causes the removal of water to the exterior.
- Released valve stem should automatically close and stop flow of air from the tank.
  - ⇒ In the event, that the valve stem resists returning to its setting, then the whole drain valve must be unscrewed and cleaned, or replaced (if it is damaged) - see section 5.3.5.

**Draining water from air tank:**

- after each week of use.

**5.3.5 CLEAN DRAIN VALVE****DANGER**

Before dismantling drain valve release air from tank.

**Required service actions**

- ➔ Reduce pressure in air tank.
  - ⇒ Reduction of pressure in tank is achieved by tilting the drain valve stem.
- ➔ Unscrew valve.
- ➔ Clean valve, purge with compressed air.
- ➔ Change copper seal.
- ➔ Screw in valve, fill air tank, and check tank tightness.

**Cleaning valve:**

- every 12 months (before winter period).

**5.3.6 CLEANING AND MAINTAINING PNEUMATIC LINE CONNECTIONS AND PNEUMATIC SOCKETS****DANGER**

Unreliable and dirty manure spreader connections may cause unreliability and faulty functioning of braking system.

In event of damage to cover or seal, change these elements for new reliable elements. Contact of pneumatic connector seals with oils, grease, petrol etc. may cause damage and accelerate ageing process.

If the manure spreader is unhitched from the tractor, contact should be protected by cover or placed in its designated socket. Before the winter period it is recommended to preserve the seal with special preparations (e.g. silicon grease for rubber elements).

Each time before connection of the machine inspect technical condition and cleanness of contacts and sockets in tractor. If necessary clean or repair tractor socket.



#### Checking the manure spreader connections:

- each time before hitching manure spreader to tractor.

### 5.3.7 REPLACEMENT OF THE PNEUMATIC LINE

Pneumatic lines should be replaced when permanently deformed, cut or frayed.

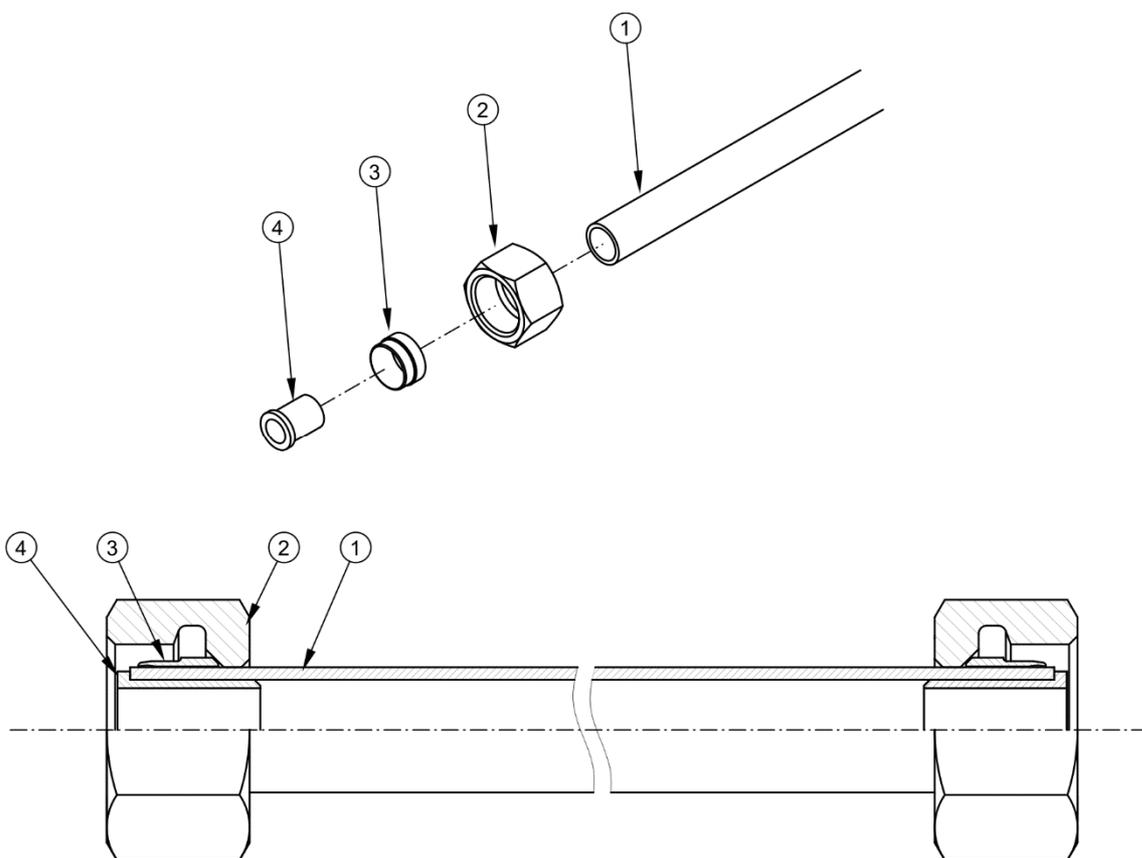

**FIG. 5.10** Installation of the pneumatic line

(1) pneumatic line, (2) connecting nut (3) clamping ring, (4) reinforcing sleeve

#### Required service actions

- ➔ Release all pressure from the system.

- ⇒ Reduction of pressure is achieved by tilting the drain valve mandrel.
- ➔ Remove the pneumatic line by loosening the nut (2).
- ➔ Fit the new line.
  - ⇒ The interior of the line should be clean.
  - ⇒ The ends of the pneumatic line (1) must be cut exactly at right angles.
  - ⇒ Clamping ring (3) should be fitted according to figure (5.10).
  - ⇒ Reinforcing sleeve (4) of the line must be thoroughly depressed.
- ➔ Check tightness of connections in accordance with Chapter (5.3.2).

## 5.4 HYDRAULIC SYSTEM OPERATION

Always adhere to the principle that the oil in the manure spreader hydraulic system and in the tractor hydraulic system are of the same type. Application of different types of oil is not permitted. In a new manure spreader, the hydraulic system is filled with L HL32 Lotos hydraulic oil.

The manure spreader's hydraulic system should be completely tight sealed. Checking tightness of the hydraulic system involves connecting the machine with the tractor and activating hydraulic brakes several times by pressing the brake pedal in the tractor operator cab and actuating the hydraulic cylinders of the spreader unit's slide gate and tailgate. Hold the hydraulic cylinders in position of maximum extension for 30 seconds. In the event of confirmation of an oil leak on hydraulic line connections, tighten connections, and if this does not remedy faults then change line or connection elements. If oil leak occurs beyond connection, the leaking line system should be changed. Change of sub-assemblies is equally required in each instance of mechanical damage. In the event of confirmation of oil on hydraulic ram cylinder bodies ascertain origin of leak. Inspect hydraulic seals when ram cylinders are completely extended. Minimum leaks are permissible with symptoms of "sweating", however in the event of noticing leaks in the form of "droplets" stop using the spreader until faults are remedied.

**TAB. 5.3 L-HL32 Lotos hydraulic oil characteristics**

ITEM	NAME	VALUE
1	ISO 3448VG viscosity classification	32
2	Kinematic viscosity at 40°C	28.8 – 35.2 mm <sup>2</sup> /s
3	ISO 6743/99 quality classification	HL
4	DIN 51502 quality classification	HL

In the event of necessity of changing hydraulic oil for another oil, check the recommendations of the oil Manufacturer very carefully. If it is recommended to flush the system with the appropriate preparation, then comply with these recommendations. Attention should be given, so that chemical substances used for this purpose do not damage the materials of the hydraulic system.



**Hydraulic lines should be replaced after 4 years of manure spreader use.**  
**Detailed tightness and technical condition inspection of hydraulic system should be made at least annually.**

The oil used in the hydraulic system is not classified as a dangerous substance, however long-term action on the skin or eyes may cause irritation. In the event of contact of oil with skin wash the place of contact with water and soap. Do NOT apply organic solvents (petrol, kerosene). Contaminated clothing should be changed to prevent access of oil to skin. In the event of contact of oil with eye, rinse with large quantity of water and in the event of the occurrence of irritation consult a doctor. Hydraulic oil in normal conditions is not harmful to the respiratory tract. A hazard only occurs when oil is strongly atomised (oil vapour), or in the case of fire during which toxic compounds may be released. Oil fires should be quenched with the use of carbon dioxide, foam or extinguisher steam.

**ATTENTION**



**Manure spreader with a leaking hydraulic system must NOT be used.**  
**The condition of hydraulic systems should be inspected regularly while using the manure spreader.**  
**The hydraulic system is under high pressure when operating.**  
**Regularly check the technical condition of the connections and the hydraulic conduits.**  
**Use the hydraulic oil recommended by the Manufacturer. Never mix two types of oil.**

## 5.5 REDUCTION GEAR MAINTENANCE

All reduction gears in Pronar manure spreader are pre-filled with SAE 90 EP (API GL-5 SAE 80W/90) gear oil.

**TAB. 5.4** Quantity of oil in the manure spreader's reduction gears

POSITION OF REDUCTION GEAR		TYPE OF GREASE	NUMBER OF ITEMS
Feeding mechanism		SAE 90 EP (API GL-5 SAE 80W/90)	6.6l
Wide spread mechanism	central		1.7l
	right		1.2l
	left		1.2l
Power transmission mechanism			2.8l

Such symptoms as fresh stains of oil and increased noise level of the gear may indicate that oil level is too low.



**Oil level in the feeding mechanism gear should be checked through the transparent sight-glass before each start of the machine.**

Oil change should be conducted at working temperature, if the machine has worked for several minutes, then possible contamination, in the transmission is mixed with the oil and then is drained out with it.



**Change oil after the first 50 hours of work and then every 500 hours**



### **DANGER**

**When checking oil level and changing oil, use appropriate personal protection equipment i.e. protective clothing, safety shoes, gloves, safety goggles. Avoid contact of skin with oil.**

## 5.6 MANURE SPREADER LUBRICATION

Manure spreader lubrication must be carried out in places indicated in figures (5.11) & (5.12), and also detailed in table (5.6). The manure spreader is equipped with grease nipples facilitating maintenance and marked with yellow labels (item 14 – table (2.1)).

**TAB. 5.5 Recommended lubricants**

LISTED ON TAB. (5.6)	DESCRIPTION
A	machine general-purpose grease (lithium, alkaline),
B	permanent grease for heavily loaded elements with addition of MOS <sub>2</sub> or graphite
C	anticorrosion preparation in aerosol
D	ordinary machine oil, silicon grease in aerosol

Manure spreader lubrication should be performed with the aid of a manually or foot operated grease gun, filled recommended grease. Before commencing work insofar as is possible remove old grease and other contamination. Remove and wipe off excess oil or grease.

**TAB. 5.6 Lubrication schedule**

ITEM	LUBRICATION POINT	NUMBER OF LUBRICATION POINTS	TYPE OF GREASE	FREQUENCY
1	Hub bearings	4	A	24M
2	Drawbar eye	1	B	14D
3	Leaf spring absorber pin	4	A	3M
4	Rocker arm pin	2	B	3M
5	Leaf spring absorber sliding surface	4	B	1M

ITEM	LUBRICATION POINT	NUMBER OF LUBRICATION POINTS	TYPE OF GREASE	FREQUENCY
6	Parabolic leaf springs	4	C	6M
7	Parking brake mechanism	1	A	6M
8	Ladder pin	1	D	3M
9	Tensioning bolt	4	A	6M
10	expander shaft lever	4	A	6M
11	Surface of multi-splined drive shaft	1	A	6M
12	Hydraulic cylinder ram eye	8	A	3M
13	Tailgate securing pin	2	A	3M
14	Front axle sprocket bearings	4	A	8H
15	Bearings of spreader unit wormshafts and bearings of chain conveyor mechanism shaft	7	A	8H
16	Articulated joints of shafts	8	A	50H
17	Chain tensioner sleeve	2	A	3M
18	Drive chain of spreader unit wormshafts	2	B	30H

*lubrication periods – M month, D – days, H – working hour*

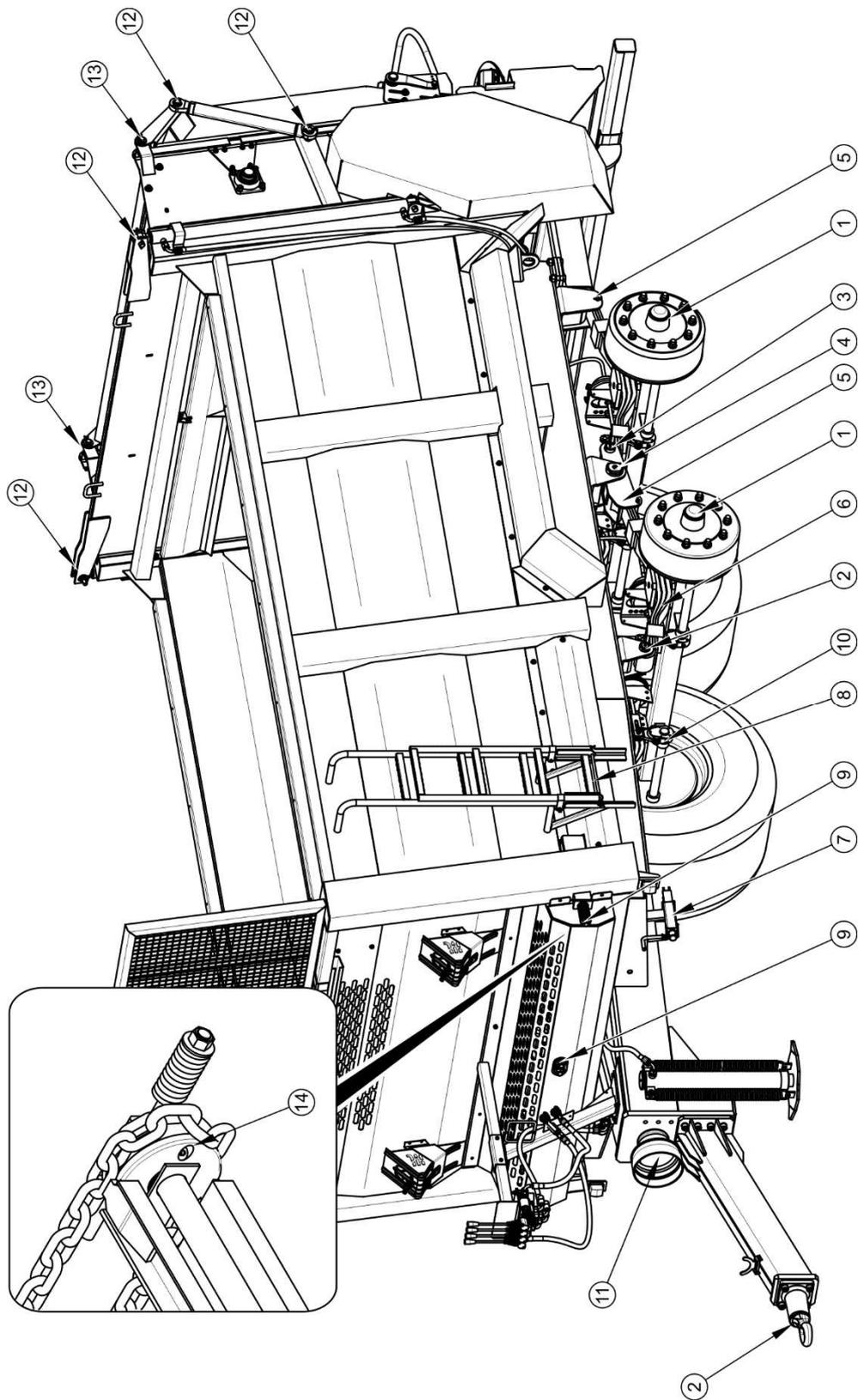

FIG. 5.11 Spreader's lubrication points N262

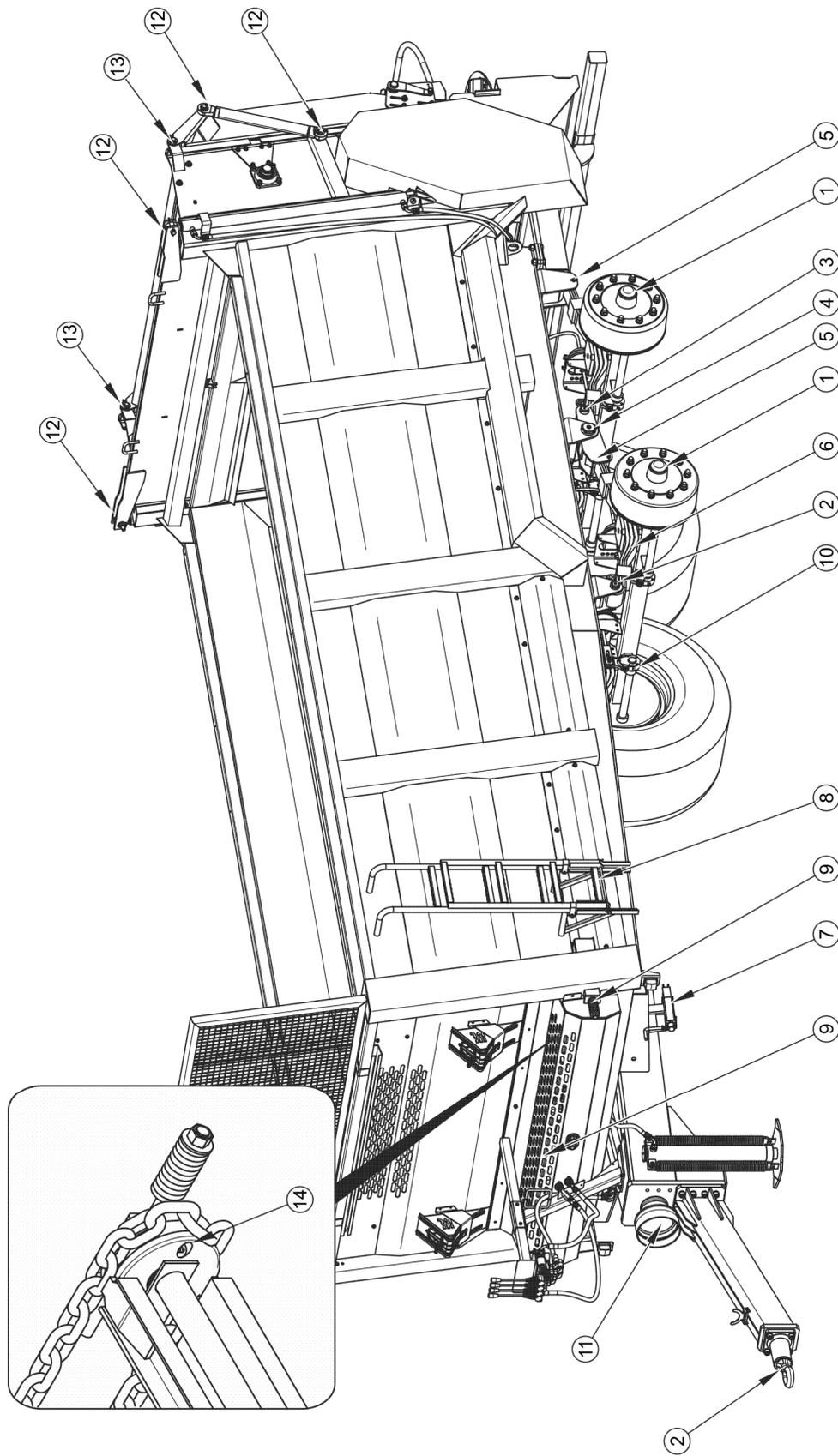
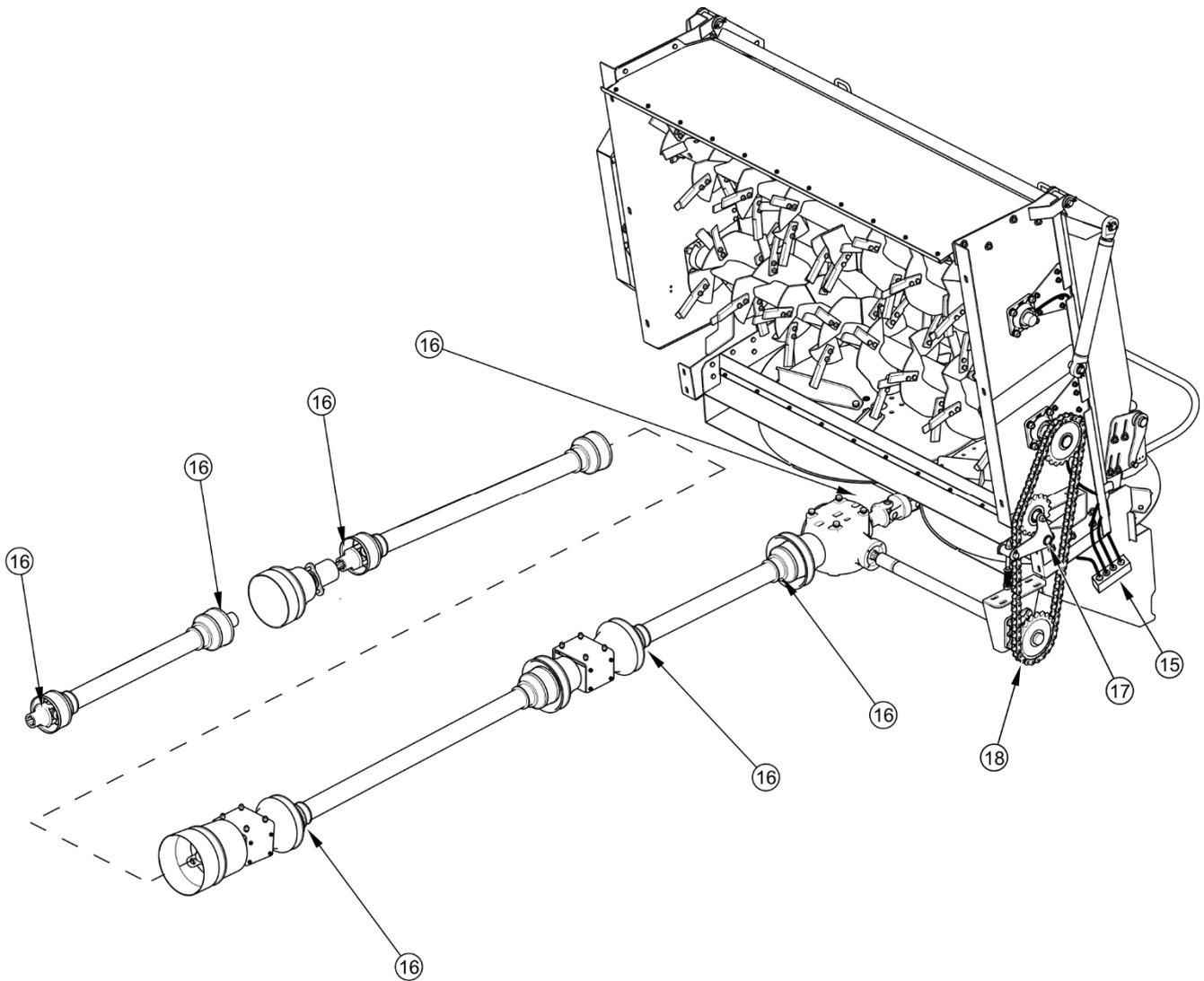

FIG. 5.12 Spreader's lubrication points N262/1



**FIG. 5.13 Spreader's lubrication points N262, N262/1**

Before beginning to grease leaf springs remove contamination, wash with water and leave to dry. Do not use pressure washers, which may cause moisture penetration between individual leaf springs. Absorber plates should be lubricated using an agent having both anticorrosion and lubricating properties, it is recommended to apply on outer leaf spring surfaces very thin layer of lithium or lime alkali grease. For this purpose, silicone spray (for lubricating of guides, lock etc. see table) can be used. Sliding surface of leaf spring and leaf spring pin should be lubricated according to recommendations contained in table (5.6).

Parts, which should be lubricated with machine oil, should be wiped with dry cleaning cloth and then a small quantity of oil should be applied do surfaces (with oil can or brush). Wipe off excess oil.



### **ATTENTION!**

Lubricate all lubrication points after the first month of use.

After finishing washing wait until trailer is dry and then grease all inspection points according to recommendations. Remove excess oil or grease with a dry cloth.



When using the D – days the user is obliged to observe lubrication instructions according to attached schedule. Excess oil or grease causes depositing additional contaminants in places requiring lubrication, therefore it is essential to keep individual machine elements clean.

Change of grease in hub bearings should be entrusted to specialised service points, equipped with the appropriate tools. According to the recommendations of the axle Manufacturer, dismantle the entire hub, remove the bearing and individual sealing rings. After careful washing and inspection, mount lubricated elements. If necessary, bearing and seals should be replaced with new parts. Lubrication of axle bearings shall be performed at least once in 2 years or every 50,000 km. In the event of intensive use, lubrication should be performed more frequently.

Empty grease or oil containers should be disposed of according to the recommendations of the lubricant Manufacturer.

## **5.7 CLIMBING INTO THE LOAD BOX**



### **DANGER**

Before climbing on to the load box, make sure unauthorised persons do not have access to the tractor, disconnect PTO shaft and disconnect hydraulic system lines from the tractor.

Exercise caution when climbing on top of the load box.

While climbing on to the manure spreader's load box, the manure spreader must be absolutely motionless.

During manure spreader operation there is often a need to climb into the load box to carry out an inspection, adjustment or cleaning. This must be done with extreme caution because of the high risk of accident. In order to do this:

- ➔ immobilise tractor and manure spreader with parking brake,
- ➔ turn off tractor engine and remove key from ignition,
- ➔ secure tractor against unauthorised access,
- ➔ disconnect hydraulic system lines,
- ➔ disconnect PTO shaft connecting tractor and spreader
- ➔ climb into the load box with due caution.

## 5.8 CLEANING

Carefully remove the remains of manure from the manure spreader daily after finished work. It is recommended to do this using a pressure washer. In order to do this:

- ➔ Open slide gate and tailgate.
  - ⇒ Protect tailgate from falling down by closing the cut-off valve and with a suitable mechanical support which is durable and stably mounted. Mechanical support should be placed between tailgate and floor conveyor strip.
- ➔ Immobilise tractor and spreader with parking brake.
- ➔ Place chocks under manure spreader wheel.
- ➔ Turn off tractor engine and remove key from ignition.
- ➔ Secure tractor against access of unauthorised persons.
- ➔ Clean the manure spreader with strong water jet and leave to dry.
  - ⇒ Using pressure washer increases washing effectiveness, but particular care must be taken during work. During washing, washer nozzle may not be closer than 50 cm from the surface being cleaned.
  - ⇒ Using excessive pressure for cleaning may damage lacquer coating.

- ⇒ Do not direct water stream directly at system and equipment elements of manure spreader i.e. control valve, braking force regulator, brake cylinders, pneumatic, electric and hydraulic plugs, lights, electrical connections, information and warning decals, identification plates, line connections and lubrication points etc. High water jet pressure may damage these elements.
- ➔ For cleaning and maintenance of plastic coated surfaces it is recommended to use clean water or special preparations designed for this purpose.
- ➔ Do not apply organic solvents, preparations of unknown origin or other substances, which may cause damage to lacquered, rubber or plastic surfaces. In the event of doubt it is recommended to make a test on an unseen surface area.
- ➔ Surfaces smeared with oil or grease should be cleaned by application of benzene or other degreasing agents and then washed with clean water with added detergent. Comply with recommendations of the Manufacturer.

## **DANGER**



**Carefully read the instructions for application of washing detergents and maintenance preparations.**

**While washing with detergents wear appropriate protective clothing and goggles protecting against splashing.**

**During service with the tailgate raised, protect it from falling down by closing the cut-off valve and with a suitable mechanical support which is durable and stably mounted.**

**Switch tractor engine off and disengage PTO shaft before cleaning the machine and standing on the chain conveyor strips.**

- ➔ Washing detergent should be kept in original containers, optionally in replacement containers, but very clearly marked. Preparations may not be stored in food and drink containers.
- ➔ Unsure cleanliness of elastic conduits and seals. The plastic from which these elements are made may be susceptible to organic substances and some detergents. As a result of long-term reaction of some substances, the ageing process may be accelerated and risk of damage increased. Rubber elements

should be maintained with the aid of special preparations after previous thorough washing.

- ➔ Observe environmental protection principles and wash manure spreader in a place designed for this purpose.
- ➔ Washing and drying manure spreader must take place at temperatures above 0°C.
  - ⇒ In winter, freezing water may cause damage to paint coating or machine elements.

### ATTENTION



Remove the remains of manure from the manure spreader each time after finished work. During work use the proper, close-fitting protective clothing, gloves and appropriate tools.

Take care not to lower or rise the tailgate when it is locked using a cut-off valve. Otherwise, hydraulic cylinders and/or tailgate may be damaged.

## 5.9 PREPARATION FOR END OF SEASON

After finishing fieldwork the manure spreader must be properly prepared for winter storage.

In order to do this:

- thoroughly remove the remaining manure and wash off in accordance with Chapter 5.8,
- check technical condition of: bearings, shields, chains, electrical system, pneumatic system and indicators,
- grease all inspection points of the manure spreader,
- check air pressure in tyres,
- corroded or damaged surface should be cleaned and properly protected with a thin layer of grease, anticorrosion preparation or priming paint,
- secure PTO shaft, check condition of its shields, grease moving elements of PTO shaft,

- check visually the components which wear most frequently and replace them if necessary,
- tyres should be preserved at least once a year using generally available substances for this purpose.

## **5.10 PREPARATION FOR THE BEGINNING OF A NEW FIELDWORK SEASON**

- Check technical condition of bearings, shields, chains.
- Check spreader unit knives and replace them if necessary.
- Check technical condition of the electrical system; Check whether lights work correctly.
- Check leaktightness of pneumatic system and hydraulic system.
- Check state of wear of hydraulic hoses. Immediately replace worn or damaged hydraulic hoses.
- Check technical condition of PTO shaft, its shields and securing chains.
- Check oil level in the spreader unit transmission.
- Check oil level in the transfer mechanism transmission.
- Grease all inspection points of the manure spreader,
- Check air pressure in tyres,
- Check tension of the floor conveyor chain, adjust if necessary.
- Check setting of brake lever, adjust if necessary.
- Check condition of bolt connections, tighten if necessary.
- Check degree of drawbar wear.
- Check drawbar and frame for scratches and fractures.
- Check state of wear of the floor conveyor mechanism's strips, if necessary replace them with new ones.

## 5.11 STORAGE

- After finishing work, the manure spreader should be thoroughly cleaned and washed in accordance with Chapter 5.8.
- In the event of damage to the lacquer coating clean those places from rust and dirt, degrease and then paint with paint maintaining uniform colour and even thickness of protective coating. Until the time of touch-up painting, the damaged place should be covered with a thin layer of grease, anticorrosion preparation or priming paint.
- It is recommended to keep the manure spreader in a closed or roofed building.
- Before longer outdoor storage, it is essential to protect the machine against adverse weather conditions, especially those causing corrosion and accelerated ageing of tyres.
- In the event of prolonged work stoppage, it is essential to lubricate all elements regardless of the period of the last lubrication process.
- Wheel rims and tyres should be carefully washed and dried. During longer storage it is recommended that every 2 to 3 weeks the machine may be moved a bit so that the place of contact of tyres with ground is changed. The tyres will not be deformed and maintain proper geometry. Also tyre pressure should be inspected from time to time, and if necessary pressure should be increased to appropriate value.
- PTO shaft for connection with tractor should be stored in the horizontal position.

## 5.12 REPLACEMENT OF THE SPREADING MECHANISM BLADES



### **DANGER**

Spreading disc blades may be checked and replaced only if the machine is disconnected from the tractor.

Technical condition of spreading disc blades should be checked periodically paying attention to mechanical damage, excessive wear and completeness of securing elements.

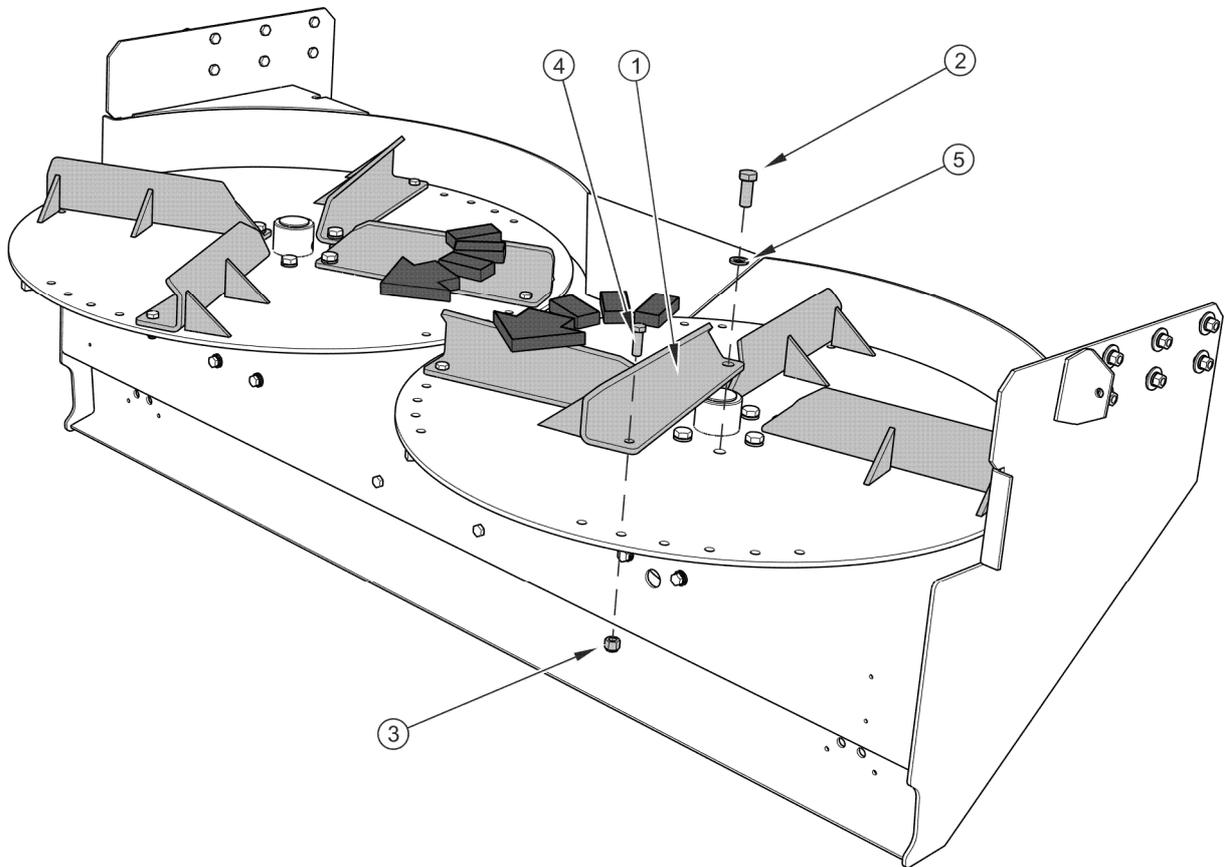

**FIG. 5.14 Replacing spreading disc blades**

(1) blade, (2) M16x40 bolt, (3) M12 self locking nut, (4) M12x30 bolt, (5) Z16,3 spring washer

In order to replace a spreading disc blade (1):

- ➔ unscrew nut (3),
- ➔ take out bolt (4) ,
- ➔ unscrew bolt (2) and remove washer (5),
- ➔ replace blades (1) with new ones, check condition of bolts and nuts, if necessary replace,
- ➔ install in reverse order.

All blades are replaced in the same way. When installing a blade, pay attention to rotation direction of spreading disc and mounting in proper holes.

## 5.13 CHECKING AND REPLACEMENT OF SPREADER UNIT KNIVES

Spreader unit knives must be regularly checked. Visually inspect the knives and fixing bolts and check tightening torque of nuts. This inspection is particularly important when spreading manure which may contain stones or other foreign bodies and after installation of new cutting knives and after the first start-up of the machine.

Excessively worn or damaged knives and fixing bolts must be replaced with new ones. The bolts should be mounted with their heads on the outside, when seen from the centre of the wormshaft. Tighten the nuts of fixing bolts with torque of 90 Nm.

### DANGER



During work check source of unnatural vibrations and noises, which may come from the machine.

Before replacement turn off tractor engine and remove the key from the ignition and engage tractor parking brake. Ensure that unauthorised persons do not have access to the tractor.

Protect tailgate from falling down by closing the cut-off valve and with a suitable mechanical support which is durable and stably mounted. Mechanical support should be placed between tailgate and floor conveyor strip.

### ATTENTION



If a knife is lost, vibration may occur, which may cause damage to the wormshaft bearings.

Before securing knives, it is necessary to check the direction of wormshaft rotation. Reverse setting of knives will cause poor disintegration of material spread.

Parts should always be replaced with original parts.

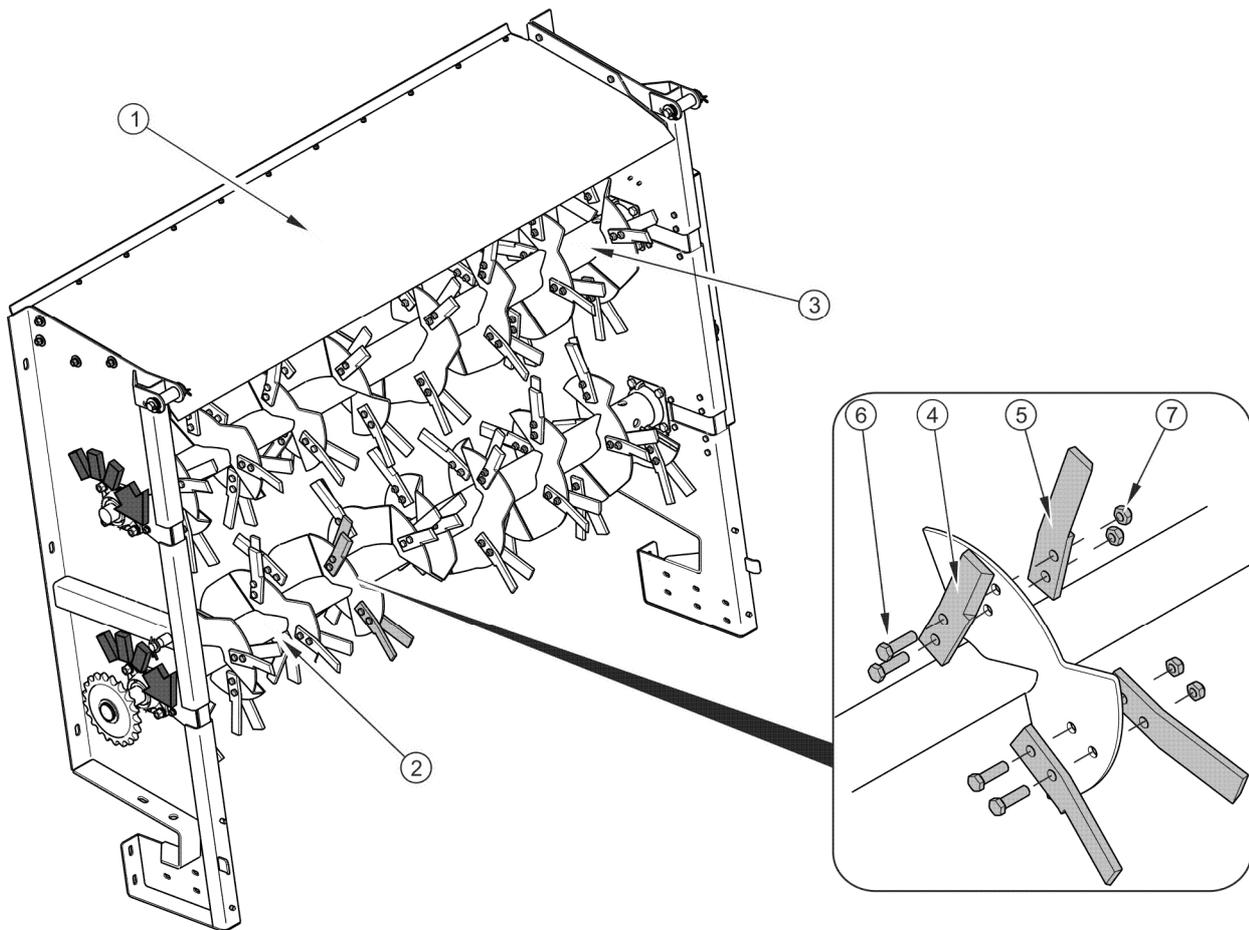
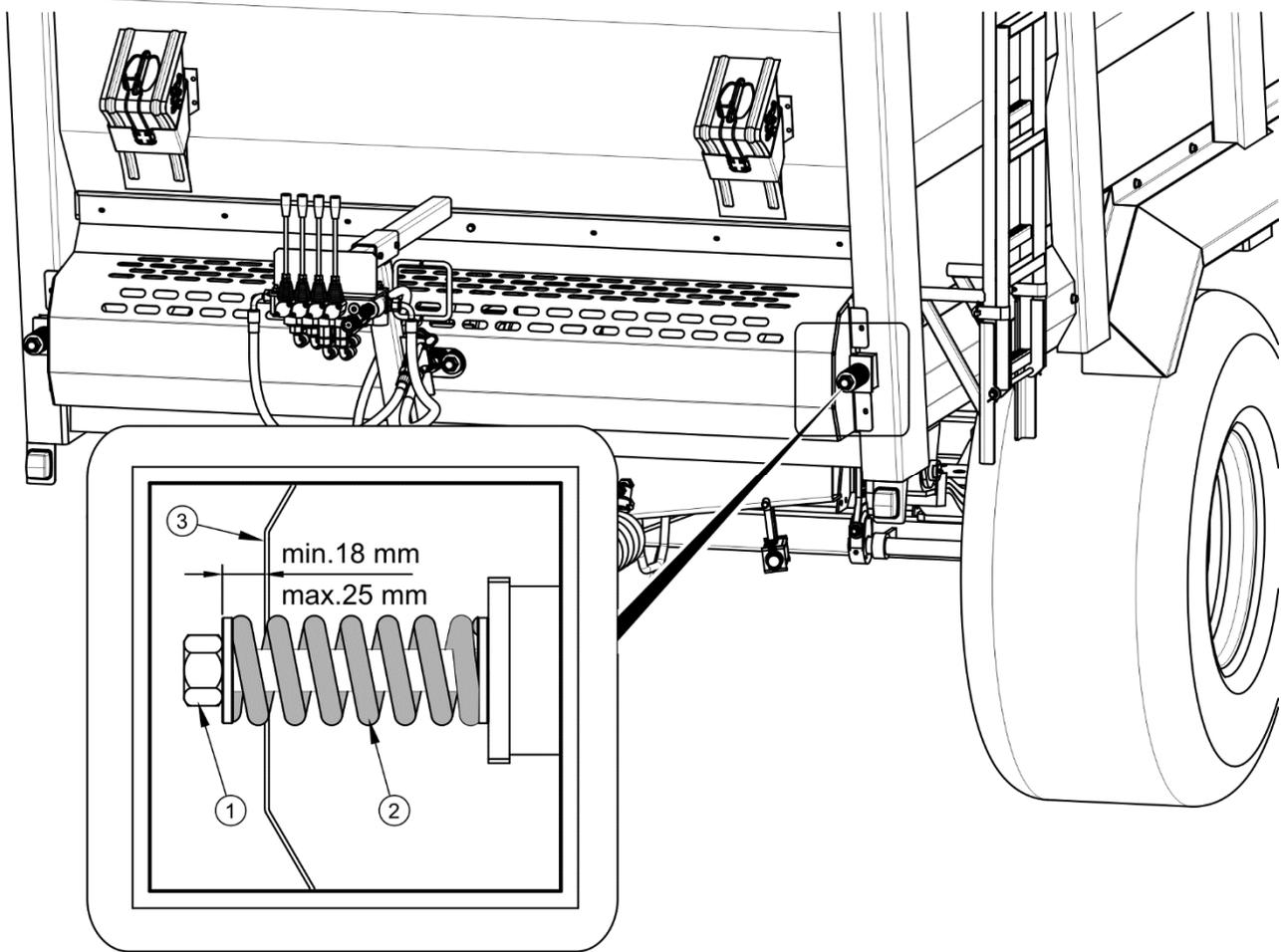

**FIG. 5.15 Replacement of the disintegrating knives of the spreader unit mechanism**

(1) spreader unit, (2) lower wormshaft, (3) upper wormshaft, (4) left knife, (5) right knife, (6) M12x45 bolt, (7) M12 nut

## 5.14 CHECKING AND ADJUSTMENT OF TENSION OF FLOOR CONVEYOR CHAIN

Tension of floor conveyor chain must be checked daily, in particular, at the beginning of the conveyor's working period. Tension is measured at the front tension mechanism springs, at the front of the load box - Figure (5.15).



**FIG. 5.16**      **Adjusting the floor chain tension**

*(1) adjustment bolt, (2) tension spring, (3) front spring of conveyor*

Tension of chains is adjusted by the tension spring (2) using the adjusting screw (1). The tension is correct when the distance between the bolt washer (1) and front shield (3) of conveyor is 18 - 25 mm - Figure (5.16).

	<b>ATTENTION</b>
<b>All conveyor chains must be equally tensioned.</b>	

## 5.15 OPERATION OF ELECTRICAL SYSTEM AND WARNING ELEMENTS

### 5.15.1 PRELIMINARY INFORMATION

Work connected with the repair, change or regeneration of electrical system components should be entrusted to specialist establishments, having the appropriate technology and qualifications for this type of work.

The responsibilities of the user are limited to:

- technical inspection of electrical system and reflectors,
- Changing bulbs



#### IMPORTANT

Do NOT travel with unreliable lighting system. Damaged lamp lenses, and burned-out bulbs must be replaced immediately before travelling. Lost or damaged reflective lights must be replaced.

#### Required service actions

- ➔ Hitch manure spreader to tractor with appropriate connection lead.
  - ⇒ Check if the connection lead is reliable. Check connection sockets in tractor and manure spreader.
- ➔ Check completeness and technical condition of manure spreader lights.
- ➔ Check completeness of all reflectors.
- ➔ Check correct mounting of triangular slow-moving vehicle sign.
- ➔ Before driving on to public road check that the tractor is equipped with warning reflective triangle.



#### Checking technical condition of electrical system:

- each time while connecting the manure spreader.



**TIP**

Before driving away make certain that all lamps and reflective lights are clean.

**5.15.2 CHANGING BULBS**

Bulb set is presented in table (5.7). All light lenses are secured by screws and it is not necessary to dismantle whole lamp or trailer subassemblies.

**TAB. 5.7 List of bulbs**

LAMP	LAMP TYPE	BULB / QUANTITY IN 1 LAMP	NUMBER OF LAMPS
Rear left lamp assembly	WE 549L	R10W / 1 unit P21W / 2 units	1
Rear right lamp assembly	WE 549P	R10W / 1 unit P21W / 2 units	1
Front parking light	LO-110PP	C5W / 1 unit	2



**ATTENTION**

The manure spreader's electrical system is supplied with 12V.

**5.16 ADJUSTMENT OF THE UPPER DRAWBAR EYE POSITION**

Position of the manure spreader drawbar is selected depending on the type of agricultural tractor hitch to be used to hitch the manure spreader. If possible, we recommend adjusting the tractor hitch so that the spreader drawbar (3) is positioned horizontally while driving on a flat terrain.

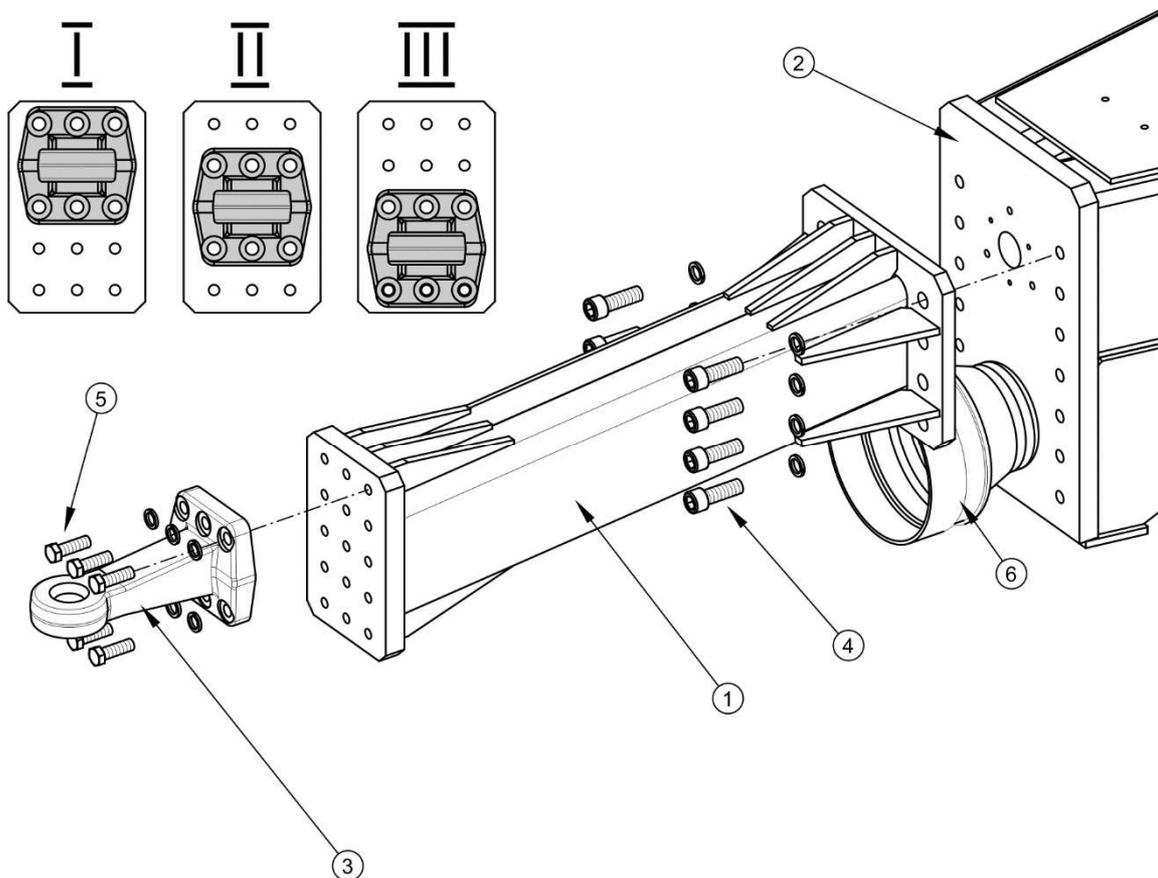

**FIG. 5.17 Mounting the upper drawbar**

(1) upper drawbar, (2) faceplate, (3) fixed drawbar eye, (4) drawbar retaining bolt, (5) drawbar eye retaining bolt, (6) shaft terminal cover with PTO connector

### Changing the upper drawbar eye position

- ➔ Immobilise the manure spreader with parking brake.
- ➔ Place securing chocks under wheels.
- ➔ Dismantle drawbar eye (3) from the faceplate by unscrewing bolts (5).
  - ⇒ The design of the upper drawbar (1) makes it possible to set the drawbar eye in three positions (I), (II), (III) - Figure (5.17),
- ➔ Set and attach the drawbar eye (3) with bolts (5) using tightening torque according to table (5.8).
  - ⇒ To prevent premature wear of the drawbar make sure it is positioned horizontally at the tractor hitch point.

## 5.17 MAINTENANCE OF CHAIN TRANSMISSIONS



### **DANGER**

**Before you begin the adjustment, turn off the machine drive and ensure that unauthorised persons have no access to the tractor cab.**

If chain transmissions work too noisily, adjust tension of chains that are located on both sides of the spreader unit, under the side covers. Noisy operation is a symptom of excessive looseness of chains, which increases during machine operation. Lengthening of chain, which causes noisy operation, is a normal symptom.

In order to adjust drive chain tension:

- ➔ disconnect PTO shaft from tractor,
- ➔ open side cover (1) and secure it against accidental closing,
- ➔ check play of chain,
  - ⇒ correct chain play, measured halfway along the length of its working section, should be from 5 to 15 mm
- ➔ using bolt (4) and nut (5), set the tensioner in such a position as to ensure that the chain is correctly tensioned,
  - ⇒ If it is impossible to adjust the chain tension (the chain is excessively stretched), replace the chain with a new one.
- ➔ lubricate the chain after checking and adjusting and reinstall the side cover.

Checking and adjustment of the chain tension on the right side of the spreader unit should be carried out in the same way.

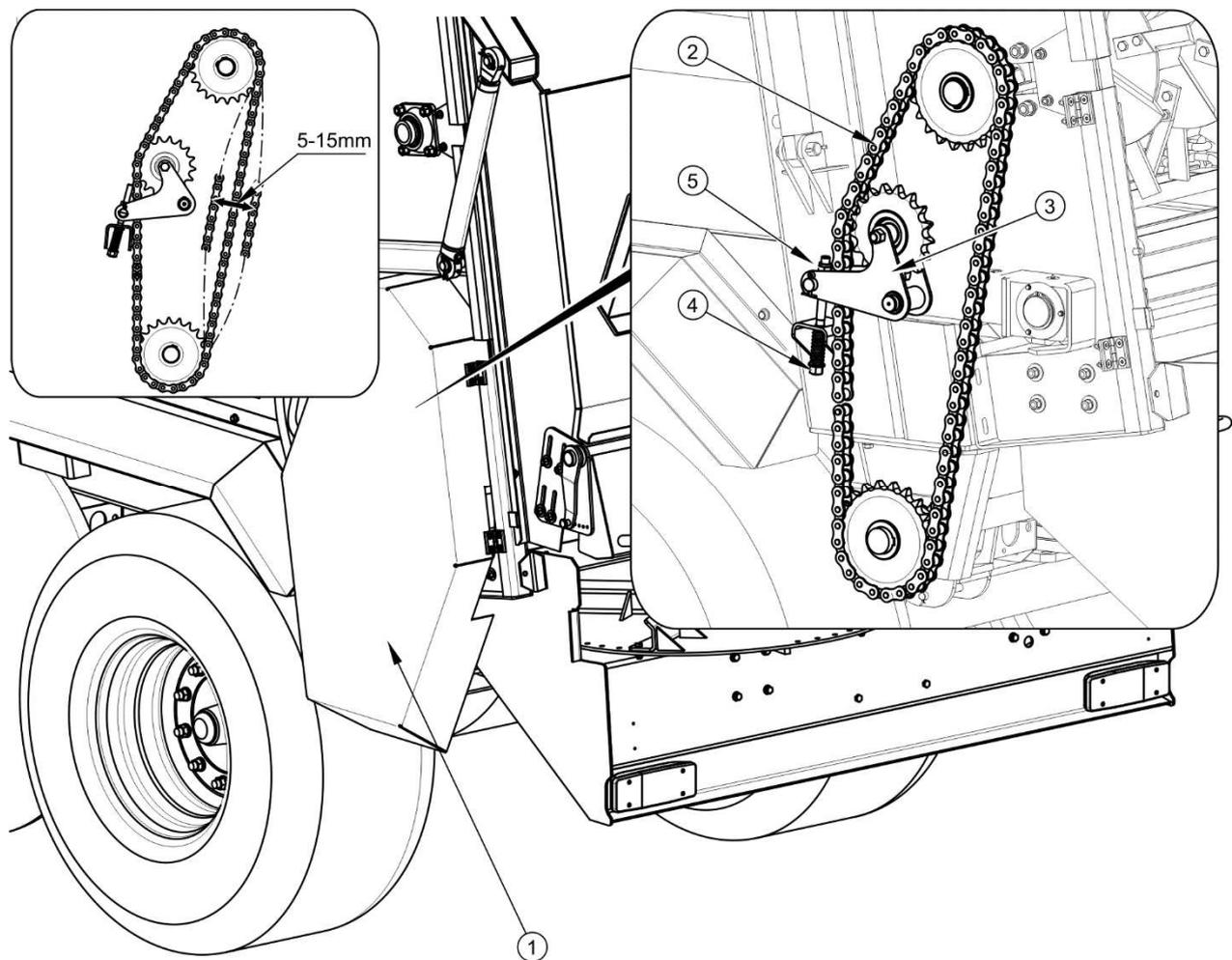

**FIG. 5.18** Adjusting the chain transmission

(1) side cover, (2) drive chain, (3) tensioner, (4) tensioner bolt, (5) nut

## 5.18 TIGHTENING TORQUE FOR NUT AND BOLT CONNECTIONS

Unless other tightening parameters are given, during maintenance repair work apply appropriate torque to tightening nut and bolt connections. Recommended tightening torque of most frequently applied nut and bolt connections are given in table (5.8).

Given values apply to non-lubricated steel bolts.

**TAB. 5.8 Tightening torque for nut and bolt connections**

THREAD METRIC	5.8 <sup>(1)</sup>	8.8 <sup>(1)</sup>	10.9 <sup>(1)</sup>
	M <sub>D</sub> [Nm]		
M10	37	49	72
M12	64	85	125
M14	100	135	200
M16	160	210	310
M20	300	425	610
M24	530	730	1 050
M27	820	1 150	1 650
M30	1 050	1 450	2 100

<sup>(1)</sup> – resistance class according to DIN ISO 898 standard, (M<sub>D</sub>) – tightening torque, (d) thread diameter

Hydraulic lines should be tightened with torque of 50 – 70 Nm.

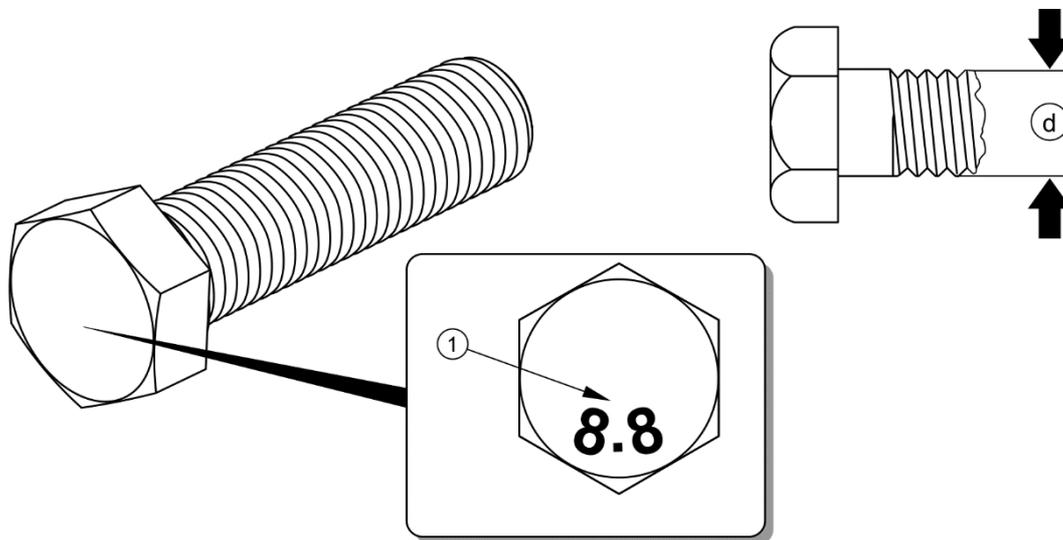

**FIG. 5.19 Bolt with metric thread**

*(1) bolt strength class, (d) thread diameter*

## 5.19 TROUBLESHOOTING

**TAB. 5.9**      **Faults and means of remedying them**

FAULT	CAUSE	REMEDY
Conveyor knocking	Excessive lengthening of conveyor chains. Improperly adjusted tension of conveyor chains.	Check tension of chains and adjust according to section 5.14.
Spreader unit is blocked	Excessive floor conveyor speed.	Reduce speed of floor conveyor and change conveyor movement direction.
	Adjusting shield is tilted excessively forward	Shift the adjusting shield to the rear
Problem with moving off	Brake system lines/line not connected.	Connect brake conduits.
	Damaged brake system connection lines.	Replace lines with new ones.
	Leaking connections.	Tighten, replace washers or seal set.
	Parking brake is applied.	Release parking brake.
Poor reliability of braking system	Insufficient pressure in system	Check pressure on tractor pressure gauge, wait till compressor fills tank to required pressure.
	Damaged air compressor in tractor	Repair or replace.
	Damaged brake valve in tractor.	Repair or replace.
	Leaking system conduits or connections.	Check system for tightness.
Noise in axle hubs	Excessive play in bearings	Check play and adjust if needed
	Damaged bearings.	Change bearing together with sealing ring.

FAULT	CAUSE	REMEDY
Excessive heating of axle hubs	Incorrectly adjusted main brake.	Regulate setting of expander arms
	Incorrectly adjusted parking brake.	Adjust tension of parking brake cables.
	Worn brake linings.	Change brake shoes.
Control system of the chain conveyor does not work	Interrupted oil flow.	Check degree of wear of connector plug. Set the tractor's control valve for pressure.
	Exchanged supply lines	Exchange the connectors.
Damaged PTO shaft	Excessive angular deviation during operation.	Use a wide-angle PTO shaft or disconnect the PTO when cornering.
	PTO shaft is too short or too long	Replace PTO shaft with a different one. Adjust the PTO shaft according to its Operator's Manual.

# NOTES

A series of horizontal dotted lines for writing notes.

# ANNEX A

## Tyre dimensions

MANURE SPREADER VERSION	TYRE DIMENSIONS
<b>N262</b>	550/60-22,5 163A8 <sup>(1)</sup>
	550/60-22,5 171A8 <sup>(1)</sup>
	600/55-22.5 169A8 <sup>(2)</sup>
<b>N262/1</b>	600/50-22,5 165A8 <sup>(2)</sup>
	600/55-22,5 165A8 <sup>(2)</sup>
	600/50-22,5; 165A8 <sup>(3)</sup>
	600/55-22,5; 169A8 <sup>(3)</sup>
	700/40-22,5; 166A8 <sup>(4)</sup>

<sup>(1)</sup> - Wheel disc 16.00x22.5; ET=0

<sup>(2)</sup> - Wheel disc 20.00x22.5; ET=-20

<sup>(3)</sup> - Wheel disc 20.00x22.5; ET=-40

<sup>(4)</sup> - Wheel disc 24.00x22.5; ET=-50

