



**PRONAR Sp. z o.o.**

17-210 NAREW, UL. MICKIEWICZA 101A, PODLASKIE PROVINCE

phone:	+48 085 681 63 29	+48 085 681 64 29
	+48 085 681 63 81	+48 085 681 63 82
fax:	+48 085 681 63 83	+48 085 682 71 10

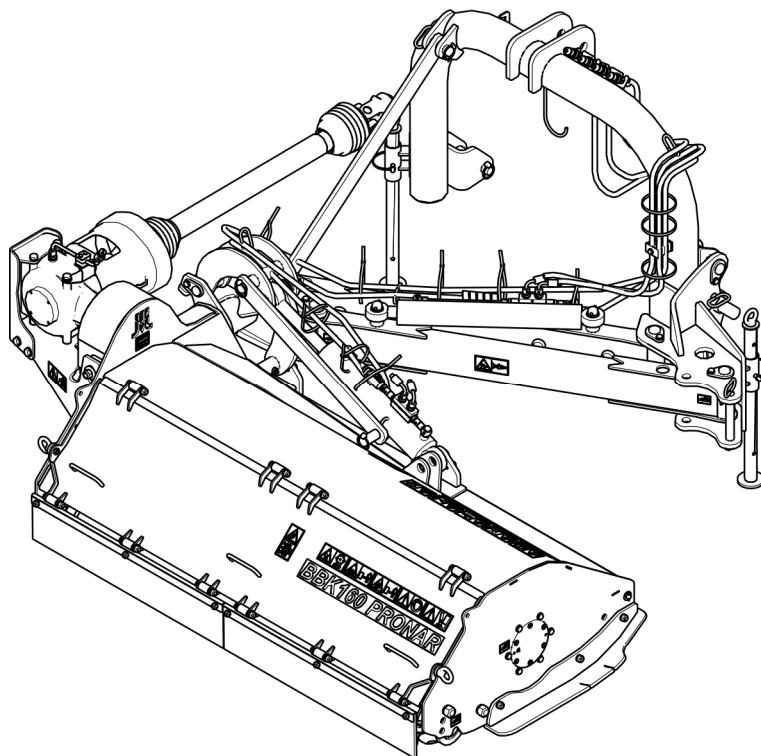
[www.pronar.pl](http://www.pronar.pl)

# OPERATOR'S MANUAL

## FLAIL MOWER

### PRONAR BBK160 PRONAR BBK180 PRONAR BBK200

TRANSLATION OF THE ORIGINAL COPY OF THE MANUAL



EDITION 1B-09-2014

PUBLICATION NO 349N-00000000-UM







# INTRODUCTION

Information contained herein is current at date of publication. As a result of improvements, some numerical values and illustrations contained in this publication may not correspond to the factual specification of the machine supplied to the user. The manufacturer reserves the right to introduce design changes in machines produced that facilitate operation and improve the quality of their work, without making minor amendments to this Operator's Manual.

This Operator's Manual is an integral part of the machine's documentation. Before using the machine, the user must carefully read this Operator's Manual and observe all recommendations. This guarantees safe operation and ensures malfunction free work of the machine. The machine is designed to meet obligatory standards, documents and legal regulations currently in force.

The manual describes the basic safety rules and operation of flail mowers PRONAR BBK160 / BBK180 / BBK200. If the information stated in the Operator's Manual needs clarification then the user should refer for assistance to the sale point where the machine was purchased or to the Manufacturer.

## MANUFACTURER'S ADDRESS:

*PRONAR Sp. z o.o.  
ul. Mickiewicza 101A  
17-210 Narew*

## CONTACT TELEPHONES

<i>+48 085 681 63 29</i>	<i>+48 085 681 64 29</i>
<i>+48 085 681 63 81</i>	<i>+48 085 681 63 82</i>

## SYMBOLS APPEARING IN THIS OPERATOR'S MANUAL

Information, descriptions of danger and precautions and also recommendations and prohibitions associated with user safety instructions are marked:



and also preceded by the word "**DANGER**". Failure to observe the instructions may endanger the machine operator's or other person's health or life.

Particularly important information and instructions, the observance of which is essential, are distinguished in the text by the sign:



and also preceded by the word "**ATTENTION**". Failure to observe the instructions may lead to damage to the machine as a result of improper operation, adjustment or use.

In order to focus the user's attention on the need to perform maintenance, the relevant section of the Operator's Manual is marked with the pictogram:



Additional tips and advice for machine operation are marked:



and also preceded by the word "**TIP**".

## DIRECTIONS USED IN THIS OPERATOR'S MANUAL

Left side – side to the left hand of the operator facing in the direction of machine's forward travel.

Right side – side to the right hand of the operator facing in the direction of machine's forward travel.





**PRONAR Sp. z o.o.**

ul. Mickiewicza 101 A  
17-210 Narew, Polska

tel./fax (+48 85) 681 63 29, 681 63 81, 681 63 82,  
681 63 84, 681 64 29

fax (+48 85) 681 63 83

http://www.pronar.pl

e-mail: pronar@pronar.pl

## EC DECLARATION OF CONFORMITY OF THE MACHINERY

PRONAR Sp. z o.o. declares with full responsibility, that the machine:

Description and identification of the machinery			
Generic denomination and function:	<b>Flail mower</b>		
Type:	<b>BBK160</b>	<b>BBK180</b>	<b>BBK200</b>
Model:	–	–	–
Serial number:			
Commercial name:	<b>Flail mower PRONAR BBK160</b> <b>Flail mower PRONAR BBK180</b> <b>Flail mower PRONAR BBK200</b>		

to which this declaration relates, fulfills all the relevant provisions of the Directive **2006/42/EC** of The European Parliament and of The Council of 17 May 2006 on machinery, and amending Directive 95/16/EC (Official Journal of the EU, L 157/24 of 09.06.2006).

The person authorized to compile the technical file is the Head of Research and Development Department at PRONAR Sp. z o.o., 17-210 Narew, ul. Mickiewicza 101A, Poland.

This declaration relates exclusively to the machinery in the state in which it was placed on the market, and excludes components which are added and/or operations carried out subsequently by the final user.

Narew, the 18 PAŹ. 2012

*Place and date*

Z-C.A. DYREKTORA  
d/s. technicznych  
członek zarządu

*Roman Omelianiuk*

*Full name of the empowered person  
position, signature*





# TABLE OF CONTENTS

<b>1</b>	<b>BASIC INFORMATION</b>	<b>1.1</b>
1.1	IDENTIFICATION	1.2
1.2	PROPER USE	1.3
1.3	EQUIPMENT	1.5
1.4	TERMS & CONDITIONS OF WARRANTY	1.5
1.5	TRANSPORT	1.6
1.6	ENVIRONMENTAL HAZARDS	1.9
1.7	WITHDRAWAL FROM USE	1.10
<b>2</b>	<b>SAFETY ADVICE</b>	<b>2.1</b>
2.1	BASIC SAFETY RULES	2.2
2.1.1	USE OF MACHINE	2.2
2.1.2	LINKING AND DISCONNECTING FROM TRACTOR	2.3
2.1.3	HYDRAULIC SYSTEM	2.3
2.1.4	TRANSPORTING THE MACHINE	2.4
2.1.5	MAINTENANCE	2.5
2.1.6	WORK OF MOWER	2.6
2.1.7	OPERATION OF PTO SHAFT	2.7
2.2	DESCRIPTION OF MINIMAL RISK	2.8
2.3	INFORMATION AND WARNING DECALS	2.9
<b>3</b>	<b>DESIGN AND OPERATION</b>	<b>3.1</b>
3.1	TECHNICAL SPECIFICATION	3.2
3.2	GENERAL DESIGN	3.4
3.3	LINKAGE	3.5
3.4	HYDRAULIC SYSTEM	3.6

3.5 DRIVE TRANSMISSION	3.7
3.6 CUTTING UNIT	3.8
<b>4 CORRECT USE</b>	<b>4.1</b>
4.1 PREPARING FOR WORK	4.2
4.2 CHECKING TECHNICAL CONDITION	4.5
4.3 HITCHING TO TRACTOR	4.6
4.3.1 HITCHING TO THE TRACTOR REAR THREE-POINT LINKAGE	4.6
4.4 TRANSPORTING THE MACHINE	4.8
4.5 SETTING AND MOWING	4.10
4.5.1 SETTING THE MOWER IN WORKING POSITION	4.10
4.5.2 SETTING CUTTING HEIGHT	4.11
4.5.3 CONNECTING DRIVE SHAFT	4.12
4.5.4 MOWING	4.14
4.5.5 REMOVING BLOCKAGES	4.15
4.6 DISCONNECTING FROM TRACTOR	4.16
<b>5 MAINTENANCE</b>	<b>5.1</b>
5.1 INSPECTION AND DISASSEMBLY OF SAFETY GUARDS	5.2
5.2 CHECKING AND REPLACING FLAIL BLADES	5.5
5.3 DRIVE SYSTEM MAINTENANCE	5.7
5.4 HYDRAULIC SYSTEM OPERATION	5.11
5.5 STORAGE	5.13
5.6 LUBRICATION	5.14
5.7 TIGHTENING TORQUE FOR NUT AND BOLT CONNECTIONS	5.17
5.8 TROUBLESHOOTING	5.18

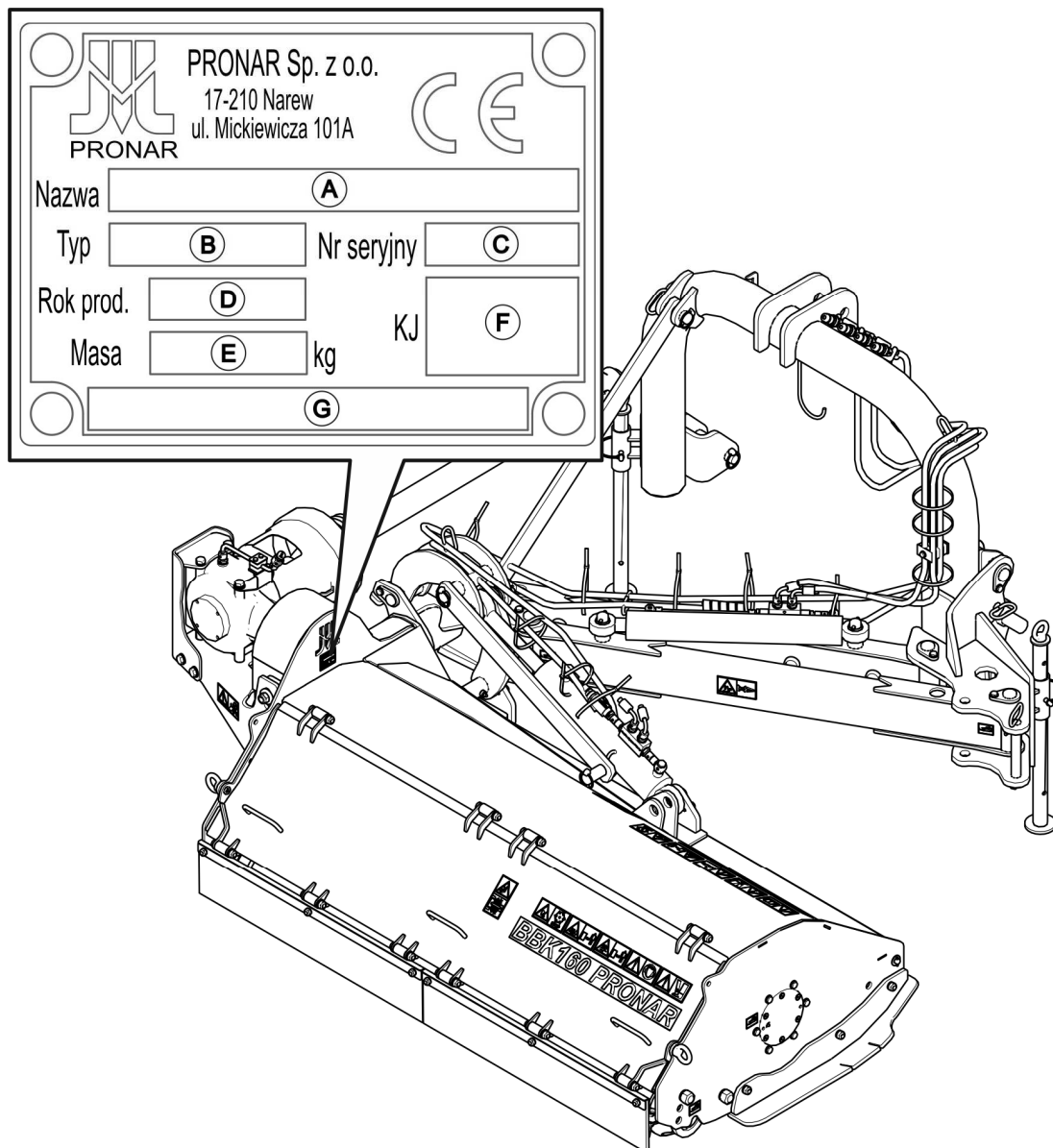
***SECTION***

**1**

---

**BASIC INFORMATION**

## 1.1 IDENTIFICATION



**FIG. 1.1** Location of the data plate

PRONAR BBK160 / BBK180 / BBK200 flail mowers are marked with the data plate located on the cutting unit housing. When buying the machine check that the serial numbers on the machine agree with the number written in the *WARRANTY BOOK*, in the sales documents and in the *OPERATOR'S MANUAL*.

The meanings of the individual fields found on the data plate (FIG. 1.1) are presented in the table below:

A - machine name,                      B - machine type/symbol,  
C – serial number,                      D – year of manufacture,  
E - gross weight [kg],                      F – Quality control stamp,  
G – machine name, name extension.

## 1.2 PROPER USE

PRONAR BBK160 / BBK180 / BBK200 rear-lateral flail-mowers are constructed according to current safety requirements and engineering standards.

PRONAR rear-lateral flail-mowers are designed for the maintenance of municipal infrastructure, urban greenery, orchards and wooded areas and for agricultural works. These machines are used for mowing and breaking up weeds, bushes and grass in undeveloped areas, on road shoulders, embankments, in drainage ditches, water channels and for chopping cut tree branches (up to 10 cm in diameter). They are also used for meadow reclamation in undeveloped areas to leave swath as well as for disintegrating post-cultivation corn and tobacco residues (stalks) on fields. Flail mowers are designed to mow and break up and evenly scatter the material across the mown area, which leaves natural swath and allows mineralization of plant debris and re-introducing nutrients into the soil.

Transporting people, animals or other materials is forbidden and regarded as contrary to the intended purpose. During the use of the machine comply with all road traffic regulations and transport regulations in force in the given country, and any breach of these regulations is regarded by the Manufacturer as use contrary to its intended purpose.

### **IMPORTANT!**



The mower must not be used for purposes other than those for which it is intended, in particular:

- for transporting people and animals,
- for transport of whatever materials or objects.

Using it as intended involves all actions connected with the safe and proper operation and maintenance of the machine. In connection with this the user is obliged to:

- carefully read the *OPERATOR'S MANUAL* and comply with its recommendations,
- understand the machine's operating principle and how to operate it safely and correctly,
- adhere to the established maintenance and adjustment plans,
- comply with general safety regulations while working,
- prevent accidents,
- comply with the road traffic regulations and transport regulations in force in a given country, in which the machine is used,
- carefully read the Operator's Manual and comply with its recommendations,

**TAB. 1.1 Agricultural tractor's requirements**

CONTENTS	UNIT	REQUIREMENTS
<b>Hydraulic system</b>		
Hydraulic oil	-	HL 32
Pressure rating of the system	MPa	16
Number of hydraulic sockets	item	4 sockets (2 double acting sections including one "floating" section)
<b>Implement suspension system (TPL - three-point linkage)</b>		
Rear three-point linkage	-	Category II and III according to ISO 730-1
<b>Power take-off shaft (PTO)</b>		
Rotation speed	RPM	540
Number of splines on PTO shaft	item	6
Rotation direction	-	clockwise
<b>Other requirements</b>		
Minimum power		
- BBK160	hp	50
- BBK180	hp	60
- BBK200	hp	70

The mower may only be used by persons, who:

- are familiar with the contents of this publication and with the contents of the agricultural tractor Operator's Manual,
- have been trained in mower service and safe operation,
- have the required authorisation to drive and are familiar with the road traffic regulations and transport regulations.

## 1.3 EQUIPMENT

**TAB. 1.2 Equipment for PRONAR BBK160 / BBK180 / BBK200 flail mowers**

EQUIPMENT	STANDARD			OPTION
	BBK160	BBK180	BBK200	
Operator's Manual	•	•	•	
Warranty book	•	•	•	
Wide angle PTO shaft:				
- „Bondioli&Pavesi” DS6N178CEKR7K01	•	•	-	
- „Bondioli&Pavesi” DH8N178CEKR7K01	-	-	•	

## 1.4 TERMS & CONDITIONS OF WARRANTY

PRONAR Sp. z o.o., Narew guarantees the reliable operation of the machine when it is used according to its intended purpose as described in the *OPERATOR'S MANUAL*. Defects discovered during the warranty period will be removed by the Warranty Service. The repair period is specified in the *WARRANTY BOOK*.

The warranty does not apply to those parts and sub-assemblies of the machine, which are subject to wear in normal usage conditions, regardless of the warranty period. Consumables include the following parts/sub-assemblies:

- flail blades,
- rubber shields,
- bearings.

The warranty service only applies to factory defects and mechanical damage that is not due to the user's fault.

In the event of damage arising from:

- mechanical damage which is the user's fault, caused by road accidents,
- by inappropriate use, adjustment or maintenance, use of the machine for purposes other than those for which it is intended,
- use of damaged machine,
- repairs carried out by unauthorised persons, improperly carried out repairs,
- making unauthorised alterations to machine design,

the user will lose the right to warranty service.



### TIP

**Demand that the seller carefully and precisely fills out the Warranty Book and warranty repair coupons. A missing date of purchase or sale point stamp, may make the user ineligible for any warranty repair or refund.**

The user is obliged to report immediately on noticing any wear in the paint coating or traces of corrosion, and to have the faults rectified whether they are covered by the warranty or not. For detailed Terms & Conditions of Warranty, please refer to the WARRANTY BOOK attached to each machine.

Modification of the mower without the written consent of the Manufacturer is forbidden. In particular, do NOT weld, drill holes in, cut or heat the main structural elements of the machine, which have a direct impact on the machine operation safety.

## 1.5 TRANSPORT

The mower is ready for sale completely assembled and does not require packing. Packing is only required for the machine's technical documentation and any extra fittings.

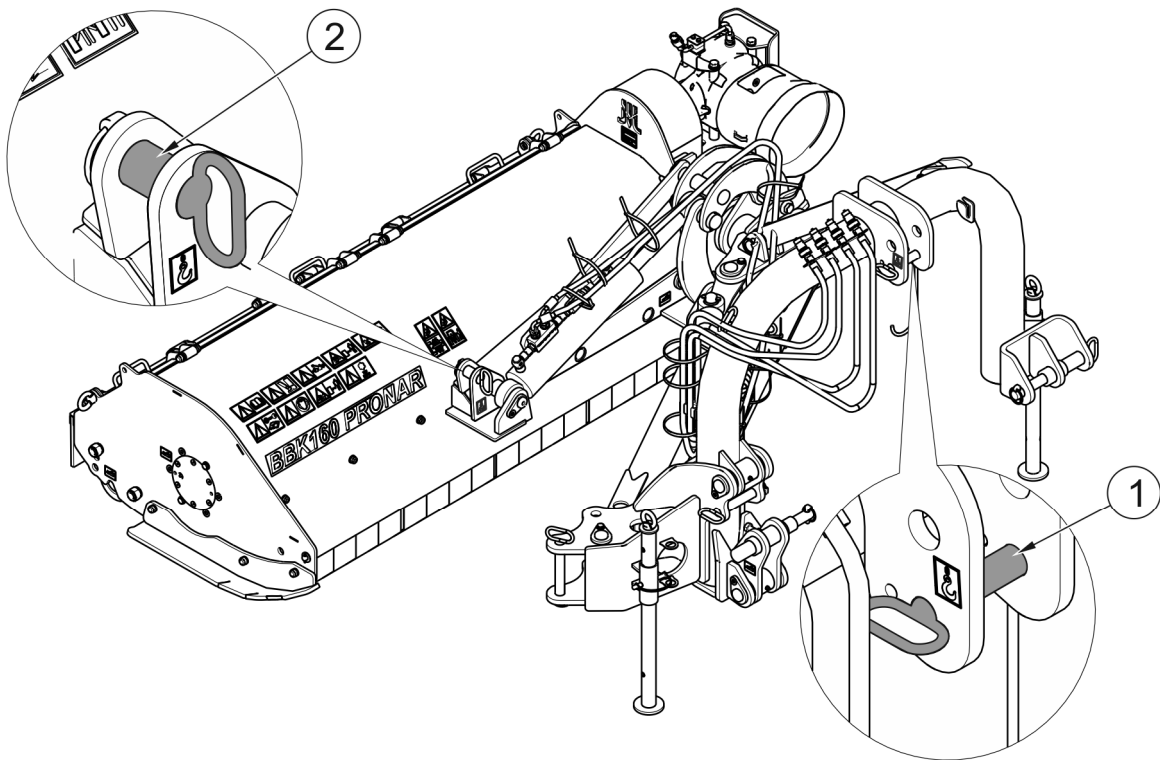
Delivery is either by transport on a vehicle or independently, after being attached to a tractor. Transport of the mower is permissible connected to a tractor provided the tractor's driver familiarises himself with the machine's Operator's Manual and particularly with information concerning safety and principles of connection and transport of mower on public roads. Do NOT drive the tractor with mower connected when visibility is limited.



**IMPORTANT!**

Before transporting independently, the tractor driver must carefully read this operator's manual and observe its recommendations. When being transported on a motor vehicle the mower must be mounted on the vehicle's platform in accordance with the transport safety requirements. The driver of the vehicle should take particular care while driving. This is due to the vehicle's centre of gravity shifting upwards when loaded with the machine.

When loading and unloading the mower, comply with the general principles of workplace health and safety for reloading work. Persons operating reloading equipment must have the qualifications required to operate these machines.



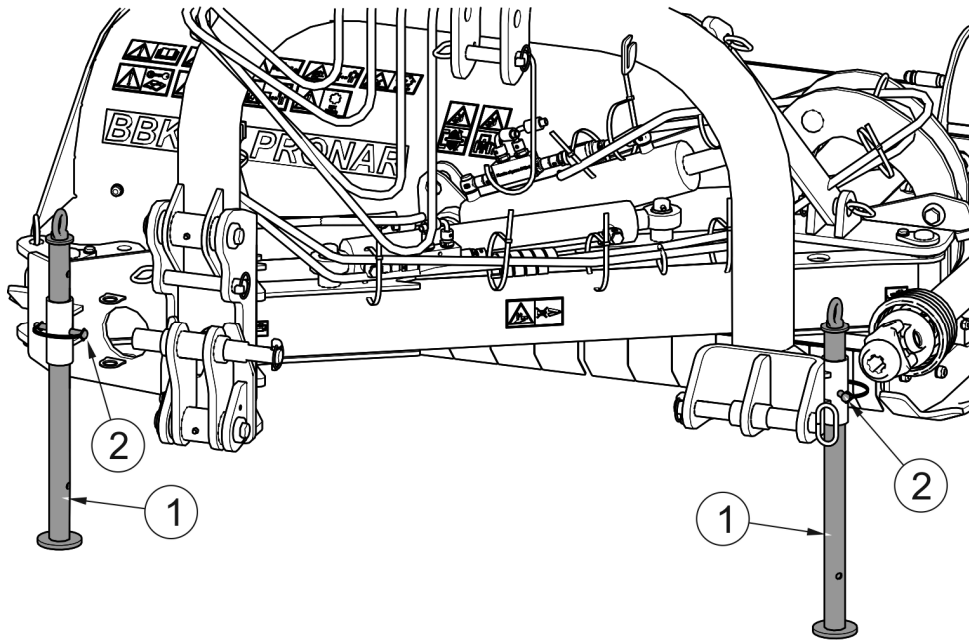
**FIG. 1.2** Transport lugs

(1)- central connection pin (hitch pin); (2)- cylinder interlock pin

The mower should be attached to lifting equipment in places designed for this purpose shown in Figure (FIG. 1.2), i.e. to central connection pin and cylinder interlock pin.

**IMPORTANT!**

Do NOT secure lifting slings or any types of securing elements to hydraulic cylinders.



**FIG. 1.3 Mower correctly secured with a parking stand during loading**

(1)- parking stand; (2)- securing pin



### TIP

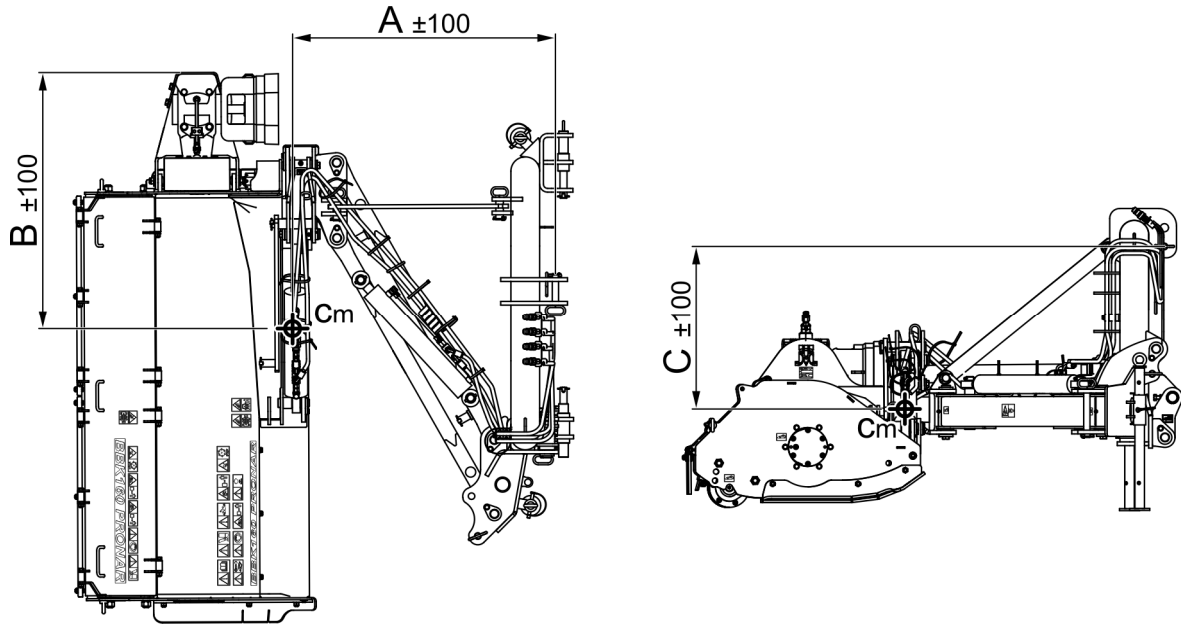
The mower must be set in park position during unloading with lifting equipment. Parking stand should be lowered and secured with a pin (FIGURE 1.3).

The machine should be attached firmly to the platform of the vehicle using straps or chains fitted with a tightening mechanism. The fastening equipment used must have a valid safety certificate. Exercise particular caution when lifting the machine. To keep lifted machine in the correct direction it is recommended to apply additional guy cables. During the loading work particular care should be taken not to damage paint coating.



### IMPORTANT!

Nobody may be in the manoeuvring zone during transferring mower to other form of transport.



**FIG. 1.4 Centre of gravity of the mower**

**TAB. 1.3 Centre of gravity**

Dimension (FIGURE 1.4)	Unit	Mower model		
		BBK160	BBK180	BBK200
A	mm	1 030	1 050	1 065
B	mm	1 030	1 090	1,150
C	mm	655	660	665

## 1.6 ENVIRONMENTAL HAZARDS

A hydraulic oil leak constitutes a direct threat to the natural environment owing to its limited biodegradability. While carrying out maintenance and repair work which involves the risk of an oil leak, this work should take place on an oil resistant floor or surface. In the event of oil leaking into the environment, first of all contain the source of the leak, and then collect the leaked oil using available means. Remaining oil should be collected using sorbents, or by mixing the oil with sand, sawdust or other absorbent materials. The oil pollution, once gathered up, should be kept in a sealed, marked, hydrocarbon resistant container, and then passed on to the appropriate oil waste recycling centre. The container should be kept away from heat sources, flammable materials and food.

Oil, which has been used up or is unsuitable for further use owing to a loss of its properties should be stored in its original packaging in the conditions described above.

## 1.7 WITHDRAWAL FROM USE

In the event of decision by the user to withdraw the machine from use, comply with the regulations in force in the given country concerning withdrawal from use and recycling of machines withdrawn from use.

Before proceeding to dismantle equipment, oil shall be completely removed from hydraulic system and transmission. Locations of drain plugs and method for draining oil are described in SECTION 5.

When spare parts are changed, worn out or damaged parts should be taken to a collection point for recyclable raw materials. Waste oil and also rubber and plastic elements should be taken to establishments undertaking the utilisation of such waste.



### **IMPORTANT!**

**During dismantling personal protection equipment shall be used i.e. protective clothing, boots, gloves and protective goggles etc.**

**Avoid contact of skin with oil. Do not allow used oil to spill.**

**SECTION**

**2**

---

**SAFETY ADVICE**

## 2.1 BASIC SAFETY RULES

### 2.1.1 USE OF MACHINE

- Before using the machine, the user must carefully read this Operator's Manual and the *WARRANTY BOOK*. When operating the machine, the operator must comply with the recommendations.
- The mower may only be used and operated by persons qualified to drive agricultural tractors and agricultural machines and trained in the use of the machine. Mower can be operated by a single person only.
- If the information stated in the Operator's Manual is difficult to understand, contact a seller, who runs an authorised technical service on behalf of the manufacturer, or contact the manufacturer directly.
- Careless and improper use and operation of the machine, and non-compliance with the recommendations given in this operator's manual is dangerous to your health.
- Be aware of the existence of a minimal risk, and for this reason the fundamental basis for using this machine should be the application of safety rules and sensible behaviour.
- The machine must never be used by persons, who are not authorised to drive agricultural tractors, including children and people under the influence of alcohol or other drugs.
- Non-compliance with the safety rules of this Operator's Manual can be dangerous to the health and life of the operator and others.
- The machine must not be used for purposes other than those for which it is intended. Anyone who uses the mower other than the way intended takes full responsibility for himself for any consequences of this potentially improper use. Use of the machine for purposes other than those for which it is intended by the Manufacturer may invalidate the warranty.
- The machine may only be used when all the safety guards and other protective elements are technically sound and correctly positioned. In the event of loss or destruction of the safety guards, they must be replaced with new ones.

- In order to limit occupational risks associated with exposure to noise during mower operation use individual protection (ear protectors). In order to reduce the level of noise during work the tractor cab window and door should be closed.

### **2.1.2 LINKING AND DISCONNECTING FROM TRACTOR**

- Do NOT link the mower to a tractor, if hydraulic oil applied in both machines are of different types, or if the three point linkage system of the mower is not compatible with the category of the linkage system of the tractor.
- To attach the machine to the tractor only the rear three point linkage may be used. After mounting the machine, check the safeguards. Carefully read the tractor Operator's Manual.
- To mount machine on tractor use only genuine pins and safeguard cotter pins.
- The agricultural tractor to which the mower will be coupled must be technically reliable and must fulfil the requirements of mower Manufacturer.
- Be especially careful when hitching the machine.
- During hitching there must be nobody between the mower and the tractor.
- Do NOT unhitch the mower from the tractor if the cutting system is raised. Exercise caution when disconnecting mower.
- Coupling and uncoupling may only take place when the mower and the tractor are switched off.
- Mower uncoupled from the tractor must be supported by means of supports secured with pins.

### **2.1.3 HYDRAULIC SYSTEM**

- The hydraulic system is under high pressure when operating.
- Regularly check the technical condition of the connections and the hydraulic lines. There must be no oil leaks.
- In the event of malfunction of the hydraulic system, the machine shall be disconnected from use until the malfunction is corrected.

- When connecting the hydraulic lines to the tractor, make sure that the tractor hydraulic system and mower are not under pressure. If necessary reduce residual pressure in the system.
- In the event of injuries being caused by pressurised hydraulic oil, contact a doctor immediately. Hydraulic oil may find its way under the skin and cause infections. In the event of contact of oil with eye, rinse with large quantity of water and in the event of the occurrence of irritation consult a doctor. In the event of contact of oil with skin wash the area of contact with water and soap. Do NOT apply organic solvents (petrol, kerosene).
- Use the hydraulic oil recommended by the Manufacturer. Never mix two types of oil.
- After changing the hydraulic oil, the used oil should be properly disposed of. Used oil or oil, which has lost its properties, should be stored in original containers or replacement containers resistant to action of hydrocarbons. Replacement containers must be clearly marked and appropriately stored.
- Do not store hydraulic oil in packaging designed for storing food or foodstuffs.
- Rubber hydraulic lines must be replaced every 4 years regardless of their technical condition.
- Repair and replacement of hydraulic system elements should be entrusted to the appropriately qualified persons.

#### **2.1.4 TRANSPORTING THE MACHINE**

- When driving on public roads, comply with the road traffic regulations. in force in the country, in which the machine is used.
- Do not exceed the permitted speed arising from road conditions and design limitations. Adjust travel speed to the prevailing road conditions and other limitations arising from road traffic regulations limits.
- Before beginning travel, the mower must be placed in transport position and raised using the rear three-point linkage system.
- Do NOT leave machine raised and unsecured while the tractor is parked. When parked, the machine should be lowered.



- Do not transport the machine with the cutting assembly set in the working position.
- During transport disconnect PTO shaft from tractor.
- The mower may not be used or transported in conditions of limited visibility.
- Do NOT ride on the machine or transport any materials on it.
- Before using the machine always check its technical condition, especially in terms of safety. In particular, check the technical condition of the hitch system, the cutting system and elements connecting hydraulic system.
- Reckless driving and excessive speed may cause accidents.

### **2.1.5 MAINTENANCE**

- During the warranty period, any repairs may only be carried out by Warranty Service authorised by the manufacturer. It is recommended that necessary repairs to machine should be undertaken by specialised workshops.
- In the event of any fault or damage whatsoever, do not use the mower until the fault has been corrected.
- During work use the proper, close-fitting protective clothing, gloves and appropriate tools. When working on hydraulic systems it is recommended to use oil resistant gloves and protective goggles.
- Any modification to the mower frees the manufacturer (PRONAR Sp. z o.o. in Narew) from any responsibility for damage or detriment to health which may arise as a result.
- Before undertaking any work on the mower disconnect tractor engine and wait until all rotating parts come to a stop.
- Regularly check the technical condition of the safety devices and correct tightening of bolt connections.
- Regularly perform service inspections of machine as recommended by the Manufacturer.
- Do NOT perform service or repair work under raised and unsupported machine.
- Before beginning repair works on hydraulic systems, reduce oil pressure.

- Servicing and repair work should be carried out in line with the general principles of workplace health and safety. In the event of injury, the wound must be immediately cleaned and disinfected. In the event of more serious injuries, seek a doctor's advice.
- Repair, maintenance and cleaning work should be carried out with the tractor's engine turned off and the ignition key removed. Immobilise tractor with parking brake. Ensure that unauthorised persons do not have access to the tractor cab.
- Should it be necessary to change individual parts, use only original parts. Non-adherence to these requirements may put the user and other people's health and life at risk, and also damage the machine and invalidate the warranty.
- Regularly check technical condition and mounting of all guards and protective elements.
- In the event of work requiring the mower to be raised, use properly certified hydraulic or mechanical lifts for this purpose. After lifting the machine, stable and durable supports must also be used. Do NOT carry out work under a machine, which has only been raised with the three point linkage.
- The machine must not be supported using fragile elements (bricks or concrete blocks etc.).
- After completing work associated with lubrication, remove excess oil or grease.
- Damaged, missing or worn blades must be replaced in pairs (simultaneously with a blade located on the opposite side of the shaft axis) in order to maintain the balance of the flail shaft.
- In order to reduce the danger of fire the machine must be kept in a clean condition.

### **2.1.6 WORK OF MOWER**

- Before lowering or lifting the mower mounted on the three-point linkage, make sure there are no bystanders, especially children, near the machine.
- Before starting mower drive, the cutting assembly must be in working position.
- Before starting the mower make sure that there are no bystanders (especially children) or animals in the danger zone. The machine operator is obliged to ensure proper visibility of the machine and the working area.

- Mowing should begin after reaching nominal PTO RPM of 540 rpm. Do NOT overload shaft and mower and also do NOT engage the clutch suddenly.
- During cutting do NOT use PTO revolution speed greater than 540 rpm.
- When mowing on the edges of streets, public roads, on stony ground there is a risk that thrown out stones and foreign bodies may pose a risk to bystanders and other vehicle passing by.
- Do NOT leave the tractor cab, when the machine drive is engaged.
- Do NOT stand within the mower's working zone.
- Do NOT approach cutting unit guards until the rotating cutting parts come to a complete standstill.
- Do NOT operate mower while reversing. While reversing lift machine.
- Keep a safe distance from electric power lines during travel with raised cutting assembly.

### **2.1.7 OPERATION OF PTO SHAFT**

- While reversing and during turns, the PTO drive must be disengaged.
- The machine may only be connected to the tractor by appropriately selected PTO shaft recommended by the Manufacturer.
- The PTO shaft has markings on the casing, indicating, which end of the shaft shall be connected to the tractor.
- Never use a damaged PTO shaft, it may cause an accident. A damaged shaft must be repaired or replaced.
- Disconnect the drive shaft each time when it is not necessary to drive the machine.
- The chains preventing the shaft cover from turning while the shaft is working, shall be secured to a fixed element of machine structure.
- Do NOT use the securing chains to support the shaft while machine is parked or when transporting the machine.
- Before using the machine, the user should thoroughly acquaint himself with the PTO shaft Operator's Manual and adhere to the recommendations contained in it.

- The drive shaft must be equipped with a cover. Do NOT use the shaft with damaged or missing guards.
- After connecting shaft ensure that it is correctly and safely connected to the tractor and to the mower.
- Before starting the machine make sure that there are no bystanders (especially children) in the danger zone. The machine operator is obliged to ensure proper visibility of the machine and the working area.
- Before starting PTO shaft make certain that the PTO rotation direction is correct.
- Before disconnecting the shaft, turn off the tractor engine and remove the key from the ignition.
- Do NOT wear loose clothing, straps or whatever that may become wrapped round the rotating drive shaft. Contact with rotating PTO shaft may cause severe injuries.
- Do NOT go over and under the shaft or stand on it equally during work as also when the machine is parked.
- Before starting the PTO shaft, adjust its length according to the Operator's Manual of the PTO shaft.

## 2.2 DESCRIPTION OF MINIMAL RISK

Pronar Sp. z o. o. in Narew has made every effort to eliminate the risk of accidents. There is, however, a certain minimal risk, which could lead to an accident, and this is connected mainly with the actions described below:

- using the machine for purposes other than those for which it is intended,
- being between the tractor and the machine while the engine is running and when the machine is being attached,
- being on the machine while the engine is running,
- operating the mower with removed or faulty safety guards,
- not maintaining safe distance from the danger zone or being within the zones while the machine is operating,
- operation of the machine by unauthorised persons or persons under the influence of alcohol or other intoxicating substances,

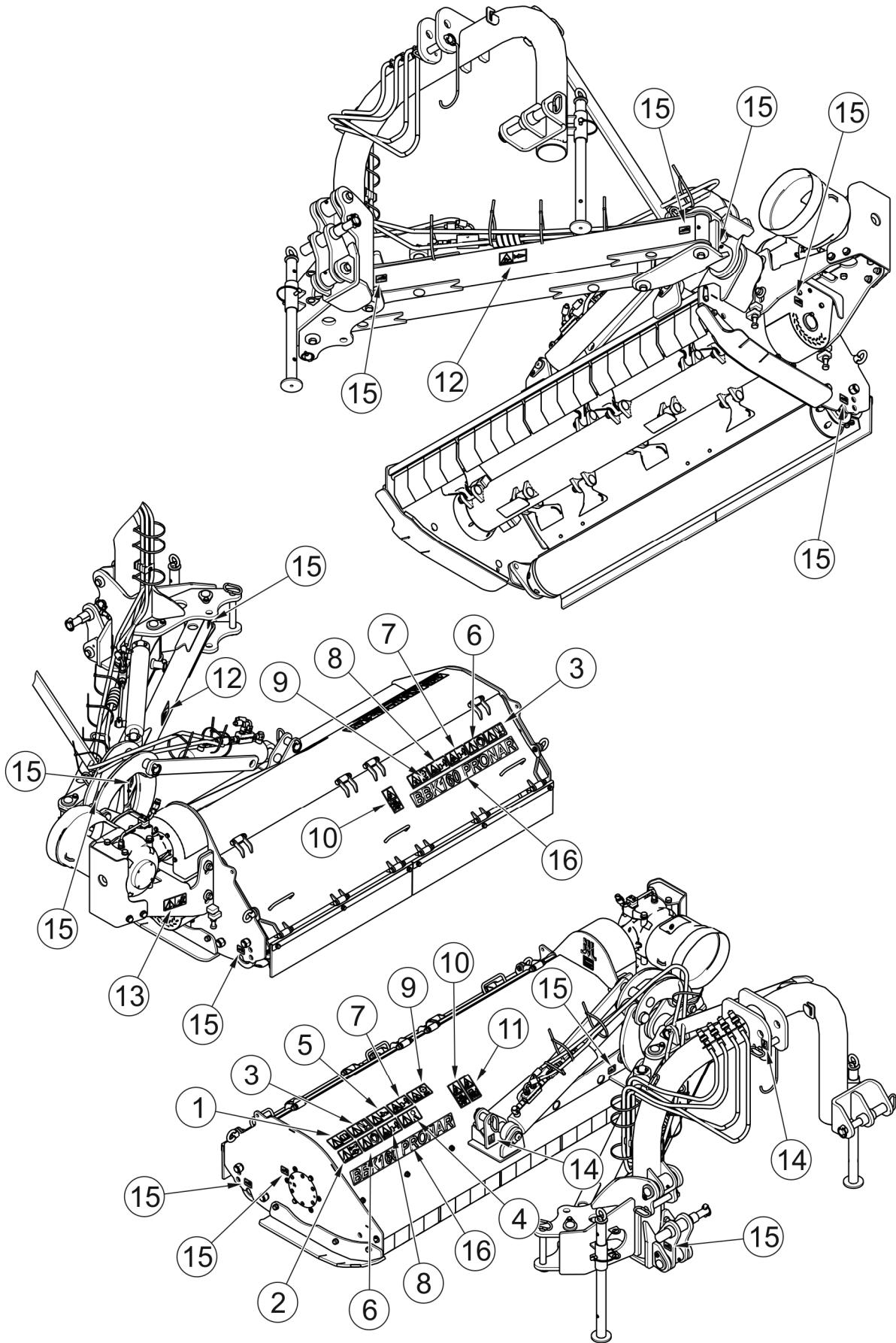
- cleaning, maintenance and technical checks when tractor is connected and engine is running;

The minimal risk may be kept to a minimum by following the recommendations below:

- prudent and unhurried operation of the machine,
- sensible application of the remarks and recommendations stated in the Operator's Manual,
- carrying out repair and maintenance work in line with operating safety rules,
- carrying out repair and maintenance work by persons trained to do so,
- using close fitting protective clothing,
- ensuring unauthorised persons have no access to the machine, especially children,
- maintaining safe distance from forbidden or dangerous places
- a ban on being on the machine when it is operating,

## **2.3 INFORMATION AND WARNING DECALS**


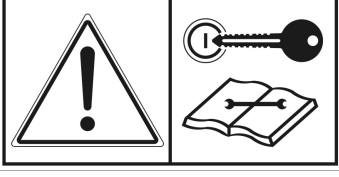




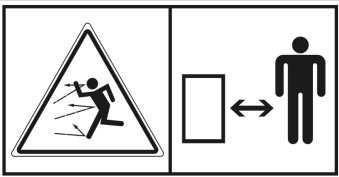
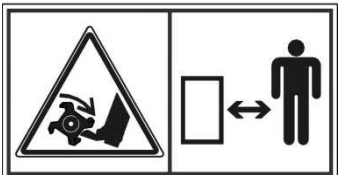
The mower is labelled with the information and warning decals mentioned in table (2.1). The symbols are positioned as presented in figure (2.1). Throughout the time it is in use, the user of the machine is obliged to take care that notices and warning and information symbols located on the machine are clear and legible. In the event of their destruction, they must be replaced with new ones. Safety decals are available from your PRONAR dealer or directly from PRONAR customer service. New assemblies, changed during repair, must be labelled once again with the appropriate safety signs. During cleaning do not use solvents, which may damage label covering and do not direct strong water jet at machine.




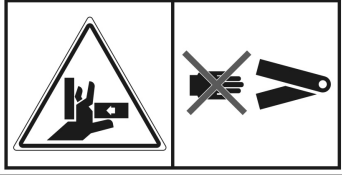





**FIG. 2.1** Locations of information and warning decals.

*Meaning of symbols (TAB. 2.1)*

TAB. 2.1 Information and warning decals

ITEM	DECAL	MEANING
1		Before starting work, carefully read the Operator's Manual.
2		Before beginning servicing or repairs, switch off engine and remove key from ignition
3		Danger of crushing toes or feet.
4		Maximum allowable PTO shaft rotation speed is 540 rpm.
5		Danger associated with the rotating PTO shaft.
6		High noise level warning.
7		Thrown out objects, endanger the whole body. Keep a safe distance from the operating machine.
8		Risk of injury to foot or leg. Keep a safe distance.

ITEM	DECAL	MEANING
9		<p>Do not touch any rotating elements until they come to a complete standstill.</p>
10		<p>Risk of injury when machine is being arranged in transport or working position.</p>
11		<p>Do not stand behind the tractor while lifting arm is operated.</p>
12		<p>Do not reach into crushing space because elements may move. Danger of crushing hands or fingers.</p>
13		<p>Attention! Belt transmission, take extreme care.</p>
14		<p>Transport lug points marking.</p>
15		<p>Lubrication points</p>
16		<p>Machine type.</p>



ITEM	DECAL	MEANING
	<p data-bbox="288 297 1002 365"><b>BBK160 PRONAR</b></p> <p data-bbox="628 383 660 405">or</p> <p data-bbox="288 434 1002 501"><b>BBK180 PRONAR</b></p> <p data-bbox="628 528 660 551">or</p> <p data-bbox="288 580 1002 647"><b>BBK200 PRONAR</b></p>	

*Numbers in the item column correspond to decals (FIG. 2.1)*



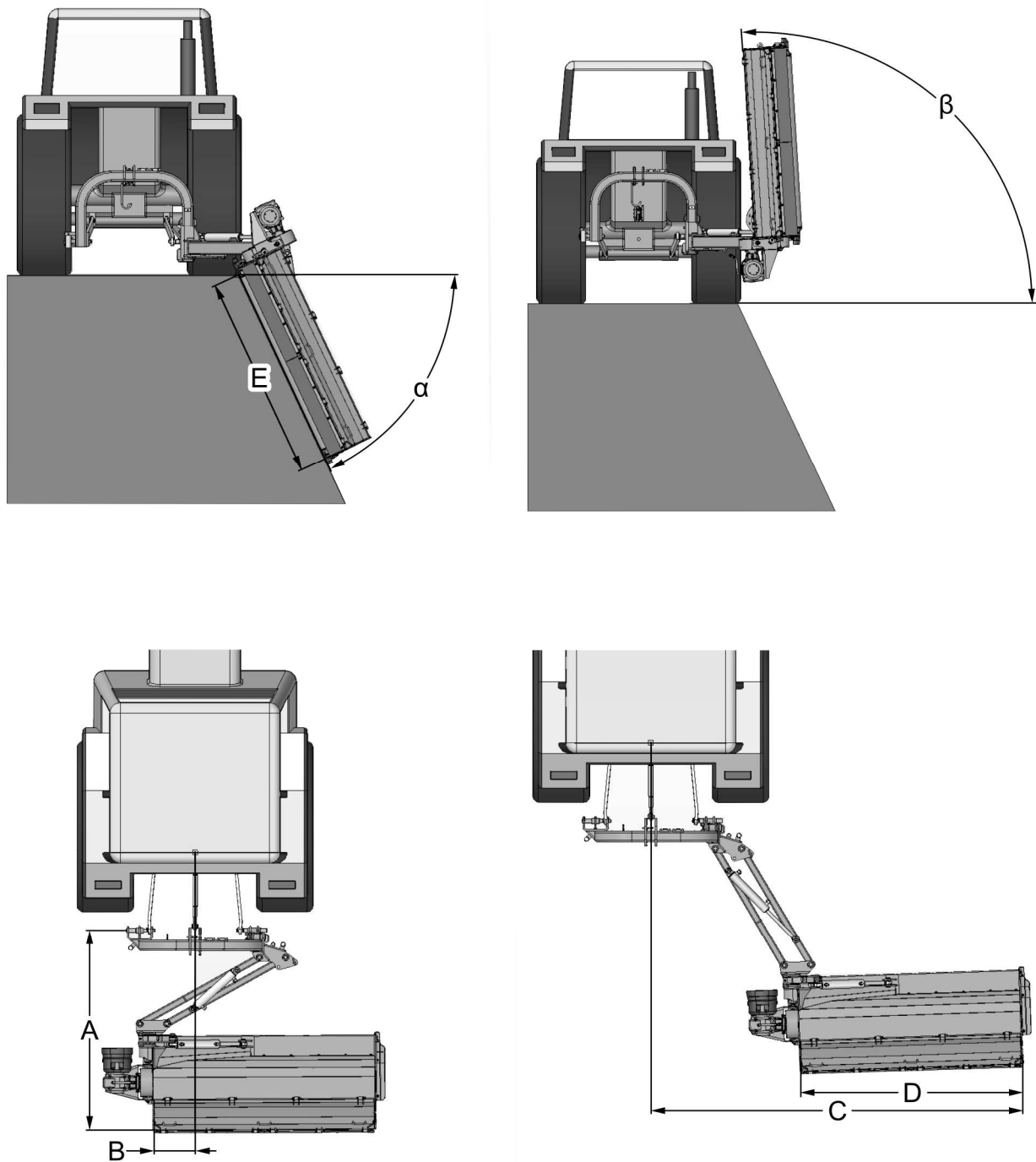
*SECTION*

**3**

---

**DESIGN AND  
OPERATION**

### 3.1 TECHNICAL SPECIFICATION



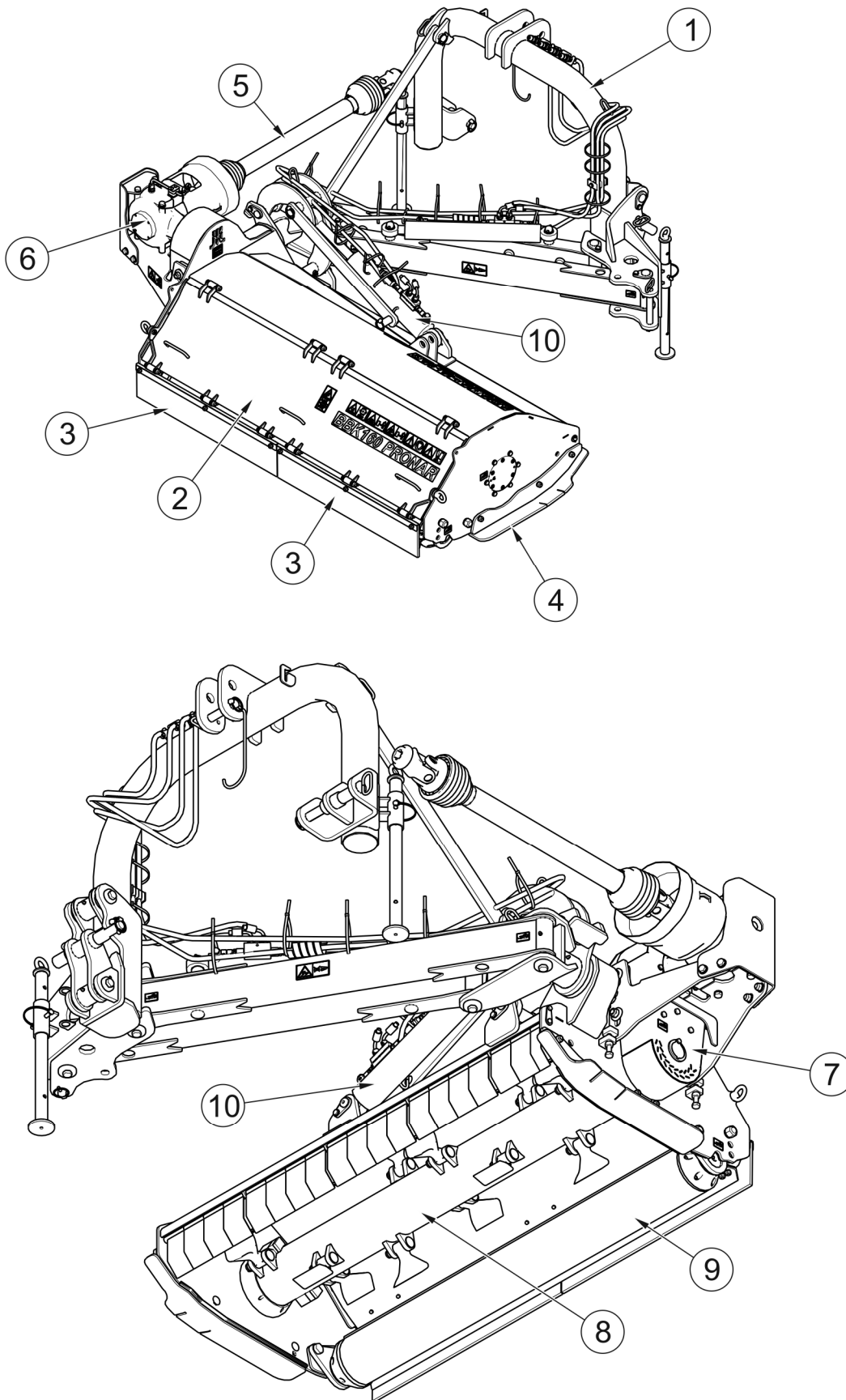
**FIG. 3.1 Working range and angle of the mower**

*Meaning of symbols (TABLE 3.1)*

**TAB. 3.1 BASIC TECHNICAL SPECIFICATION**

	Unit	BBK160	BBK180	BBK200	
<b>Dimensions</b>					
Total length in transport setting	mm	1 900			
Width in transport setting:	mm	1 660			
Height in transport setting:	mm	2 160	2 380	2 600	
<b>Technical specification</b>					
Cutting width	mm	1 600	1 800	2 000	
Horizontal shift of the mower (hydraulic shift)	mm	1 720			
Productivity	ha/h	~1,0	~1,3	~1,6	
Tare weight	kg	740	795	840	
Minimum power demand	hp	50	60	70	
Maximum PTO speed	RPM	540			
Linkage: - rear three-point linkage	-	cat. II and III according to ISO 730-1			
Flail shaft diameter	mm	Ø160			
Tracing shaft diameter	mm	Ø160			
Number of flail blades	item	14	16	18	
Rotation speed of flail shaft	RPM	2 450			
Mower working range	A	mm	1 890		
	B		390		
	C		3 040	3 260	3 480
	D		1 620	1 840	2 060
	E		1 610	1 830	2 050
Working angle – downwards	$\alpha$	angles	65		
Working angle – upwards	$\beta$	angles	94		

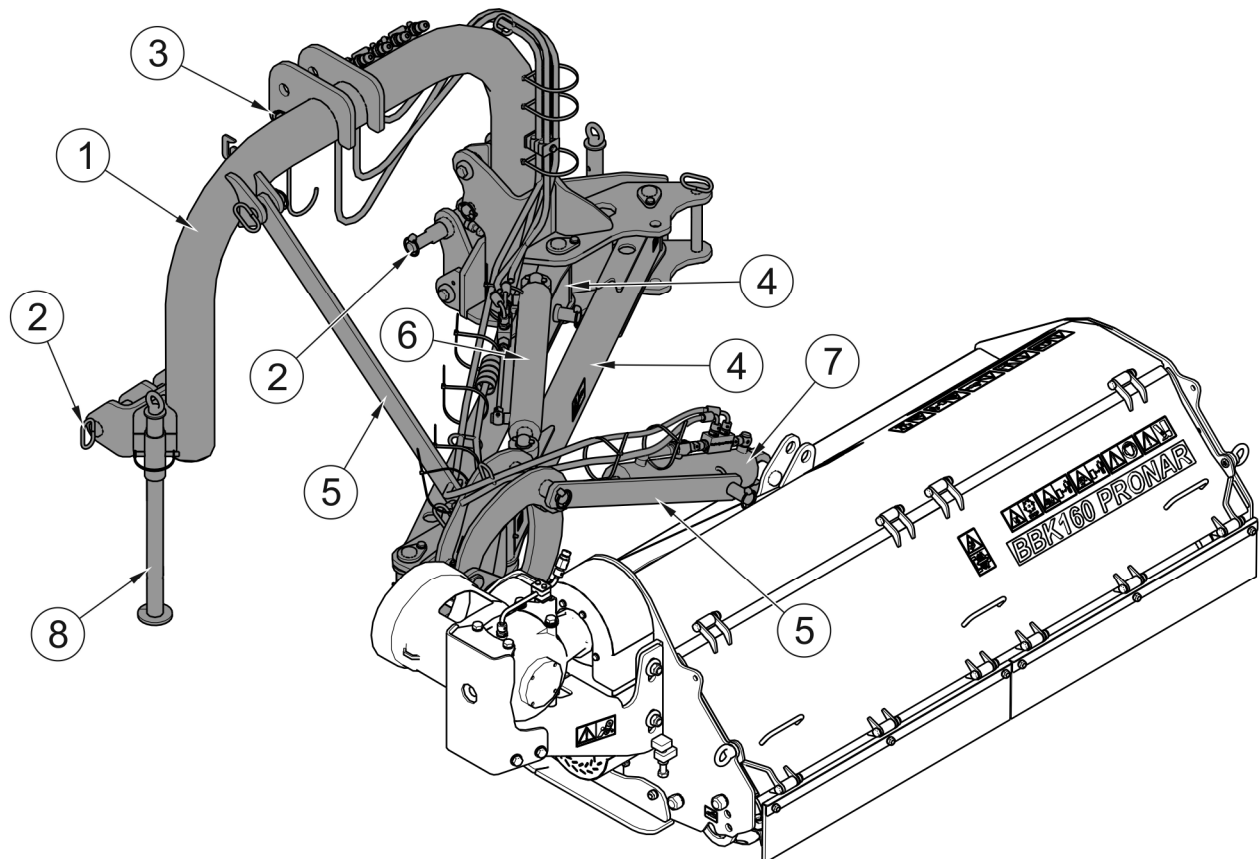
### 3.2 GENERAL DESIGN



**FIG. 3.2** General design

(1)- linkage; (2)- cutting unit housing; (3)- rubber guard; (4)- slide; (5)- PTO shaft; (6)- intersecting axis gear; (7)- belt transmission; (8)- flail shaft; (9)- tracking shaft; (10)- hydraulic system;

### 3.3 LINKAGE



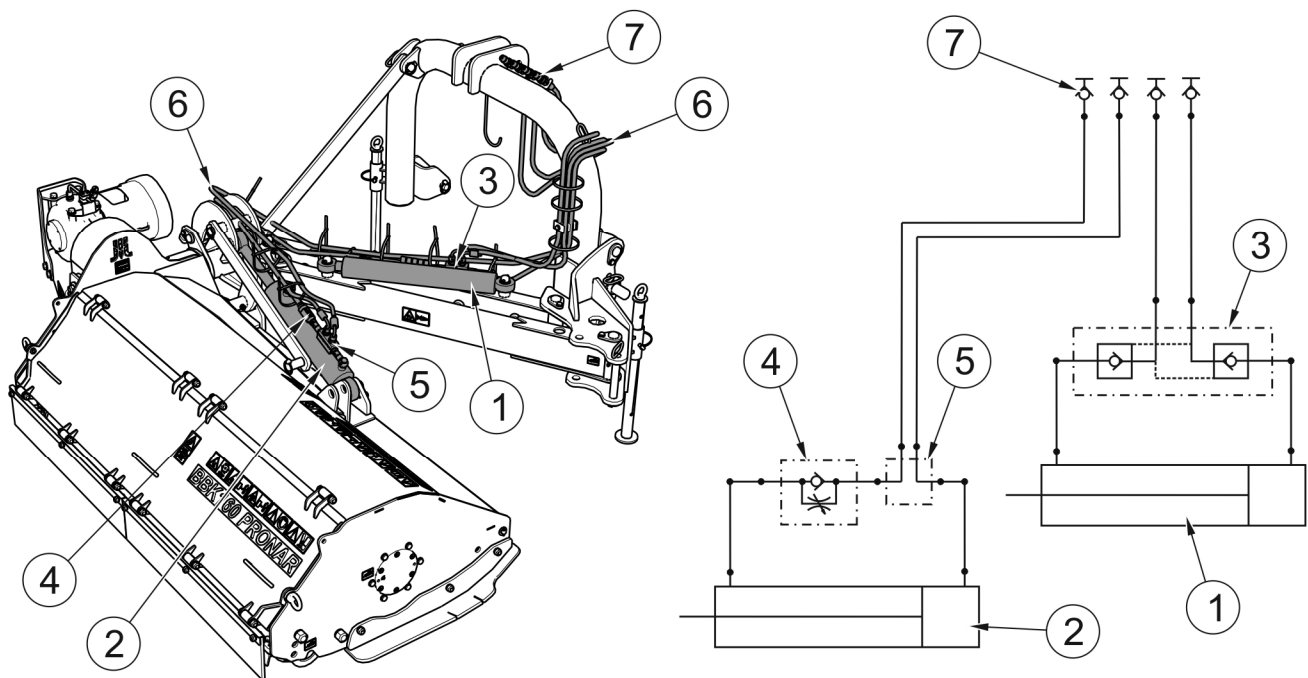
**FIG. 3.3 Linkage**

(1)- three-point linkage frame; (2)- pins of lower links; (3)- central link pin; (4)- movable hitching eyes I and II of mower linkage; (5)- hydraulic cylinder locks; (6)- tipping cylinder; (7)- tilt cylinder; (8)- parking stand

PRONAR BBK160 / BBK180 / BBK200 rear-lateral flail-mowers are hitched to the tractor's rear three-point linkage.

The main element of the mower linkage (FIGURE 3.3) is the three-point linkage frame (1), equipped with two lower pins (2) and upper pin (3) for connection to the tractor's rear three point linkage. Movable hitching eyes I and II (4) connected with hydraulic tipping cylinder (6) enable a wide horizontal range of operation. Tilt cylinder (7) enables mowing on surfaces with the following maximum inclinations:  $+94^{\circ}$  and  $-65^{\circ}$ . Such a design facilitates manoeuvring the mower between trees, road signs or roadside posts and barriers, without changing the tractor's route.

### 3.4 HYDRAULIC SYSTEM



**FIG. 3.4** Hydraulic system design

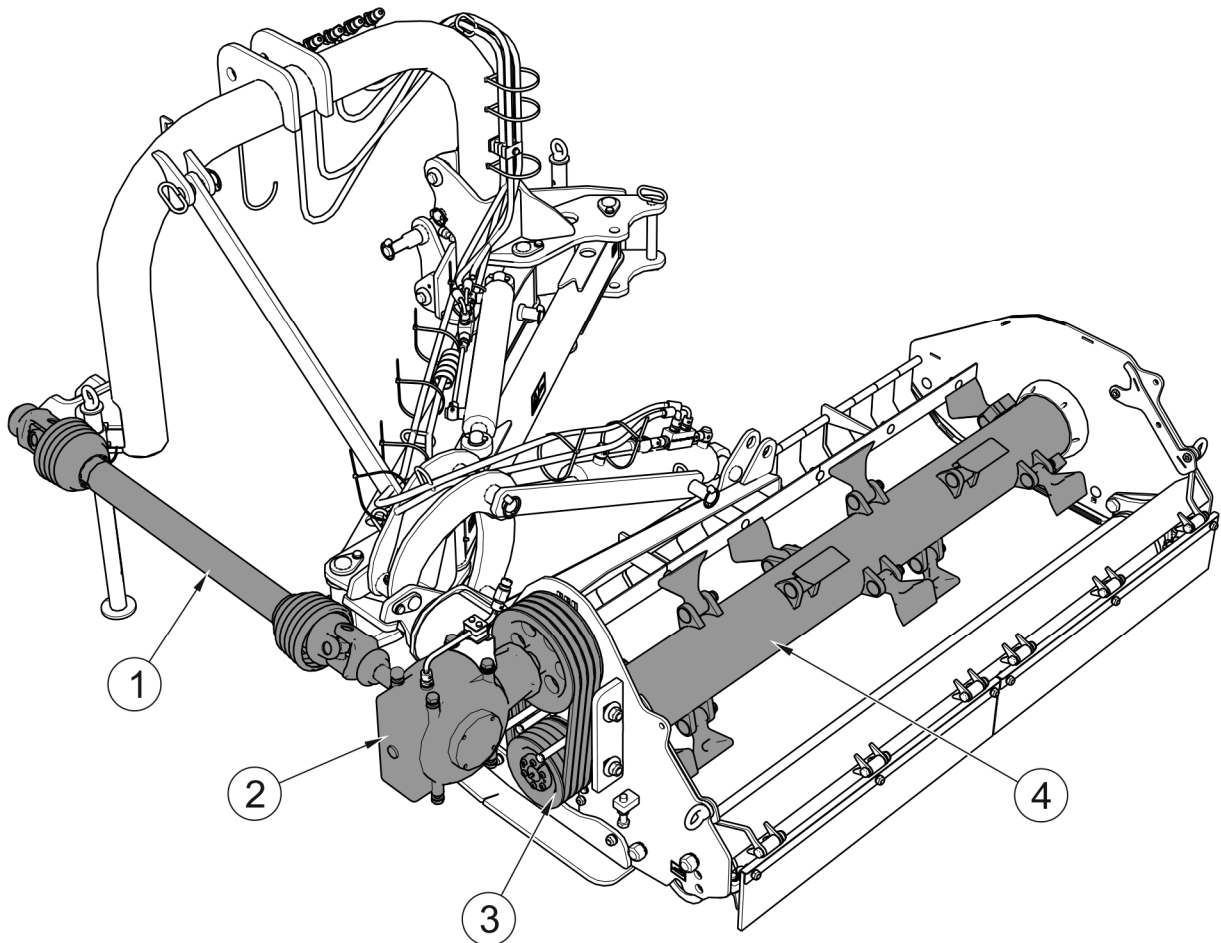
(1)- horizontal tipping hydraulic cylinder; (2)- inclination adjustment hydraulic cylinder; (3)- hydraulic lock; (4)- adjustable throttle valve; (5)- connection block; (6)- hydraulic conduits; (7)- hydraulic quick couplers

The mower's hydraulic system is used for adjusting horizontal tipping and inclination angle. Such a design facilitates manoeuvring the mower when mowing on road shoulders, slopes, embankments, in drainage ditches and water channels, without changing the tractor's route. Thanks to its wide range of shift, the mower can work as a rear or lateral mower.

The mower's hydraulic system consists of double-acting hydraulic cylinders (1, 2) that are supplied from the tractor's external hydraulic system and connected by means of hydraulic conduits (6) through hydraulic quick couplers (7). On the horizontal tipping cylinder (1) there is a hydraulic lock (3) that blocks movement of the hydraulic cylinder in both directions after the mower position is set. Throttle valve (4) on inclination adjustment cylinder (2) enables smooth adjustment of machine position.



## 3.5 DRIVE TRANSMISSION

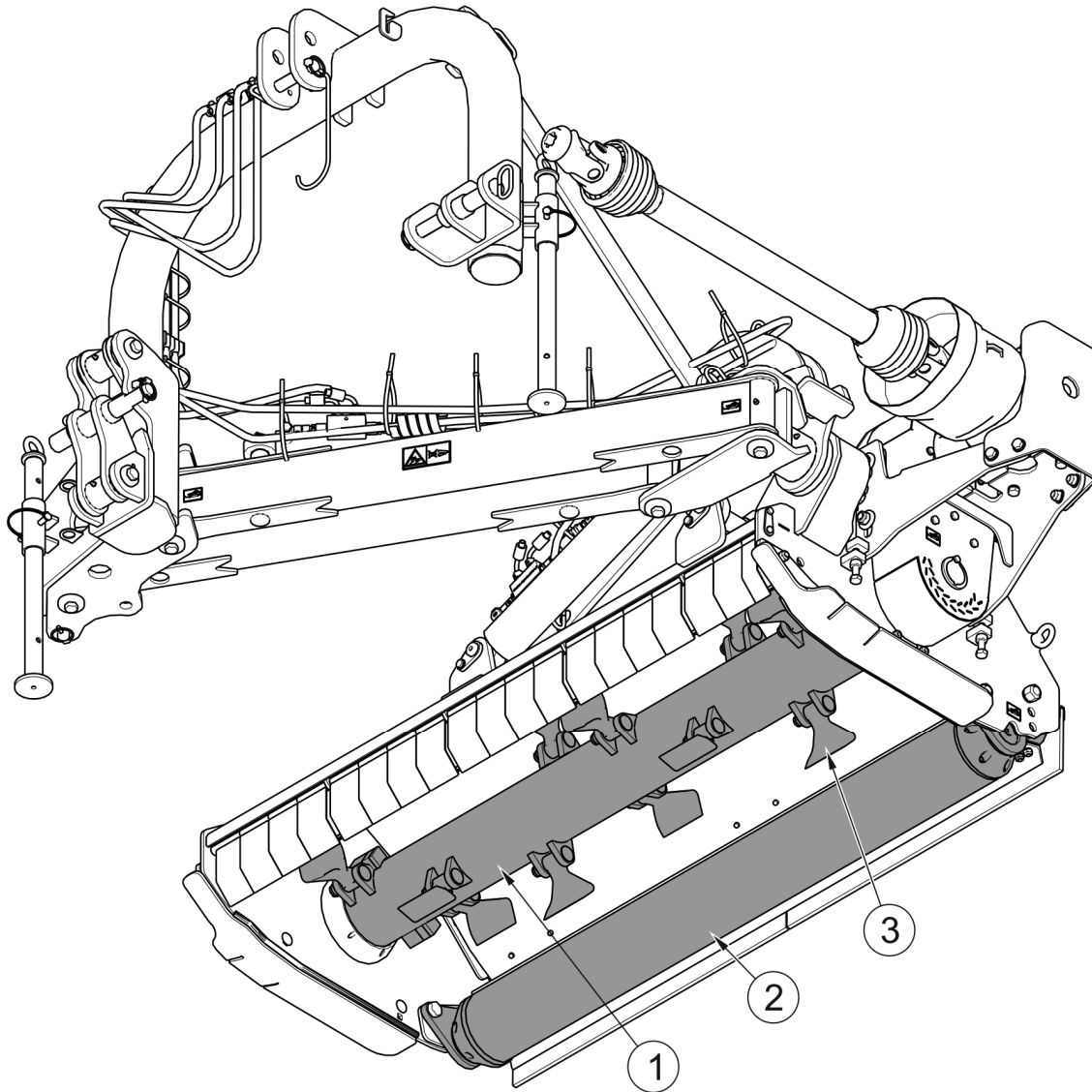


**FIG. 3.5** Drive transmission

(1)- PTO shaft; (2)- intersecting axis gear; (3)- belt transmission; (4)- flail shaft

The torque is transmitted from the tractor's PTO shaft through a wide-angle PTO shaft (1) to intersecting axis gear (2) equipped with a backstop clutch. Next, the torque from intersecting axis gear (2) is transmitted to flail shaft (4) with the use of the belt transmission (3). In this case, the belt transmission performs also the function of overload protection clutch.

## 3.6 CUTTING UNIT



**FIG. 3.6**      **Cutting unit**

(1)- flail shaft; (2)- tracking shaft; (3)- flail blade

The cutting unit of PRONAR BBK160 / BBK180 / BBK200 mowers consists of flail shaft (1) on which flail blades are mounted (3). The flail blades are designed to swing and avoid obstacles which can not be cut. Cutting height is adjusted by changing the tracking shaft (2) setting. Flail shaft is mounted on bearings installed in the cutting unit housing.

*SECTION*

**4**

---

**CORRECT USE**

## 4.1 PREPARING FOR WORK

The manufacturer guarantees that the machine is fully operational and has been checked according to quality control procedures and is ready for use. This does not release the user from an obligation to check the machine's condition after delivery and before first use. The machine is delivered to the user completely assembled.



### ATTENTION!

Before using the mower always check its technical condition. In particular, check the technical condition of cutting unit, drive unit and completeness of safety guards.



### ATTENTION!

Before connecting the mower to tractor adjust the length of PTO shaft according to the PTO shaft Operator's Manual.

Before connecting to tractor, machine operator must check the technical condition of the mower and prepare it for test start-up. In order to do this:

- the user must carefully read this Operator's Manual and observe all recommendations, understand the design and the principle of machine operation
- check the condition of protective paint coat,
- Inspect machine's individual components for mechanical damage resulting from incorrect transport (dents, piercing, bent or broken components),
- Check all the lubrication points, lubricate the machine according to recommendations provided in *section 5 "MAINTENANCE"*,



### ATTENTION!

Before beginning work lubricate flail shaft bearings and tracking shaft bearings until grease appears between the shaft and bearing housing.

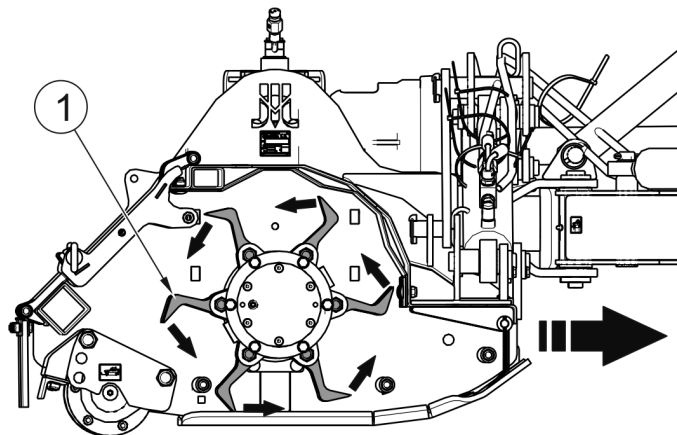
- check technical condition of the hydraulic system,
- check if flail blades, cutting shaft, linkage and safety guards are correctly installed.
- check technical condition of hitching system pins and locking cotter pins,
- check lubricating oil level in intersecting axis gear.

If all the above checks have been performed and there is no doubt as to the machine's good technical condition, it can be connected to tractor. Start the tractor's engine, check all systems and perform a test run before beginning work. In order to inspect:

- hitch the mower to tractor (see "*HITCHING TO TRACTOR*")
- remove hydraulic cylinder locks and place them on special pins and secure with linchpins (FIGURE 4.5),
- set in working position,
- adjust the length of PTO shaft to compatible tractor according to the Operator's Manual of PTO shaft,
- connect PTO shaft to tractor and mower,
- start PTO drive.

Engage mower's drive for 3 minutes and check the following:

- that there is no knocking or noise in the drive system arising from scraping or grinding of metal elements,
- whether there is excessive vibration in the cutting unit,
- synchronised rotation of cutting unit (FIGURE 4.1).



**FIG. 4.1**      **Rotation of cutting unit synchronised with direction of tractor travel.**

(1)- cutting unit

**ATTENTION!**

Before using the mower always check its technical condition. In particular check the technical condition of the cutting unit, linkage, drive system, and integrity of protective guards.

The mower's operation at no load should be smooth. Shaking of drive transmission, cutting unit and whole machine is not acceptable, nor is changed noise and vibrations coming from loose nut and bolt connections. After stopping mower, check fastening of flail blades. Check that oil does not leak from the intersecting axis gear.

**DANGER**

Before using the mower, the user must carefully read this operator's manual.

Careless and improper use and operation of the mower, and non-compliance with the recommendations given in this operator's manual is dangerous to your health.

The mower must never be used by persons, who are not authorised to drive agricultural tractors, including children and people under the influence of alcohol or other drugs.

Non-compliance with the safety rules of this Operator's Manual can be dangerous to the health and life of the operator and others.

Before starting the mower, make sure that there are no bystanders in the danger zone.

If any faults are detected they must be identified and rectified. If a fault cannot be rectified or the repair could void the warranty, please contact retailer for additional clarifications.

## 4.2 CHECKING TECHNICAL CONDITION

When preparing the mower for normal use, check individual elements according to guidelines presented in table (4.1).

**TAB. 4.1 TECHNICAL INSPECTION SCHEDULE**

DESCRIPTION	SERVICE OPERATION	FREQUENCY
Condition of safety guards	Check technical condition of safety guards, if complete and correctly mounted.	Daily before beginning work
Check if the shaft and linkage are correctly installed	check if correctly installed	
Technical condition of flail blades	Visually inspect and if necessary replace according to section „ <i>CHECKING AND REPLACING CUTTING KNIVES</i> ”	
Oil level in intersecting axis gear	For details please refer to section “ <i>DRIVE SYSTEM OPERATION</i> ”	
Tightening of all main nut and bolt connections	Tightening torque values should be according to table „ <i>TIGHTENING TORQUE FOR NUT AND BOLT CONNECTIONS</i> ”	Every six months
Lubrication	Lubricate elements according to table <i>LUBRICATION</i> .	According to table (5.2)




### ATTENTION!

Do NOT use unreliable mower.

## 4.3 HITCHING TO TRACTOR


### 4.3.1 HITCHING TO THE TRACTOR REAR THREE-POINT LINKAGE

The PRONAR BBK160 / BBK180 / BBK200 mower may only be mounted on a tractor fulfilling the requirements contained in table „1.1 AGRICULTURAL TRACTOR'S REQUIREMENTS”.



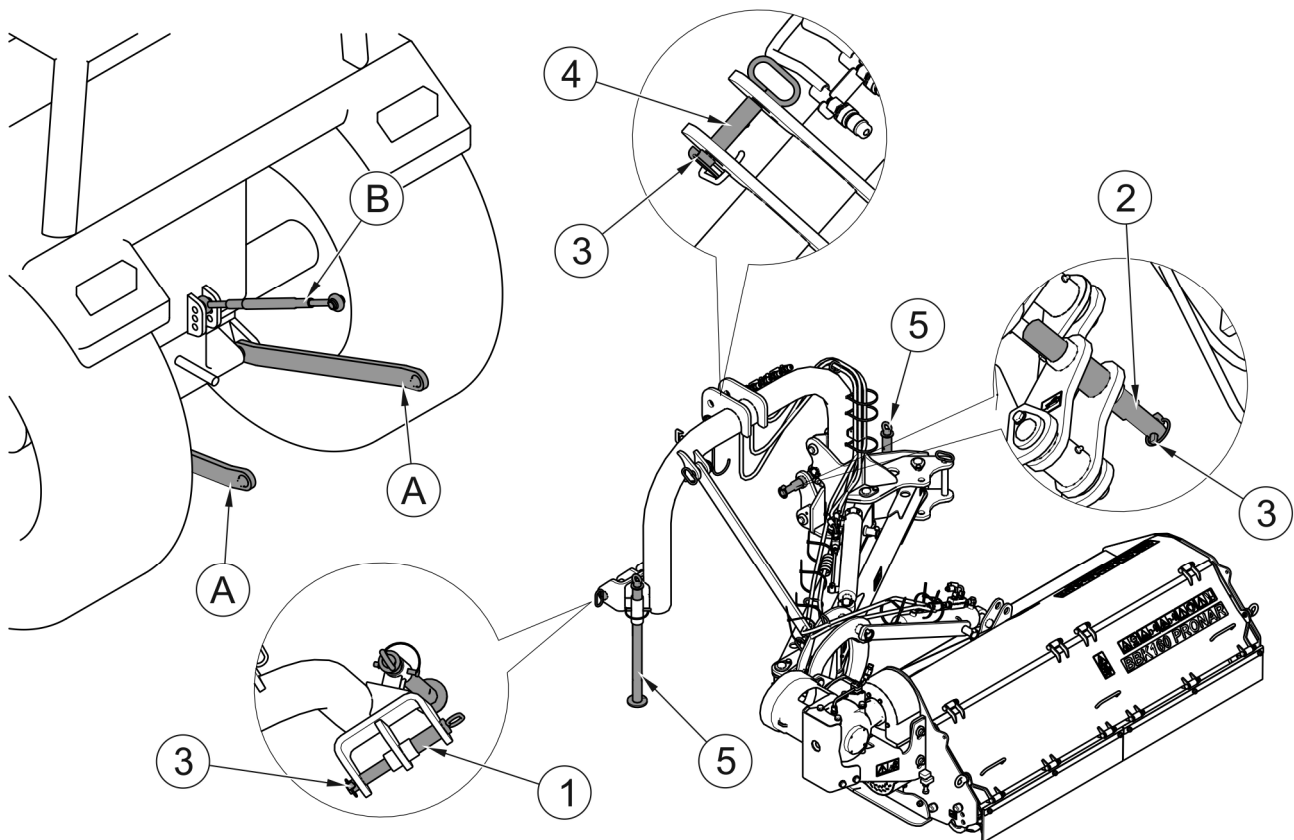
**ATTENTION!**

Before using the mower, the user must carefully read the tractor operator's manual.



**DANGER**

When hitching, there must be nobody between the machine and the tractor. Exercise caution when hitching the machine.



**FIG. 4.2** Hitching to tractor

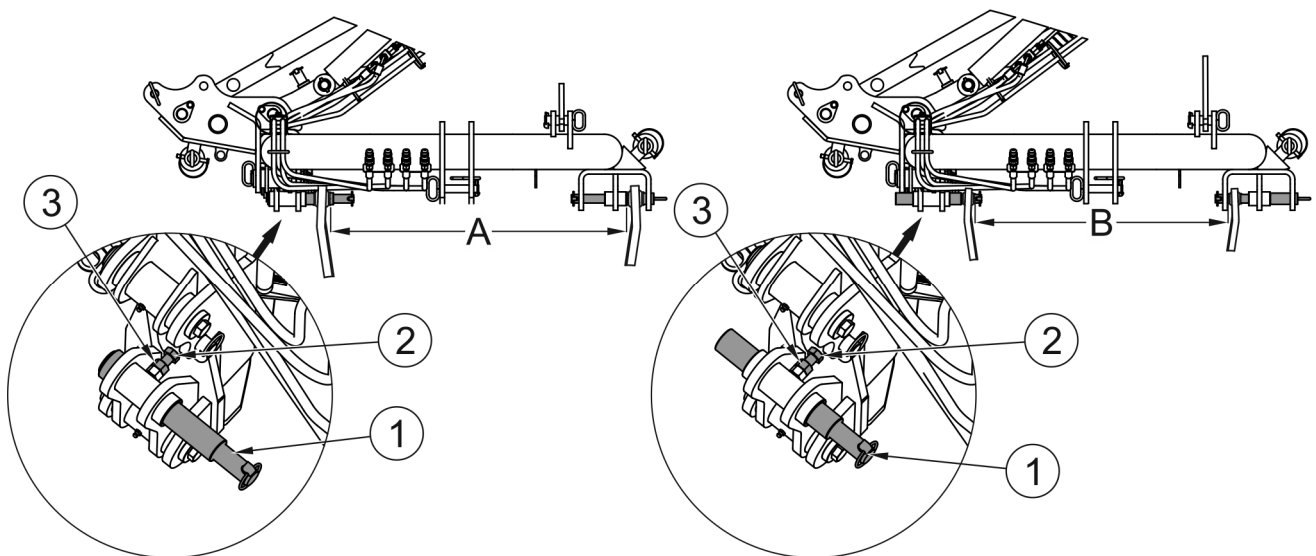
(A)- lower links of the tractor's three point linkage; (B)- top link; (1)- lower linkage pin – category II-III; (2)- lower linkage pin – category II; (3)- cotter pin; (4)- top link mounting pin; (5)- parking stand



In order to attach the mower to tractor rear three-point linkage (FIG. 4.2), proceed as follows:

- reversing the tractor bring the lower three point linkage connection points (A) of the tractor close to pins (1) of the mower,
- set links (A) of tractor at appropriate height,
- switch off tractor's engine and prevent it from moving,
- connect lower pins (1) with linkage arms (A) and lock with the aid of cotter pins,
- connect top link (B) of tractor with pin (4) mower and lock with cotter pin (3),
- lift mower using tractor's three point linkage,
- raise parking stand (5) and secure with a cotter pin.

Both lower links of the tractor's three point linkage are recommended to be set at the same height .



**FIG. 4.3 Adjustment of lower pins of the mower's linkage**

(A)- spacing of pins for cat. III three-point linkage; (B)- spacing of pins for cat. II three-point linkage; (1)- lower pin of the mower linkage; (2)- retaining bolt; (3)- counter nut

Lower pin (1) of the mower linkage enables adjustment of spacing (FIGURE 4.3). To change spacing of linkage pins:

- loosen counter nut (3),
- unscrew retaining bolt (2),
- move pin (1) to the right or the left to obtain the required spacing,

- block pin position with retaining bolt (2) and counter nut (3).

As standard the mower is equipped with pins for linking with category II and III linkage according to ISO 730-1.

**ATTENTION!**

Comply with the recommendations relating to linkage and mounting points.

**DANGER**

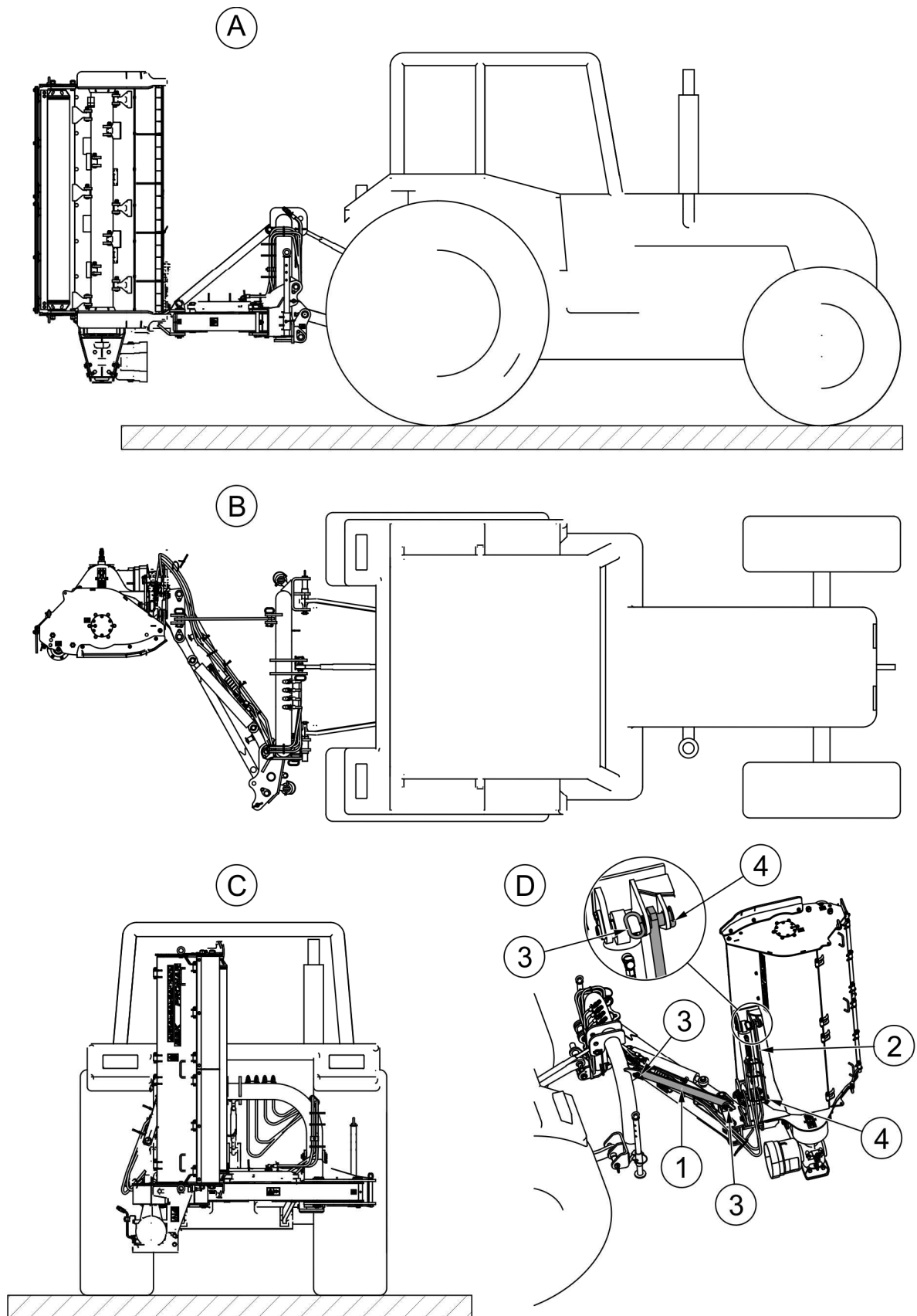
Prior to connecting hydraulic system lines the user must carefully read the tractor operator's manual and observe all recommendations of the Manufacturer.

**DANGER**

When connecting the hydraulic lines to the tractor, make sure that the tractor hydraulic system is not under pressure.

## 4.4 TRANSPORTING THE MACHINE

For transport to place of work and back, raise mower on tractor three point linkage so that the lower pins are at height of not less than 500 mm above the ground. Set the minimum lateral tipping of the mower by means of the horizontal tipping cylinder (the cylinder piston should be maximally retracted). Raise the mower to vertical position by means of the inclination adjustment cylinder and secure the cylinders using cylinder locks (1, 2), pins (3) and linchpins (4) (FIGURE 4.4). Disconnect PTO shaft from tractor's PTO and place on support. Lower links of the tractor's three point linkage must be secured so that mower does not swing sideways.



**FIG. 4.4** Transport position

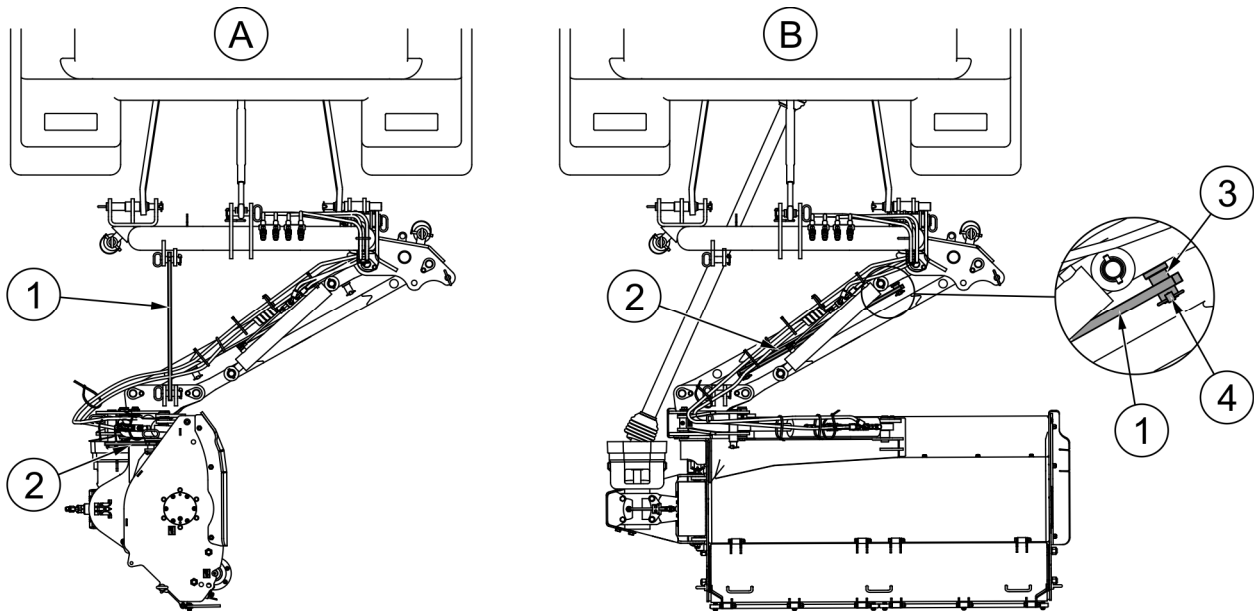
(A)- right side view; (B)- overview; (C)- rear view; (D)- locking of cylinders; (1)- lock I; (2)- lock II; (3)- lock pin; (4)- linchpin

## 4.5 SETTING AND MOWING

### 4.5.1 SETTING THE MOWER IN WORKING POSITION

To set the mower in working position:

- raise the mower on the tractor three point linkage so that the mower does not touch the ground
- disconnect hydraulic cylinder locks (1, 2), attach them to link pins (3) and secure with linchpins (4) (FIGURE 4.5),
- controlling appropriate hydraulic circuits in the tractor, slide the piston of the cutting unit tipping cylinder to appropriate length,

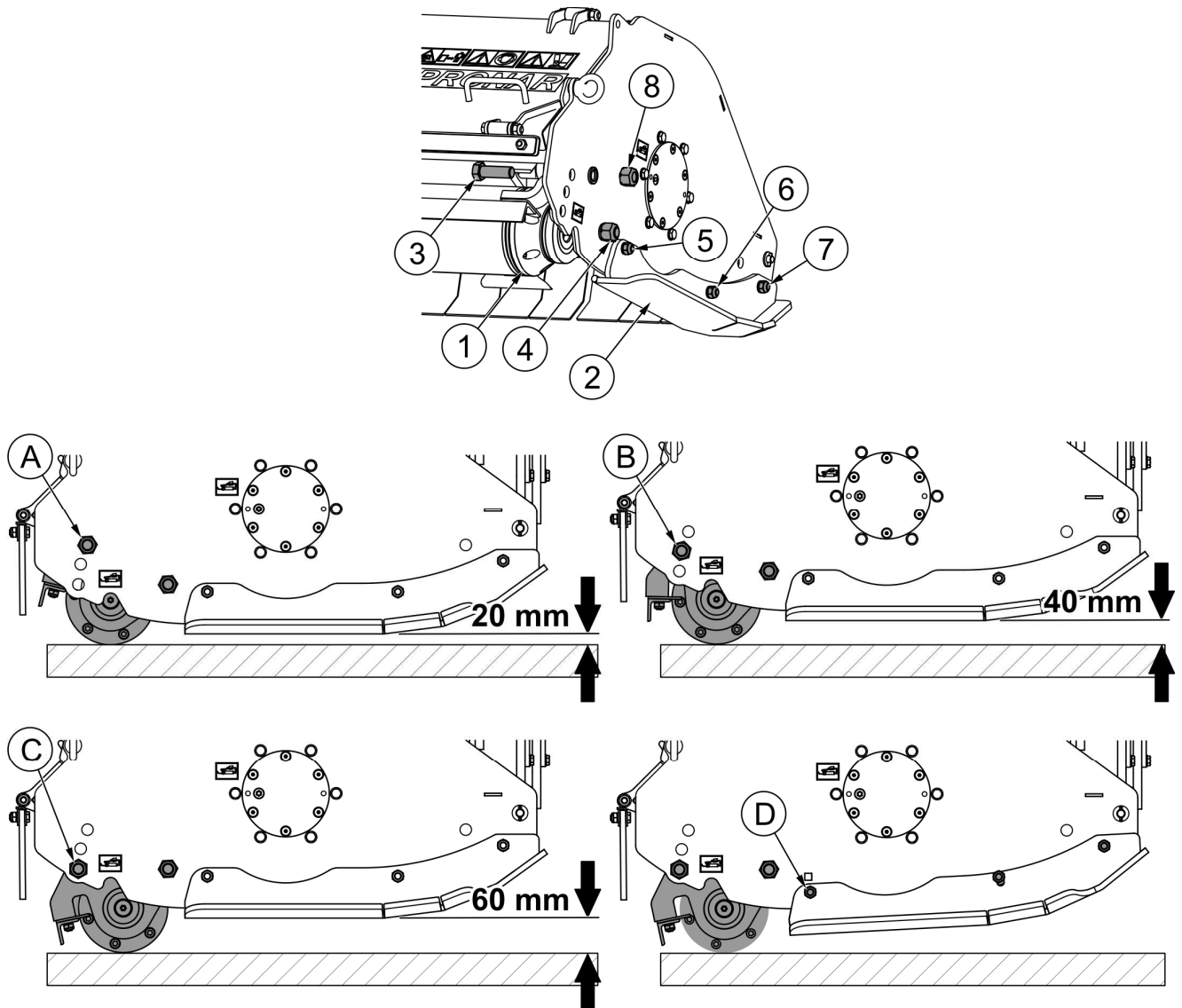


**FIG. 4.5** Setting mower in working position

(A)- transport position; (B)- working position; (1)- cylinder lock I; (2)- cylinder lock II; (3)- link pin; (4)- linchpin

- lower the mower so that the cutting unit is supported freely on the ground, on the tracking shaft. Slides should not touch the ground and the complete cutting unit should be set in parallel to the ground (FIGURE 4.6).

### 4.5.2 SETTING CUTTING HEIGHT



**FIG. 4.6** Setting mower cutting height.

(1)- tracking shaft; (2)- slide; (3)- tracking shaft fixing bolt; (4)- nut; (5)- slide fixing bolt; (6)- nut; (7)- nut; (8)- nut; (A)- position of the bolt setting cutting height of 20 mm; (B)- position of the bolt setting cutting height of 40 mm; (C)- position of the bolt setting cutting height of 60 mm; (D)- position of the bolt setting slide angle

Adjust the length of the top link of the three point linkage in such a way as to ensure that the mower slides are set in parallel to the ground. Cutting height can be modified by changing the tracking shaft (1) position with regard to the mower housing. In order to do this (FIGURE 4.6):

- loosen nuts (4) of bolts on both sides of the tracking shaft (1) on which the tracking shaft will be turned;
- undo nuts (8) and remove fixing bolts (3) on both sides of the tracking shaft,

- turn the tracking shaft with bracket so as to ensure that the opening in the bracket aligns with the opening in the side of the mower housing, depending on the cutting height to be achieved: A (20 mm), B (40 mm) or C (60 mm),
- insert fixing bolts (3) into appropriate openings and screw on the nuts (8),
- tighten nuts (4) of the bolt on which the tracking shaft was turned, on both sides of the tracking shaft.

When changing cutting height to 40 mm or 60 mm, it is recommended to change slides (2) angle simultaneously. Consequently, the tracking shaft rake angle at the moment of collision with obstacle will be reduced. In order to do this:

- loosen nuts (6) and (7) of the bolts securing the slide,
- unscrew nut and take out bolt (5) fixing the slide,
- turn the slide so as to ensure that the slide opening aligns with the lower opening in the side of the mower housing (D) (FIGURE 4.6),
- insert fixing bolt (5) into the aligned openings and screw on the nut,
- tighten nuts (6) and (7) of the bolts securing the slide,
- Angle of the slide located on the opposite side of the mower housing should be also changed.

### 4.5.3 CONNECTING DRIVE SHAFT



#### **DANGER**

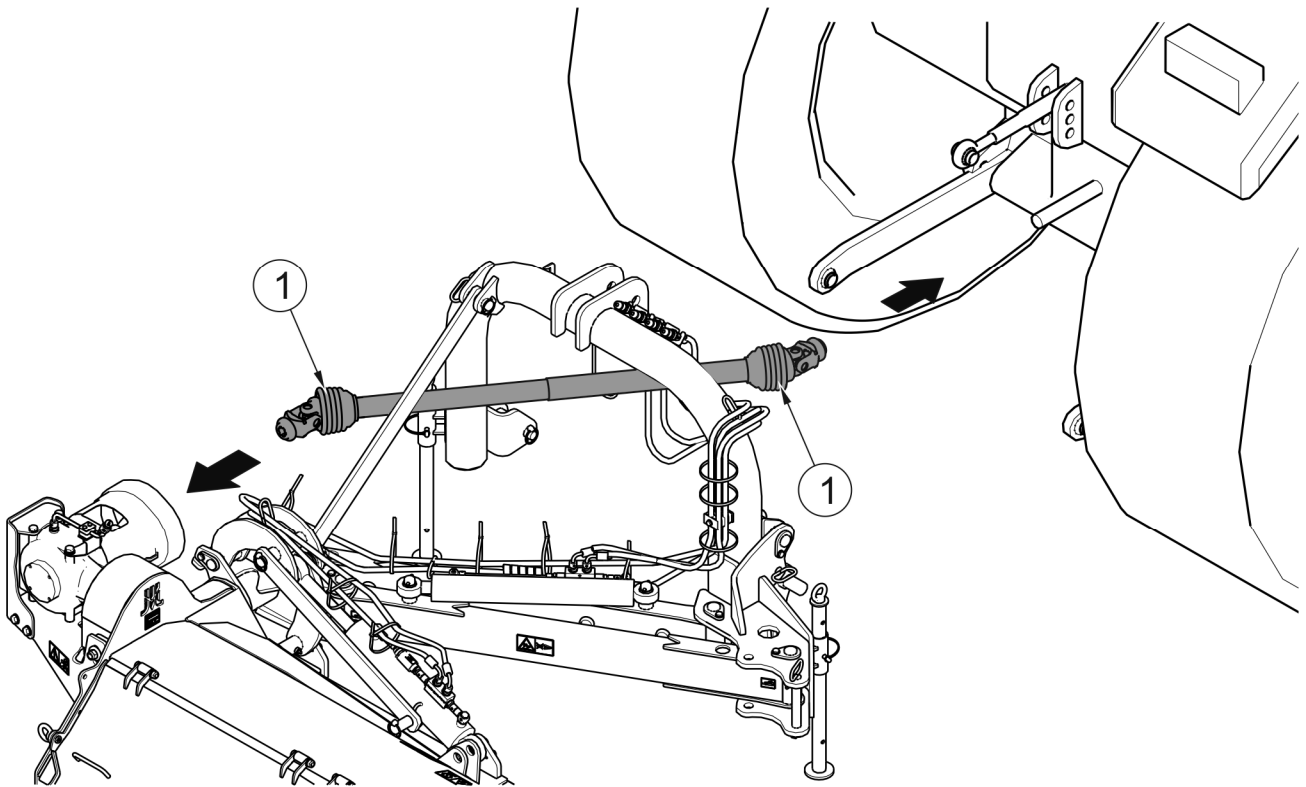
**Before connecting the shaft, turn off the tractor's engine and remove the key from the ignition. Ensure that unauthorised persons do not have access to the tractor.**

**The use of PTO shaft and its technical condition must be in accord with the Operator's Manual of PTO shaft.**

Before connecting the mower it is absolutely necessary to carefully read the Operator's Manual attached by the Manufacturer of the shaft and observe the instructions contained in it. Before connection to the tractor check the technical condition of the shaft guards (1) (FIGURE 4.7), the completeness and condition of the protecting chains and the general technical condition of the shaft.

**ATTENTION!**

Before connecting the mower to tractor adjust the length of PTO shaft according to the PTO shaft Operator's Manual.



**FIG. 4.7**      **Connecting PTO drive shaft**

*(1)- PTO shaft shields*

#### 4.5.4 MOWING

##### **DANGER**



The mower may only be started when all guards are in place and the cutting unit is set in working position.

Before engaging drive to PTO shaft make sure that there are no bystanders, especially children, near the mower.

Other persons should be at a safe distance from the mower during work because of the danger that objects may be thrown (stones, branches from beneath rotating disks).

##### **ATTENTION!**



Before beginning work lubricate flail shaft bearings and tracking shaft bearings until grease appears between the shaft and bearing housing.

After setting the mower in working position and adjusting cutting height, the machine starting procedure may begin. Engage the PTO in the tractor at a suitably low speed and then gradually increase the speed until PTO speed of 540 rpm is reached.

##### **ATTENTION!**



During mowing, the lever controlling the inclination adjustment cylinder should be set in "floating" position, whereas the lever controlling the tipping cylinder should be set in neutral position.

When mowing and chopping pay attention to uneven surface and obstacles in the mown crop. Mowing speed depends on the quantity and quality of mown crop but also on the type of terrain.

Mowing speed must be reduced if:

- mown ground is uneven,
- mown and chopped crop is very high and dense,
- there is a great risk of running into foreign bodies e.g. stones, thick branches, steel or concrete objects.

When driving across the road, pavement or other obstacles and when making turns, raise the mower by means of the tractor three-point linkage and disengage the drive.



Be especially careful when mowing along ditches, furrows and slopes. If the drive belts slip in the belt transmission during mowing, disengage the drive and check the cause of the overload. Belt slipping may occur because of too low rotation speed of the cutting unit.



### **HIGH NOISE LEVEL WARNING**

Depending on the working conditions, the tractor with the machine may generate noise exceeding the level of 85dB at the driver position. In such conditions the driver should apply individual protection (protective ear guards).

In order to reduce the level of noise during work the tractor cab window and door should be closed.

## **4.5.5 REMOVING BLOCKAGES**



### **DANGER**

If the mower drive transmission system or cutting unit is blocked, switch off tractor engine and remove key from ignition. Secure tractor using parking brake and ensure that unauthorised persons, especially children, have no access to the tractor.

In the event of work requiring the mower to be raised, after lifting the machine, stable and durable supports must also be used. Do NOT carry out work under a machine, which has only been raised with the three point linkage.

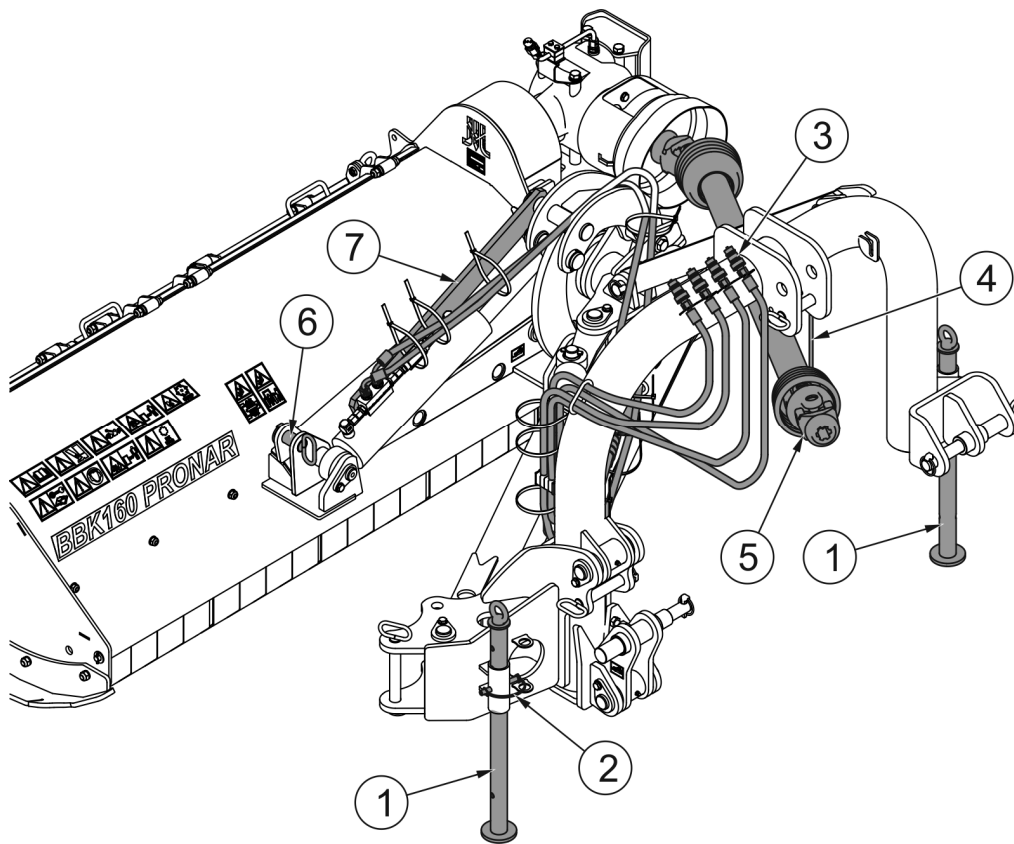
The machine must not be supported using fragile elements (bricks or concrete blocks).

If the belts slip in the belt transmission during mowing, disengage the drive and check the cause of blockage. If blockage occurs as a result of accumulation of mown crop or wrapping of mown crop around the mower's cutting unit or as a result of contact with foreign objects (stones, branches, heaps of soil), remove accumulated crop (using a sharp tool) and check condition of cutting elements and their mounting.

In order to reduce the risk of blockage of cutting elements to minimum, mowing speed must be reduced if:

- mown ground is uneven,
- mown and chopped crop is very high and dense,
- there is a great risk of running into foreign bodies e.g. stones, thick branches, steel or concrete objects.

## 4.6 DISCONNECTING FROM TRACTOR



**FIG. 4.8**      **Disconnecting mower from tractor**

(1)- parking stand; (2)- securing linchpin; (3)- hydraulic conduit connectors; (4)- PTO shaft support; (5)- PTO shaft; (6)- pin; (7)- cylinder lock



### **DANGER**

**Reduce pressure prior to disconnecting the hydraulic system.**

In order to disconnect the mower from the tractor (FIG. 4.8) proceed as follows:

- lower mower using three-point linkage to rest position,
- take out pin (6), release cylinder lock (7), set the mower to horizontal position and set it on the ground,
- switch off tractor engine and remove key from ignition,
- take out securing linchpin (2), lower parking stand (1) and lock it again with securing linchpin (2),

- reduce residual pressure in the hydraulic system by movement of appropriate lever controlling hydraulic circuit,
- disconnect hydraulic conduit connectors (3) from tractor and place in special brackets on mower frame,
- disconnect PTO shaft (5) from tractor PTO drive and place on support (4),
- disconnect top link of three-point linkage,
- disconnect lower pins and drive tractor away.

After disconnecting from tractor, mower should be supported on parking stand (1) (FIGURE 4.8) and on tracking shaft.



***SECTION***


**5**

---

**MAINTENANCE**

## 5.1 INSPECTION AND DISASSEMBLY OF SAFETY GUARDS

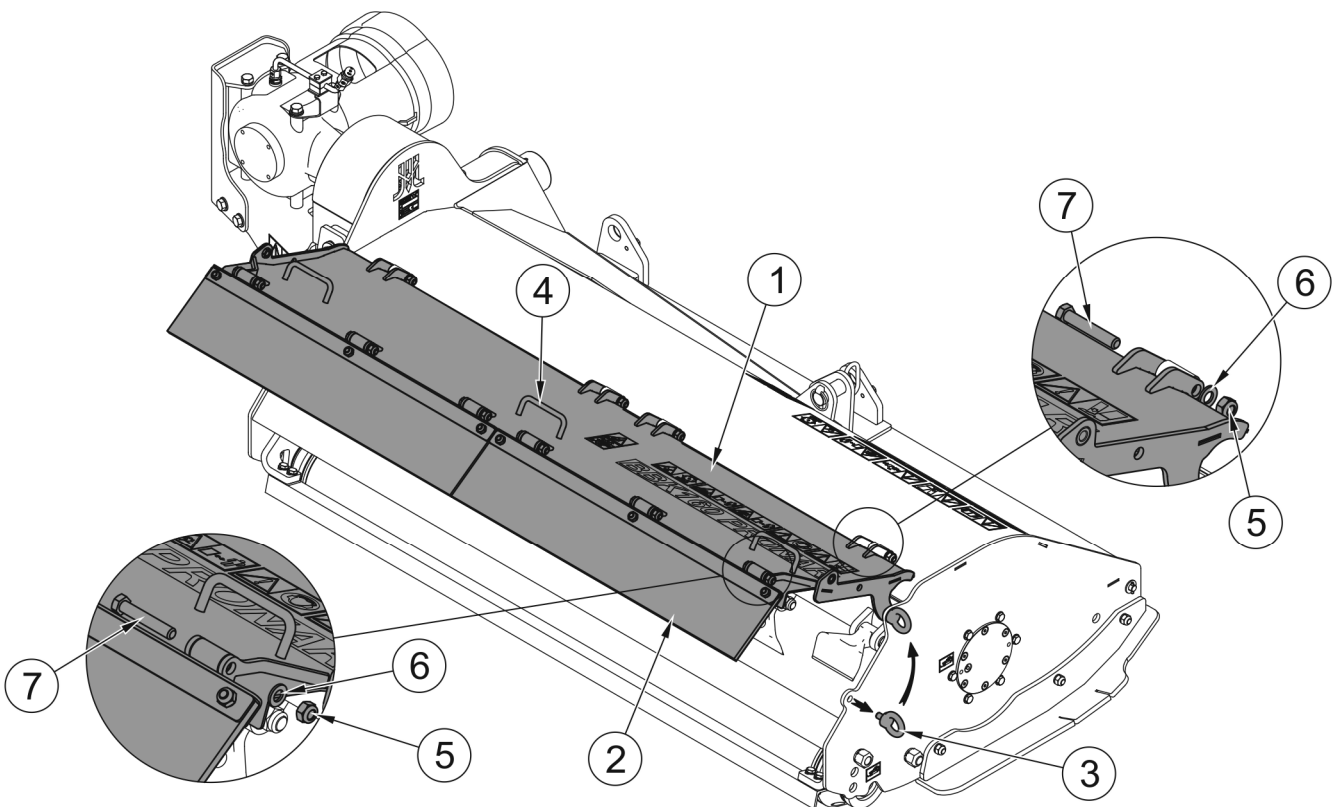
The machine may only be used when all the safety guards and other protective elements are technically sound and correctly positioned. Safety guards should protect against stones and other foreign objects thrown from the mower. In the event of loss or destruction of the safety guards, they must be replaced with new ones.



**DANGER**

During inspection and dismantling of guards, switch off tractor engine and remove the key from the ignition and disengage PTO shaft. Mower must rest on the ground. Ensure unauthorised persons, especially children, have no access to the machine.

PRONAR BBK160 / BBK180 / BBK200 rear-lateral flail-mowers are equipped with a liftable shield that enables efficient removal of collected mown material.



**FIG. 5.1** Opening and removal of liftable shield

(1)- liftable shield; (2)- rubber shield; (3)- eye bolt; (4)- handle; (5)- nut; (6)- washer; (7)- bolt

Mowing with the liftable shield open is allowed in places located at a safe distance from buildings (e.g. in corn fields, meadows) in order to ensure more uniform spreading of mown material and more efficient mowing.

To open the liftable shield:

- unscrew eye bolts (3) on both sides of the cutting unit (3),
- raise the shield using handles (4),
- tighten eye bolts (3) as shown in FIGURE 5.1.

When disassembling liftable shield (1) together with complete rubber shields (2), unscrew eye bolts (3), undo nuts (5) and pull out bolts (7). Next, the shields can be removed.



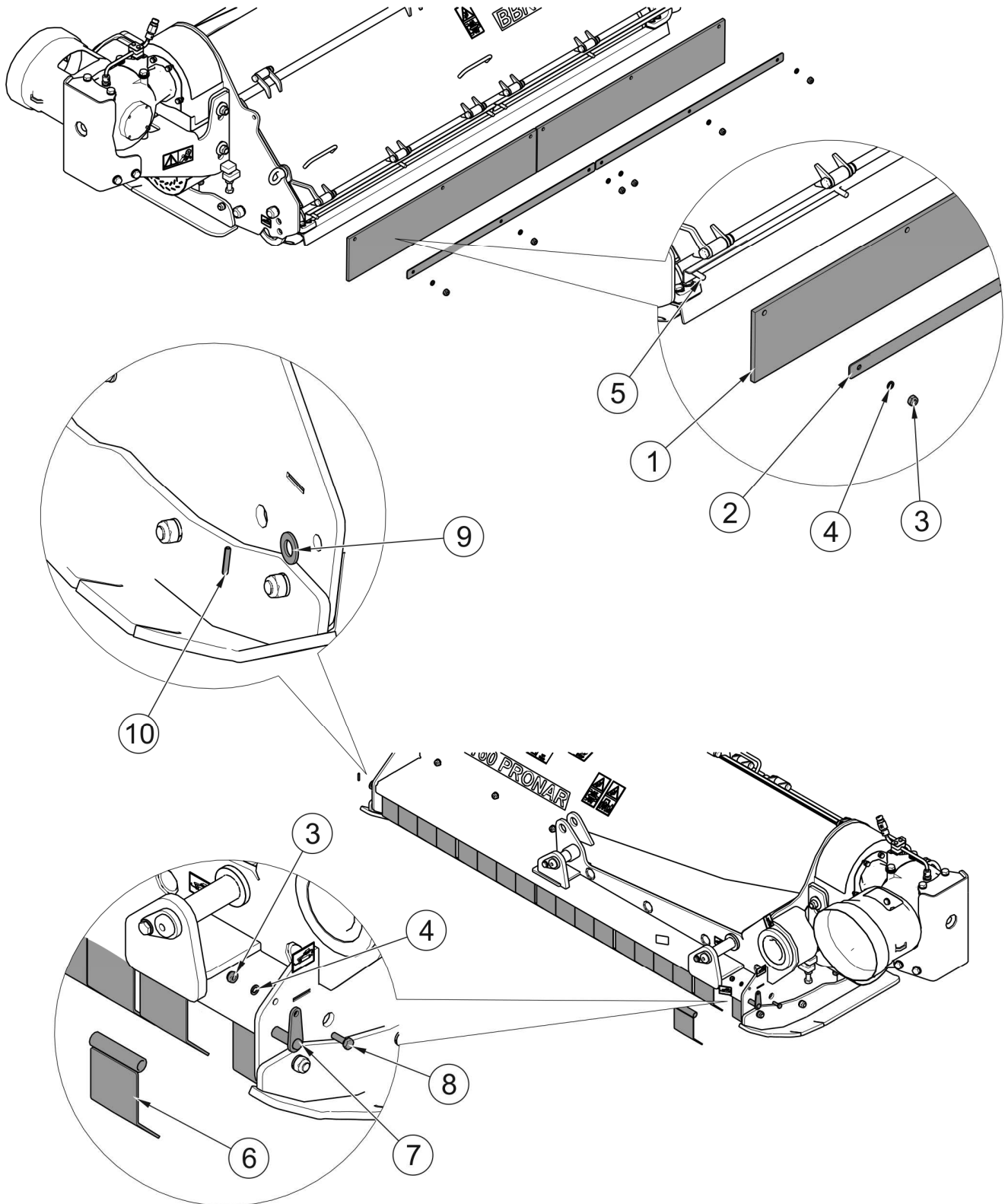
### **IMPORTANT!**

**The mower must not be started if safety guards are damaged, incorrectly mounted or unsecured.**

When disassembling rubber shields (1) (FIGURE 5.2), undo nuts (3) that fix clamping strips (2) and then remove clamping strips (2) and rubber shields (1) from fixing bolts (5).

When disassembling front shield (6), pull out spring pin (10) and remove washer (9). Next, undo nut (3) and pull out bolt (8) that fixes rod (7) on which front shield (6) elements are suspended. After performing these actions, slide out rod (7) so as to enable disassembly and replacement of a damaged element.

Pay special attention to correct mounting of safety guards. Bolts should be tightened using appropriate tightening torque according to table „5.3. *TIGHTENING TORQUE FOR NUT AND BOLT CONNECTIONS*



**FIG. 5.2 Disassembling shields**

(1)- rubber shield; (2)- clamping strip; (3)- nut; (4)- washer; (5)- shield retaining bolt; (6)- front shield; (7)- front shield fixing rod; (8)- bolt; (9)- washer; (10)- spring pin



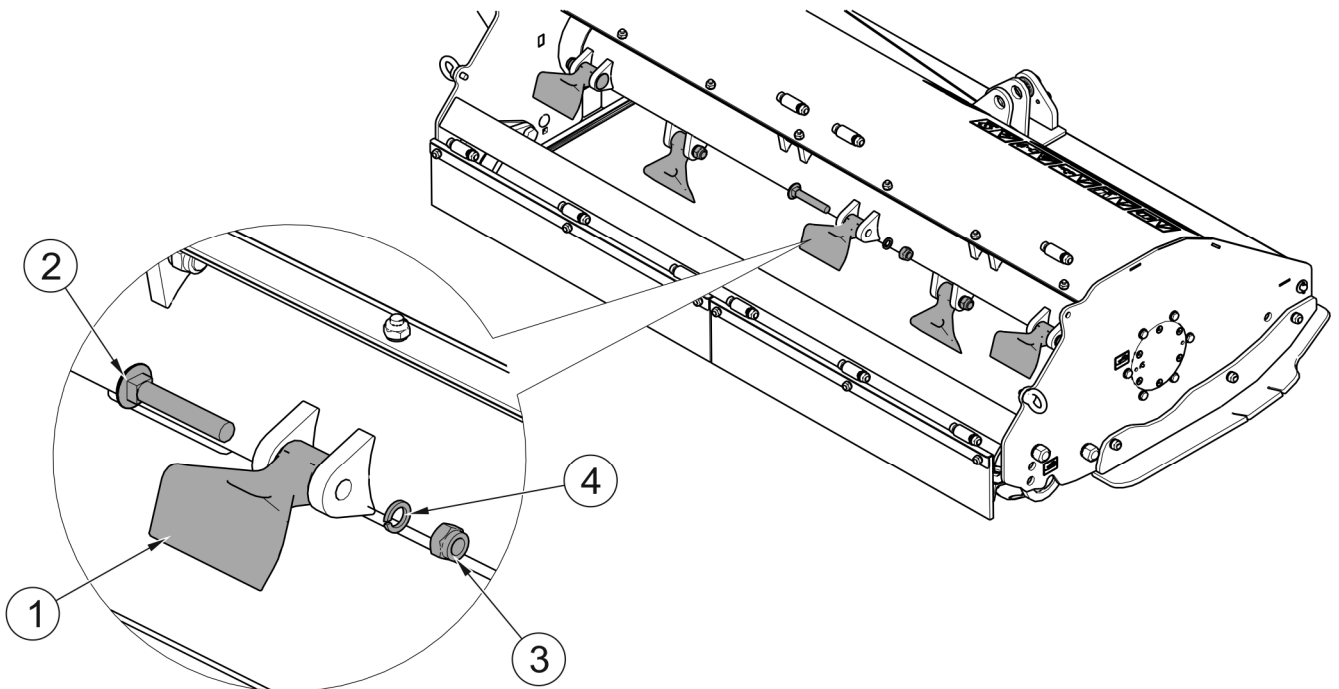
## 5.2 CHECKING AND REPLACING FLAIL BLADES



### DANGER

During inspection and replacement of flail blades, switch off tractor engine and remove the key from the ignition and disengage PTO shaft. Mower must rest on the ground.

Inspections of flail blades must be carried out regularly. Visual inspection involves checking the blade condition and its mounting. Blades should be worn down uniformly and have the same weight and be of the same type. A bent or damaged blade must be replaced with a new one provided by the mower manufacturer. Flail blades must be replaced in pairs (simultaneously with a blade located on the opposite side of the shaft axis) in order to maintain the balance of the flail shaft. Before proceeding to replace the blades, clean the residue of mown material from the flail shaft.



**FIG. 5.3 Replacement of flail blades**

(1)- flail blade; (2)- blade fixing bolt; (3)- nut; (4)- spring washer

When replacing blades (1) pay attention to the condition of bolts (2) securing blade to the flail shaft. Excessively worn or damaged bolt must be replaced with a new one of the same strength class (class 10.9). Bolt nut (3) should be tightened so that flail blades can move freely in the lugs of the flail shaft.

**TIP**

Damaged or worn blades must be changed in pairs (simultaneously with a blade located on the opposite side of the shaft axis) in order to maintain the balance of the flail shaft.

**ATTENTION!**

Missing blade or its fragment will cause imbalance and excessive flail shaft vibration and may damage the mower.

**DANGER**

Use only the blades provided by the mower Manufacturer.

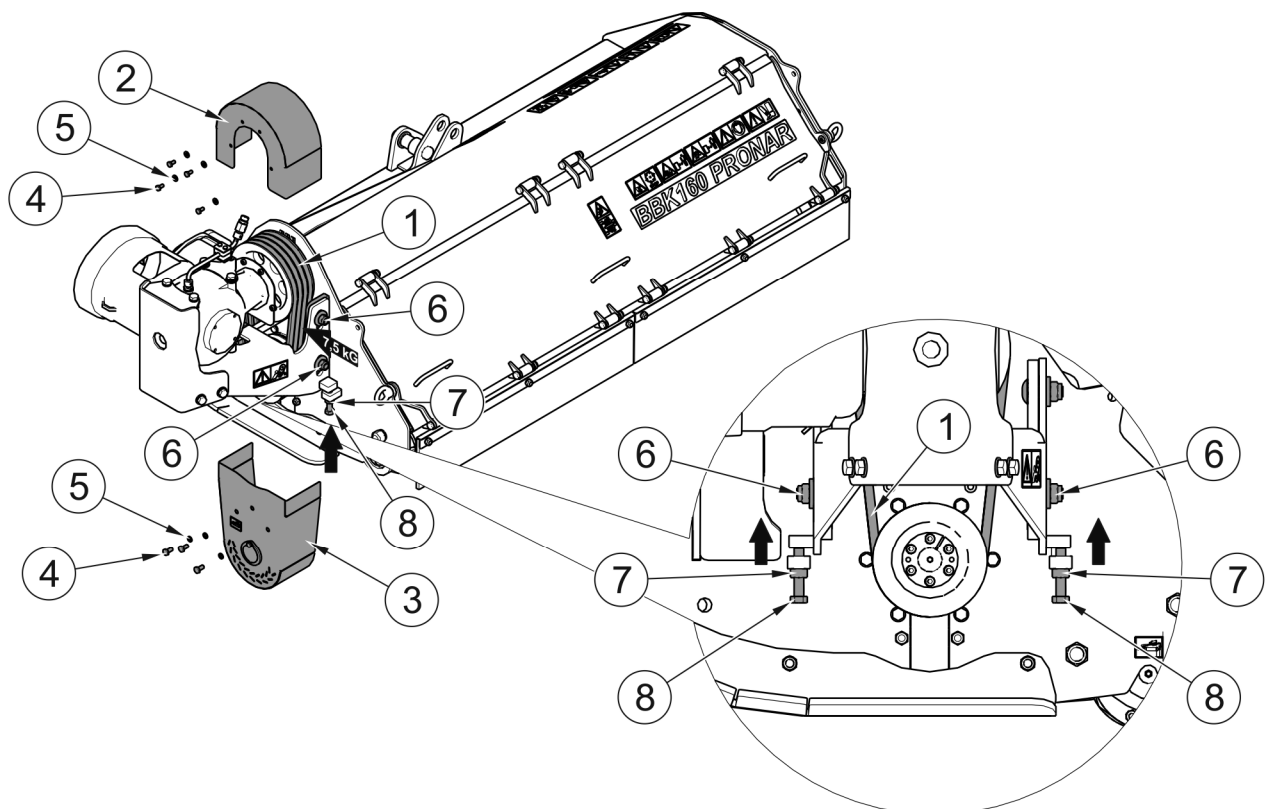
**ATTENTION!**

Check the technical condition of blades and then mounting on each occasion after driving over obstacle e.g. stone, piece of wood, metal etc.

## 5.3 DRIVE SYSTEM MAINTENANCE

Drive system maintenance involves periodic inspection, adjustment and possible replacement of vee-belts and change of oil in intersecting axis gear.

Inspection of vee-belts (1) (FIGURE 5.4) involves checking of the belt tension. Deflection of vee-belts measured between transmission's pulleys after application of 7,5 kG force should not exceed 9 mm (BBK160) and 8 mm (BBK180, BBK200).



**FIG. 5.4** Checking and adjusting tension of vee-belts

(1)- vee-belts; (2)- vee-belt shield I; (3)- vee-belt shield II; (4)- bolt; (5)- washer; (6)- nut; (7)- securing nut; (8)- adjustment bolt

In order to inspect:

- remove vee-belt shields (2, 3) by unscrewing bolts (4),
- check tension of vee-belts (1),
- loosen nuts (6) and securing nuts (7) if you want to adjust tension of vee-belts,
- set required tension of vee-belts by means of adjustment bolts (8),
- tighten securing nuts (7) and nuts (6) of the transmission base,

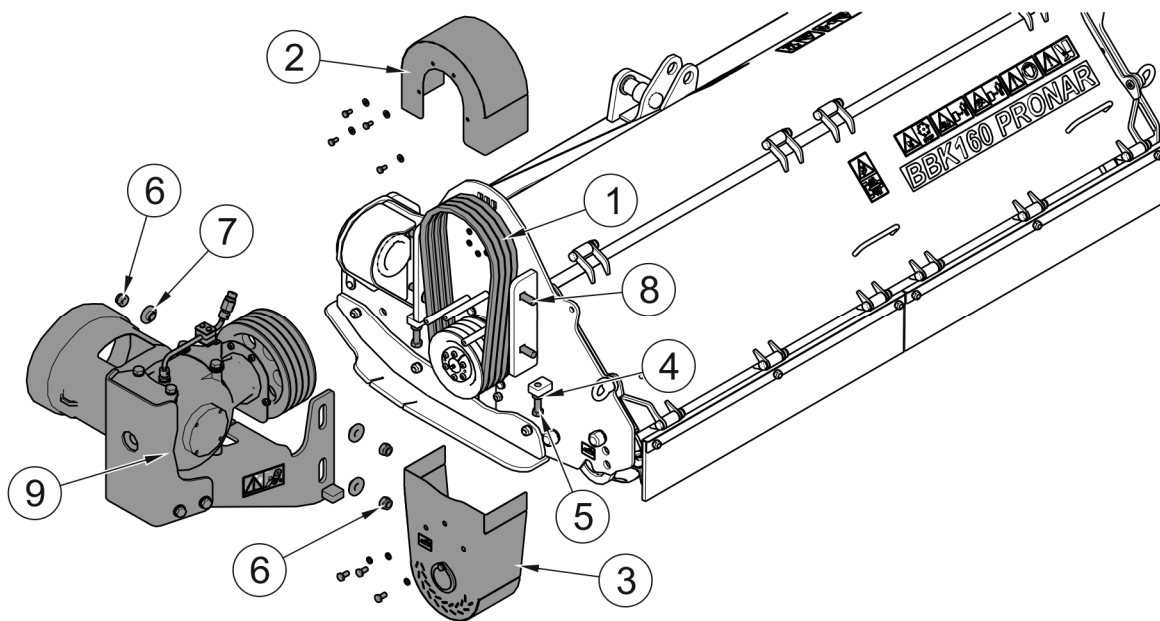
- install vee-belt shields (2, 3) and tighten bolts (4).

If one of the belts is damaged the complete belt set should be changed.

To replace the vee-belts (FIGURE 5.5):

- remove vee-belt shields (2, 3),
- loosen nuts (6) and securing nuts (4),
- unscrew bolts (5) so that the complete transmission (9) is located in the lowest position,
- remove vee-belts and replace them with new ones,
- adjust vee-belt tension,
- tighten securing nuts (4) and nuts (6) of the transmission base,
- install vee-belt shields (2, 3) and tighten bolts.

During replacement of vee-belts (1), the complete transmission (9) may be disassembled by undoing nuts (6) and removing bolts (8).



**FIG. 5.5 Replacement of vee-belts**

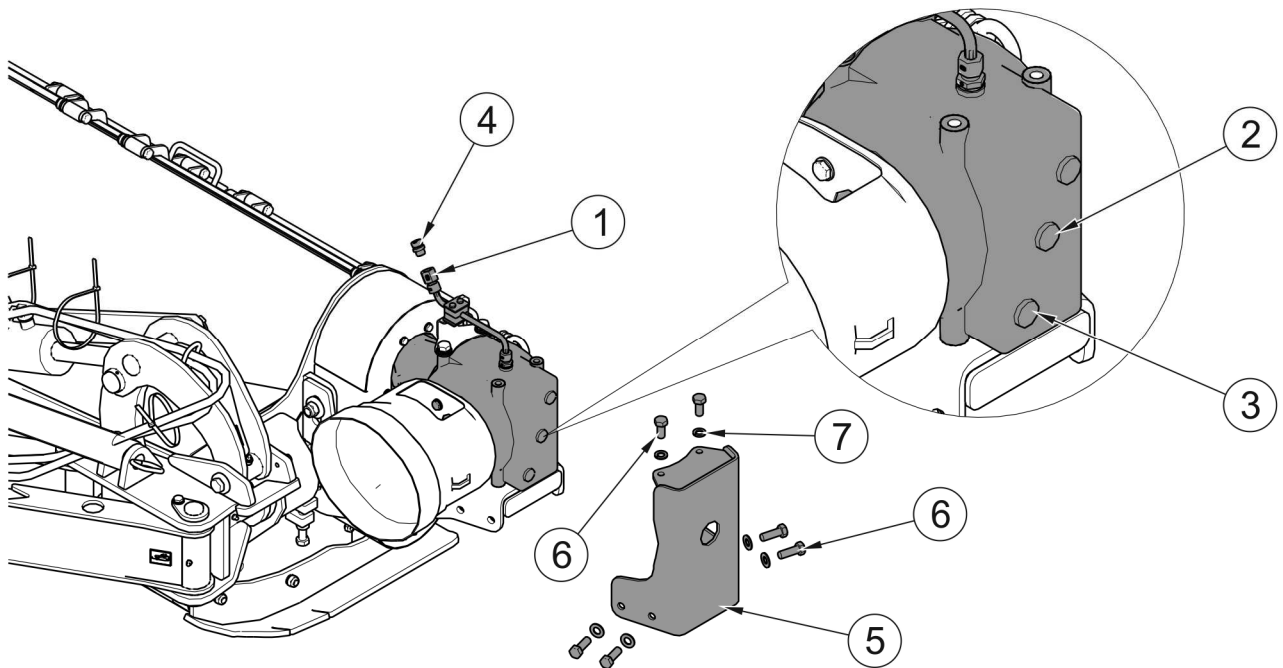
(1)- vee-belts; (2)- vee-belt shield I; (3)- vee-belt shield II; (4)- securing nut; (5)- adjustment bolt; (6)- nut; (7)- retaining ring; (8)- bolt; (9)- complete transmission with base and pulley

**DANGER**

Do NOT perform service or repair work under raised and unsupported machine.



Check oil level in intersecting axis gear daily.



**FIG. 5.6** Checking and change of oil in intersecting axis gear

(1)- oil filler; (2)- inspection plug; (3)- drain plug; (4)- air vent of intersecting axis gear;  
 (5)- shield; (6)- bolt; (7)- washer

To check the oil level in intersecting axis gear:

- set mower level horizontally,
- unscrew inspection plug (2) (FIGURE 5.6),
- oil level should reach the lower edge of the inspection plug opening (2),
- if necessary, supplement oil through inlet opening (1) to the required level.

**DANGER**

When checking oil level and changing oil use the appropriate personal protection equipment i.e. protective clothing, footwear, gloves eye protection. Avoid contact of skin with oil.



Oil in intersecting axis gear must be changed after the first 50 hours of work. The next oil change should be made after 500 hours of work or once a year, whichever occurs first.

To change oil in intersecting axis gear:

- set mower on a hard and level surface
- unscrew air vent of intersecting axis gear (4) and inspection plug (2),
- unscrew drain plug (3) and drain oil to previously prepared basin,
- if oil Manufacturer recommends flushing transmission, that operation should be performed according to the guidelines of the oil Manufacturer (guidelines may be detailed on packaging),
- tighten drain plug (3),
- add oil until oil flows out of inspection opening (2),
- tighten air vent of intersecting axis gear (4) and inspection plug (2).

Used oil should be taken to the appropriate facility dealing with the re-use of this type of waste.

To lubricate intersecting axis gear use gear oil SAE 80W90 to quantity of 1 litre.

If a leak is noticed, carefully inspect seals and check oil level. Transmission operation with insufficient oil may cause permanent damage of the mechanism.

Repair of transmission during warranty period may only be performed at authorised mechanical workshops.

## 5.4 HYDRAULIC SYSTEM OPERATION



### **DANGER**

Before commencing whatever work on hydraulic system reduce the pressure in the system.



### **DANGER**

During work on hydraulic systems use the appropriate personal protection equipment i.e. protective clothing, footwear, gloves and eye protection. Avoid contact of skin with oil.

Always adhere to the principle that the oil in the mower hydraulic system and in the tractor hydraulic system are of the same type. Application of different types of oil is not permitted. In a new mower, the hydraulic system is filled with 2.0 L of HL32 hydraulic oil.



### **ATTENTION!**

The condition of hydraulic system should be inspected regularly while using the machine.

The hydraulic system should be completely tight sealed. Inspect the seals when hydraulic cylinders are completely extended. In the event of confirmation of oil on hydraulic cylinder bodies ascertain origin of leak. Minimum leaks are permissible with symptoms of "sweating", however in the event of noticing leaks in the form of "droplets" stop using the machine until faults are remedied.

In the event of confirmation of an oil leak on hydraulic conduit connections, tighten connections, and if this does not remedy faults then change line or connection elements. Change of sub-assemblies is equally required in each instance of mechanical damage.



**Flexible hydraulic conduits should be replaced after 4 years of use.**

**TIP**

**Bleeding air from the mower hydraulic system is not required.**

**TAB. 5.1 HL32 hydraulic oil characteristics**

<b>ITEM</b>	<b>NAME</b>	<b>VALUE</b>
1	ISO 3448VG viscosity classification	32
2	Kinematic viscosity at 40°C	28.8 ÷ 35.2 mm <sup>2</sup> /s
3	ISO 6743/99 quality classification	HL
4	DIN 51502 quality classification	HL
5	Flash-point	above 210°C

Because of its composition the oil applied is not classified as a dangerous substance, however long-term action on the skin or eyes may cause irritation. In the event of contact of oil with skin wash the place of contact with water and soap. Do NOT apply organic solvents (petrol, kerosene). Contaminated clothing should be changed to prevent access of oil to skin. In the event of contact of oil with eye, rinse with large quantity of water and in the event of the occurrence of irritation consult a doctor. Hydraulic oil in normal conditions is not harmful to the respiratory tract. A hazard only occurs when oil is strongly atomised (oil vapour), or in the case of fire during which toxic compounds may be released. Oil fires should be quenched with the use of carbon dioxide (CO<sub>2</sub>), foam or extinguisher steam. Do NOT use water for fire extinguishing.

Spilt oil should be immediately collected and placed in marked tight container. Used oil should be taken to the appropriate facility dealing with the re-use of this type of waste.



## 5.5 STORAGE

After finishing work, mower should be thoroughly cleaned and washed with water jet. While washing do not direct a strong water or steam jet at information and warning decals, bearings or hydraulic lines. Nozzle of pressure or steam washer should be kept at a distance of not less than 30 cm from cleaned surface.

After cleaning, inspect the whole machine, inspect technical condition of individual elements. Used or damaged elements should be repaired or replaced.

In the event of damage to the paint coat, clean rust and dust from damaged area, degrease and then paint with undercoat and after it is dry paint with surface coat paint retaining colour uniformity and even thickness of protective coating. Until the time of touch-up painting, the damaged place may be covered with a thin layer of grease or anticorrosion preparation. Mower should be kept in closed or roofed building.

If the mower shall not be used for a long period of time, protect it against adverse weather conditions. Lubricate mower according to the instructions provided. In the event of prolonged work stoppage, it is essential to lubricate all elements regardless of the period of the last lubrication process. Additionally, before the winter period, apply grease to hitching system pins.

## 5.6 LUBRICATION

Machine lubrication should be performed with the aid of a manually or foot operated grease gun, filled with generally available permanent grease. Before commencing lubrication insofar as is possible remove old grease and other contamination. Remove and wipe off excess oil or grease



**When using the machine the user is obliged to observe lubrication instructions according to attached schedule. Excess lubrication substance causes depositing additional contaminants in places requiring lubrication, therefore it is essential to keep individual machine elements clean.**

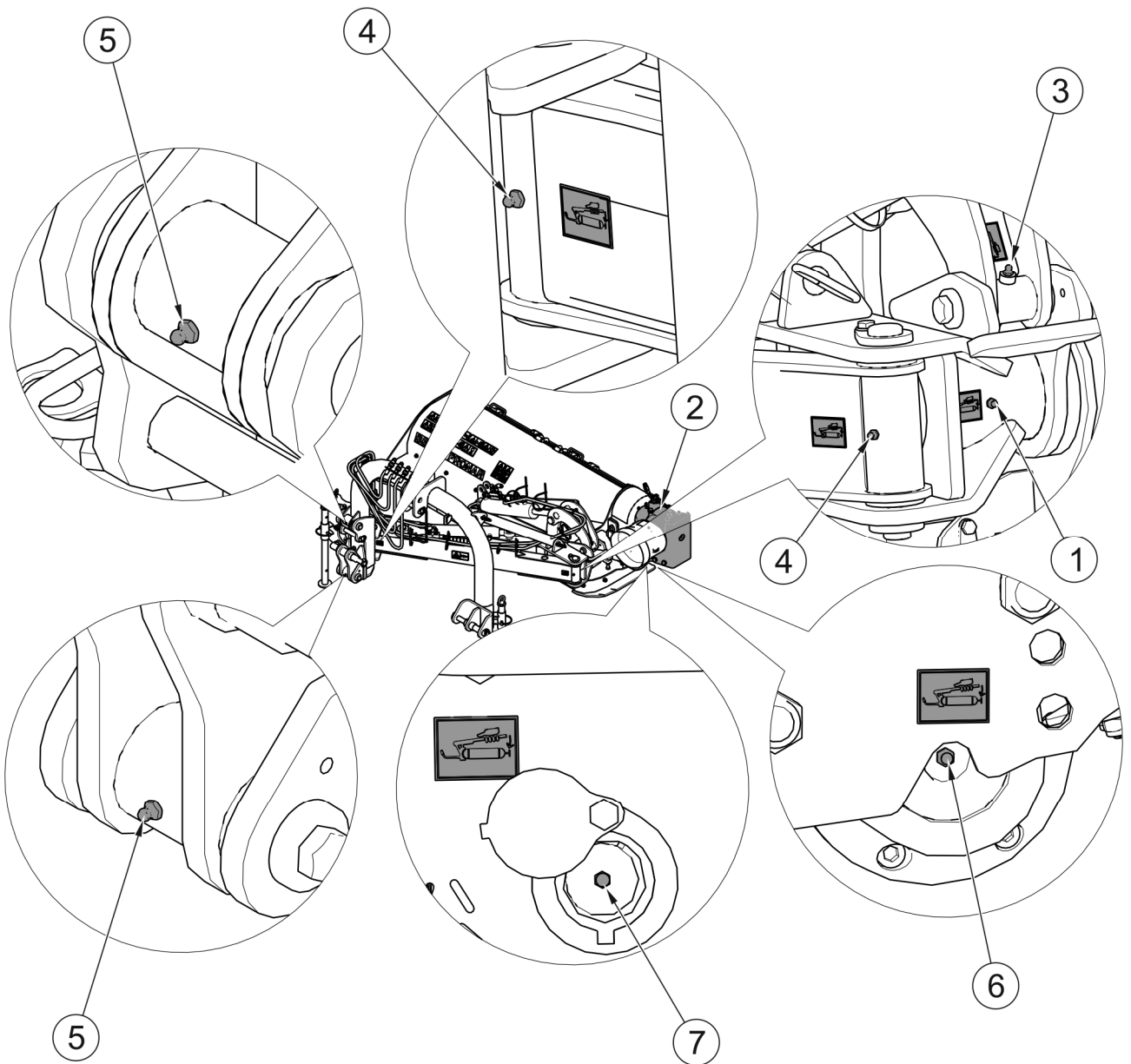
For detailed instructions on how to change oil in intersecting axis gears please refer to section 5.3 *DRIVE SYSTEM MAINTENANCE*. Lubrication points shown in FIGURE 5.7 and 5.8 are described in Table „5.2 LUBRICATION POINTS AND LUBRICATION FREQUENCY”.

**TAB. 5.2 LUBRICATION POINTS AND LUBRICATION FREQUENCY**

<b>IT E M</b>	<b>NAME</b>	<b>NUMBER OF LUBRICATIO N POINTS</b>	<b>TYPE OF GREASE</b>	<b>LUBRICATION FREQUENCY</b>
1	Rotary mount carrying shaft	1	grease	20 hours
2	Intersecting axis gear	1	oil	500 hours
3	Rocker arm pin	1	grease	20 hours
4	Linkage link pin	4	grease	20 hours
5	Linkage pin	2	grease	20 hours
6	Tracking shaft bearing	2	grease	daily
7	Flail shaft bearing	2	grease	daily
8	Link pin	2	grease	20 hours
9	PTO shaft *	*	*	*

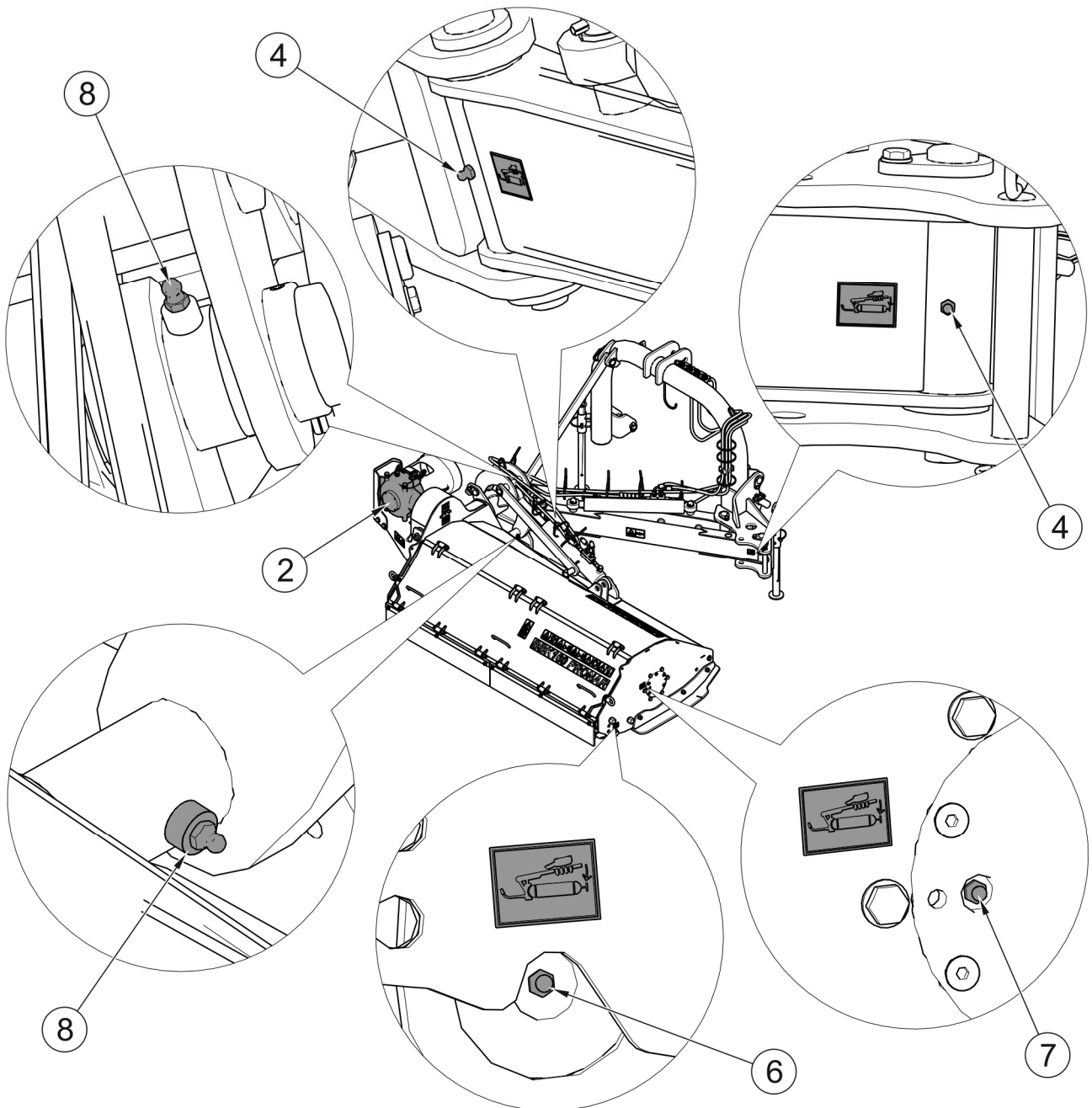
*Marking description in Item column (TAB. 5.2) conforms with numbering shown on (FIG. 5.7 and 5.8)*

*\* For detailed information on maintenance please refer to maintenance instructions attached to the shaft.*



**FIG. 5.7** Lubrication points (view A)

*Lubrication points described in table 5.2*



**FIG. 5.8      Lubrication points (view B)**

*Lubrication points described in table 5.2*

## 5.7 TIGHTENING TORQUE FOR NUT AND BOLT CONNECTIONS

Unless other tightening parameters are given, during maintenance repair work apply appropriate torque to tightening nut and bolt connections. Recommended torque values apply to non-greased steel bolts.



### ATTENTION!

Should it be necessary to change individual parts, use only original parts or those indicated by the Manufacturer. Non-adherence to these requirements may put the user and other people's health and life at risk, and also damage the machine.

TAB. 5.3 TIGHTENING TORQUE FOR NUT AND BOLT CONNECTIONS

THREAD DIAMETER [mm]	5.8	8.8	10.9
	TIGHTENING TORQUE [Nm]		
M6	8	10	15
M8	18	25	36
M10	37	49	72
M12	64	85	125
M14	100	135	200
M16	160	210	310
M20	300	425	610
M24	530	730	1 050
M27	820	1,150	1,650
M30	1050	1 450	2 100
M32	1050	1 450	2 100

## 5.8 TROUBLESHOOTING

TAB. 5.4 TROUBLESHOOTING

TYPE OF FAULT	CAUSE	REMEDY
It is impossible to set lateral tilt or inclination of the mower's cutting unit by means of hydraulic cylinders	Hydraulic cylinder locks are installed	Disconnect hydraulic cylinder locks, place them in appropriate place and secure (FIGURE 4.5)
	Incorrectly connected or damaged quick coupler	Check quick coupler and manner of connection
	Unreliable tractor hydraulic system	Check condition of tractor hydraulic system
Excessive vibration during work	Damaged or missing flail blade	Check flail blades, if necessary replace
	Damaged PTO shaft	Check shaft, if necessary replace
	Damaged bearings of the flail shaft	Repair at authorised service point
Excessive heating of intersecting axis gear	Incorrect oil level	Check oil level
	Damaged bearing	Repair at authorised service point
Mower drive stops during cutting	Belt slip on belt drive transmission	Switch off the mower, remove collected grass or foreign body from cutting unit and check condition and tension of belts
	Damaged intersecting axis gear	Repair at authorised service point

# NOTES

A series of horizontal dotted lines for writing notes.

